

4CARL

4 Flutes 45° Helix Corner Radius Long End Mills

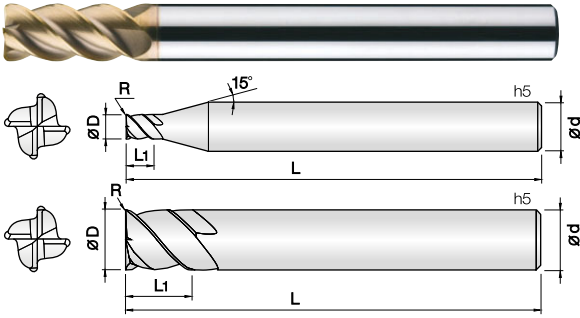

- Endmills for pre-hardened and hardened steel (HRC50~62)
- Good wear resistance by Si-based PVD coating.
- High precise edge tolerance.
- Designed for minimizing edge chipping by corner R shape.
- 45° degree helix design for high speed, feed condition.
- Outstanding performance at high speed machining by ultra fine (0.2 μm) WC grade.

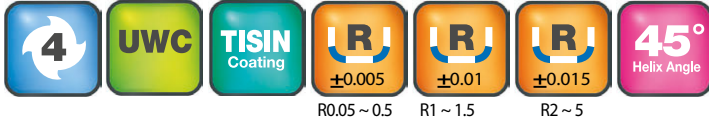

D Size	D Tolerance
ø1 ~ 4	+0 ~ -0.01 mm
ø6 ~ 12	-0.005 ~ -0.015 mm
ø16 ~ 20	-0.01 ~ -0.02 mm

Slotting																
Material	Alloy Steel								Hardened Steels							
Hardness	200 ~ 250HB				25 ~ 35HRC				35 ~ 45HRC				45 ~ 62HRC			
Outside Diameter	RPM	FEED	Ap Axial Depth	Ae Radial Depth	RPM	FEED	Ap Axial Depth	Ae Radial Depth	RPM	FEED	Ap Axial Depth	Ae Radial Depth	RPM	FEED	Ap Axial Depth	Ae Radial Depth
∅ 1	19,250	150	0.50	1	19,250	150	0.50	1	17,280	122	0.50	1	15,552	98	0.2	0.8
∅ 1.5	12,845	230	0.75	2	12,800	220	0.75	2	11,520	178	0.75	2	10,368	142	0.3	1.2
∅ 2	9,600	345	1.00	2	9,500	330	1.00	2	8,550	267	1.00	2	7,695	212	0.4	1.6
∅ 3	6,400	490	1.50	3	6,400	440	1.50	3	5,800	360	1.50	3	5,300	240	0.6	2.4
∅ 4	4,800	550	2.00	4	4,800	500	2.00	4	4,400	410	2.00	4	4,000	280	0.8	3.2
∅ 5	3,850	600	2.50	5	3,800	550	2.50	5	3,420	446	2.50	5	3,078	356	1.0	4.0
∅ 6	3,200	610	3.00	6	3,200	550	3.00	6	2,900	450	3.00	6	2,700	310	1.2	4.8
∅ 8	2,400	650	4.00	8	2,400	590	4.00	8	2,200	480	4.00	8	2,000	330	1.6	6.4
∅ 10	1,900	580	5.00	10	1,900	520	5.00	10	1,800	440	5.00	10	1,600	290	2.0	8.0
∅ 12	1,600	540	6.00	12	1,600	480	6.00	12	1,500	400	6.00	12	1,300	260	2.4	9.6
∅ 16	1,200	520	8.00	16	1,200	510	8.00	16	1,080	413	8.00	16	972	328	3.2	12.8
∅ 20	960	510	10.00	20	950	500	10.00	20	855	405	10.00	20	770	324	4.0	1.6

Depth of Cut

~ 45HRC

45HRC ~

0.2D

Inclined Cutting

Side Cutting																
Material	Alloy Steel								Hardened Steels							
Hardness	200 ~ 250HB				25 ~ 35HRC				35 ~ 45HRC				45 ~ 62HRC			
Outside Diameter	RPM	FEED	Ap Axial Depth	Ae Radial Depth	RPM	FEED	Ap Axial Depth	Ae Radial Depth	RPM	FEED	Ap Axial Depth	Ae Radial Depth	RPM	FEED	Ap Axial Depth	Ae Radial Depth
∅ 1	28,790	115	1	0.1	25,911	104	1	0.1	22,024	88	0.5	0.03	17,619	70	0.5	0.03
∅ 1.5	19,200	403	2	0.2	17,280	363	2	0.2	14,688	308	0.8	0.045	11,750	247	0.8	0.045
∅ 2	14,400	690	2	0.2	12,960	621	2	0.2	11,016	528	1.0	0.06	8,813	422	1.0	0.06
∅ 3	9,600	860	3	0.3	9,600	770	3	0.3	8,500	610	1.5	0.09	7,400	460	1.5	0.09
∅ 4	7,200	920	4	0.4	7,200	830	4	0.4	6,400	660	2.0	0.12	5,600	500	2.0	0.12
∅ 5	5,750	960	5	0.5	5,175	864	5	0.5	4,399	734	2.5	0.15	3,519	588	2.5	0.15
∅ 6	4,800	1,080	6	0.6	4,800	970	6	0.6	5,100	720	3.0	0.18	3,700	580	3.0	0.18
∅ 8	3,600	1,150	8	0.8	3,600	1,040	8	0.8	4,200	750	4.0	0.24	2,800	630	4.0	0.24
∅ 10	2,900	1,070	10	1.0	2,900	960	10	1.0	2,500	740	5.0	0.3	2,200	570	5.0	0.3
∅ 12	2,400	1,000	12	1.2	2,400	900	12	1.2	2,100	700	6.0	0.36	1,900	550	6.0	0.36
∅ 16	1,800	1,000	16	1.6	1,620	900	16	1.6	1,377	765	8.0	0.48	1,102	612	8.0	0.48
∅ 20	1,440	930	20	2.0	1,296	837	20	2.0	1,102	711	10.0	0.6	881	569	10.0	0.6

Depth of Cut

~ 35HRC

35HRC ~

0.03D

- The parameters on the table is based on 4flutes. For using 6flutes, use the same RPM and raise up the feed up to 30% in stable milling condition.
- If the effective length is long, reduce the RPM and feed maximum 30%.
- For side milling, refer to the corner radius value.
- For curved milling, set up the lower value of the pitch than the corner radius value of tool diameter.
- For curved milling, raise up the feed up to 30% in stable milling condition.
- Use this table for your reference. Adjust the parameters depending on your machining geometry, machining purpose and CNC.
- If the table over the maximum RPM and feed of your machine, or found red heat on the material, adjust RPM and feed in the same proportion.
- Use suitable cutting oil for material and machining geometry.