



2024-2025

NON-ROTATING METALCUTTING TOOLS



TaeguTec
Member IMC Group

Contents

<h2>Turning</h2>		<ul style="list-style-type: none"> Contents A 2 Toolholders A 43 Inserts A 223 	<h1>A</h1>	<p>Turning</p>
<h2>Parting & Grooving</h2>		<ul style="list-style-type: none"> Contents B 2 Toolholders B 33 Inserts and Solid Bars B 125 	<h1>B</h1>	<p>Parting & Grooving</p>
<h2>Thread Making</h2>		<ul style="list-style-type: none"> Contents C 2 Thread Turning C 9 	<h1>C</h1>	<p>Thread Making</p>
<h2>Holemaking</h2>		<ul style="list-style-type: none"> Contents D 2 Drilling Tools D 17 Reaming Tools D 111 	<h1>D</h1>	<p>Holemaking</p>
<h2>Materials & Grades</h2>		<ul style="list-style-type: none"> Grade Comparison Table I 2 Chip Braker Comparison Table I 10 Hardness Conversion Table I 14 Material Conversion Table I 16 	<h1>I</h1>	<p>Materials & Grades</p>
<h2>Index</h2>				<p>Index</p>

How to use the catalogue page

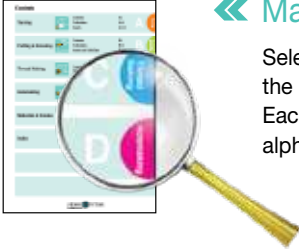

« Main Contents

Select an application line from the main Table of Contents. Each line is color coded in alphabetical order.



Tool Selection Guide »

Choose the required machining solutions and tools from tool selection guide.

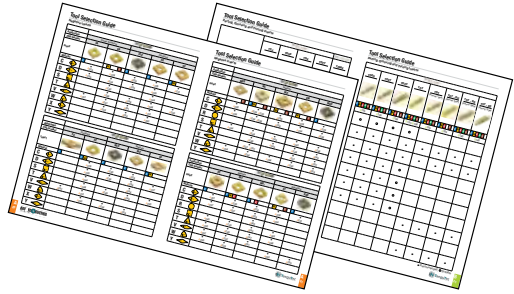

Products Page »

Obtain detailed information of products such as dimensions, grades and related parts etc. Holder and insert pages are organized separately.

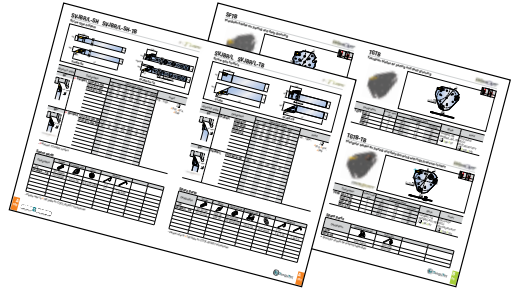

Alphabetical Index »

All tools are listed in the alphabetical index at the end of the catalogue.

ARC

Should you require more information and data from TaeguTec, please contact the nearest TaeguTec Global Service Center or visit our website. www.taegutec.com

TURNING



TURNING



contents

Tool Selection Guide

External Holders	A4
Internal Boring Bars	A15
Negative Inserts	A20
Positive Inserts	A24
Grades	A26
Chip Breakers	A31
External Toolholders	
Designation System for External Toolholders	A44
External Toolholders	A47
TURN-SFEED Holders	A77
MULTI-L-TURN Holders	A92
WIN-TURN Holders	A107
POS-S-TURN Holders	A110
TOP-RAIL Holders	A134
COOL-BURST Accessories	A135
WIN-SWISS Holders	A137
C-ADAPTER	A144

Guide to Icons



➤ Toolholder Page



➤ Insert Page



Boring Bars













Designation System for Boring Bars	A164
Boring Bars	A165
POS-S-TURN	A199
HUSH-BORE	A203
HUSH-MODU	A222

Inserts

Designation System	A224
Negative Inserts	A226
WIN-TURN Inserts	A256
POS-S-TURN Inserts	A257
Positive Inserts	A259
TURN-SFEED Inserts	A270
Pipe Skiving Inserts	A286
TOP-RAIL Inserts	A288
Ceramic Inserts	A289
CBN/PCD Inserts	A303
Recommended Cutting Conditions	A316

Tool Selection Guide

Holders







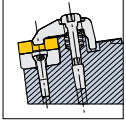























Insert type		General turning (For red color, refer to Rhino catalog)							
		C	D	R	S	T	V	W	E
									
Negative insert		07, 09, 12-25	08, 13, 11, 15	09-25	09, 12-31	13, 16-33	13, 16	04, 06, 08	13
Positive insert		03-12	07, 11	06-32	09-19	06 - 27	08-22	06	
	Ext. A7	●	●	●	●	●		●	
	Int. A18, A19	●	●		●	●			
	Ext. A8, A10, A11, A15	●	●	●	●	●	●		
	Int. A16, A18, A19	●	●		●	●	●	●	
	Ext. A12				●				
	Int. A17								
	Ext. A12		●			●	●	●	
	Int. A17							●	
	Ext. A6, A14, A15	●	●	●	●	●	●	●	●
	Int. A18, A19	●	●		●		●	●	
	Ext. A13			●	●	●			
	Int. A17				●	●			
	Ext. A12					●			
	Int. A18					●			
	Ext. A13	●	●		●				
	Int. A18	●							

Tool Selection Guide

External holders



T-Holder







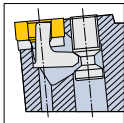

















 	 TCBNR/L A100	 TCKNR/L A100	 TCLNR/L A101	 TXJNR/L A110 TXJNR/L-TB A111
	 TDJNR/L A102	 TDNNR/L A102		
	 TTGNR/L A106	 TTJNR/L A106	 TTQNR/L(-TB) A107	
	 TSDNN A104	 TSKNR/L A105	 TSSNR/L A105	
 	 TVJNR/L A108	 TVQNR/L A108		
 	 TZQNR/L A112	 TZQNR/L-TB A112	 TZXNN A113	 TZXNN-TB A113
	 TWLNR/L A109			 THSNR/L A103

Tool Selection Guide

External holders



P Lever lock

	 PCBNR/L A58	 PCKNR/L A58	 PCLNR/L A59	 PCLNR/L-TB A59
	 PDJNR/L A60	 PDJNR/L-TB A60	 PDNNR/L A61	
	 PTFNR/L A67	 PTGNR/L A68	 PTTNR/L A68	
	 PSBNR/L A65	 PSDNN A65	 PSKNR/L A66	 PSSNR/L A66
	 PWLNR/L-TB A69			
	 PRDCN A62	 PRGCR/L A63	 PRGNR/L A64	

Tool Selection Guide

External holders

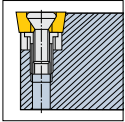

S Screw clamp

	SCACR/L-SH A70	SCACR/L-SH-TB A70	SCLCR/L-SH A71	SCLCR/L-SH-TB A71
	SCLCR/L A72			
	SDJCR/L-SH A73	SDJCR/L-SH-TB A73	SDJCR/L A74	SDJNR/L A74
	SDNCN-SH A75	SDNCN-SH-TB A75	SDNCN A76	SDQNR/L A76
	STFCR/L A81	STGCR/L-SH A82	STGPR-SH A82	STGCR/L-SH-TB A82
	STGCR/L A83			
	SFXCN A77			

Tool Selection Guide

External holders

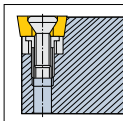

S Screw clamp

	SVJBR/L-SH A84	SVJBR/L-SH-TB A84	SVJBR/L A85	SVJBR/L-TB A85
	SVJCR/L-SH A86	SVJCR/L-SH-TB A86	SVJCR/L A87	SVJNR/L A87
	SVPBR/L A88	SVVBN-SH A89	SVVBN-SH-TB A89	SVVBN A90
	SVVCN A90	LVJBR/L A92	LVJBR-SH A92	LVQBR/L A93
	LVVBN A93			
	SSDCN A80	SSSCR/L A80		
	SRDCN A78	SRGCR/L A79	SRGCR/L-TB A79	

Tool Selection Guide

External holders

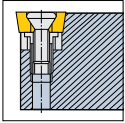

TM... Miniature tool holder (Screw clamp)

TMB Back turning holders				TMB-SVXCR A91 TMB-SVXCR-TB A91
TMS Sleeve holders				TMS-SDUCL A95 TMS-SDUCR/L-TB A95
				TMS-SVUBL A96 TMS-SVUBR/L-TB A96 TMS-SVUCL A96
TMY Y-axis holders				TMY-SDJCR A97 TMY-SDJCR-TB A97
				TMY-SVJBR A98 TMY-SVJBR-TB A98
TMZ Shift holders				
		TMZ-SVLBR A99		

Tool Selection Guide

External holders

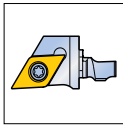

QE Modular head (Screw clamp)





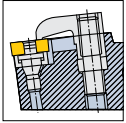

QE1 External turning modular head					
		QE1 SDJCR A137	QE1 SDJCR-TB A137		
QE1 External turning modular head					
		QE1 SVJBR A138	QE1 SVJBR-TB A138	QE1 SVJCR A139	QE1 SVJCR-TB A139
QE1B Back turning modular head					
		QE1B SVXCR A140	QE1B SVXCR-TB A140		
QE1Y Y-axis modular head					
		QE1Y SDJCR A141	QE1Y SDJCR-TB A141		

Tool Selection Guide

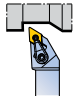
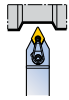
External holders



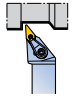
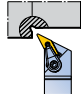
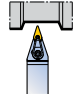

M Multi lock

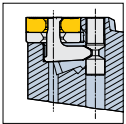
	 MDJNR/L A52	 MDNNA A52	 MDQNR/L A53
	 MTJNR/L A54		
	 MVJNR/L A55	 MVQNR/L A55	 MNVNA A56



H Hook lever holder

	 HSBNR/L A51	 HSDNA A51
---	---	---

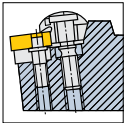

W Wedge clamp

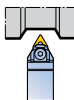
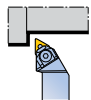
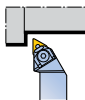





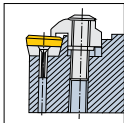

	 WTENNA A114	 WTGNR/L A114	 WTJNR/L A115
---	--	---	---

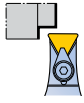
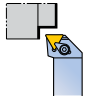
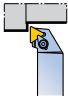
Tool Selection Guide

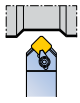
External holders

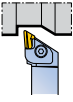

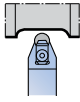

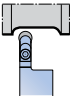
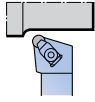

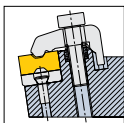
C Top clamp

	 CTCPN A49	 CTFPR/L A49	 CTGPR/L A50
	 CSDPN A48		
	 CKJNR/L A47	 CKNNR/L A47	
	 CRDCN-120 A116 CRDCN-140 A116	 CRDCN-T A117	 CRDCR/L-T A117  CRGCR/L-120 A118 CRGCR/L-140 A118

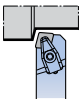
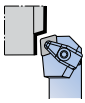
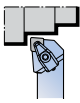

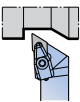
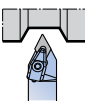
T-CH CH dimple holder

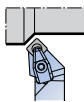

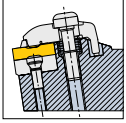

	 TCBNR/L-CH A120	 TCKNR/L-CH A120	 TCLNR/L-CH A121
	 TDJNR/L-CH A122	 TDNNN-CH A122	  TSSNR/L-CH A123

Tool Selection Guide

External holders







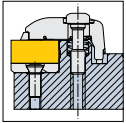











T-DA DA dimple holder

	 TCLNR/L-DA A124		 TSDNN-DA A125	 TSKNR/L-DA A125
---	--	---	--	--



T-F Flat T-Holder







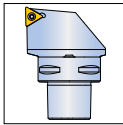





















	 TCLNR/L-F A126	 CCLNR/L-F A119		
	 TDJNR/L-F A127			
	 TSDNN-F A130	 TSKNR/L-F A130	 TSRNR/L-F A131	 TSSNR/L-F A131
	 TTJNR/L-F A132			
	 TRDNN-F A129	 TRGNR/L-F A129		 TEGNR/L-F A128

Tool Selection Guide

External and internal C-adapter



C C-Adapter

	 C...TCLNR/L A146	 C...SCLCR/L A151	 C...SCLCR/L A154	
	 C...TDJNR/L A146	 C...SDJCR/L A151	 C...SDUCR/L A154	
	 C...TTGNR/L A148  C...TTJNR/L A148	 C...STGCR/L A152  C...STJCR/L A152	 C...STFCR/L A155	
	 C...TSDNN A147	 C...TSSNR/L A147		
	 C...TVJNR/L A148	 C...SVJBR/L A153	 C...SVBN A153	 C...SVQBR/L A155
	 C...TZQNR/L-TB A150		 C...TWLNR/L A149	
	 C...SRDCN A152			

Tool Selection Guide

Internal boring bars

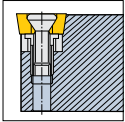

S Screw clamp







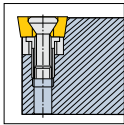



	S-SCLCR/L A174 C-SCLCR/L A175 E-SCLCR/L A175	S-SCLPR/L A176 A-SCLPR/L A176	E-SCLPR/L A177	S-SDQCR/L A178
	A-SDQNR/L A178	A-SDLNR/L A177	S-SDUCR/L A179	A-SDUNR/L A179
		S-SDZCR/L A180		
	S-STFCR/L A182	S-STFPR/L A183 A-STFPR/L A183	C-STFPR/L A184 E-STFPR/L A184	S-STUBR/L A185 C-STUBR/L A185
		C-STZBR/L A186		
	S-SVJBR/L A187 S-SVJCR/L A187	S-SVJPR/L A188	A-SVLNR/L A188	S-SVPBR/L A189 S-SVPCR/L A189
	A-SVPCR/L A189	S-SVQBR/L A191 S-SVQCR/L A191	S-SVUBR/L A192	S-SVQCR/L A191 S-SVUCR/L A192

Tool Selection Guide

Internal boring bars







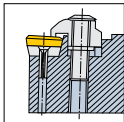

S Screw clamp

	 S-SSKCR/L A181		 A-SXUNR/L A190
	 A-SVLNR/L A188	 A-SVPCR/L A190	  S-SWUBR/L A193  C-SWUBR/L A193



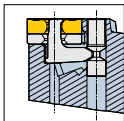

C Top clamp

	 S-CSKPR/L A166		 S-CTFCR/L A167  S-CTFPR/L A167	  S-CKUNR/L A165
--	---	---	---	--



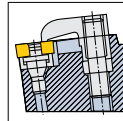

H Hook lever holder

	 A-HXUNR/L A168
--	---



M Multi lock







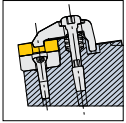



	 S-MWLNR/L A169
---	---

Tool Selection Guide

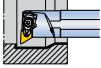
Internal boring bars





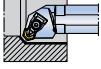

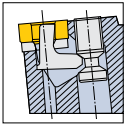



T Holder

	 A-TCLNR/L A194		 A-TXUNR/L A199		 A-TDUNR/L A195
	 A-TSKNR/L A197		 S-TWLNLR/L A198 A-TWLNLR/L A198		 A-THSNR/L A196



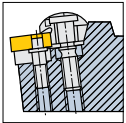

P Lever lock

	 S-PCLNR/L A170		 S-PSKNR/L A172	
	 S-PDUNR/L A171	 S-PDZNR/L A171		 S-PTFNR/L A173



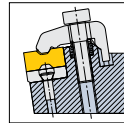

W Wedge clamp

	 S-WTFNR/L A200
---	---



T-CH CH dimple holder







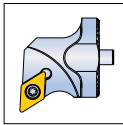









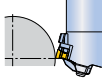



	 S-TCLNR/L-CH A201
---	--

Tool Selection Guide

Internal boring bars

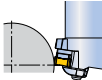























QH Modular head

	 QH-SCLCR/L A208	 QH-PCLNR/L A203	 QH-TCLNR/L A205	
	 QH-SXUNR/L A212	  QH...Y-TZXNN-TB A213		
	 QH-SDUCR/L A209	 QH-SDUCR/L-VH A214	 QH-PDUNR/L A203	 QH-TDUNR/L A206
	 QH-SVUBR/L A211	 QH-SVLCR/L-VH A214	 QH-TVUNR/L A206	
	 QH...Y-TTXNN-TB A213	 QH-PTFNR/L A204	 QH-STFCR/L A210	
	 QH-TWLNRL/L A207			

Tool Selection Guide













Negative inserts













		<i>T-TURN</i>				
Application		Super finishing		Finishing		
Chip breaker		FA	EA	FLP	FG	SF
Insert						
Material		P	M S	P	P	P M
C 		● A229	● A228	● A229	● A229	● A231
D 		● A235	● A234	● A235	● A235	
S 			● A243		● A244	
T 			● A248	● A248	● A248	● A250
V 		● A251	● A251	● A251	● A251	
W 			● A253	● A254	● A253	
X 						
Y 						

		<i>T-TURN</i>				
Application		Finishing		Medium		
Chip breaker		FX	FC	MLP	MC	VF
Insert						
Material		P	P M	P	P	P M
C 			● A229	● A230	● A229	
D 			● A235	● A236	● A236	● A237
S 			● A244		● A244	
T 			● A248	● A249	● A249	● A250
V 		● A252	● A251			
W 			● A253	● A254	● A254	
X 						
Y 						

Tool Selection Guide













Negative inserts













		T-TURN				
Application	Medium					
Chip breaker	MGS	ML	MP	EM	MGP	
Insert						
Material	S	P M S	M S	M S	P	
C 	● A230	● A226 A230	● A230	● A228	● A229	
D 	● A236	● A234 A236	● A236	● A234	● A236	
R 						
S 	● A244	● A244	● A245	● A243	● A244	
T 		● A249	● A249	● A248	● A249	
V 		● A251 A252		● A251	● A252	
W 	● A254	● A254	● A254	● A253	● A254	
Y 						

		T-TURN				
Application	Medium			Roughing		
Chip breaker	PC	MT	No Notation	ET	RGP	
Insert						
Material	P	P M K	P K	M S	P	
C 	● A231	● A230	● A228	● A228	● A231	
D 	● A237	● A237	● A234	● A234		
R 			● A240			
S 	● A245	● A245	● A243	● A243		
T 	● A250	● A249	● A247	● A248		
V 	● A252	● A252	● A251			
W 	● A255	● A255		● A253	● A255	
Y 						

Tool Selection Guide



Negative inserts











		T-TURN				
Application	Roughing					
Chip breaker	RT	KT	RX	RH	EH	
Insert						
Material	P M K	K	P	P	M	
C 	• A231	• A229	• A233	• A233	• A232	
D 	• A237	• A235	• A238			
R 						
S 	• A245	• A244	• A246	• A246	• A245	
T 	• A250	• A249	• A250	• A250		
V 						
W 	• A255	• A254				
Y 						

		T-TURN				
Application	Roughing				Finishing wiper	
Chip breaker	HT	HD	HY	HZ	WS	
Insert						
Material	P	P	P	P	P M K	
C 	• A227 A232	• A227	• A227 A232	• A227 A232	• A232	
D 					• A238	
R 						
S 	• A242 A245	• A241	• A242 A246	• A242 A246		
T 						
V 						
W 					• A255	
Y 						

Tool Selection Guide













Negative inserts













	T-TURN				
Application	Medium wiper	Medium		Roughing	Finishing / Medium
Chip breaker	WT	GU	SU	KNUX	TNMV
Insert					
Material	P M K S	P K	P M S	P M	P M
C	 80° A226 A232				
D	 55° A238				
H	 120°	A239	A239		
S	 90°			A239	
T	 60°				A256
V	 35°				
W	 80° A255				
Y	 125°				

	POSTURN				
Application	Finishing / Medium				
Chip breaker	XNMV	ZNMV	ZNMV Y-BF		
Insert					
Material	P K S	P S P	S		
C	 80°				
D	 55°				
H	 120°				
K	 90°				
T	 60°				
V	 35°				
X	 70° A257				
Z	 45°	A258	A258		

Tool Selection Guide















Positive inserts













T-TURN						
Application	Super finishing		Finishing		Medium	
Chip breaker	FA		FG	FX	PC	FM
Insert						
Material	P M		P M	S P	P M	S P M
C 	• A263		• A263 A264		• A263 A264	• A263 A264
D 	• A268		• A268		• A268	• A268
R 					• A271	
S 			• A272		• A272	• A272
T 	• A276 A279		• A276 A279		• A276 A279	• A276 A279
V 	• A282		• A282	• A282	• A282 A284	• A282 A284
W 						
F 						

T-TURN						
Application	Medium		Medium wiper	Roughing		
Chip breaker	MT		MGS	WT	No Notation	RA
Insert						
Material	P M K		M S	P M K	P M K S	P
C 	• A263			• A263		
D 	• A268					
R 	• A271		• A271			• A271
S 	• A272				• A273	
T 	• A276				• A279	
V 	• A282					
W 						
F 						

Tool Selection Guide

Positive inserts

	T-TURN						TURN SPEED
Application	Roughing	Finishing				Medium	
Chip breaker	No Notation	FF	GF	GW	FGS	FCMX	
Insert							
Material	P	P M S	P M S	P M S	S	P	
C		• A261	• A260	• A260			
D		• A266 A269	• A265 A269	• A265			
R		• A271					
S							
T		• A274 A277	• A275 A277				
V		• A281 A285	• A281 A285	• A281	• A282		
W		• A286					
F						• A270	

	T-TURN					
Application	Finishing					
Chip breaker	SL	SA	SM	SH	FL	ST
Insert						
Material	P M S	P M S	P M S	P M S	M N S	P M S
C		• A261	• A262	• A262	• A261	
D		• A266	• A267	• A267	• A266	• A267
R					• A271	
S					• A272	
T		• A275			• A275	
V		• A281 A283	• A281 A283	• A283	• A283	
W						
F						

Grades

Selection guide for turning grades

For steel (**SPEED RUSH** - CVD coated)

Cutting speed

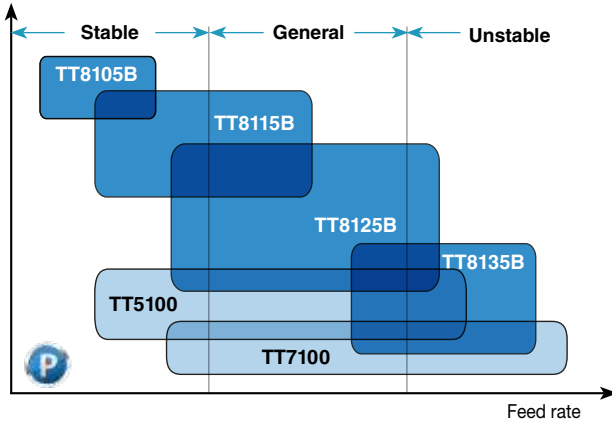

For stainless steel (CVD & PVD coated)

Cutting speed

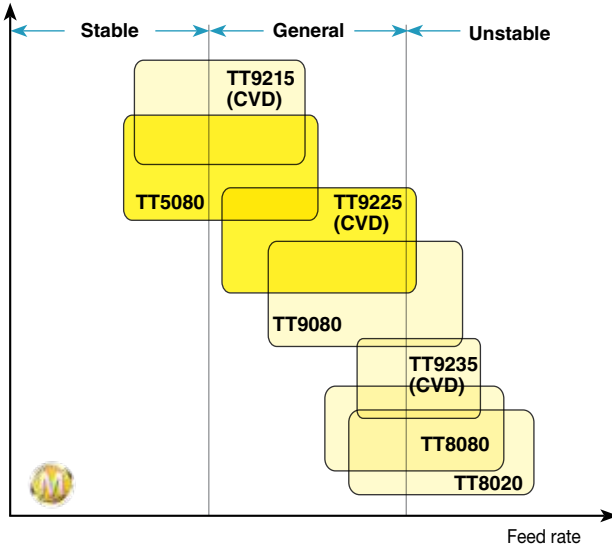

Grades

Selection guide for turning grades

For cast iron (CVD coated)

Cutting speed

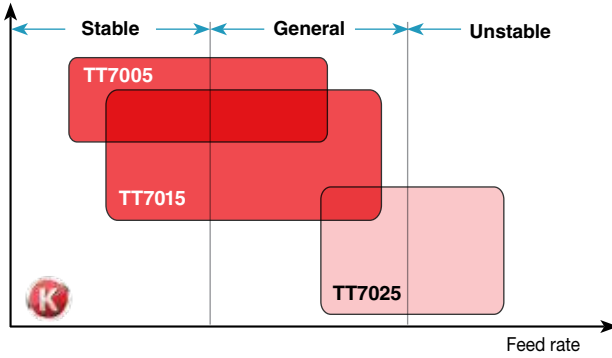

For super alloys (CVD & PVD coated)

Cutting speed

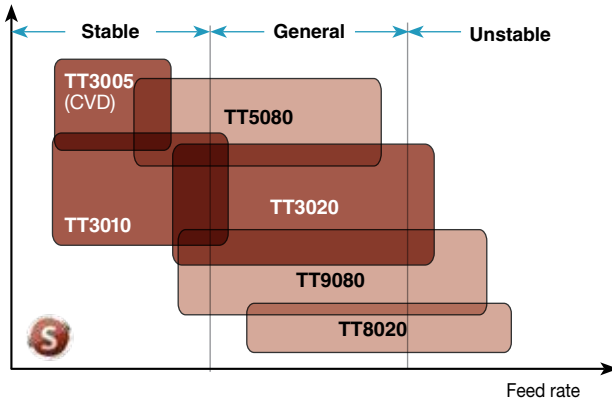

For small parts machining (PVD coated)

Cutting speed

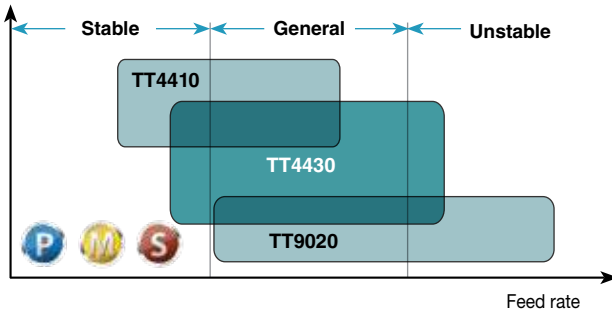

Grades

Carbide grades

Grades	ISO	Characteristics & applications
TT7005 CVD coated	K05 – K15	• High speed turning of gray cast iron in continuous conditions
TT7015 CVD coated	K10 – K25	• General turning of gray and ductile cast iron in continuous and interrupted conditions
TT7025 CVD coated	K20 – K35	• Interrupted turning of gray and ductile cast iron especially good in ductile cast iron
TT8105B CVD coated	P05 – P15	• High speed turning of steel in continuous conditions
TT8115B CVD coated	P05 – P20	• General turning of steel in high speed conditions
TT3005 CVD coated	S05 – S15	• Finish turning of heat resistant super alloys in high speed and low depth of conditions
TT9215 CVD coated	M05 – M20 S05 – S20	• High speed turning of stainless steel and heat resistant super alloys in continuous conditions
TT4410 PVD coated	M05 – M25 P05 – P25 S05 – S25	• High speed turning of small parts for stainless steel, steel and titanium alloys in continuous conditions
TT3010 PVD coated	S05 – S20	• High speed turning of heat resistant super alloys in continuous conditions
TT5080 PVD coated	M05 – M25 S05 – S25	• Wide range of turning for stainless steel and heat resistant super alloy
TT3020 PVD coated	S10 – S30	• General turning of heat resistant super alloy
TT8125B CVD coated	P15 – P30	• General turning of steel in wide range of conditions
TT5100 CVD coated	P20 – P35 M20 – M35	• Wide range of turning for mild steel, low carbon steel, low carbon alloy steel and stainless steel
TT9225 CVD coated	M15 – M30 S15 – S30	• General turning of stainless steel and heat resistant super alloy
TT9020 PVD coated	P20 – P40 M20 – M40	• General turning of small parts for steel and stainless steel

Grades

Carbide grades

Grades	ISO	Characteristics & applications
TT4430 PVD coated	M20 – M40 P20 – P40 S20 – S40	<ul style="list-style-type: none"> General turning of small parts for stainless steel, steel and titanium alloy
TT9080 PVD coated	M20 – M40 P20 – P40 S20 – S40	<ul style="list-style-type: none"> General turning of stainless steel, steel and heat resistant super alloy
TT8135B CVD coated	P25 – P40	<ul style="list-style-type: none"> Interrupted turning of steel in low speed conditions
TT7100 CVD coated	P30 – P45	<ul style="list-style-type: none"> Heavy interrupted turning of steel
TT9235 CVD coated	M25 – M40 S25 – S40	<ul style="list-style-type: none"> Interrupted turning of stainless steel and heat resistant super alloy in low speed conditions
TT8080 PVD coated	M30 – M50 P30 – P50 S30 – S50	<ul style="list-style-type: none"> Interrupted and rough turning of stainless steel and steel Interrupted turning of heat resistant super alloys in low speed conditions
TT8020 PVD coated	M30 – M50 P30 – P50 S30 – S50	<ul style="list-style-type: none"> Low speed turning of stainless steel, heat resistant super alloys and low carbon steel
PV3010 Cermet PVD coated	P05 – P20 M05 – M20 K05 – K20	<ul style="list-style-type: none"> Good surface finish turning of steel, stainless steel and cast iron in high speed conditions
CT3000 Cermet uncoated	P10 – P20 M10 – M20 K10 – K20	<ul style="list-style-type: none"> Excellent surface finish turning of steel, stainless steel and cast iron
K10 Carbide	K05 – K15 N05 – N15 S05 – S15	<ul style="list-style-type: none"> General turning of cast iron, non-ferrous materials of aluminum and titanium alloy

Grades

CBN, PCD, Ceramic grades











Grades	ISO	Characteristics & applications
TB610 CBN	H05 – H10	• High speed continuous turning of hardened steel
TB2015 CBN	H10 – H20	• Light interrupted turning of hardened steel
TB650 CBN	H10 – H20	• General turning of hardened steel
TB670 CBN	H20 – H30	• Medium interrupted turning of hardened steel
TB7015 CBN	H25 – H35 K10 – K20	• High speed turning of cast iron and general turning of carbide roll
TB7020 Solid CBN	K10 – K25	• High speed and light interrupted turning of cast iron. Solid CBN insert
TB730 CBN	K05 – K10 P10 – P20	• General turning of sintered or powder metals
AW120 Ceramic, Al ₂ O ₃ +ZrO ₂	K05 – K15	• High speed continuous turning of white cast iron
AB2010 Ceramic, PVD coated	H05 – H10	• High speed finish turning of hardened steel
AB20 Ceramic, Al ₂ O ₃	H05 – H15	• Continuous and finish turning of hardened steel
AB30 Ceramic, Al ₂ O ₃	H10 – H15 K05 – K15	• General turning of hardened steel under HRC 55 and cast iron
TC430 Ceramic, Whisker	S05 – S15	• High speed turning of super alloys especially for Ni-based super alloy
TC3020 Ceramic, SiAlON	S15 – S25	• General turning and milling of super alloy
TC3030 Ceramic, SiAlON	S25 – S35	• Rough turning and milling of super alloy
AS500 Ceramic, SiAlON	K15 – K25	• General and light interrupted turning of gray cast iron
SC10 Ceramic, CVD coated	K25 – K35	• General turning of ductile cast iron
AS10 Ceramic, Si ₃ N ₄	K25 – K35	• Interrupted turning of gray cast iron
TD1010 PCD	N05 – N15	• Bi-modal composition for high speed turning of non-ferrous materials, high Si aluminum alloy, ceramic and sintered tungsten carbide
TD1020 PCD	N10 – N25	• General turning of non-ferrous materials and finish turning of carbide roll
TD1030 PCD	N20 – N35	• Low Si aluminum alloys and composite plastics (CFRP, GFRP)

Recommendations for Chip Breakers









ISO Negative inserts







For steel

	← Stable  Unstable →
Finishing	   
Medium	   
Roughing	 





For stainless steel

	← Stable  Unstable →
Finishing	
Medium	   
Roughing	



For super alloys

	← Stable  Unstable →
Finishing	
Medium	   
Roughing	

For cast iron

	← Stable  Unstable →
Finishing	
Medium	 
Roughing	 

For aluminum







	← Stable  Unstable →
Finishing	
Medium	 
Roughing	

Recommendations for Chip Breakers







ISO Positive inserts



For steel

	← Stable  Unstable →
Finishing	  FA FG
Medium	   FM PC MT
Roughing	



For stainless steel

	← Stable  Unstable →
Finishing	  FA FG
Medium	 PC
Roughing	



For super alloys

	← Stable  Unstable →
Finishing	 FG
Medium	 PC
Roughing	

For cast iron

	← Stable  Unstable →
Finishing	
Medium	 MT
Roughing	

For aluminum

	← Stable  Unstable →
Finishing	
Medium	 GT-FL
Roughing	

Recommendations for Chip Breakers



Chip breakers for Swiss turn (Ground type)

ISO Positive inserts









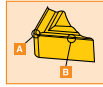











Finishing	<p>SL</p>
Finishing-Medium	<p>SA SM</p>
Roughing	<p>SH ST</p>

Chip Breakers



Negative inserts



Chip breaker name and geometry		Applications and features
FA	 <p>CNMG 1204</p>  	<ul style="list-style-type: none"> • For super finish applications • Steel, stainless steel and heat resistant alloy machining • Excellent chip control
EA	 <p>CNMG 1204</p>  	<ul style="list-style-type: none"> • For finishing applications • Exotic materials • Excellent chip control at low feeds and depths of cut
FLP	 <p>CNMG 1204</p>  	<ul style="list-style-type: none"> • For finishing applications for steel machining • Wide supporting area
FG	 <p>CNMG 1204</p>  	<ul style="list-style-type: none"> • For finish and semi finish applications • Steel, stainless steel and cast iron machining • Low cutting forces
SF	 <p>CNMG 1204</p>  	<ul style="list-style-type: none"> • For finishing applications • Stainless steel and heat resistant alloy machining • Low cutting forces
FX	 <p>VNMG 1604</p>  	<ul style="list-style-type: none"> • For finishing applications on mild steels • Narrow chip breaker design for optimal chip control
FC	 <p>CNMG 1204</p>  	<ul style="list-style-type: none"> • Ideal for finishing applications • Low carbon steel & low carbon alloy steel • Effective chip breaking in both turning and facing operations

Chip Breakers

Negative inserts

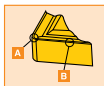









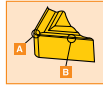



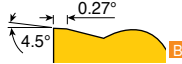

Chip breaker name and geometry		Applications and features
MLP	<p>CNMG 1204</p>	<ul style="list-style-type: none"> • For semi-finishing and medium applications on steels • Wave cutting edge
MC	<p>CNMG 1204</p>	<ul style="list-style-type: none"> • For medium applications • Steel and cast iron machining • Strong rake geometry • Excellent chip control on medium turning applications
MGS	<p>CNMG 1204</p>	<ul style="list-style-type: none"> • Low cutting resistance and heat generation in high-temperature alloy machining • High rake angle for smooth chip formation
ML	<p>CNMG 1204</p>	<ul style="list-style-type: none"> • For medium light applications • Stainless steel, steel and aluminum • Very high positive rake geometry to minimize built-up-edge and cutting forces
MP	<p>CNMG 1204</p>	<ul style="list-style-type: none"> • For medium machining applications • Steel and stainless steel • High positive rake geometry to optimize machining and provide stable machining conditions
EM	<p>CNMG 1204</p>	<ul style="list-style-type: none"> • For medium applications • Stainless steel machining • Sharp land design for low cutting force
MGP	<p>CNMG 1204</p>	<ul style="list-style-type: none"> • Wide range for medium application on steels • Wide groove and several dimples

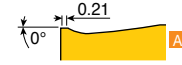
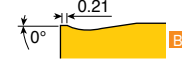
Chip Breakers

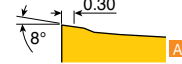
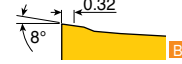

Negative inserts

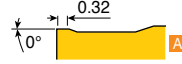
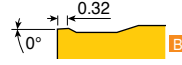

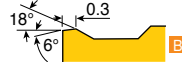







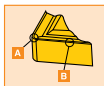



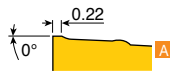

Chip breaker name and geometry		Applications and features
PC	 <p>CNMG 1204</p>  	<ul style="list-style-type: none"> • For medium to semi-finishing applications • Steel & Automotive component • Positive geometry • Excellent chip control on medium applications
MT	 <p>CNMG 1204</p>  	<ul style="list-style-type: none"> • For medium rough applications • Steel, cast iron and stainless steel • Tough rake angle for general use
No Notation	 <p>CNMG 1204</p>  	<ul style="list-style-type: none"> • For medium rough applications • Steel and cast iron machining • Strong rake geometry • Suitable for manual lathes
ET	 <p>CNMG 1204</p>  	<ul style="list-style-type: none"> • For roughing applications on exotic materials • Low cutting force • Wide chip control range when roughing
RGP	 <p>CNMG 1204</p>  	<ul style="list-style-type: none"> • For roughing applications on steels • Reliable cutting edge with low cutting force
RT	 <p>CNMG 1906</p>  	<ul style="list-style-type: none"> • For roughing applications • Steel and cast iron machining • Very strong rake geometry
KT	 <p>CNMG 1204</p>  	<ul style="list-style-type: none"> • For roughing applications on cast iron • Stable broad supporting area • Reliable, uniform performance

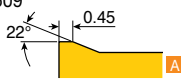
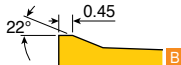
Chip Breakers

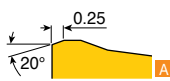

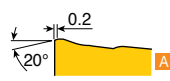
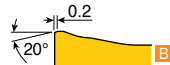
Negative inserts

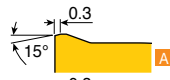
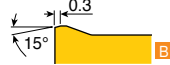

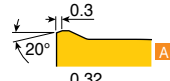
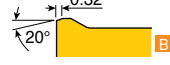

Chip breaker name and geometry		Applications and features
RX	 <p>CNMM 1906</p>  	<ul style="list-style-type: none"> • For semi heavy roughing applications • Steel, stainless steel and cast iron machining • Strong cutting edge with flat land • Low cutting force
RH	 <p>CNMM 1906</p>  	<ul style="list-style-type: none"> • For roughing applications • Steel, stainless steel and cast iron machining • Very strong rake geometry
EH	 <p>CNMM 2509</p>  	<ul style="list-style-type: none"> • Heavy turning for stainless and mild steel • Low cutting force in stainless steel machining • Reliable & uniform performance • Excellent chip control due to the specially designed chip breaker geometry • Single sided insert
HT	 <p>CNMM 1906</p> 	<ul style="list-style-type: none"> • For heavy roughing applications • Low cutting force for low horse power machines • Excellent chip control due to changeable land and a flexible chip breaker
HD	 <p>CNMD 2509</p>  	<ul style="list-style-type: none"> • For heavy roughing applications • For all kinds of shafts, connecting-rods and ship building components • Flexible chip breaker offers excellent chip evacuation
HY	 <p>CNMM 2509</p>  	<ul style="list-style-type: none"> • For heavy roughing applications • For large depth of cut and high feed • Strong cutting edge credit to a wide land and large land angle
HZ	 <p>CNMM 2509</p>  	<ul style="list-style-type: none"> • For heavy roughing applications • For large depth of cut and high feed • Extremely strong cutting edge credit to a wide land and large land angle • Suitable for high cutting conditions

Chip Breakers

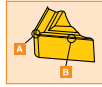
Negative inserts

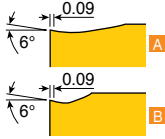

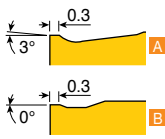

Chip breaker name and geometry		Applications and features
WS	 <p>wiper</p> <p>CNMG 1204</p> 	<ul style="list-style-type: none"> • For super finish applications • Steel, cast iron and stainless steel machining • Excellent chip control and low cutting forces
WT	 <p>wiper</p> <p>CNMG 1204</p> 	<ul style="list-style-type: none"> • For medium to rough machining applications • Steel, cast iron and stainless steel machining • Stable cutting and low cutting forces at high feed rates

Chip Breakers

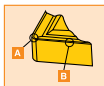
Negative inserts



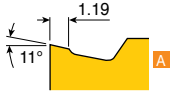

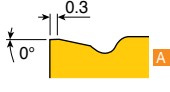
KNUX type

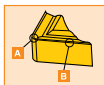
Chip breaker name and geometry		Applications and features
11	 <p>KNUX 1604</p> 	<ul style="list-style-type: none"> • For medium light to medium applications • Steel and stainless steel machining • Positive rake geometry to minimize cutting forces • Excellent chip control
12	 <p>KNUX 1604</p> 	<ul style="list-style-type: none"> • For medium to medium rough applications • Steel and stainless steel • Strong rake geometry • Wide chip control range

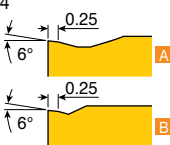

HNMG type

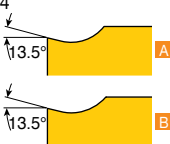







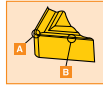

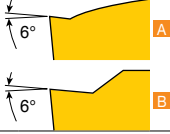

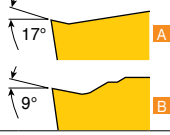

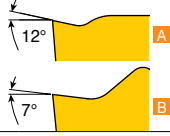
Chip breaker name and geometry		Applications and features
GU	 <p>HNMG 0504</p> 	<ul style="list-style-type: none"> • For medium applications • For general turning of steels and cast irons • Strong rake geometry
SU	 <p>HNMG 0504</p> 	<ul style="list-style-type: none"> • For exotic materials • Stainless steels, super alloys, low carbon steels, low carbon alloy steel machining • Sharp geometry to minimize built-up edge

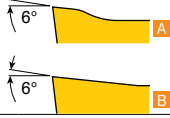
Chip Breakers

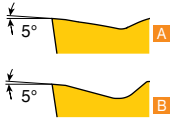

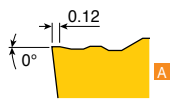
Positive inserts-pressed

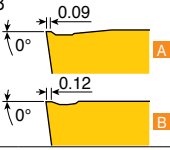



Chip breaker name and geometry		Applications and features
FA	 <p>DCMT 11T3</p> 	<ul style="list-style-type: none"> • For super finish applications • Very tight chipbreaker • Excellent chip control
FG	 <p>CCMT 09T3</p> 	<ul style="list-style-type: none"> • For finish to medium light applications • Steel and stainless steel machining • Low cutting forces • Excellent chip control
FX	 <p>VBMT 1604</p> 	<ul style="list-style-type: none"> • For finishing applications on mild steels • Narrow chip breaker design for optimal chip control
PC	 <p>CCMT 09T3</p> 	<ul style="list-style-type: none"> • For medium applications • Suitable for a wide variety of materials • Low cutting force
FM	 <p>CCMT 09T3</p> 	<ul style="list-style-type: none"> • Medium and semi-finishing machining for steel and stainless steel • Precision machining • Low cutting force chip breaker geometry
MT	 <p>CCMT 09T3</p> 	<ul style="list-style-type: none"> • For medium to medium rough applications • Steel, stainless steel and cast iron machining • Negative rake geometry for general use
WT	 <p>CCMT 09T3</p> 	<ul style="list-style-type: none"> • For medium to rough machining applications • Steel, cast iron and stainless steel machining • Stable cutting and low cutting forces at high feed rates
PMR-	 <p>TPMR 1103</p> 	<ul style="list-style-type: none"> • For medium to medium rough applications • Steel, stainless steel and cast iron • Positive rake geometry

Chip Breakers

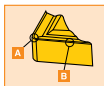

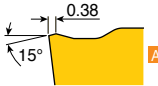

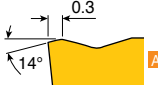

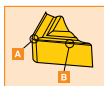

Positive inserts-pressed



Chip breaker name and geometry		Applications and features
RA	 <p>RCMX 3209</p> 	<ul style="list-style-type: none"> • For heavy and interrupted machining applications • Steel, stainless steel and cast iron machining • Optimized chip groove geometry
No Notation	 <p>RCMX 1204</p> 	<ul style="list-style-type: none"> • For high feed roughing applications • Steel, stainless steel and cast iron machining • Strong rake geometry

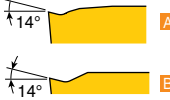

Positive inserts-ground

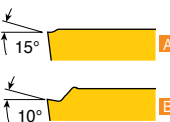





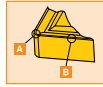

Chip breaker name and geometry		Applications and features
FF	 <p>CCGT 0301</p> 	<ul style="list-style-type: none"> • For finish to medium applications • For small component machining • Excellent surface finish
GF	 <p>CCET 0602</p> 	<ul style="list-style-type: none"> • For super finish applications • Steel, stainless steel and alloy steel machining
GW	 <p>CCET 0602</p> 	<ul style="list-style-type: none"> • For super finish applications • Wiper geometry for good surface finish • Steel, stainless steel and alloy steel machining
FGS	 <p>VBGT 1604</p> 	<ul style="list-style-type: none"> • Lower cutting resistance and heat generation in heat resistant super alloys machining • High rake angle for smooth chip formation
SL	 <p>CCGT 09T3</p> 	<ul style="list-style-type: none"> • High performance in low depth of cut and low feed machining • Excellent chip segmentation due to wave geometry edge and special inclined design

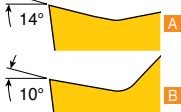
Chip Breakers

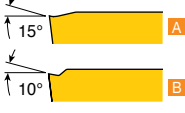

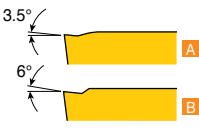
Positive inserts-ground

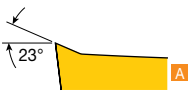

Chip breaker name and geometry		Applications and features
SA	 <p>CCGT 09T3</p> 	<ul style="list-style-type: none"> • For finish to medium applications • Steel & aluminum machining • Low cutting force
SM	 <p>CCGT 09T3</p> 	<ul style="list-style-type: none"> • 1st recommended chip breaker for Swiss type automatic lathe • Stable cutting edge and low cutting resistance
SH	 <p>CCGT 09T3</p> 	<ul style="list-style-type: none"> • Suitable for deep depth of cut machining • Excellent chip control in a wide machining range
FL	 <p>CCGT 1204</p> 	<ul style="list-style-type: none"> • For finish to medium applications • Aluminum machining • Very high positive rake geometry to minimize built-up-edge
ST	 <p>DCGT 11T3</p> 	<ul style="list-style-type: none"> • Capable of deep depth of cut machining up to 5 mm • Low cutting force due to the high positive rake geometry • Stable chip evacuation

Turning Toolholders



P **C** **L** **N** **R**

1 2 3 4 5

1 Clamping system

Lever lock	Top clamp	Screw clamp	Multi lock	T-holder	Wedge clamp	Hook lever

2 Insert shape

C	D	E	H	K	R	S	T	V	W

3 Approach angle

Symbol	Shape	Offset	Symbol	Shape	Offset	Symbol	Shape	Offset
A		x	J		o	V		x
			K		o	W		o
B		x	L		o	X	Special angle	
			M		x	C*		x
D		x	N		x	H*		o
E		x	R		o	Q*		o
F		o	S		o			
G		o	T		o			
			U		o			

* TaeguTec standard

5 Hand of tool

	R: Right hand
	N: Neutral
	L: Left hand

4 Insert clearance angle

N	B	C	P

25 **25** **M** **12** -

6 7 8 9 10 11

6 Shank height

Integers to be preceded by 0
e.g.: H=8mm indicated by 08

7 Shank width

Integers to be preceded by 0
e.g.: B=8mm indicated by 08

8 Tool length

LF (mm)	Symbol	LF (mm)	Symbol
32	A	160	N
40	B	170	P
50	C	180	Q
60	D	200	R
70	E	250	S
80	F	300	T
90	G	350	U
100	H	400	V
110	J	450	W
125	K	500	Y
140	L	Special	X
150	M		

9 Cutting edge length

See page A225

10 Qualified tool

Q: $WF \pm 0.08$, $LF \pm 0.08$

F: $WF \pm 0.08$, $LF \pm 0.08$

B: $WF \pm 0.08$, $LF \pm 0.08$

11 Manufacturer's type designation

Unique to manufacturer

Toolholder Clamping System



T-holder type **T**

- ① Insert
- ② Shim screw
- ③ Shim
- ④ Clamp screw
- ⑤ Clamp
- ⑥ Spring

Top clamp type **C**

- ① Insert
- ② Shim
- ③ Shim pin
- ④ Clamp set

Top clamp type **C**

- ① Insert
- ② Shim
- ③ Shim screw
- ④ Clamp
- ⑤ Clamp screw
- ⑥ Pin and spring
- ⑦ Clamp spring

Multi lock type **M**

- ① Insert
- ② Shim
- ③ Lock pin
- ④ Clamp
- ⑤ Clamp screw

Lever lock type **P**

- ① Insert
- ② Shim
- ③ Lever
- ④ Shim pin
- ⑤ Screw

Screw clamp type **S**

- ① Insert
- ② Shim
- ③ Screw
- ④ Shim screw

Wedge clamp type **W**

- ① Insert
- ② Shim
- ③ Pin screw
- ④ Wedge set

Combi clamp T-holder type **T**

- ① Insert
- ② Shim screw
- ③ Shim
- ④ Clamp screw
- ⑤ Clamp
- ⑥ Spring

Ceramic dimple holder type **T**

- ① Insert
- ② Shim screw
- ③ Shim
- ④ Clamp screw
- ⑤ Clamp
- ⑥ Spring

Hook lever type **H**

- ① Insert
- ② Shim pin
- ③ Shim
- ④ Hook lever
- ⑤ Screw

Top clamp type holders

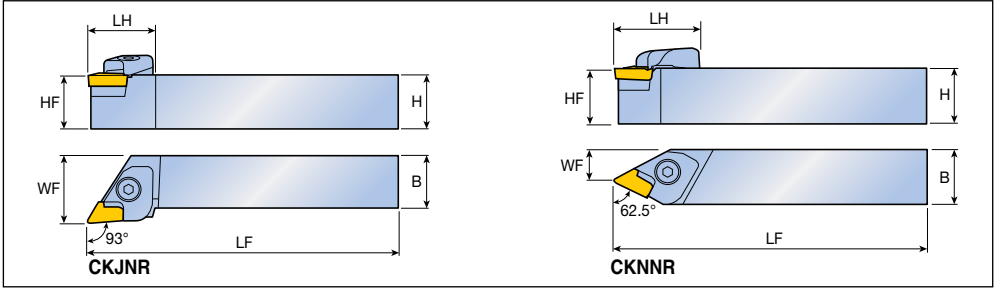

Approach angle	Designation	Dimension (mm)						Insert
		H	HF	B	LF	LH	WF	
93° 	CKJNR/L 2020 K16	20	20	20	125	35	25	KNUX 1604...R/L 11 KNUX 1604...R/L 12 A239
	2020 M16	20	20	20	150	35	25	
	2525 M16	25	25	25	150	32	32	
	3225 P16	32	32	25	170	33.3	32	
	3232 M16	32	32	32	150	33.3	40	
	3232 P16	32	32	32	170	33.3	40	
	4040 R16	40	40	40	200	33.3	50	
62.5° 	CKNNR/L 2525 M16	25	25	25	150	44.7	14.4	
	3225 M16	32	32	25	150	44.7	14.4	

Spare parts

Designation	Clamp	Screw	Clamp spring	Pin	Pin spring	Shim	Shim screw	Wrench
...16	CL 16KR/L 	CLS 16K 	KSP 90 	KP 48S 	KSP 48 	CSK 1604R/L 	FH M3x0.5x10 	L-W 4 L-W 2

Top clamp type holders

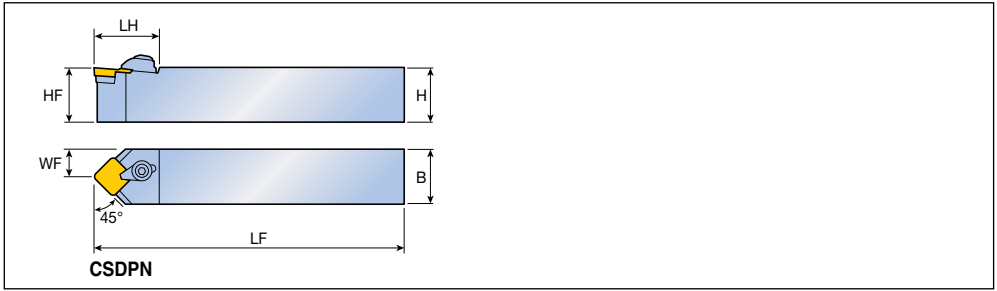



Approach angle	Designation	Dimension (mm)						Insert
		H	HF	B	LF	LH	WF	
45°	CSDPN 1616 H09	16	16	16	100	24	8.0	SPMR,SP...N 0903...
	2020 K12	20	20	20	125	29	10	SPMR,SP...N 1203...
	2525 M12	25	25	25	150	29	12.5	A273, A302

Spare parts



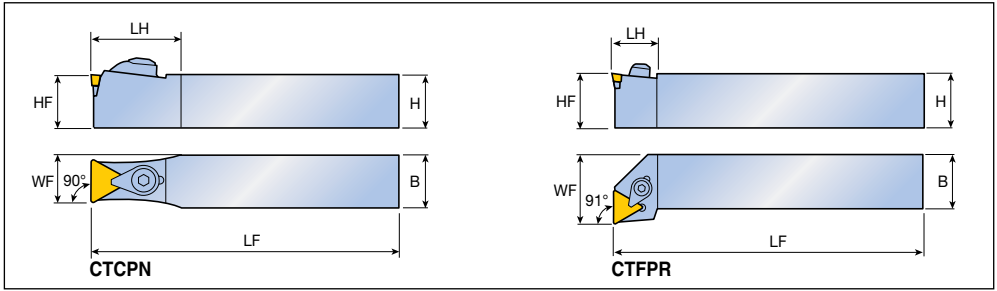

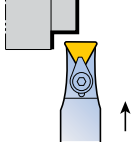

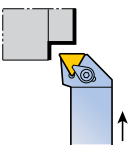

Designation	Clamp	Screw	Shim	Shim pin	Snap ring	Wrench		
...09	CL 2	CLS 2	CSS 32	CSP 3	CSR 2	L-W 2.5		
...12	CL 3	CLS 3	CSS 42	CSP 3	WSR 4	L-W 3		

Top clamp type holders



Approach angle	Designation	Dimension (mm)						Insert
		H	HF	B	LF	LH	WF	
90° 	CTCPN 2009 K11	20	20	9	125	20	9.4	TPMR,TP...N 1103...
	2513 Q16	25	25	13	180	30	14.1	TPMR,TP...N 1603... 
	2525 M22	25	25	25	150	50	19.4	TPMR,TP...N 2204... A279-A280,
91° 	CTFPR/L 1616 H11	16	16	16	100	14.4	20	TPMR,TP...N 1103...
	2020 K11	20	20	20	125	16	25	
	2020 K16	20	20	20	125	20	25	TPMR,TP...N 1603...
	2525 M16	25	25	25	150	20	32	

Spare parts

Designation	Clamp			Screw		Shim	Shim pin	Snap ring	Wrench
									
CTCPN ...11	CL 2C	-	-	CLS 2C	-	-	-	CSR 2C	L-W 2.5
CTCPN ...16	CL 3C	-	-	CLS 3C	-	CST 32	CSP 3	CSR 2	L-W 3
CTCPN ...22	-	CLM 12	-	-	XNSM 0825	CST 43	CSP 16K	CSR 4	L-W 4
CTFPR/L...11	-	-	CL 2	CLS 2	-	-	-	CSR 2	L-W 2.5
CTFPR/L...16	-	-	CL 3	CLS 3	-	CST 32	CSP 3	WSR 4	L-W 3

Top clamp type holders

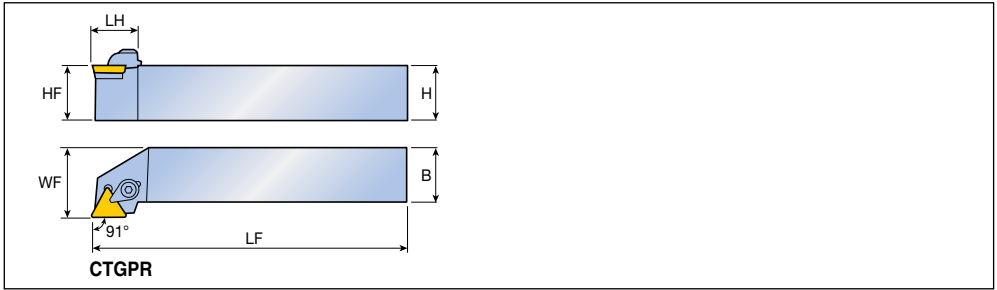

Approach angle	Designation	Dimension (mm)						Insert	
		H	HF	B	LF	LH	WF		
	CTGPR/L 1212 F11	12	12	12	80	19	16	TPMR,TP...N 1103... A279-A280, A302, A313-A314,	
	1616 H11	16	16	16	100	18	20		
	2020 K11	20	20	20	125	19	25		
		2020 K16	20	20	20	125	25	25	TPMR,TP...N 1603...
		2525 M16	25	25	25	150	25	32	TPMR,TP...N 2204...
		2525 M22	25	25	25	150	30	32	
		3232 P22	32	32	32	170	30	40	

Spare parts

Designation	Clamp	Screw	Shim	Shim pin	Snap ring	Wrench		
...11	CL 2	CLS 2	-	-	CSR 2	L-W 2.5		
...16	CL 3	CLS 3	CST 32	CSP 3	WSR 4	L-W 3		
...22	CL 4	CLS 4	CST 43	CSP 16K	CSR 4	L-W 4		

Hook lever type holders

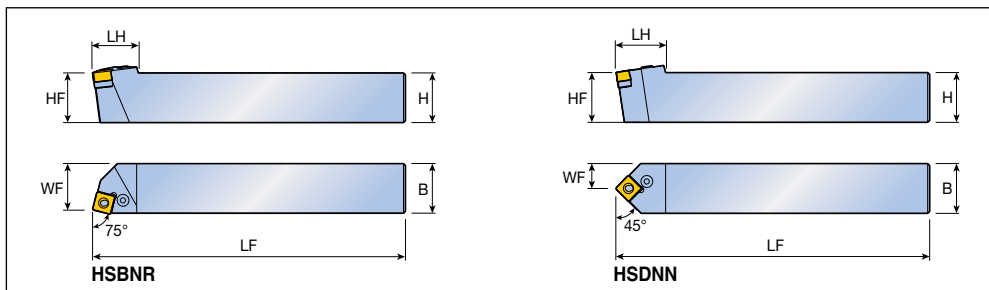

Approach angle	Designation	Dimension (mm)						Insert
		H	HF	B	LF	LH	WF	
75°	HSBNR/L 4040 S3109	40	40	40	250	55	35	SNMD 3109... A241, A242
	5050 T3109	50	50	50	300	55	43	
45°	HSDNN 4040 S3109	40	40	40	250	60	20	SNMD 3109...
	5050 T3109	50	50	50	300	60	25	

Spare parts



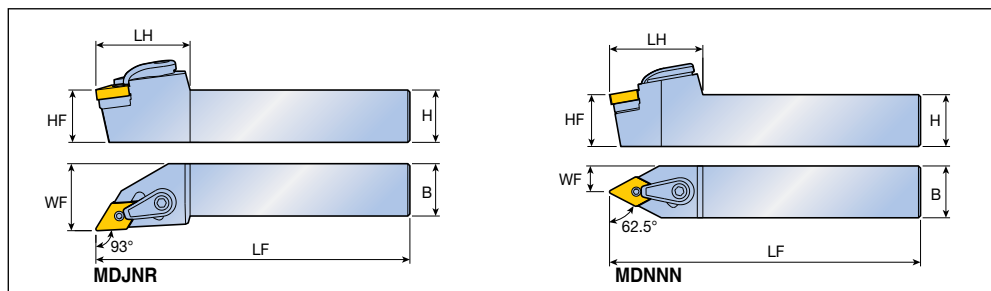

Designation	Lever	Screw	Shim	Shim pin	Wrench		
...3109	LCL 32-NX	LCS 8	LSS 104	LSP 8	L-W 5		

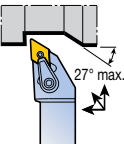
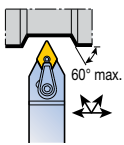
Multi lock type holders



Approach angle	Designation	Dimension (mm)						Insert
		H	HF	B	LF	LH	WF	
93° 	MDJNR/L 2020 K15	20	20	20	125	45	25	DN... 1504...
	2525 M15	25	25	25	150	45	32	A234-A238,
	2020 K15A	20	20	20	125	45	25	DN... 1506...
	2525 M15A	25	25	25	150	45	32	A293, A304
	3232 P15A	32	32	32	170	45	40	
62.5° 	MDNNN 2525 M15	25	25	25	150	45	12.5	DN... 1504...
	3225 P15	32	32	25	170	45	12.5	
	2525 M15A	25	25	25	150	45	12.5	DN... 1506...

Spare parts

Designation	Clamp	Screw	Shim	Lock pin	Wrench			
...15	 CLM 30	 XNSM 0825	 S 45	 MLP 4	 L-W 2.5, L-W 4			
...15A	CLM 30	XNSM 0825	MSD 43	MLP 4-06	L-W 2.5, L-W 4			

Multi lock type holders

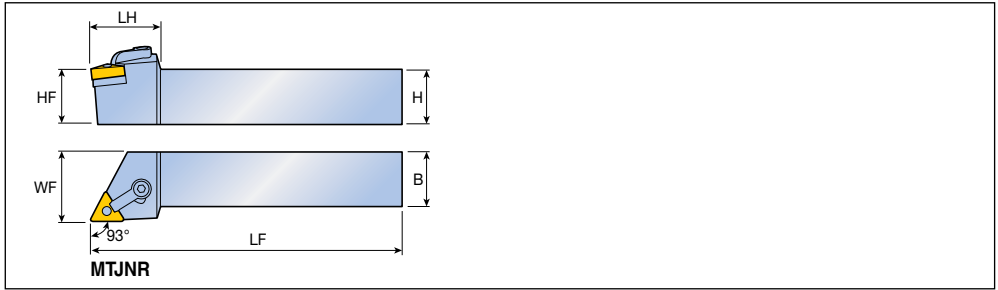

Approach angle	Designation	Dimension (mm)						Insert
		H	HF	B	LF	LH	WF	
93°	MTJNR/L 2020 K16	20	20	20	125	28	25	TN... 1604... A247-A250, A299, A307
	2525 M16	25	25	25	150	28	32	
	2525 M1604	25	25	25	150	28	32	

Spare parts

Designation	Clamp	Screw	Shim	Lock pin	Wrench			
...16	CLM 6 	XNSM 0520 	S 3 	MLP 3 	L-W 2, L-W 2.5 			
...1604	CLM 6	XNSM 0520	S 31	MLP 3	L-W 2, L-W 2.5			

Multi lock type holders

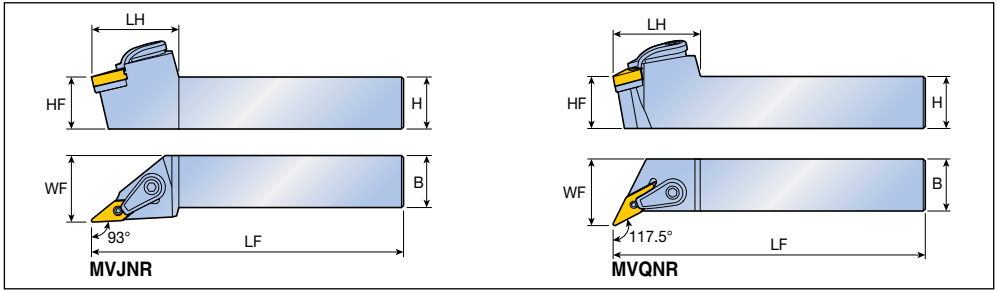

Approach angle	Designation	Dimension (mm)						Insert
		H	HF	B	LF	LH	WF	
93° 	MVJNR/L 2020 K16	20	20	20	125	42	25	VN... 1604... A251-A252, A300, A308
	2525 M16	25	25	25	150	42	32	
	3225 P16	32	32	25	170	42	32	
	3232 P16	32	32	32	170	42	40	
117.5° 	MVQNR/L 2020 K16	20	20	20	125	42	25	
	2525 M16	25	25	25	150	42	32	
	3232 P16	32	32	32	170	42	40	

Spare parts

Designation	Clamp	Screw	Shim	Lock pin	Wrench			
...16	CLM 30	XNSM 0825	IVSN 324	MLP 3	L-W 2, L-W 4			

Lever lock type holders

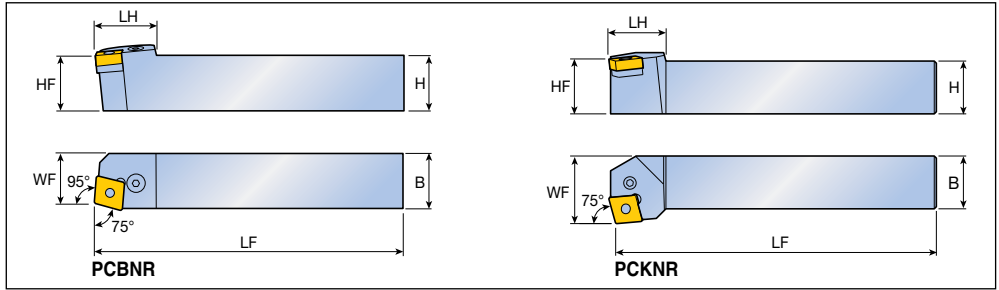

Approach angle	Designation	Dimension (mm)						Insert	
		H	HF	B	LF	LH	WF		
75° 	PCBNR/L 2020 K12	20	20	20	125	28	17.5	CN... 1204... A226-A233, A291, A292, A303	
	2525 M12	25	25	25	150	28	22.5		
	3225 P12	32	32	25	170	28	22.5		
		2525 M16	25	25	25	150	32	22	CN... 1606...
		3232 P16	32	32	32	170	32	27	
		3232 P1906D	32	32	32	170	37	27	CN... 1906...
		4040 S1906D	40	40	40	250	37	37	
		4040 S2509D	40	40	40	250	50	37	CN... 2509...
		5050 T2509D	50	50	50	300	50	47	
75° 	PCKNR/L 2020 K12	20	20	20	125	27	25	CN... 1204...	
	2525 M12	25	25	25	150	24	32		

► CNMD, CNMM, CNMG type insert can be mounted on "-D" holder

Spare parts

Designation	Lever	Screw	Shim	Shim pin	Wrench			
... 12	LCL 4	LCS 4	LSC 42	LSP 4	L-W 3			
... 16	LCL 5	LCS 5	LSC 53	LSP 5	L-W 3			
... 1906	LCL 6D	LCS 25C	LSC 64D	LSP 6	L-W 4			
... 2509	LCL 8	LCS 8	LSC 84D	LSP 8	L-W 5			

► Apply LSC 85D shim when using CN...2507... insert

PCLNR/L PCLNR/L-TB



Lever lock type holders

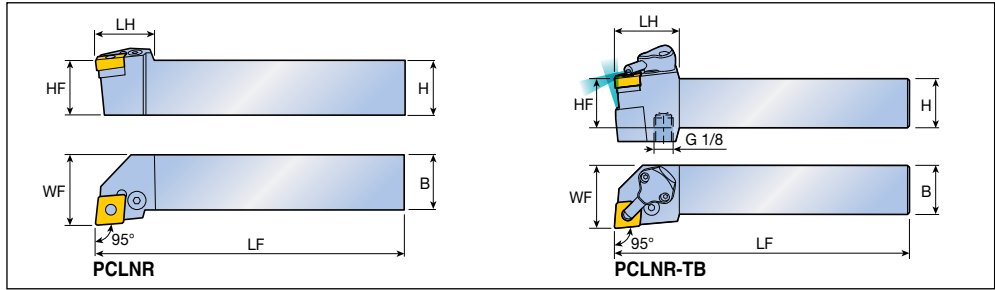

Approach angle	Designation	Dimension (mm)						Insert
		H	HF	B	LF	LH	WF	
 95°	PCLNR/L 1616 H12	16	16	16	100	27	20	CN... 1204... A226-A233, A291, A292, A303
	2020 K12	20	20	20	125	27	25	
	2525 M12	25	25	25	150	27	32	
	3225 P12	32	32	25	170	27	32	
	3232 P12	32	32	32	170	27	40	
	2525 M16	25	25	25	150	33	32	
	3225 P16	32	32	25	170	33	32	
	3232 P16	32	32	32	170	33	40	
	2525 M1906D	25	25	25	150	38	32	
	3225 P1906D	32	32	25	170	38	32	
	3232 P1906D	32	32	32	170	38	40	
	4040 S1906D	40	40	40	250	38	50	
	4040 S2509D	40	40	40	250	47	50	
5050 T2509D	50	50	50	300	47	60		
 95°	PCLNR/L 2525 M12-TB	25	25	25	150	33	32	CN... 1204...
	3232 P12-TB	32	32	32	170	33	40	

► CNMD, CNMM, CNMG type insert can be mounted on "-D" holder

Spare parts

Designation	Lever	Screw	Shim	Shim pin	Cooling unit	O-ring	Wrench	
1616...12	LCL 4	LCS 4S	LSC 42	LSP 4	-	-	-	L-W 3
...12	LCL 4	LCS 4	LSC 42	LSP 4	-	-	-	L-W 3
...16	LCL 5	LCS 5	LSC 53	LSP 5	-	-	-	L-W 3
...1906	LCL 6D	LCS 25C	LSC 64D	LSP 6	-	-	-	L-W 4
...2509	LCL 8	LCS 8	LSC 84D	LSP 8	-	-	-	L-W 5
PCLNR/L...TB	LCS 4	LCS 4	LSC 42	LSP 4	CU-CW-TB	ID 6.4x0.9	T 8	L-W 2, L-W 3

► Apply LSC 85D shim when using CN...2507... insert



► Please refer to A135 page for COOL-BURST accessories

PDJNR/L PDJNR/L-TB

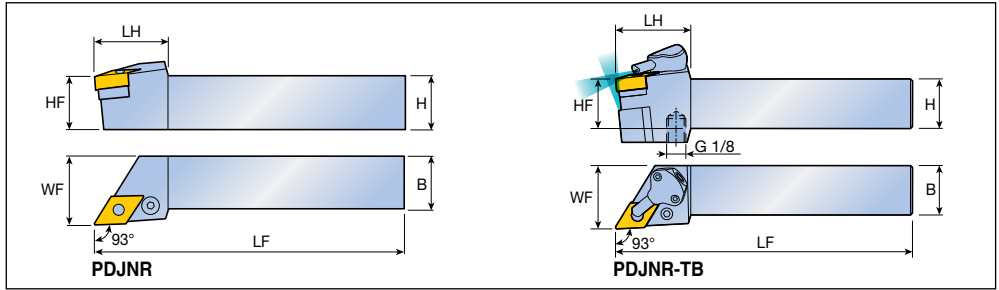

Lever lock type holders

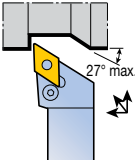

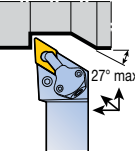
Approach angle	Designation	Dimension (mm)						Insert	
		H	HF	B	LF	LH	WF		
93° 	PDJNR/L 1616 H11	16	16	16	100	30	20	DN... 1104...	
	2020 K11	20	20	20	125	30	25	 A234-A238, A293, A304	
	2525 M11	25	25	25	150	30	32		
	2020 K15	20	20	20	125	34	25		DN... 1506...
	2525 M15	25	25	25	150	34	32		
	3225 P15	32	32	25	170	34	32		
	3232 P15	32	32	32	170	34	40		
		2020 K15A	20	20	20	125	34	25	DN... 1504...
		2525 M15A	25	25	25	150	34	32	
	93°  COOLBURST	PDJNR/L 2525 M1504-TB	25	25	25	150	37	32	DN... 1504...
2525 M1506-TB		25	25	25	150	37	32	DN... 1506...	

Spare parts

Designation	Lever	Screw	Shim	Shim pin	Cooling unit	O-ring	Wrench	
...11	LCL 12C	LCS 3	LSD 32	LSP 3A	-	-	-	L-W 2.5
...15	LCL 4A	LCS 4	LSD 42	LSP 4	-	-	-	L-W 3
...M1504-TB	LCL 4A	LCS 4	LSD 43	LSP 4	CU-D-TB	ID 6.4x0.9	T 8	L-W 2, L-W 3
...M1506-TB	LCL 4A	LCS 4	LSD 42	LSP 4	CU-D-TB	ID 6.4x0.9	T 8	L-W 2, L-W 3

► Please refer to A135 page for COOL-BURST accessories

Lever lock type holders

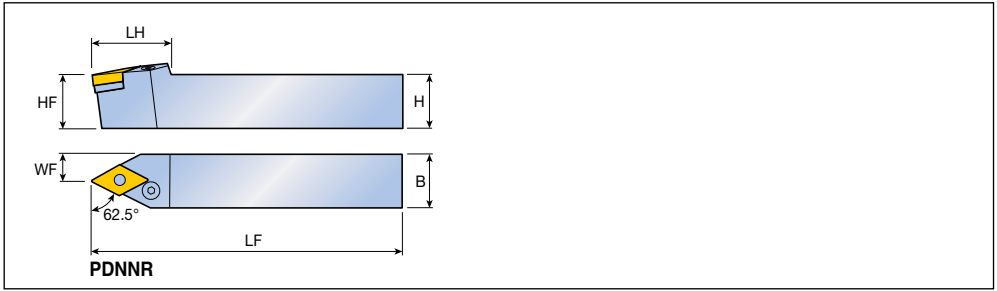

Approach angle	Designation	Dimension (mm)						Insert
		H	HF	B	LF	LH	WF	
62.5°	PDNNR/L 2020 K15	20	20	20	125	36.5	10	DN... 1506... A234-A238, A293, A304
	2525 M15	25	25	25	150	36.5	12	
	3232 P15	32	32	32	170	36.5	16.8	

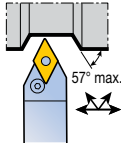

Spare parts

Designation	Lever	Screw	Shim	Shim pin	Wrench			
...15	LCL 4A	LCS 4	LSD 42	LSP 4	L-W 3			

Lever lock type holders

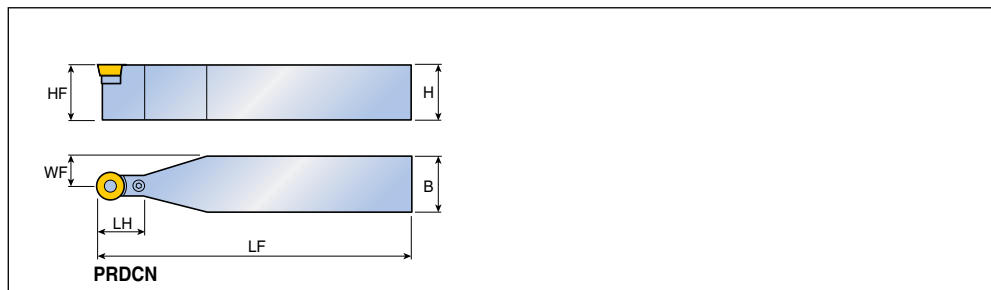

Approach angle	Designation	Dimension (mm)						Insert
		H	HF	B	LF	LH	WF	
	PRDCN 2020 M10	20	20	20	150	30	10.0	RC...X 1003...
	2525 M10	25	25	25	150	30	12.5	RC...X 1204...
	2020 K12	20	20	20	125	30	10.0	
	2525 M12	25	25	25	150	30	12.5	
	3225 Q12	32	32	25	180	30	12.5	RC...X 1606...
	2525 Q16	25	25	25	180	30	12.5	
	3225 Q16	32	32	25	180	30	12.5	
	3232 Q16	32	32	32	180	30	16.0	RC...X 2006...
	3232 S20	32	32	32	250	40	16.0	
	4040 S20	40	40	40	250	40	20.0	
	4040 S25	40	40	40	250	50	20.0	RC...X 2507...
	4040 T25	40	40	40	300	50	20.0	RC...X 3209...
	5050 U32	50	50	50	350	60	25.0	

Spare parts

Designation	Lever	Screw	Shim	Shim pin	Wrench		
...10	LCL 10C	LCS 2	LSR 32	LSP 3A	L-W 2		
...12	LCL 12C	LCS 3	LSR 1203	LSP 3A	L-W 2.5		
...16	LCL 16C	LCS 16C	LSR 1604	LSP 16C	L-W 2.5		
...20	LCL 20C	LCS 5	LSR 2004	LSP 5	L-W 3		
...25	LCL 25C	LCS 25C	LSR 2506	LSP 6	L-W 4		
...32	LCL 32C	LCS 8	LSR 3206	LSP 8	L-W 5		

Lever lock type holders

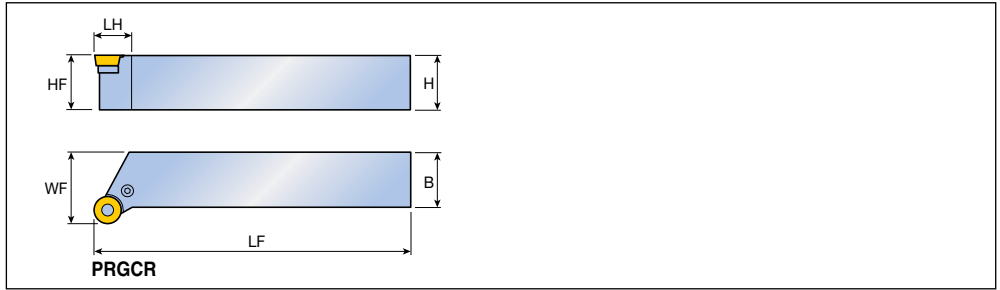

Approach angle	Designation	Dimension (mm)						Insert
		H	HF	B	LF	LH	WF	
 90°	PRGCR/L 2020 K10	20	20	20	125	14.5	25	RC...X 1003... A271
	2525 M10	25	25	25	150	17.5	32	
	3225 P10	32	32	25	170	17	32	
	2020 K12	20	20	20	125	18	25	RC...X 1204...
	2525 M12	25	25	25	150	18	32	
	3225 P12	32	32	25	170	18	32	
	2525 M16	25	25	25	150	23	32	RC...X 1606...
	3225 P16	32	32	25	170	23	32	
	3232 P16	32	32	32	170	23	40	
	4040 P16	40	40	40	170	23	50	RC...X 2006... RC...X 2507... RC...X 3209...
	3232 P20	32	32	32	170	27.5	40	
	4040 S25	40	40	40	250	33.5	50	
	4040 S32	40	40	40	250	41	50	

Spare parts

Designation	Lever	Screw	Shim	Shim pin	Wrench			
...10	LCL 10C	LCS 2	LSR 32	LSP 3A	L-W 2			
...12	LCL 12C	LCS 3	LSR 1203	LSP 3A	L-W 2.5			
...16	LCL 16C	LCS 16C	LSR 1604	LSP 16C	L-W 2.5			
...20	LCL 20C	LCS 5	LSR 2004	LSP 5	L-W 3			
...25	LCL 25C	LCS 25C	LSR 2506	LSP 6	L-W 4			
...32	LCL 32C	LCS 8	LSR 3206	LSP 8	L-W 5			

Lever lock type holders

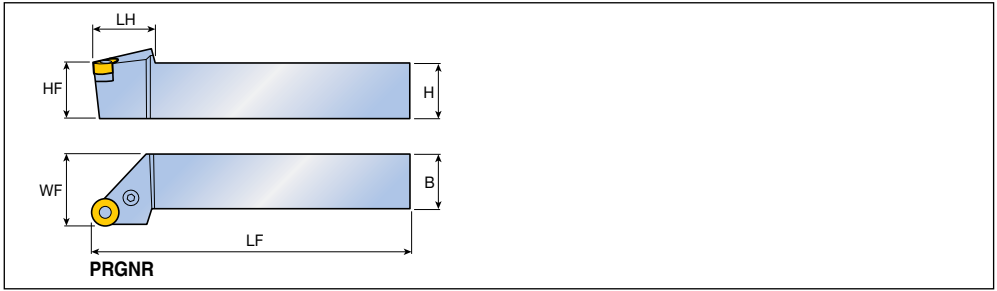

Approach angle	Designation	Dimension (mm)						Insert
		H	HF	B	LF	LH	WF	
90°	PRGNR/L 2525 M12	25	25	25	150	28	32	RNMG 120400
	3225 P15	32	32	25	170	35	32	RNMG 150600
	3232 P19	32	32	32	170	38	40	RNMG 190600

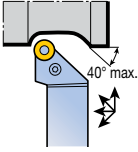



Spare parts

Designation	Lever	Screw	Shim	Shim pin	Wrench			
...12	LCL 4	LCS 4	LSR 42	LSP 4	L-W 3			
...15	LCL 5	LCS 5	LSR 53	LSP 5	L-W 3			
...19	LCL 6D	LCS 6	LSR 63	LSP 6	L-W 4			

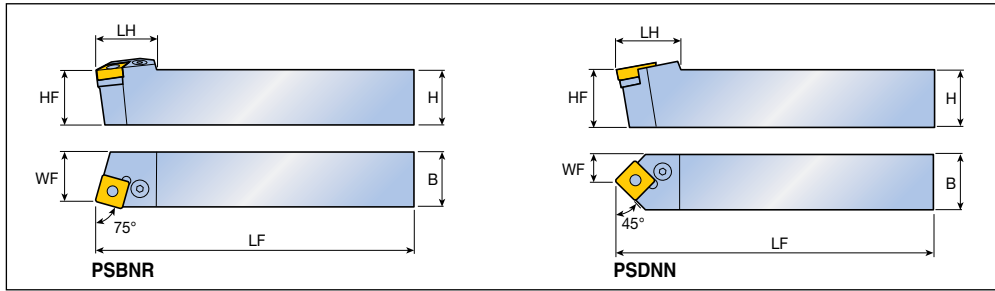
Lever lock type holders

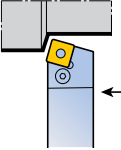

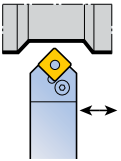
Approach angle	Designation	Dimension (mm)						Insert	
		H	HF	B	LF	LH	WF		
75° 	PSBNR/L 2020 K12	20	20	20	125	28	17	SN... 1204...  A241-A246, A296, A297, A306	
	2525 M12	25	25	25	150	28	22		
	3225 P12	32	32	25	170	28	22		
	2525 M15	25	25	25	150	34	22		SN... 1506...
	3232 P1906D	32	32	32	170	39	27		SN... 1906...
	4040 S1906D	40	40	40	250	39	35		
	4040 S2509D	40	40	40	250	48	35		SN... 2509...
	5050 T2509D	50	50	50	300	48	43		
45° 	PSDNN 2020 K12	20	20	20	125	28	10.0	SN... 1204...	
	2525 M12	25	25	25	150	28	12.5		
	3225 P12	32	32	25	170	28	12.5		
	2020 K15	20	20	20	125	34	10.0	SN... 1506...	
	2525 M15	25	25	25	150	34	12.5		
	3225 P1906D	32	32	25	170	40.5	12.5	SN... 1906...	
	3232 P1906D	32	32	32	170	40.5	16.0		
	4040 S1906D	40	40	40	250	40.5	20.0		
	5050 S1906D	50	50	50	250	40.5	25.0		
	4040 S2509D	40	40	40	250	49	20.0	SN... 2509...	
5050 T2509D	50	50	50	300	49	25.0			

▶ SNMD, SNMM, SNMG type insert can be mounted on "-D" holder

Spare parts

Designation	Lever	Screw	Shim	Shim pin	Wrench			
...12	LCL 4	LCS 4	LSS 42	LSP 4	L-W 3			
...15	LCL 5	LCS 5	LSS 53	LSP 5	L-W 3			
...1906	LCL 6D	LCS 25C	LSS 64D	LSP 6	L-W 4			
...2509	LCL 8	LCS 8	LSS 84D	LSP 8	L-W 5			

▶ Apply LSC 85D shim when using CN...2507... insert

Lever lock type holders

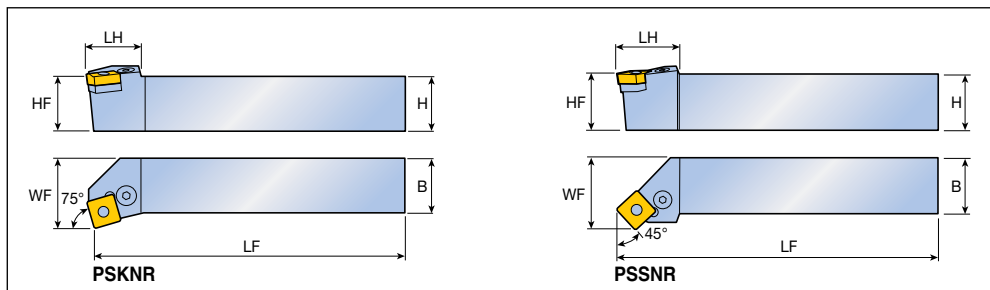

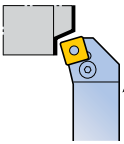
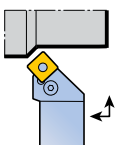
Approach angle	Designation	Dimension (mm)						Insert
		H	HF	B	LF	LH	WF	
75° 	PSKNR/L 2020 K12	20	20	20	125	25	25	SN... 1204...
	2525 M12	25	25	25	150	25	32	SN... 1506...
	2525 M15	25	25	25	150	32	32	
	3232 P15	32	32	32	170	32	40	SN... 1906...
	3232 P1906D	32	32	32	170	38	40	SN... 1906...
	4040 S1906D	40	40	40	250	38	50	SN... 2509...
	4040 S2509D	40	40	40	250	42	50	
	5050 T2509D	50	50	50	300	42	60	
45° 	PSSNR/L 2020 K12	20	20	20	125	30	25	SN... 1204...
	2525 K12	25	25	25	125	30	32	SN... 1506...
	2525 M12	25	25	25	150	30	32	
	3225 P12	32	32	25	170	30	32	SN... 1506...
	3232 P12	32	32	32	170	32	40	
	3232 P15	32	32	32	170	37	40	SN... 1906...
	3232 P1906D	32	32	32	170	42	40	SN... 1906...
	4040 S1906D	40	40	40	250	42	50	SN... 2509...
	4040 S2509D	40	40	40	250	53	50	

▶ SNMD, SNMM, SNMG type insert can be mounted on "-D" holder

Spare parts

Designation	Lever	Screw	Shim	Shim pin	Wrench			
...12	LCL 4	LCS 4	LSS 42	LSP 4	L-W 3			
...15	LCL 5	LCS 5	LSS 53	LSP 5	L-W 3			
...1906	LCL 6D	LCS 25C	LSS 64D	LSP 6	L-W 4			
...2509	LCL 8	LCS 8	LSS 84D	LSP 8	L-W 5			

▶ Apply LSC 85D shim when using CN...2507... insert

Lever lock type holders

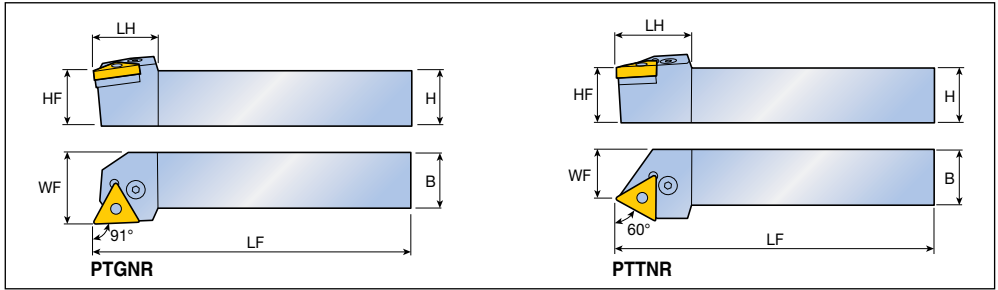

Approach angle	Designation	Dimension (mm)						Insert	
		H	HF	B	LF	LH	WF		
91° 	PTGNR/L 1010 E11	10	10	10	70	15	12	TN... 1103... A247-A250, A299, A307	
	1212 F11	12	12	12	80	15	16		
	2525 M11	25	25	25	150	30	32		
	1616 H16	16	16	16	100	22	20		TN... 1604...
	2020 K16	20	20	20	125	22	25		
	2525 M16	25	25	25	150	22	32		
	3232 P16	32	32	32	170	22	40		
	2525 M22	25	25	25	150	29	32		TN... 2204...
	3232 P22	32	32	32	170	29	40		
60° 	PTTNR/L 1616 H16	16	16	16	100	24	13	TN... 1604...	
	2020 K16	20	20	20	125	24	17		
	2525 M16	25	25	25	150	24	22		

Spare parts

Designation	Lever	Screw	Shim	Snap ring	Shim pin	Wrench		
...11	LCL 2B	LCS 2B	-	LSR 2B	-	L-W 2		
...16	LCL 3	LCS 3	LST 31.8	-	LSP 3A	L-W 2.5		
...22	LCL 4	LCS 4	LST 42	-	LSP 4	L-W 3		

SCACR/L-SH SCACR/L-SH-TB



Screw type holders

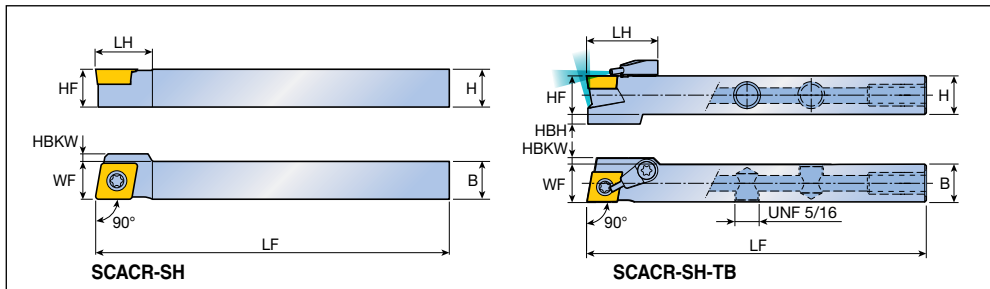

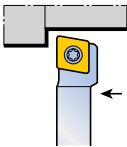
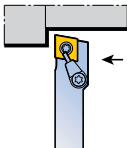
Approach angle	Designation	Dimension (mm)								Insert
		H	HF	HBH	B	LF	LH	WF	HBKW	
 90°	# SCACR/L 1010 K06-SH	10	10	-	10	125	10	10	-	CC... 0602...
	1010 K09-SH	10	10	-	10	125	15	10	2	CC... 09T3...
	1212 K09-SH	12	12	-	12	125	15	12	-	
	1616 K09-SH	16	16	-	16	125	16	16	-	
 90°	# SCACR/L 1212 K09-SH-TB	12	12	3	12	125	23	12	2	
	1616 K09-SH-TB	16	16	-	16	125	23	16	-	







 A260-A263,

 A310

► #: TOP-MINI holders

Spare parts

Designation	Screw	Cooling unit	Plug	Wrench			
							
...06-SH	SO 250651	-	-	T 7	-		
...09-SH	SO 350801	-	-	T 15	-		
SCACR/L-SH-TB	SO 350801	S-CU-TB	PLG 5/16 UNF	T 15	L-W 5/32		

► Please refer to A135 page for COOL-BURST accessories

SCLCR/L-SH SCLCR/L-SH-TB



Screw type holders

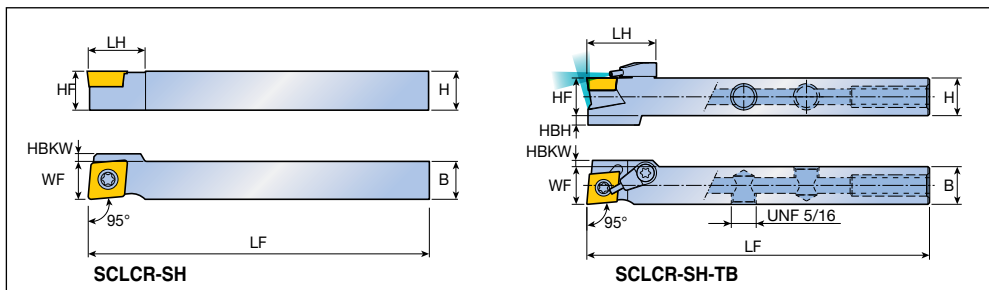

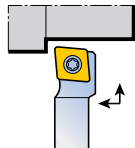
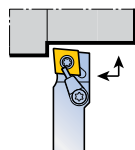



Approach angle	Designation	Dimension (mm)								Insert	
		H	HF	HBH	B	LF	LH	WF	HBKW		
 95°	# SCLCR/L 0808 K06-SH	8	8	-	8	125	8	8	-	CC... 0602...	
	1010 K06-SH	10	10	-	10	125	10	10	-		
	1010 K09-SH	10	10	-	10	125	15	10	2	CC... 09T3...	
	1212 K09-SH	12	12	-	12	125	15	12	-		
	1616 K09-SH	16	16	-	16	125	16	16	-		
 95°	# SCLCR/L 1212 K09-SH-TB	12	12	3	12	125	23	12	2		
	1616 K09-SH-TB	16	16	-	16	125	23	16	-		



 A260-A263,
 A310

► #: TOP-MINI holders

Spare parts

Designation	Screw	Cooling unit	Plug	Wrench			
							
...06-SH	SO 250651	-	-	T 7	-		
...09-SH	SO 350801	-	-	T 15	-		
SCLCR/L-SH-TB	SO 350801	S-CU-TB	PLG 5/16 UNF	T 15	L-W 5/32		

► Please refer to A135 page for COOL-BURST accessories

Screw type holders

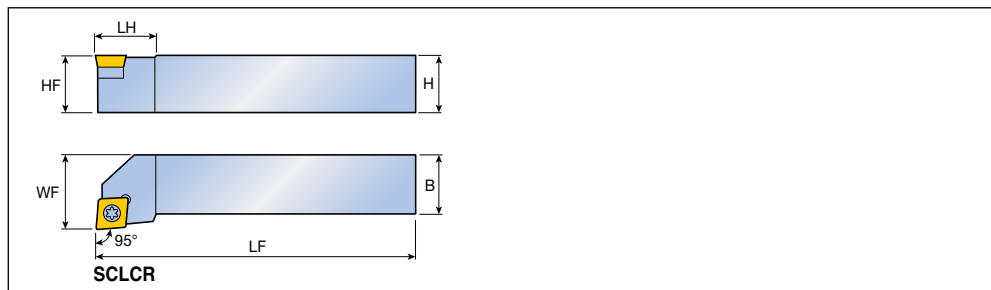

Approach angle	Designation	Dimension (mm)						Insert
		H	HF	B	LF	LH	WF	
	SCLCR/L 0808 F06	8	8	8	80	10	10	CC... 0602...
	1010 F06	10	10	10	80	10	12	CC... 09T3... A260-A263, A310
	1212 F09	12	12	12	80	16	16	
	1616 H09	16	16	16	100	16	20	CC... 1204...
	2020 K09	20	20	20	125	20	25	
	2525 M09	25	25	25	150	20	32	
	2020 K12	20	20	20	125	25	25	
		2525 M12	25	25	25	150	26	32

Spare parts

Designation	Screw	Shim	Shim screw	Wrench			
...06	SO 25065I	-	-	T 7			
...F09	SO 35080I	-	-	T 15			
...09	SO 35124I	SSC 32	SO 50090S	T 15			
...12	SO 45130I	SSC 43N	SO 60105S	T 20			

SDJCR/L-SH SDJCR/L-SH-TB



Screw type holders

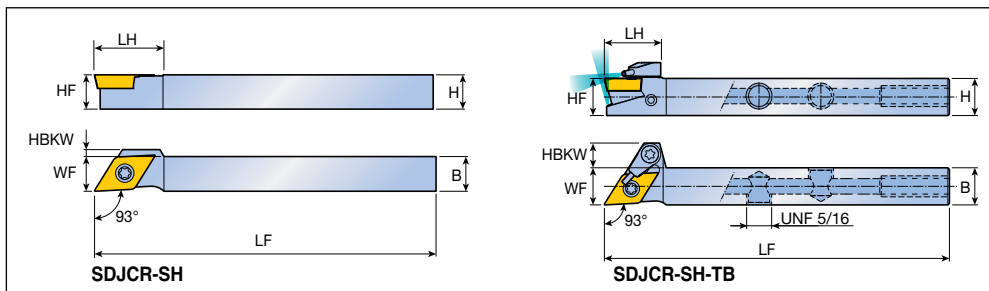

Approach angle	Designation	Dimension (mm)							Insert
		H	HF	B	LF	LH	WF	HBKW	
93° 	# SDJCR/L 0808 K07-SH	8	8	8	125	12.7	8	-	DC... 0702... DC... 11T3... A265-A268, A311
	1010 K07-SH	10	10	10	125	15	10	-	
	1010 K11-SH	10	10	10	125	20	10	2	
	1212 K11-SH	12	12	12	125	20	12	-	
	1616 K11-SH	16	16	16	125	20	16	-	
	2020 K11-SH	20	20	20	125	20	20	-	
93° 	# SDJCR/L 1212 K11-SH-TB	12	12	12	125	19	12	8	
	1616 K11-SH-TB	16	16	16	125	19	16	4	
	2020 K11-SH-TB	20	20	20	125	20	20	-	

► #: TOP-MINI holders

Spare parts

Designation	Screw	Cooling unit	Plug	Wrench	
...07	SO 25065I	-	-	T 7	-
...11-SH	SO 35080I	-	-	T 15	-
SDJCR/L-SH-TB	SO 35080I	S-CU-TB	PLG 5/16 UNF	T 15	L-W 5/32

► Please refer to A135 page for COOL-BURST accessories

Screw type holders

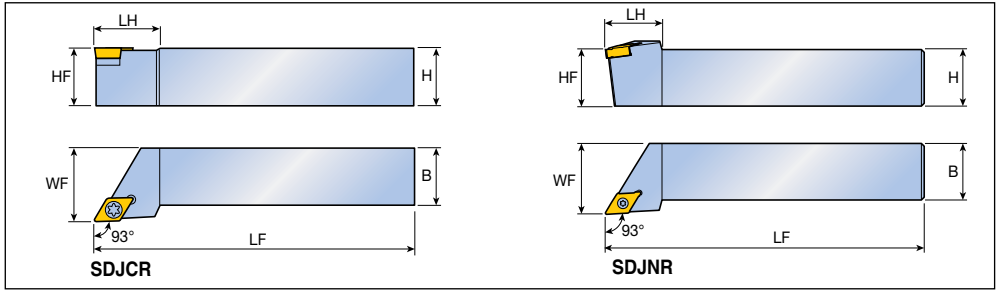

Approach angle	Designation	Dimension (mm)						Insert	
		H	HF	B	LF	LH	WF		
93° 	SDJCR/L 1212 F07	12	12	12	80	15	16	DC... 0702... A265-A268, A311 DC... 11T3...	
	1616 H07	16	16	16	100	15	20		
	2020 K07	20	20	20	125	20	25		
	1616 H11	16	16	16	100	24	20		
	2020 K11	20	20	20	125	24	25		
	2525 M11	25	25	25	150	28	32		
93° 	SDJNR/L 1616 H11	16	16	16	100	25	20	DN... 1104... A234-A235, A237	
	2020 K11	20	20	20	125	25	25		
	2525 M11	25	25	25	150	25	32		

Spare parts

Designation	Screw	Shim	Shim screw	Wrench				
...07	SO 25065I	-	-	T 7				
...11	SO 35124I	SSD 32	SO 50090S	T 15				
...1104...	SO 35120I	SSD 32	SO 50090S	T 10				

Screw type holders

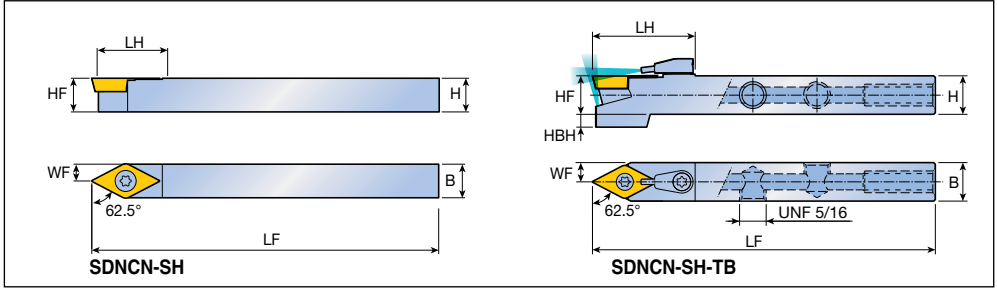

Approach angle	Designation	Dimension (mm)							Insert
		H	HF	HBH	B	LF	LH	WF	
62.5° 	# SDNCN 0808 K07-SH	8	8	-	8	125	15	4	DC... 0702... DC... 11T3... A265-A268, A311
	1010 K07-SH	10	10	-	10	125	15	5	
	1010 K11-SH	10	10	-	10	125	22	5	
	1212 K11-SH	12	12	-	12	125	22	6	
	1616 K11-SH	16	16	-	16	125	22	8	
62.5° COOLBURST	# SDNCN 1212 K11-SH-TB	12	12	4	12	125	32	6	
	1616 K11-SH-TB	16	16	-	16	125	32	8	

► #: TOP-MINI holders

Spare parts

Designation	Screw	Cooling unit	Plug	Wrench				
...07	SO 25065I	-	-	T 7	-			
...11-SH	SO 35080I	-	-	T 7	-			
SDNCN-SH-TB	SO 35080I	S-CU-TB	PLG 5/16 UNF	T 15	L-W 5/32			

► Please refer to A135 page for COOL-BURST accessories

Screw type holders

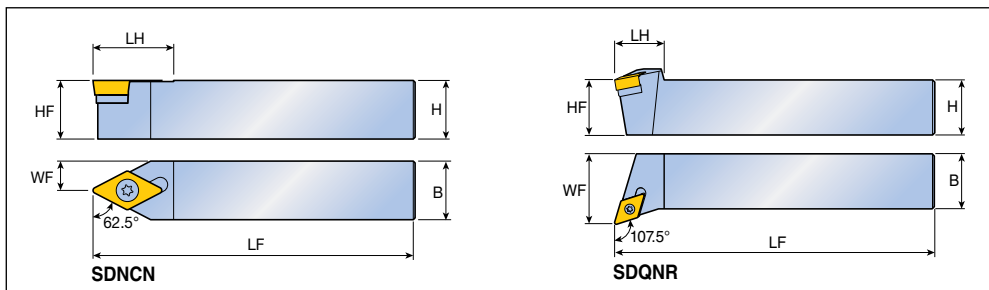

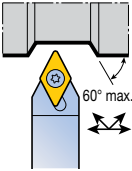
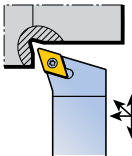
Approach angle	Designation	Dimension (mm)						Insert
		H	HF	B	LF	LH	WF	
62.5° 	SDNCN 0808 F07	8	8	8	80	15	4	DC... 0702... DC... 11T3... A265-A268, A311
	1010 F07	10	10	10	80	15	5	
	1616 H11	16	16	16	100	22	8	
	2525 M11	25	25	25	150	22	12.5	
107.5° 	SDQNR/L 1616 H11	16	16	16	100	22	20	DN... 1104... A234-A235, A237
	2020 K11	20	20	20	125	22	25	
	2525 M11	25	25	25	150	22	32	

Spare parts

Designation	Screw	Shim	Shim screw	Wrench				
...07	SO 25065I	-	-	T 7				
SDNCN ...11	SO 35124I	SSD 32	SO 50090S	T 15				
SDQNR/L...11	SO 35120I	SSD 32	SO 50090S	T 10				

Screw type holders for FCMX high feed inserts

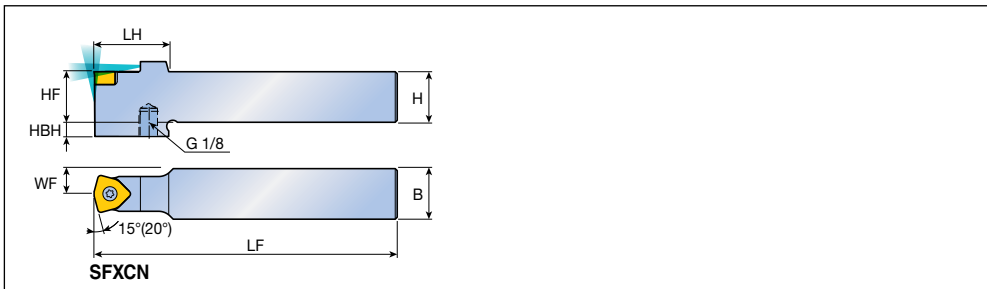

Approach angle	Designation	Dimension (mm)							Insert
		H	HF	B	LF	LH	WF	HBH	
15°	SFXCN 2525 M1006	25	25	25	150	37	12.5	7	FCMX 1006... A270
	3232 P1006	32	32	32	170	37	16	-	
15° FCMX HFG									
20° FCMX HFP									

Spare parts

Designation	Screw	Wrench					
	...1006	SO 45130I	T 20				

Screw type holders

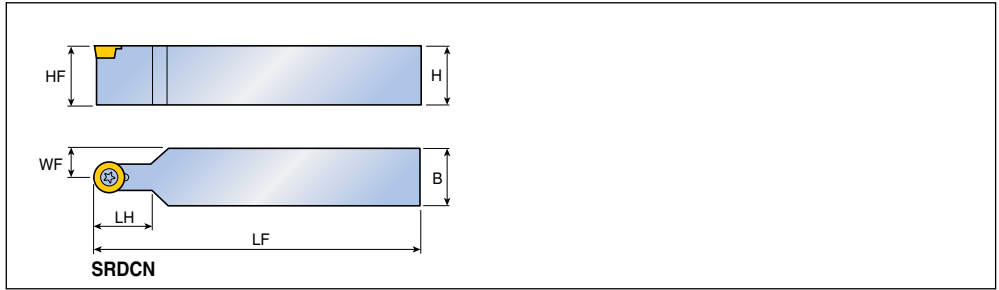

Approach angle	Designation	Dimension (mm)						Insert
		H	HF	B	LF	LH	WF	
45° 	SRDCN 1616 H08	16	16	16	100	20	8	RC...T 0803... A271
	2020 K08	20	20	20	125	25	10	
	2525 M08	25	25	25	150	30	12.5	
	1616 H10	16	16	16	100	16	8	RC...T 10T3...
	2020 K10	20	20	20	125	20	10	
	2525 M10	25	25	25	150	25	12.5	
	2525 M12	25	25	25	150	25	12.5	RC...T 1204...

Spare parts

Designation	Screw	Wrench					
...08	SO 30040I	T 9					
...10	TS 40097I	T 15					
...12	SO 40050I	T 15					

SRGCR/L SRGCR/L-TB



Screw type holders

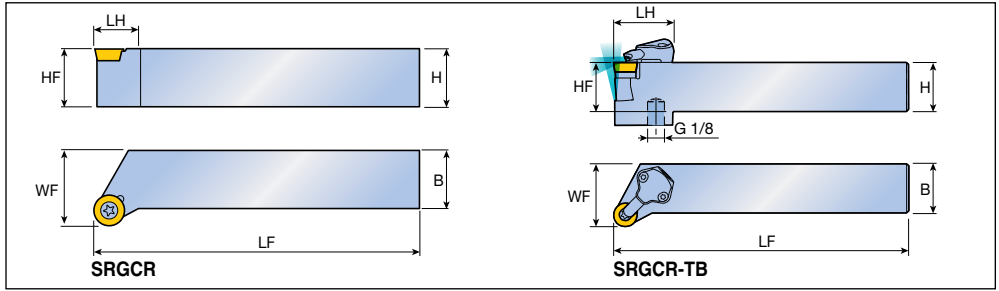

Approach angle	Designation	Dimension (mm)						Insert
		H	HF	B	LF	LH	WF	
90° 	SRGCR/L 1616 H10	16	16	16	100	12.3	20	RC...T 10T3... A271
	2020 K10	20	20	20	125	14	25	
	2525 M10	25	25	25	150	14	32	
90° COOLBURST	SRGCR/L 2525 M12-TB	25	25	25	150	30	32	RC...T 1204...

Spare parts

Designation	Screw	Shim	Shim screw	Cooling unit	O-ring	Wrench	
...10	TS 400971	-	-	-	-	T 15	-
SRGCR/L...TB	TS 35110I	SSR 32	TS 5035062S	CU-R-TB	ID 6.4x0.9	T 8, T 15	L-W 2, L-W 3.5

► Please refer to A135 page for COOL-BURST accessories

Screw type holders

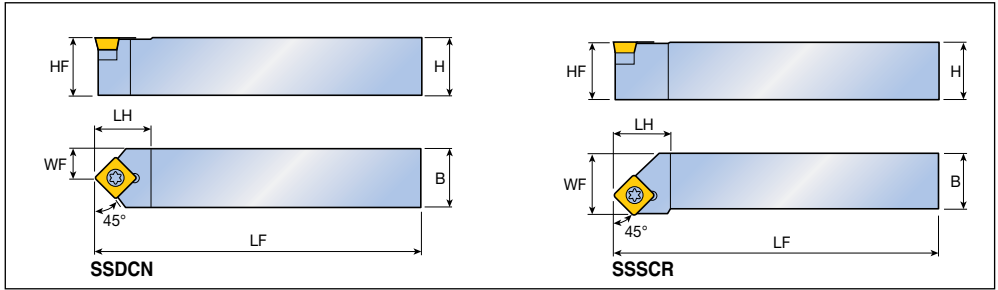

Approach angle	Designation	Dimension (mm)						Insert
		H	HF	B	LF	LH	WF	
45° 	SSDCN 1212 F09	12	12	12	80	15.5	6	SC... 09T3... A271, A312
	1616 H09	16	16	16	100	15.5	8	
45° 	SSSCR/L 1212 F09	12	12	12	80	15.5	14	SC... 09T3...
	1616 H09	16	16	16	100	15.5	17	
	2020 K12	20	20	20	125	24	22	SC... 1204...
	2525 M12	25	25	25	150	24	27	

Spare parts

Designation	Screw	Shim	Shim screw	Wrench				
...F09	SO 35080I	-	-	T 15				
...H09	SO 35124I	SSS 32	SO 50090S	T 15				
...12	SO 45130I	SSS 43N	SO 60105S	T 20				

Screw type holders

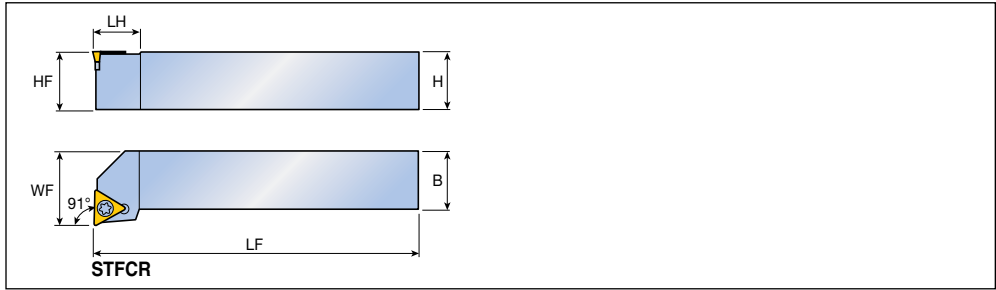

Approach angle	Designation	Dimension (mm)						Insert
		H	HF	B	LF	LH	WF	
91°	STFCR/L 1212 F1102	12	12	12	80	14	16	TC...T 1102...
	1616 H16	16	16	16	100	19	20	TC... 16T3...
	2020 K16	20	20	20	125	19	25	A275, A276, A313, A314
	2525 M16	25	25	25	150	20	32	

Spare parts

Designation	Screw	Shim	Shim screw	Wrench				
...1102	SO 25065I	-	-	T 7				
...16	SO 35124I	SST 32	SO 50090S	T 15				

Screw type holders

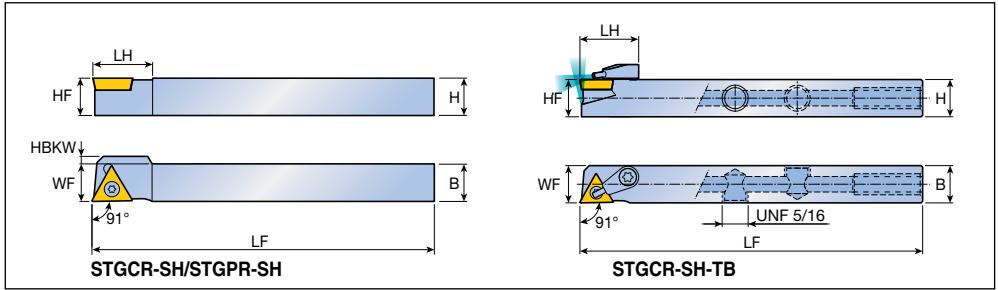

Approach angle	Designation	Dimension (mm)							Insert
		H	HF	B	LF	LH	WF	HBKW	
	# STGCR/L 0808 E08-SH	8	8	8	70	11	8	2	TC...T 0802... A275, A313, A314
	1010 F08-SH	10	10	10	80	11	10	-	
	# STGCR 1010 K11-SH	10	10	10	125	16	10	2	TC...T 1103... A277-A279
	1212 K11-SH	12	12	12	125	16	12	-	
	# STGPR/L 1010 K11-SH	10	10	10	125	16	10	2	TP...T 1103... A277-A279
	1212 K11-SH	12	12	12	125	16	12	-	
1616 K11-SH	16	16	16	125	16	16	-		
	# STGCR 1212 K11-SH-TB	12	12	12	125	20	12	-	TC...T 1103... A275
	1616 K11-SH-TB	16	16	16	125	20	16	-	

- ▶ #: TOP-MINI holders
- ▶ Only -FF/-GF inserts available for 11 size holders

Spare parts

Designation	Screw	Cooling unit	Plug	Wrench			
...08-SH	TS 20043I/HG-P	-	-	T 6P	-		
...11	SO 25065I	-	-	T 7	-		
STGCR/L-SH-TB	SO 25065I	S-CU-TB	PLG 5/16 UNF	T 7	L-W 5/32		

- ▶ Please refer to A135 page for COOL-BURST accessories

Screw type holders

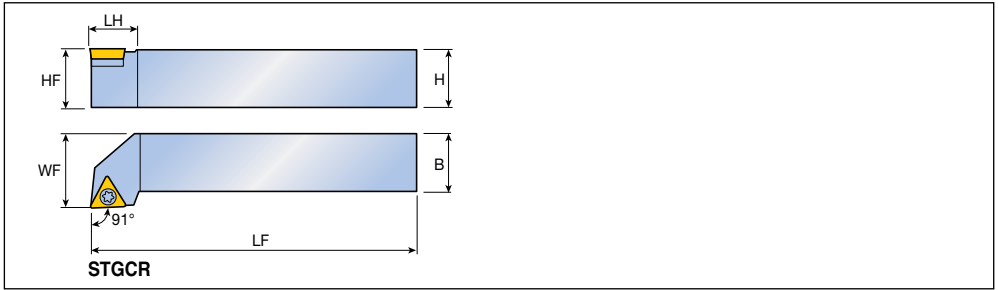

Approach angle	Designation	Dimension (mm)						Insert
		H	HF	B	LF	LH	WF	
91°	STGCR/L 0808 E08	8	8	8	70	10	10	TC...T 0802...
	1010 F08	10	10	10	80	10	12	A275, A276,
	1010 E09	10	10	10	70	11	12	TC...T 0902... A313, A314
	1212 F1102	12	12	12	80	14.3	16	TC...T 1102...
	1616 H1102	16	16	16	100	14.3	20	
	1616 H16	16	16	16	100	21	20	TC...T 16T3...
	2020 K16	20	20	20	125	21	25	
	2525 M16	25	25	25	150	21	32	

Spare parts

Designation	Screw	Shim	Shim screw	Wrench			
...08	TS 20043I/HG-P	-	-	T 6P			
...09	SO 22050I	-	-	T 7			
...1102	SO 25065I	-	-	T 7			
...16	SO 35124I	SST 32	SO 50090S	T 15			

SVJBR/L-SH SVJBR/L-SH-TB



Screw type holders

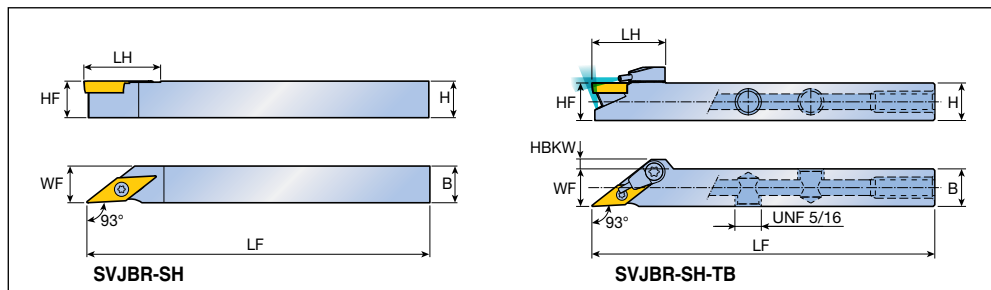

Approach angle	Designation	Dimension (mm)							Insert
		H	HF	B	LF	LH	WF	HBKW	
93° 	# SVJBR/L 1010 K11-SH	10	10	10	125	21	10	-	VB... 1103... A281, A282, A315
	1212 K11-SH	12	12	12	125	21	12	-	
	1616 K11-SH	16	16	16	125	21	16	-	
93° 	# SVJBR/L 1212 K11-SH-TB	12	12	12	125	23.6	12	3	
	1616 K11-SH-TB	16	16	16	125	23.6	16	-	

► #: TOP-MINI holders

Spare parts

Designation	Screw	Cooling unit	Plug	Wrench			
...11	SO 25065I	-	-	T 7	-		
SVJBR/L-SH-TB	SO 25065I	S-CU-TB	PLG 5/16 UNF	T 7	L-W 5/32		

► Please refer to A135 page for COOL-BURST accessories

SVJBR/L SVJBR/L-TB



Screw type holders

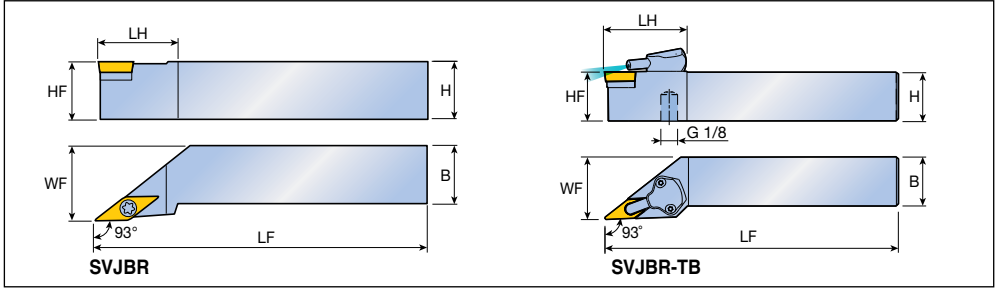

Approach angle	Designation	Dimension (mm)						Insert
		H	HF	B	LF	LH	WF	
93° 	SVJBR/L 2020 K16	20	20	20	125	35	25	VB... 1604... A281, A282, A315
	2525 M16	25	25	25	150	35	32	
	3225 P16	32	32	25	170	35	32	
	3232 P16	32	32	32	170	35	40	
93° COOLBURST	SVJBR/L 2525 M16-TB	25	25	25	150	42	32	

Spare parts

Designation	Screw	Shim	Shim screw	Cooling unit	O-ring	Wrench	
...16	SO 35124I	SSV 32	SO 50090S	-	-	T 15	-
SVJBR/L-TB	SO 35124I	SSV 32	TS 5035062S	CU-V-TB	ID 6.4x0.9	T 8, T 15	L-W 3.5

► Please refer to A135 page for COOL-BURST accessories

Screw type holders

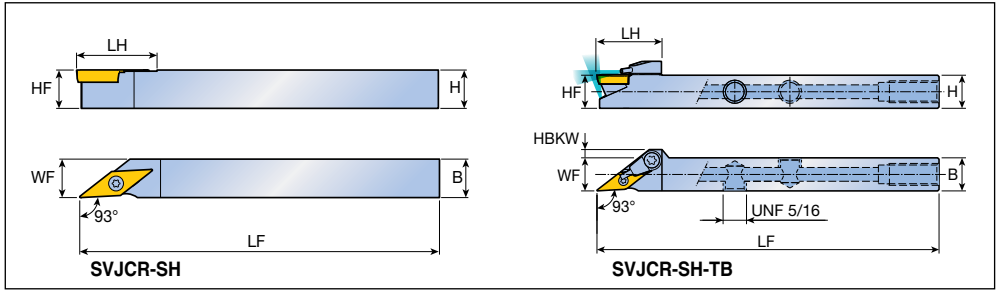

Approach angle	Designation	Dimension (mm)							Inserts
		H	HF	B	LF	LH	WF	HBKW	
93° 	# SVJCR/L 1010 K11-SH	10	10	10	125	21	10	-	VC... 1103... A283, A284
	1212 K11-SH	12	12	12	125	21	12	-	
	1616 K11-SH	16	16	16	125	21	16	-	
	2020 K11-SH	20	20	20	125	21	20	-	
93° 	# SVJCR/L 1212 K11-SH-TB	12	12	12	125	23.6	12	3	
	1616 K11-SH-TB	16	16	16	125	23.6	16	-	
	2020 K11-SH-TB	20	20	20	125	23.6	20	-	

► #: TOP-MINI holders

Spare parts

Designation	Screw	Cooling unit	Plug	Wrench			
...11-SH	SO 25065I	-	-	T 7	-		
SVJCR/L-SH-TB	SO 25065I	S-CU-TB	PLG 5/16 UNF	T 7	L-W 5/32		

► Please refer to A135 page for COOL-BURST accessories

Screw type holders

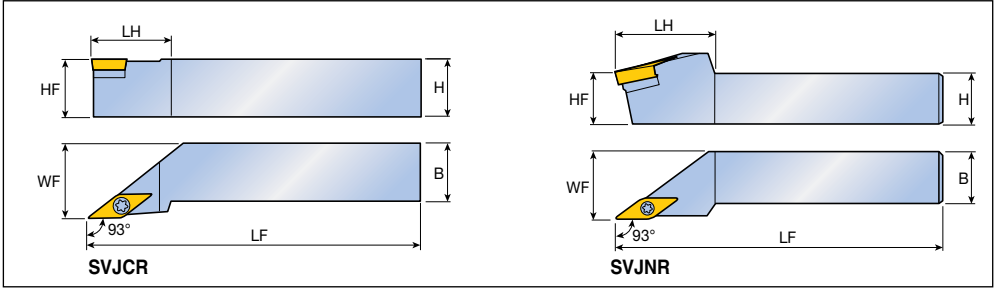

Approach angle	Designation	Dimension (mm)						Inserts
		H	HF	B	LF	LH	WF	
93° 	SVJCR/L 2020 K16	20	20	20	125	35	25	VC... 1604... A283, A284
	2525 M16	25	25	25	150	35	32	
	3225 P16	32	32	25	170	35	32	
	3232 P16	32	32	32	170	47	40	
93° 	SVJNR/L 1616 H13	16	16	16	100	30	20	VN... 1304... A251-A252
	2020 K13	20	20	20	125	35	25	
	2525 M13	25	25	25	150	43	32	

Spare parts

Designation	Screw	Shim	Shim screw	Wrench	
...13	SO 35120I	SSVN 2.522	TS 5035062S	T 10	L-W 3.5
...16	SO 35124I	SSV 32	SO 50090S	T 15	L-W 3.5

Screw type holders

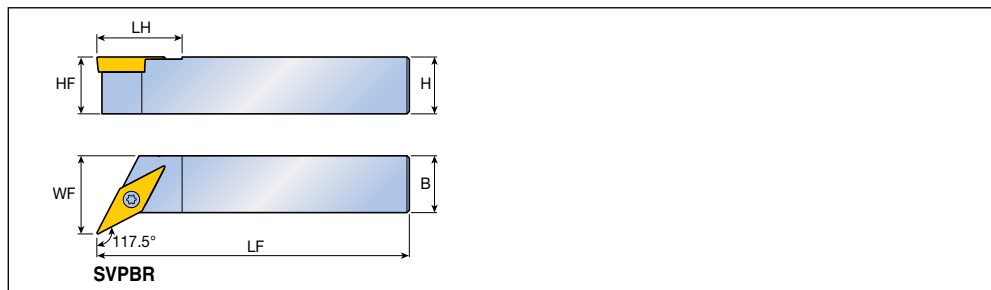





Approach angle	Designation	Dimension (mm)						Insert	
		H	HF	B	LF	LH	WF		
117.5° 	SVPBR/L 1010 E11	10	10	10	70	18	14.5	VB... 1103... A281, A282, A315	
	1212 F11	12	12	12	80	18	16.5		
	1616 F11	16	16	16	80	18	20.5		
	2020 K11	20	20	20	125	18	25		
	2525 M11	25	25	25	150	18	32		
	2020 K16	20	20	20	125	25	25		VB... 1604...
	2525 M16	25	25	25	150	25	32		

Spare parts

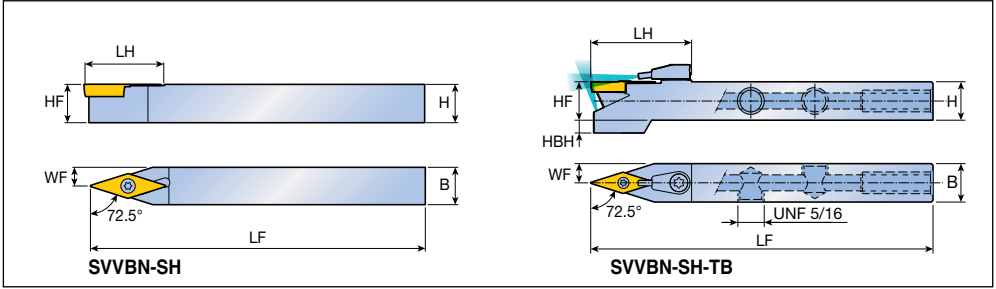
Designation	Screw	Shim	Shim screw	Wrench			
...11	SO 25065I	-	-	T 7	-		
...16	SO 35124I	SSV 32	SO 50090S	T 15	L-W 3.5		

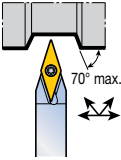

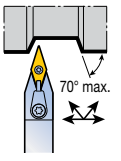

Screw type holders



Approach angle	Designation	Dimension (mm)							Insert
		H	HF	HBH	B	LF	LH	WF	
72.5° 	# SVVBN 1010 K11-SH	10	10	-	10	125	22	5	VB... 1103...  A281, A282, A315
	1212 K11-SH	12	12	-	12	125	22	6	
	1616 K11-SH	16	16	-	16	125	22	8	
72.5°  	# SVVBN 1212 K11-SH-TB	12	12	2	12	125	31.5	6	
	1616 K11-SH-TB	16	16	-	16	125	31.5	8	

► #: TOP-MINI holders

Spare parts

Designation	Screw	Cooling unit	Plug	Wrench			
							
...11	SO 25065l	-	-	T 7	-		
SVVBN-SH-TB	SO 25065l	S-CU-TB	PLG 5/16 UNF	T 7	L-W 5/32		

► Please refer to A135 page for COOL-BURST accessories

Screw type holders

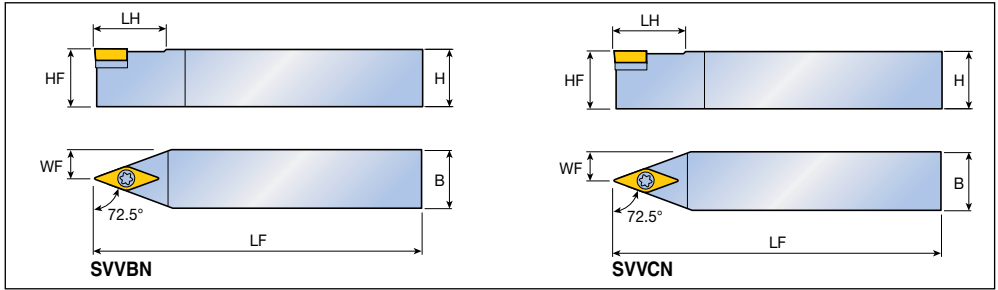

Approach angle	Designation	Dimension (mm)						Insert
		H	HF	B	LF	LH	WF	
72.5° 	SVVBN 2020 K16	20	20	20	125	31.5	10.0	VB... 1604... A281-A282, A315
	2525 M16	25	25	25	150	31.5	12.5	
	3225 P16	32	32	25	170	31.5	12.5	
72.5° 	SVVCN 2020 K16	20	20	20	125	31.5	10.0	VC...T 1604... A283-A284, A315
	2525 M16	25	25	25	150	31.5	12.5	
	3225 P16	32	32	25	170	31.5	12.5	
	3232 P16	32	32	32	170	32	16.0	

Spare parts

Designation	Screw	Shim	Shim screw	Wrench	
...16	SO 35124I	SSV 32	SO 50090S	T 15	L-W 3.5

TMB-SVXCR TMB-SVXCR-TB



Screw type back turning holders

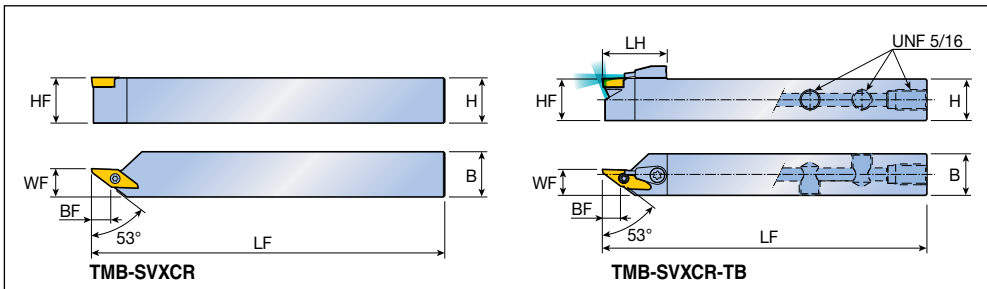

Approach angle	Designation	Dimension (mm)							Insert
		H	HF	B	LF	LH	WF	BF	
53°	# TMB-SVXCR 1212 K11	12	12	12	125	-	10	7.2	BTVC 1103... A259
	1616 K11	16	16	16	125	-	10	7.2	
53°	# TMB-SVXCR 1212 K11-TB	12	12	12	125	25	10	7.2	COOLBURST
	1616 K11-TB	16	16	16	125	25	10	7.2	

► #: TOP-MINI holders

Spare parts

Designation	Screw	Cooling unit	Plug	Wrench	
TMB-SVXCR	SO 250651	-	-	T 7	-
TMB-SVXCR-TB	SO 250651	S-CU-TB	PLG 5/16 UNF	T 7	L-W 5/32

► Please refer to A135 page for COOL-BURST accessories

LVJBR/L LVJBR-SH





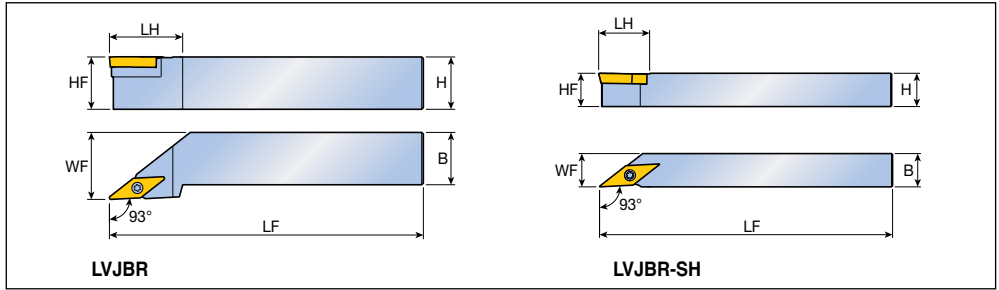

Screw type holders



Approach angle	Designation	Dimension (mm)						Insert
		H	HF	B	LF	LH	WF	
93°	LVJBR/L 2020 K16	20	20	20	125	35	25	VBMX 1604...  A282
	2525 M16	25	25	25	150	35	32	
93°	LVJBR 1616 K16-SH	16	16	16	125	24.5	16	

Spare parts

Designation	Screw	Shim	Shim screw	Wrench	
					
LVJBR/L	SO 35124I	SSVX 32	TS 5035062S	T 15	L-W 3.5
LVJBR-SH	SO 35080I	-	-	T 15	-

Screw type holders

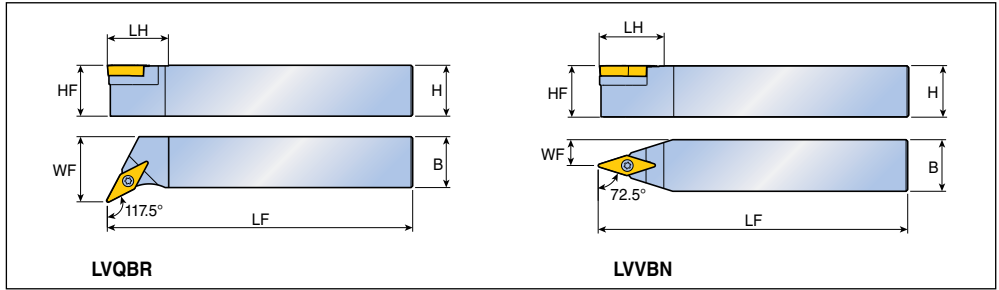

Approach angle	Designation	Dimension (mm)						Insert
		H	HF	B	LF	LH	WF	
117.5°	LVQBR/L 2525 M16	25	25	25	150	30	32	VBMX 1604... A282
72.5°	LVVBN 2525 M16	25	25	25	150	31.5	12.5	

Spare parts

Designation	Screw	Shim	Shim screw	Wrench	
LVQBR/L	SO 35124I	SSVX 32	TS 5035062S	T 15	L-W 3.5
LVVBN	SO 35124I	SSVX 32	TS 5035062S	T 15	L-W 3.5

Sleeve holders

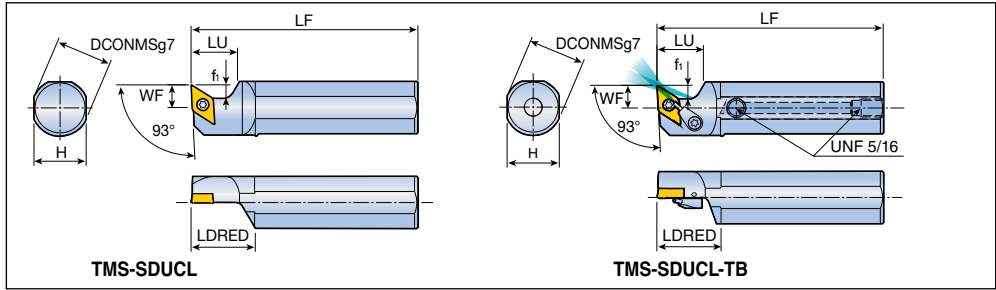

Approach angle	Designation	Dimension (mm)							Insert
		DCONMS	H	LF	f ₁	LU	LDRED	WF	
93° 	# TMS-16X SDUCL 11	16	15	85	6	20	28	10	DC... 11T3... A265-A268, A311
	19.05H SDUCL 11	19.05	17	100	6	20	28	10	
	20H SDUCL 11	20	18	100	6	20	28	10	
	22H SDUCL 11	22	20	100	6	20	28	10	
	25H SDUCL 11	25	23	100	6	20	28	10	
93° 	# TMS-16X SDUCR 11-TB	16	15	85	6	20	28	10	
	19.05H SDUCL 11-TB	19.05	17	100	6	20	28	10	
	20H SDUCL 11-TB	20	18	100	6	20	28	10	
	22H SDUCL 11-TB	22	20	100	6	20	28	10	
	25H SDUCL 11-TB	25	23	100	6	20	28	10	

► #: TOP-MINI holders

Spare parts

Designation	Screw	Cooling unit	Plug	Wrench	
TMS-SDUCL	SO 35080I	-	-	T 15	-
TMS-SDUCL-TB	SO 35080I	S-CU-TB	PLG 5/16 UNF	T 15	L-W 5/32

► Please refer to A135 page for COOL-BURST accessories

Sleeve holders

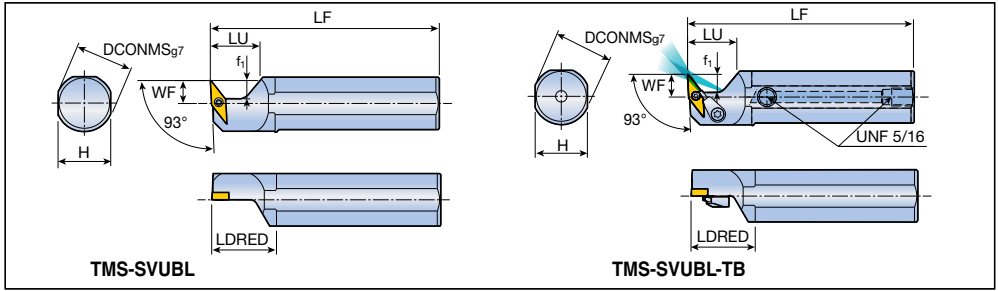

Approach angle	Designation	Dimension (mm)							Insert
		DCONMS	H	LF	f ₁	LU	LDRED	WF	
 93°	# TMS-19.05H SVUBL 11	19.05	17	100	8	21	25	10	VB... 1103...
	20H SVUBL 11	20	18	100	8	21	25	10	
	22H SVUBL 11	22	20	100	8	21	25	10	
	25H SVUBL 11	25	23	100	8	21	28	10	
	# TMS-19.05H SVUCL 11	19.05	17	100	8	21	25	10	VC... 1103...
	22H SVUCL 11	22	20	100	8	21	25	10	
	25.4H SVUCL 11	25	23	100	8	21	28	10	
	25H SVUCL 11	25	23	100	8	21	28	10	
 93°	# TMS-16X SVUBR 11-TB	16	15	85	8	21	25	10	VB... 1103...
	19.05H SVUBL 11-TB	19.05	17	100	8	21	25	10	
	20H SVUBL 11-TB	20	18	100	8	21	25	10	
	22H SVUBL 11-TB	22	20	100	8	21	25	10	
	25H SVUBL 11-TB	25	23	100	8	21	28	10	

► #: TOP-MINI holders





Spare parts

Designation	Screw	Cooling unit	Plug	Wrench	
TMS-SVUBL	SO 25065I	-	-	T 7	-
TMS-SVUBR/L-TB	SO 25065I	S-CU-TB	PLG 5/16 UNF	T 7	L-W 5/32

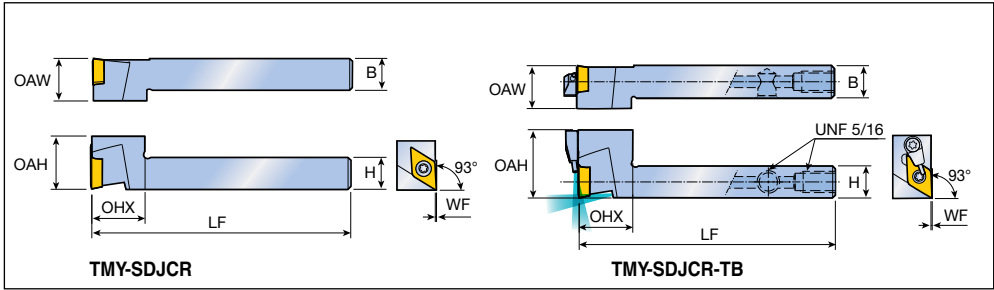
► Please refer to A135 page for COOL-BURST accessories

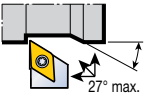



Y-axis holders



Approach angle	Designation	Dimension (mm)							Insert
		H	B	LF	OHX	OAH	OAW	WF	
93° 	# TMY-SDJCR 1212 K11	12	12	125	21	20	16	0	DC... 11T3...  A265-A268, A311
	SDJCR 1616 K11	16	16	125	21	20	16	0	
93°  	# TMY-SDJCR 1212 K11-TB	12	12	125	21	25.5	16	0	
	SDJCR 1616 K11-TB	16	16	125	21	25.5	16	0	

► #: TOP-MINI holders

Spare parts

Designation	Screw	Cooling unit	Plug	Wrench	
					
TMY-SDJCR	SO 35080I	-	-	T 15	-
TMY-SDJCR-TB	SO 35080I	S-CU-TB	PLG 5/16 UNF	T 15	L-W 5/32

► Please refer to A135 page for COOL-BURST accessories

Y-axis holders

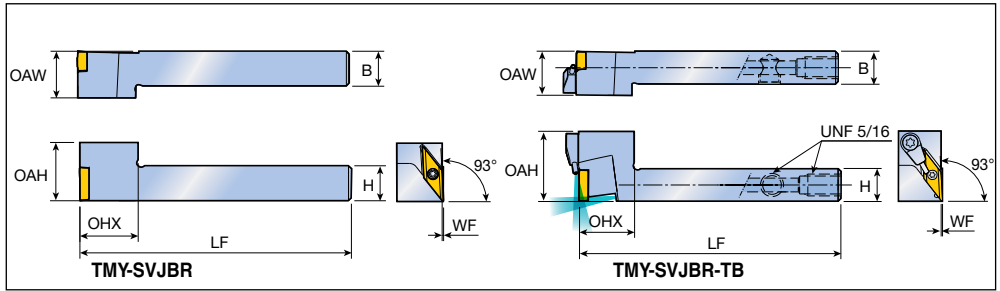

Approach angle	Designation	Dimension (mm)							Insert	
		H	B	LF	OHX	OAH	OAW	WF		
93° 47° max. 	# TMY-SVJBR 1212 K11	12	12	125	20	20	16	0	VB... 1103... A281-A282, A315	
	SVJBR 1616 K11	16	16	125	20	20	16	0		
93° 47° max. COOL-BURST 	# TMY-SVJBR 1212 K11-TB	12	12	125	20	25.5	16	0		
	SVJBR 1616 K11-TB	16	16	125	20	25.5	16	0		

► #: TOP-MINI holders

Spare parts

Designation	Screw	Cooling unit	Plug	Wrench	
TMY-SVJBR	SO 25065I	-	-	T 7	-
TMY-SVJBR-TB	SO 25065I	S-CU-TB	PLG 5/16 UNF	T 7	L-W 5/32

► Please refer to A135 page for COOL-BURST accessories

Shift holders

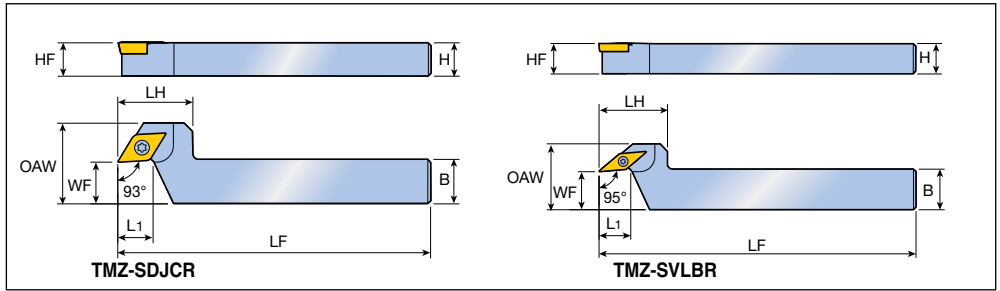

Approach angle	Designation	Dimension (mm)								Insert
		H	HF	B	LF	L1	OAW	LH	WF	
93° 	# TMZ-SDJCR 1216 K11-F15	12	12	16	125	12.5	29	27	15	DC... 11T3... A265-A268, A311
	SDJCR 1620 K11-F15	16	16	20	125	16.3	29	30	15	
95° 	# TMZ-SVLBR 1216 K11-F15	12	12	16	125	12.3	26	27	15	VB... 1103... A218-A282, A315
	SVLBR 1620 K11-F15	16	16	20	125	16.2	26	30	15	

► #: TOP-MINI holders

Spare parts

Designation	Screw	Wrench				
TMZ-SDJCR	SO 35080I	T 15				
TMZ-SVLBR	SO 25065I	T 7				

T-holders

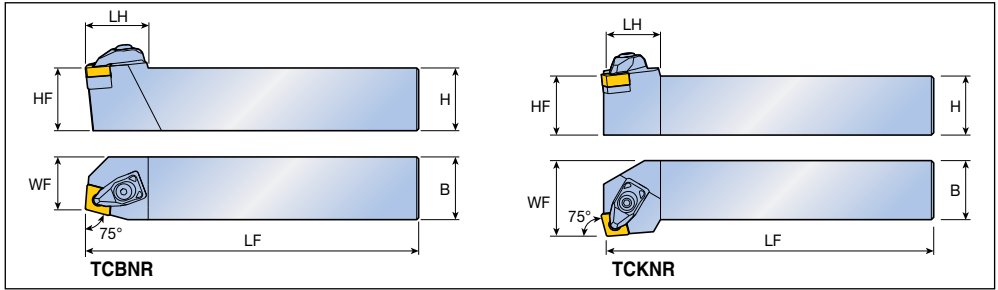

Approach angle	Designation	Dimension (mm)						Insert
		H	HF	B	LF	LH	WF	
75° 	TCBNR/L 2525 M12	25	25	25	150	32	22.5	CN... 1204...
	3232 P19	32	32	32	170	42	27	CN... 1906... A226, A228-A232
75° 	TCKNR/L 2525 M12	25	25	25	150	25	32	CN... 1204...

Spare parts

Designation	Clamp	Clamp screw	Spring	Shim	Shim screw		Wrench	
...12	DLM 4	DLS 4	DSP 4	TSC 44	SO 40050I	-	L-W 3	T 15
...19	DLM 6	DLS 5	DSP 5	LSC 63	-	SO 80180I	L-W 4	-

T-holders

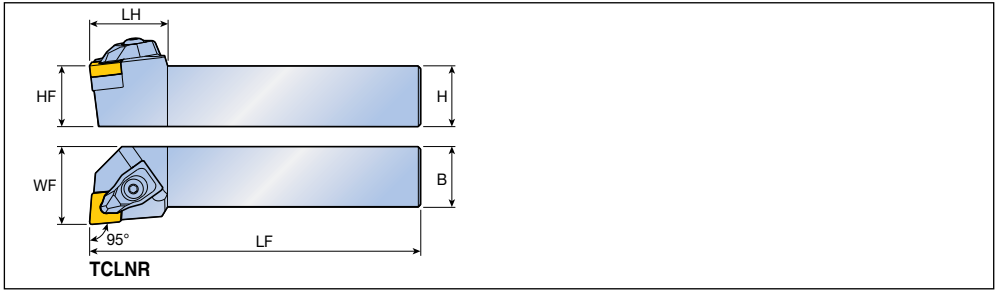

Approach angle	Designation	Dimension (mm)						Insert
		H	HF	B	LF	LH	WF	
95°	TCLNR/L 2020 K12	20	20	20	125	32	25	CN... 1204... A226, A228-A232
	2525 M12	25	25	25	150	32	32	
	3225 P12	32	32	25	170	32	32	
	3232 P12	32	32	32	170	32	40	CN... 1606...
	2525 M16	25	25	25	150	36	32	
	3232 P16	32	32	32	170	36	40	CN... 1906...
	3232 P19	32	32	32	170	42	40	
	4040 S19	40	40	40	250	42	50	

Spare parts





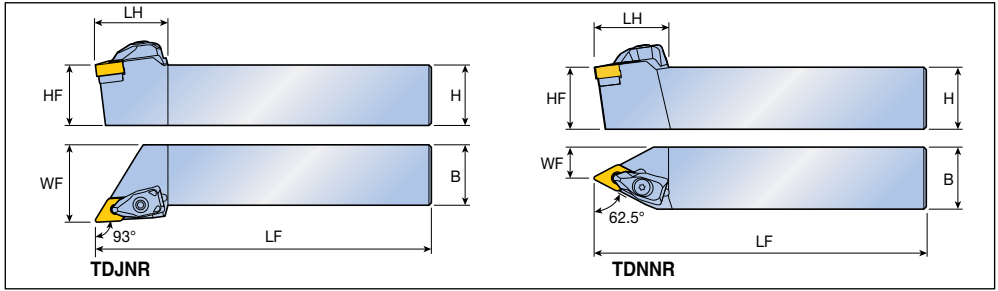

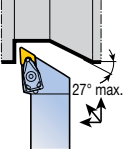
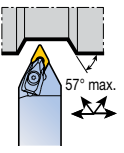

Designation	Clamp	Clamp screw	Spring	Shim	Shim screw		Wrench	
...12	DLM 4	DLS 4	DSP 4	TSC 44	SO 40050I	-	L-W 3	T 15
...16	DLM 5	DLS 5	DSP 5	TSC 54	SO 50090I	-	L-W 4	T 20
...19	DLM 6	DLS 5	DSP 5	LSC 63	-	SO 80180I	L-W 4	-

T-holders



Approach angle	Designation	Dimension (mm)						Insert
		H	HF	B	LF	LH	WF	
93° 	TDJNR/L 2020 K11	20	20	20	125	30	25	DN... 1104...
	2525 M11	25	25	25	150	30	32	DN... 1506... A234-A238
	2020 K15	20	20	20	125	39	25	
	2525 M15	25	25	25	150	39	32	
	3232 P15	32	32	32	170	39	40	
	2020 K1504	20	20	20	125	39	25	DN... 1504...
	2525 M1504	25	25	25	150	39	32	
62.5° 	TDNNR/L 2525 M11	25	25	25	150	30	12.5	DN... 1104...

Spare parts

Designation	Clamp	Clamp screw	Spring	Shim		Shim screw	Wrench	
								
...11	DLM 3	DLS 3	DSP 3	LSD 32	-	SO 40085I	L-W 2.5	T 15
...15	DLM 4	DLS 4	DSP 4	-	TSD 43	SO 40050I	L-W 3	T 15
...1504	DLM 4	DLS 4	DSP 4	-	TSD 44	SO 40050I	L-W 3	T 15

T-holders

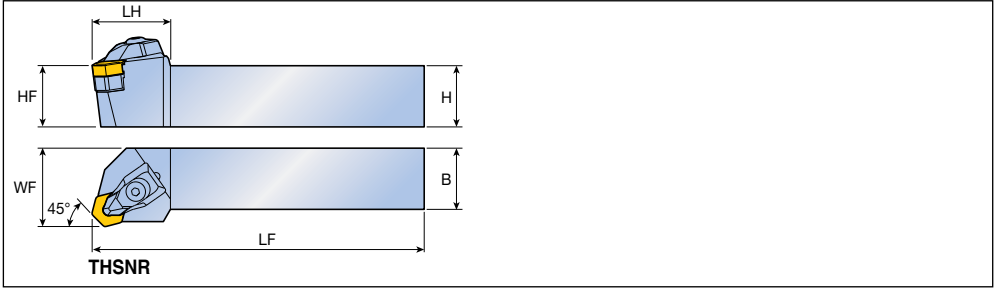

Approach angle	Designation	Dimension (mm)						Insert
		H	HF	B	LF	LH	WF	
45°	THSNR/L 2525 M05	25	25	25	150	32	32	HN... 0504...
	3232 P05	32	32	32	170	32	40	
	2525 M10	25	25	25	150	42	32	HN... 1006...
	3232 P10	32	32	32	170	42	40	

Spare parts

Designation	Clamp	Clamp screw	Spring	Shim	Shim screw	Wrench	
...05	DLM 4	DLS 4	DSP 4	TSH 44	SO 40050I	L-W 3	T 15
...10	DLM 6	DLS 5	DSP 5	TSH 64	SO 50090I	L-W 4	T 20

T-holders

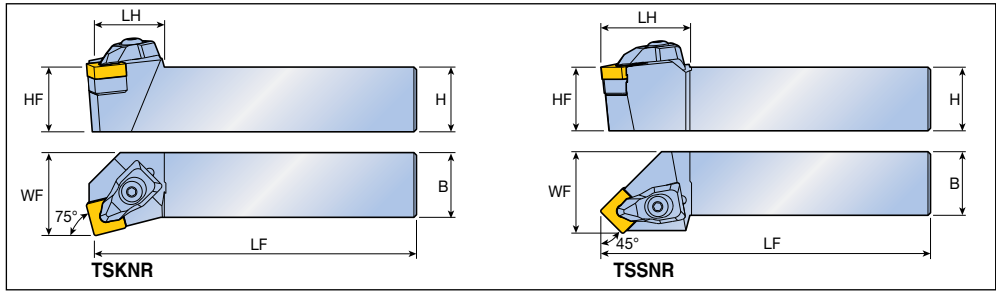

Approach angle	Designation	Dimension (mm)						Insert
		H	HF	B	LF	LH	WF	
75°	TSKNR/L 2525 M12	25	25	25	150	27	32	SN... 1204... A241-A246, A296, A297, A306
45°	TSSNR/L 2525 M12	25	25	25	150	35	32	SN... 1204...

Spare parts

Designation	Clamp	Clamp screw	Spring	Shim	Shim screw	Wrench	
...12	DLM 4	DLS 4	DSP 4	TSS 44	SO 40050I	L-W 3	T 15

TTQNR/L TTQNR/L-TB



T-holders

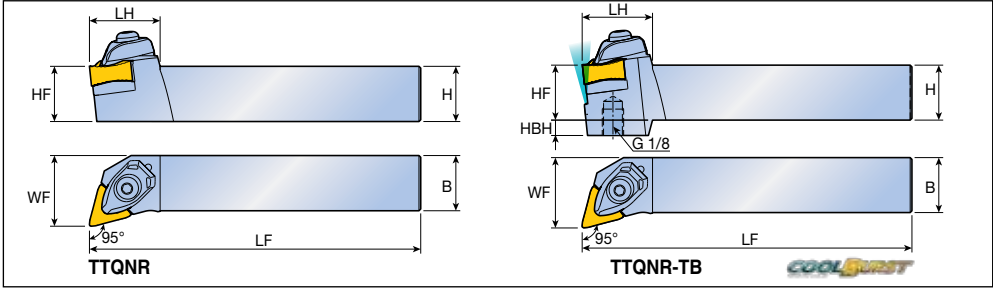

Approach angle	Designation	Dimension (mm)							Insert
		H	HF	B	LF	LH	WF	HBH	
95°	TTQNR/L 2525 M2109	25	25	25	150	32	32	-	TNMV 2109... A256
	3232 P2109	32	32	32	170	32	40	-	
	TTQNR/L 2525 M2109-TB	25	25	25	150	32	32	7	
	3232 P2109-TB	32	32	32	170	32	40	-	

- ▶ BWT: Backward turning
- ▶ FWT: Forward turning



Spare parts

Designation	Clamp	Clamp screw	Spring	Shim	Shim screw	Wrench	
...2109	DLM 4.4T-NV	DLS 5	DSP 5	TSTV 210510	TS 350831/HG	L-W 4	T 10
...2109-TB	DLM 4.4T-NV	DLS 5	DSP 5	TSTV 210510	TS 350831/HG	L-W 4	T 10



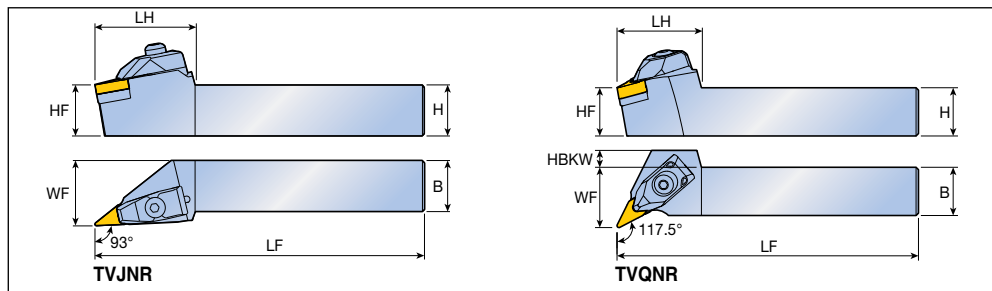

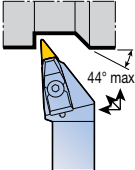

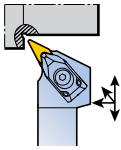







▶ Please refer to A135 page for COOL-BURST accessories

T-holders



Approach angle	Designation	Dimension (mm)							Insert
		H	HF	B	LF	LH	WF		
93° 	TVJNR/L 2020 K13	20	20	20	125	49	25	VN... 1304...  A251-A252	
	2525 M13	25	25	25	150	49	32		
	2020 K16	20	20	20	125	49	25	VN... 1604...  A251-A252, A300, A308	
	2525 M16	25	25	25	150	49	32		
117.5° 	TVQNR/L 2020 K16	20	20	20	125	42	25	VN... 1604...	
	2525 M16	25	25	25	150	42	32		

Spare parts

Designation	Clamp	Clamp screw	Spring	Shim	Shim screw		Wrench	
...13	 DLM 3V	 DLS 5	 DSP 5	 MSV 2.522	 SC 4-SH	-	 L-W 4	 T 15
...16	 DLM 3V	 DLS 5	 DSP 5	 TSV 33	-	 SO 35080I	 L-W 4	 T 15

T-holders

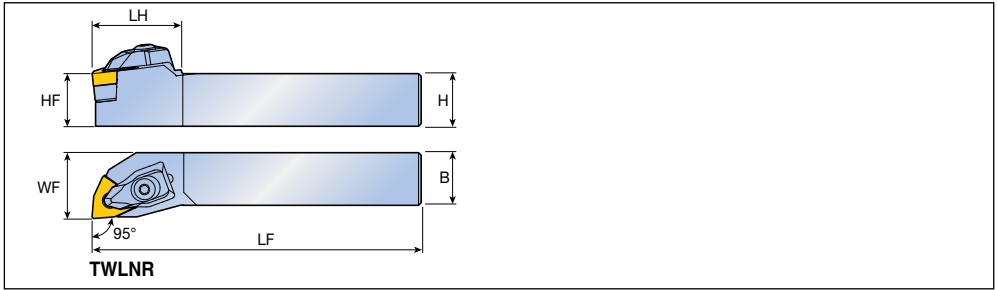

Approach angle	Designation	Dimension (mm)						Insert
		H	HF	B	LF	LH	WF	
95°	TWLNR/L 2020 K06	20	20	20	125	26	25	WN...G 0604...
	2525 M06	25	25	25	150	26	32	A253-A255,
	2020 K08	20	20	20	125	34.2	25	WN... 0804... A300, A309
	2525 M08	25	25	25	150	34.2	32	
	3232 P08	32	32	32	170	34.2	40	

Spare parts

Designation	Clamp	Clamp screw	Spring	Shim	Shim screw	Wrench	
...06	DLM 3	DLS 3	DSP 3	PSW 32	SO 40090I	L-W 2.5	T 15
...08	DLM 4	DLS 4	DSP 4	TSW 44	SO 40050I	L-W 3	T 15

T-holders

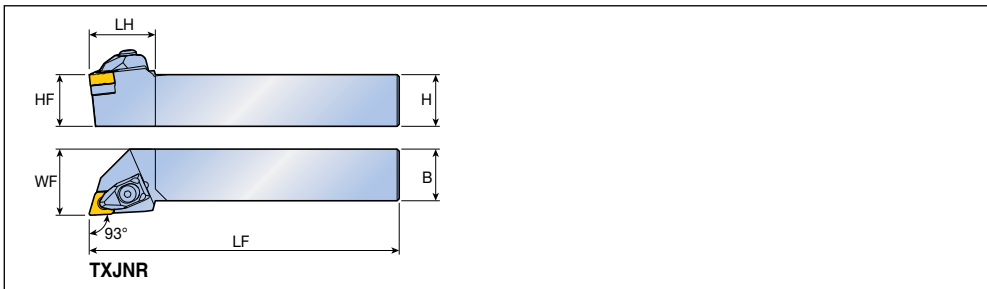

Approach angle	Designation	Dimension (mm)						Insert
		H	HF	B	LF	LH	WF	
93° 	TXJNR/L 2020 K1105	20	20	20	125	32	25	XN... 1105... A257
	2525 M1105	25	25	25	150	32	32	

Spare parts

Designation	Clamp	Clamp screw	Spring	Shim	Shim screw	Wrench	
...1105	DLM 3.5-NX	DLS 4	DSP 4	TSX 3.53	SO 50090I	L-W 3	T 20

T-holders with high pressure coolant

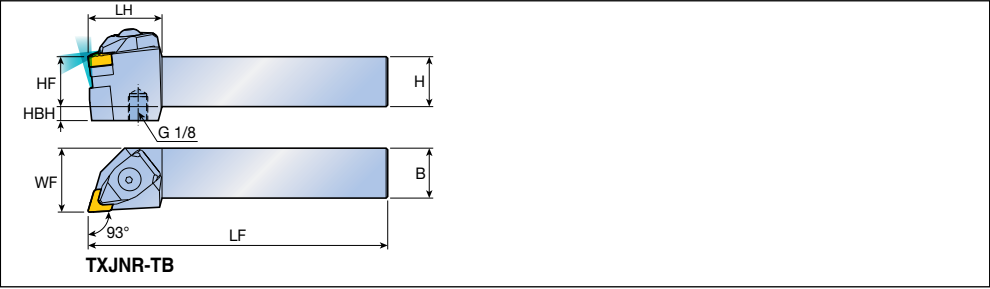

Approach angle	Designation	Dimension (mm)							Insert
		H	HF	B	LF	LH	WF	HBH	
93°	TXJNR/L 2525 M1105-TB	25	25	25	150	37	32	7	XN... 1105...

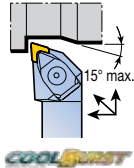

Spare parts

Designation	Clamp	Clamp screw	Spring	Upper O-ring	Lower O-ring	Shim	Shim screw	Wrench	
...1105	DLM 3.5-NX-TB	BH M5x0.8x 21-MO-TB	DSP 4	O-RING ID5.28x 1.78	O-RING ID7.59x 2.62	TSX 3.53	SO 500901	L-W 3	T 20

► Please refer to A135 page for COOL-BURST accessories

T-holders for ZNMV insert

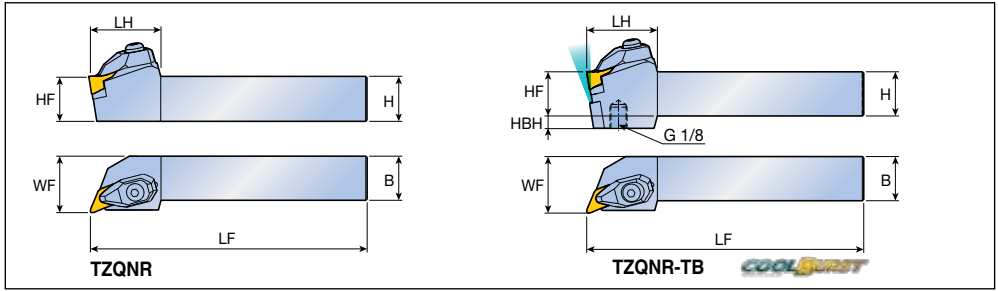

Approach angle	Designation	Dimension (mm)							Insert
		H	HF	B	LF	LH	WF	HBH	
ZNMV 23°(BWT) 95°(FWT)	TZQNR/L 2525 M1410	25	25	25	150	40	32	-	ZNMV 1410... A258
	3232 P1410	32	32	32	170	40	40	-	
 ZNMV Y-BF 28°(BWT) 118°(FWT)	TZQNR/L 2525 M1410-TB	25	25	25	150	40	32	7	
	3232 P1410-TB	32	32	32	170	40	40	-	

- ▶ BWT: Backward turning
- ▶ FWT: Forward turning

Spare parts

Designation	Clamp	Clamp screw	Spring	Shim	Shim screw	Wrench	
...1410	DLM 3.3Z-NV	DLS 5	DSP 5	TSZ 140310	TS 350831/HG	L-W 4	T 10
...1410-TB	DLM 3.3Z-NV	DLS 5	DSP 5	TSZ 140310	TS 350831/HG	L-W 4	T 10



▶ Please refer to A135 page for COOL-BURST accessories

TZXNN TZXNN-TB



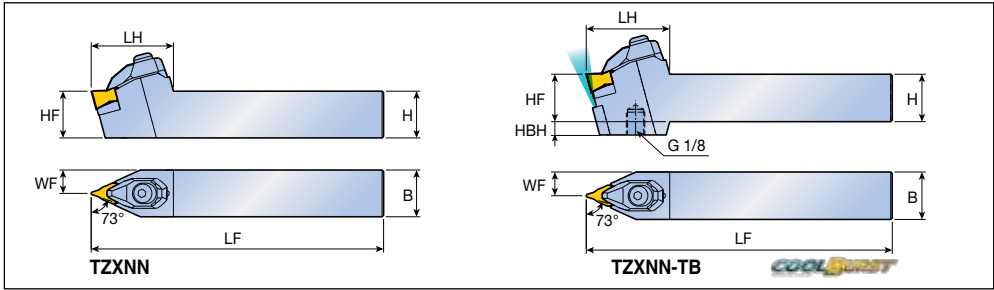

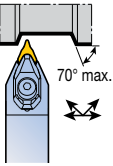

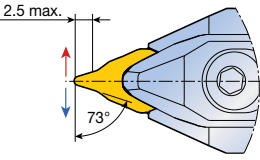

T-holders for ZNMV Y-BF insert



Approach angle	Designation	Dimension (mm)							Insert	
		H	HF	B	LF	LH	WF	HBH		
73° 	TZXNN 2525 M1410	25	25	25	150	44	12.5	-	ZNMV 1410...Y-BF  A258	
	3232 P1410	32	32	32	170	44	16	-		
	TZXNN 2525 M1410-TB	25	25	25	150	44	12.5	7		
	3232 P1410-TB	32	32	32	170	44	16	-		



Spare parts

Designation	Clamp 	Clamp screw 	Spring 	Shim 	Shim screw 	Wrench 	
...1410	DLM 3.3Z-NV	DLS 5	DSP 5	TSZ 140310	TS 35083I/HG	L-W 4	T 10
...1410-TB	DLM 3.3Z-NV	DLS 5	DSP 5	TSZ 140310	TS 35083I/HG	L-W 4	T 10





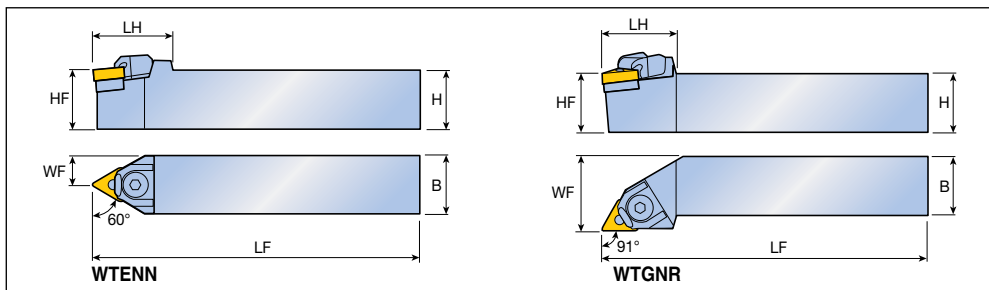

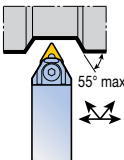
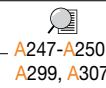
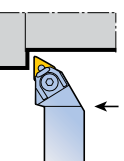





► Please refer to A135 page for COOL-BURST accessories

Wedge clamp type holders



Approach angle	Designation	Dimension (mm)						Insert
		H	HF	B	LF	LH	WF	
60° 	WTENN							
	2020 K16	20	20	20	125	35	10.0	TN... 1604...
	2525 M16	25	25	25	150	35	12.5	TN... 2204... 
	2525 M22	25	25	25	150	38	12.5	
	3225 P22	32	32	25	170	38	12.5	
3232 P22	32	32	32	170	38	16.0		
91° 	WTGNR/L							
	2020 K16	20	20	20	125	32	25	TN... 1604...
	2525 M16	25	25	25	150	32	32	TN... 2204...
	2525 M22	25	25	25	150	38	32	
	3232 P22	32	32	32	170	38	40	

Spare parts

Designation	Wedge clamp	Screw	Snap ring	Shim	Pin screw	Wrench	
...16	 WC 33	 WCS 4	 WSR 4	 WST 33	 WSS 33	 L-W 3, L-W 2.5	
...22	 WC 43	 WCS 4	 WSR 4	 WST 43	 WSS 43	 L-W 3	

Wedge clamp type holders

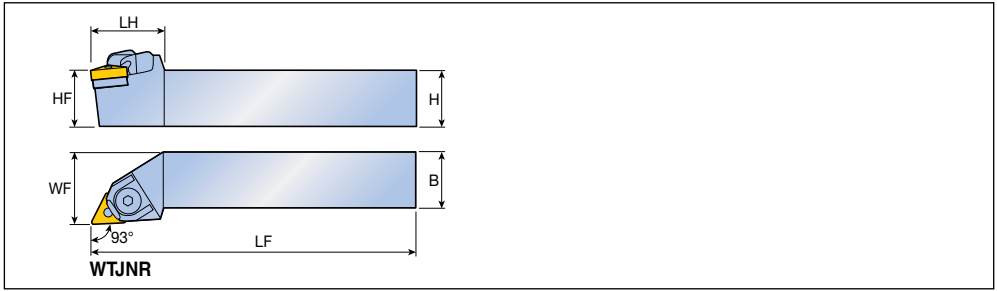

Approach angle	Designation	Dimension (mm)						Insert
		H	HF	B	LF	LH	WF	
93°	WTJNR/L 2020 K16	20	20	20	125	32	25	TN... 1604... A247-A250, A299, A307
	2525 M16	25	25	25	150	32	32	
	3225 P16	32	32	25	170	32	32	
	3232 P16	32	32	32	170	38	40	
	2525 M22	25	25	25	150	38	32	
	3232 P22	32	32	32	170	38	40	
								TN... 2204...

Spare parts

Designation	Wedge clamp	Screw	Snap ring	Shim	Pin screw	Wrench	
...16	WC 33	WCS 4	WSR 4	WST 33	WSS 33	L-W 3, L-W 2.5	
...22	WC 43	WCS 4	WSR 4	WST 43	WSS 43	L-W 3	

Top clamp type holders for V bottom insert

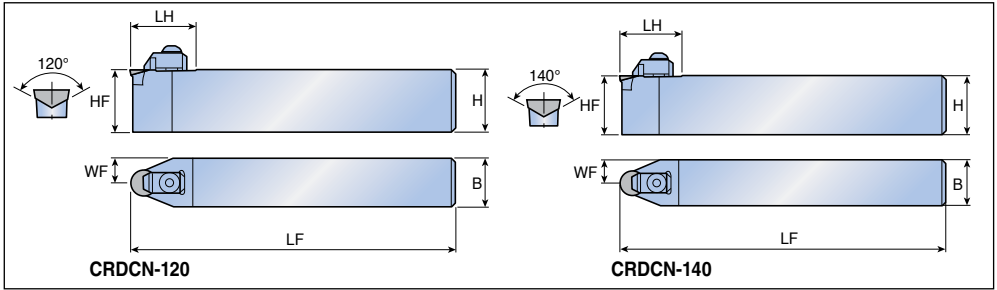

Approach angle	Designation	Dimension (mm)						Insert
		H	HF	B	LF	LH	WF	
45° 	CRDCN 2525 M06-120	25	25	25	150	28	12.5	RCGX 0606...
	3225 P06-120	32	32	25	170	28	12.5	RCGX 0907... RCGX 1207...
	3225 P09-120	32	32	25	170	30	12.5	
	3225 P12-120	32	32	25	170	32	12.5	
	45° 	CRDCN 2525 M06-140	25	25	25	150	28	12.5
3225 P06-140		32	32	25	170	28	12.5	RCGX 0903...FT RCGX 1204...FT
3225 P09-140		32	32	25	170	30	12.5	
3225 P12-140		32	32	25	170	32	12.5	

Spare parts





Designation	Clamp	Clamp screw	Shim	Shim screw		Wrench	
...06-120	BCL 6-20A	BH M6x1x25	CERS 06	SO 22050I	-	L-W 4	T 7
...09-120	BCL 6-20A	BH M6x1x25	CERS 09	-	BH M2.5x0.45x10	L-W 4, L-W 1.5	-
...12-120	BCL 6	BH M6x1x25	CERS 12	-	BH M2.5x0.45x10	L-W 4, L-W 1.5	-
...06-140	BCL 6-20A	BH M6x1x25	CBRS 06	SO 22050I	-	L-W 4	T 7
...09-140	BCL 6-20A	BH M6x1x25	CBRS 09	-	BH M2.5x0.45x10	L-W 4, L-W 1.5	-
...12-140	BCL 6	BH M6x1x25	CBRS 12	-	BH M2.5x0.45x10	L-W 4, L-W 1.5	-

CRDCN-T CRDCR/L-T

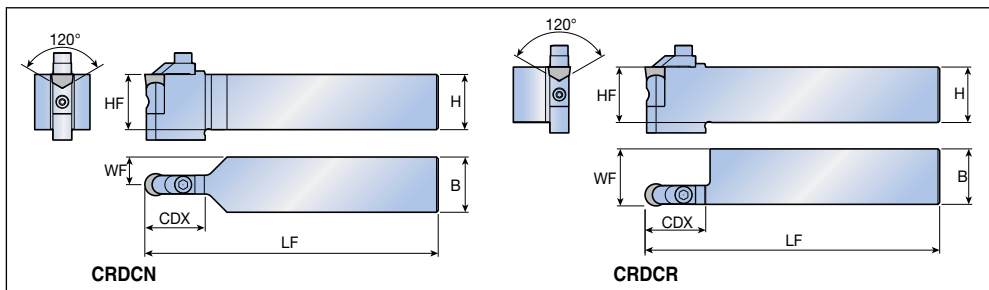

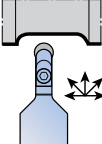

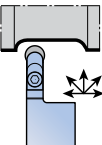



Narrow top clamp type holders for V bottom insert



Approach angle	Designation	Dimension (mm)							Insert
		H	HF	B	LF	CDX	WF		
45° 	CRDCN 3232 P0907-120-T30	32	32	32	170	30	16	RCGX 0907...  RCGX 1207... A301	
	3232 P1207-120-T35	32	32	32	170	35	16		
45° 	CRDCR/L 3232 P0907-120-T30	32	32	32	170	30	32.8	RCGX 0907...  RCGX 1207... A312	
	CRDCR 3225 P0907-120-T30	32	32	25	170	30	32.8		
	CRDCL 3232 P1207-120-T35	32	32	32	170	35	32.9	RCGX 1207...	

Spare parts

Designation	Clamp	Clamp screw	Shim	Shim screw	Wrench	
						
...0907...	HCL 09-M	SH M5X0.8X12	CERS 09-T	SO 35124I	L-W 4	T 15
...1207...	HCL 12-M	SH M6X1X16	CERS 12-T	TS 40140AJ/HG	L-W 5	T 20

Top clamp type holders for V bottom insert

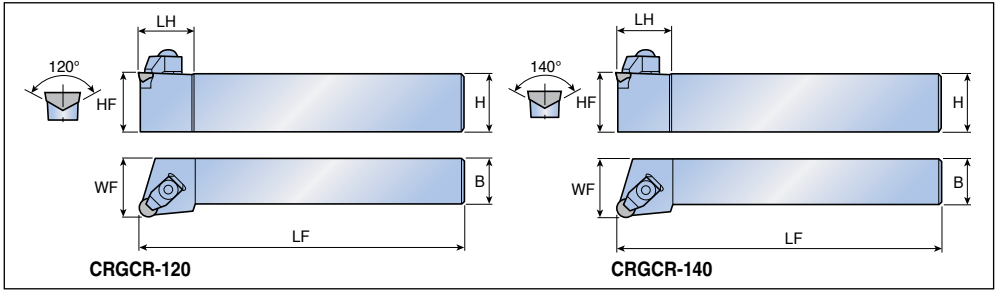

Approach angle	Designation	Dimension (mm)						Insert
		H	HF	B	LF	LH	WF	
90° 	CRGCR/L 2525 M06-120	25	25	25	150	28	32	RCGX 0606...
	3225 P06-120	32	32	25	170	28	32	RCGX 0907... RCGX 1207...
	3225 P09-120	32	32	25	170	30	32	
	3225 P12-120	32	32	25	170	32	32	
90° 	CRGCR/L 3225 P06-140	32	32	25	170	28	32	RCGX 0603...FT
	3225 P09-140	32	32	25	170	30	32	RCGX 0903...FT
	3225 P12-140	32	32	25	170	32	32	RCGX 1204...FT

Spare parts

Designation	Clamp	Clamp screw	Shim	Shim screw		Wrench	
...06...	BCL 6-20A	BH M6x1x25	CERS 06	SO 22050I	-	L-W 4	T 7
...09...	BCL 6-20A	BH M6x1x25	CERS 09	-	BH M2.5x0.45x10	L-W 4, L-W 1.5	-
...12...	BCL 6	BH M6x1x25	CERS 12	-	BH M2.5x0.45x10	L-W 4, L-W 1.5	-

TCBNR/L-CH TCKNR/L-CH





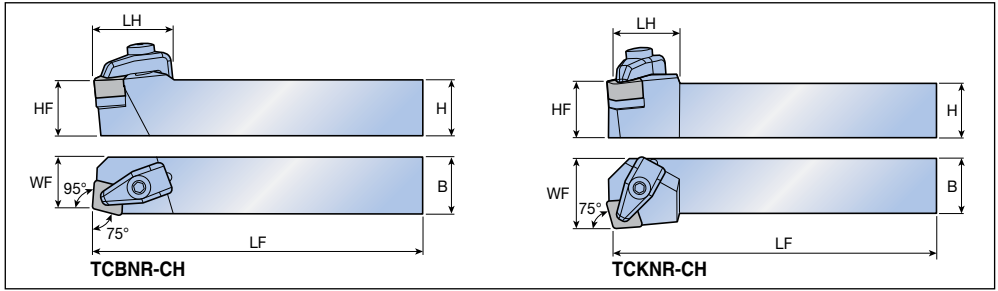



T-holders for CH dimple insert



Approach angle	Designation	Dimension (mm)						Insert
		H	HF	B	LF	LH	WF	
75°	TCBNR/L 2525 M12-CH	25	25	25	150	34.7	23	CNGX 1207...CH  A292
	3225 P12-CH	32	32	25	170	34	24	
75°	TCKNR/L 2525 M12-CH	25	25	25	150	28	32	

Spare parts



Designation	Clamp	Clamp screw	Spring	Shim	Shim screw	Wrench	
...12-CH	 CCL-4	 CSC 4	 DSP 5	 TSC 43	 SO 40050I	 L-W 4	 T 15

TDJNR/L-CH TDNNN-CH



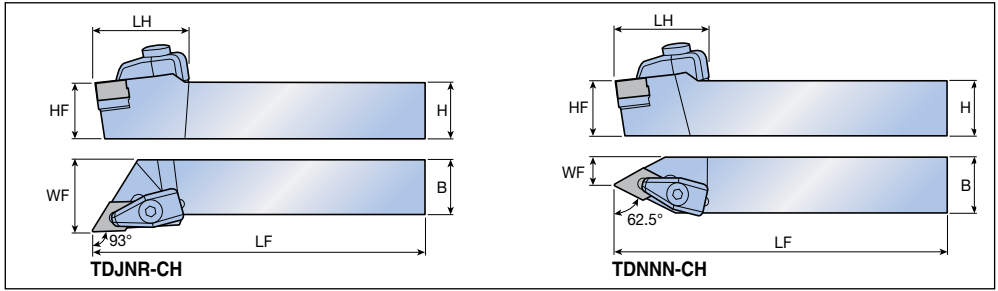

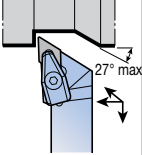

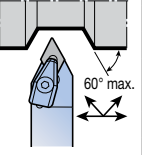

T-holders for CH dimple insert



Approach angle	Designation	Dimension (mm)						Insert
		H	HF	B	LF	LH	WF	
93° 	TDJNR/L 2525 M15-CH	25	25	25	150	38	32	DNGX 1507...CH  A293
	3225 P15-CH	32	32	25	170	38	32	
62.5° 	TDNNN 2525 M15-CH	25	25	25	150	40	12.5	

Spare parts



Designation	Clamp	Clamp screw	Spring	Shim	Shim screw	Wrench	
							
...15-CH	CCL-4	CSC 4	DSP 5	TSD 43	SO 40050I	L-W 4	T 15

TSDNN-DA TSKNR/L-DA

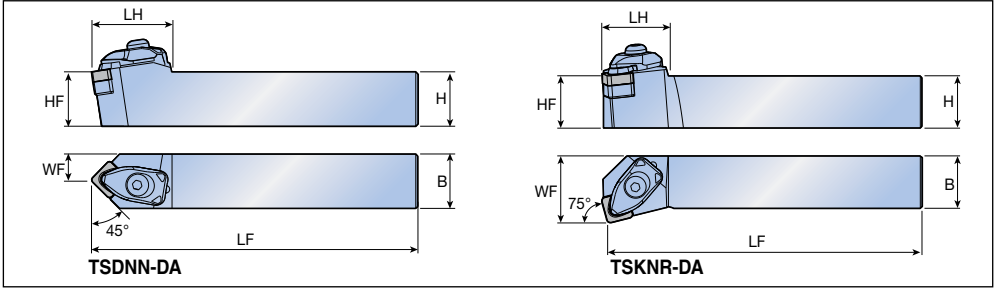

Combi clamp T-holders for DA dimple inserts

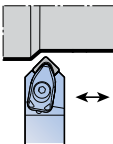

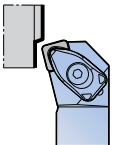
Approach angle	Designation	Dimension (mm)							Insert
		H	HF	B	LF	LH	WF		
45° 	TSDNN <u>2525 M1204-DA</u>	25	25	25	150	37	12.5	SNGX 1204...DA  A306	
75° 	TSKNR/L <u>2525 M1204-DA</u>	25	25	25	150	29	32		

Spare parts

Designation	Clamp	Clamp screw	Spring	Shim	Shim screw	Wrench	
...1204-DA	 DCL S-4DA	 DLS 5	 DSP 5	 TSS 44	 SO 40050I	 L-W 4	 T 15

Combi clamp T-holders for flat inserts

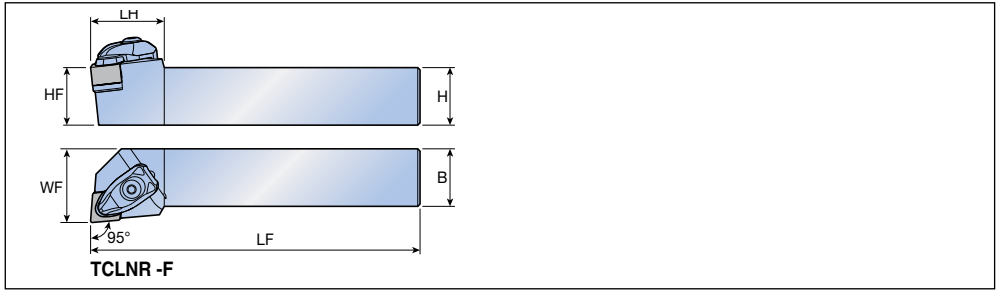

Approach angle	Designation	Dimension (mm)						Insert
		H	HF	B	LF	LH	WF	
95° 	TCLNR/L 2525 M0903-F	25	25	25	150	25	32	CN...N 0903...
	2020 K1204-F	20	20	20	125	32	25	CN...N 1204... A291, A292, A303
	2525 M1204-F	25	25	25	150	32	32	
	2020 K1207-F	20	20	20	125	32	25	CN...N 1207...
	2525 M1207-F	25	25	25	150	32	32	
	3232 P1207-F	32	32	32	170	32	40	

Spare parts



Designation	Clamp	Clamp screw	Spring	Shim	Shim screw	Wrench	
...0903-F	DCL S-3F	DLS 3	DSP 3	LSC 32	SO 40085I	L-W 2.5	T 15
...1204-F	DCL S-4F	DLS 4	DSP 4	TSC 44	SO 40050I	L-W 3	T 15
...1207-F	DCL S-4F	DLS 4	DSP 4	TSC 42	SO 40050I	L-W 3	T 15

TRDNN-F TRGNR/L-F



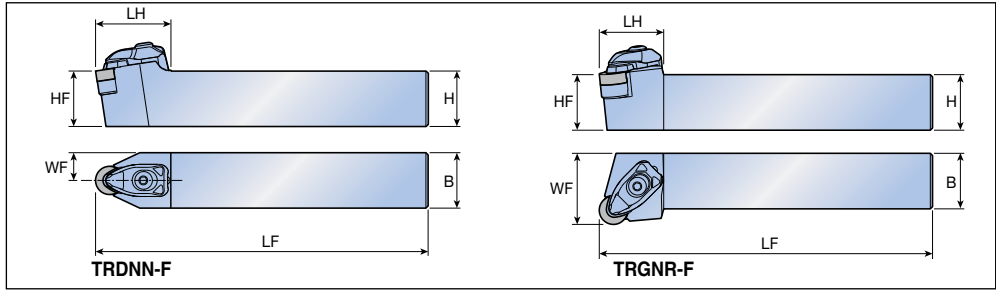

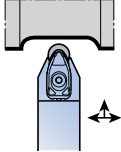

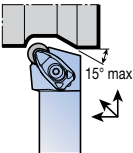















Combi clamp T-holders for flat inserts



Approach angle	Designation	Dimension (mm)						Insert
		H	HF	B	LF	LH	WF	
45° 	TRDNN 2525 M0903-F	25	25	25	150	27	12.5	RN...N 0903... 
	2020 K1204-F	20	20	20	125	34	10	RN...N 1204...  A295, A305
	2525 M1204-F	25	25	25	150	34	12.5	
	2020 K1207-F	20	20	20	125	34	10	RN...N 1207...
	2525 M1207-F	25	25	25	150	34	12.5	
	3225 P1207-F	32	32	25	170	34	12.5	
	3232 P1207-F	32	32	32	170	34	16	
90° 	TRGNR/L 2525 M0903-F	25	25	25	150	29	32	RN...N 0903...
	2020 K1204-F	20	20	20	125	29	25	RN...N 1204...
	2525 M1204-F	25	25	25	150	29	32	
	2020 K1207-F	20	20	20	125	29	25	RN...N 1207...
	2525 M1207-F	25	25	25	150	29	32	
	3225 P1207-F	32	32	25	170	29	32	
	3232 P1207-F	32	32	32	170	29	40	

► RN...N 1204/1207 are exchangeable, RN...N 1203 is not exchangeable on same holder

Spare parts



Designation	Clamp	Clamp screw	Spring	Shim		Shim screw	Wrench	
...0903-F	 DCL S-3F	 DLS 3	 DSP 3	 LSR 32	-	 SO 40085I	 L-W 2.5	 T 15
...1204-F	 DCL S-4F	 DLS 4	 DSP 4	-	 TSR 45	 SO 40050I	 L-W 3	 T 15
...1207-F	 DCL S-4F	 DLS 4	 DSP 4	-	 TSR 43	 SO 40050I	 L-W 3	 T 15

TSDNN-F TSKNR/L-F

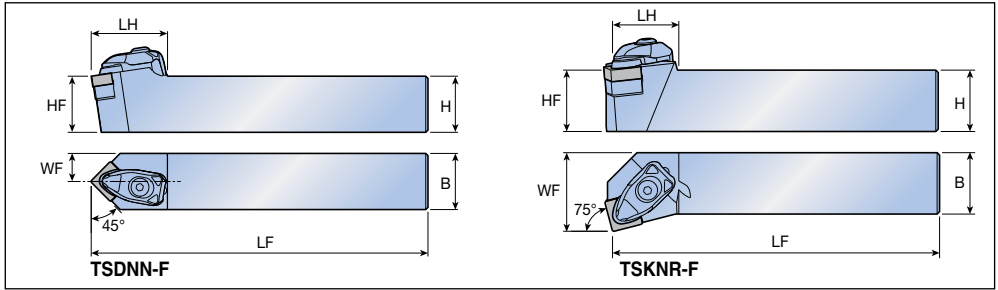

Combi clamp T-holders for flat inserts

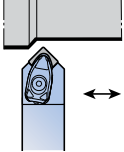

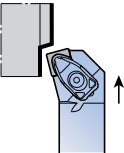
Approach angle	Designation	Dimension (mm)						Insert
		H	HF	B	LF	LH	WF	
45° 	TSDNN 2020 K1204-F	20	20	20	125	34	10	SN...N 1204...
	2525 M1204-F	25	25	25	150	34	12.5	SN...N 1207...  A296, A306
	2525 M1207-F	25	25	25	150	34	12.5	
	3225 P1207-F	32	32	25	170	34	12.5	
	3232 P1207-F	32	32	32	170	34	16	
75° 	TSKNR/L 2525 M1204-F	25	25	25	150	27	32	SN...N 1204...
	3232 P1204-F	32	32	32	170	27	40	SN...N 1207...
	2525 M1207-F	25	25	25	150	27	32	
	3232 P1207-F	32	32	32	170	27	40	

Spare parts

Designation	Clamp	Clamp screw	Spring	Shim	Shim screw	Wrench	
...1204-F	 DCL S-4F	 DLS 4	 DSP 4	 TSS 44	 SO 40050I	 L-W 3	 T 15
...1207-F	DCL S-4F	DLS 4	DSP 4	TSS 42	SO 40050I	L-W 3	T 15

TSRNR/L-F TSSNR/L-F



Combi clamp T-holders for flat inserts

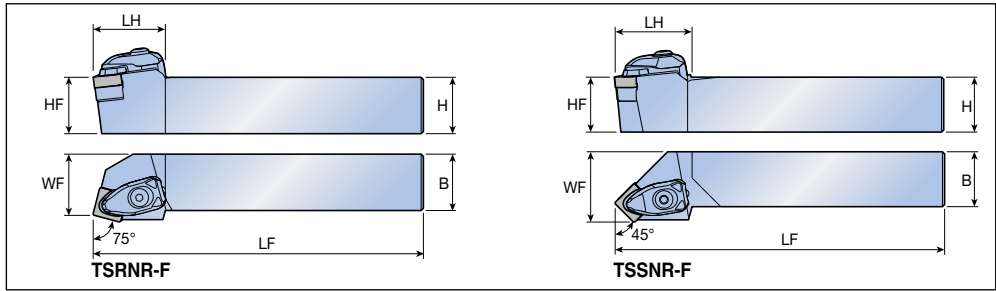

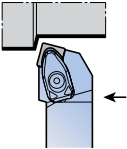
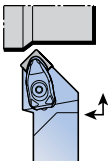
Approach angle	Designation	Dimension (mm)						Insert
		H	HF	B	LF	LH	WF	
75° 	TSRNR/L 2525 M1204-F	25	25	25	150	32	27	SN...N 1204... SN...N 1207... A296, A306
	3232 P1204-F	32	32	32	170	32	35	
	2525 M1207-F	25	25	25	150	32	27	
	3225 P1207-F	32	32	25	170	32	27	
	3232 P1207-F	32	32	32	170	32	35	
45° 	TSSNR/L 2525 M1204-F	25	25	25	150	35	32	SN...N 1204... SN...N 1207...
	3232 P1204-F	32	32	32	170	35	40	
	2525 M1207-F	25	25	25	150	35	32	
	3232 P1207-F	32	32	32	170	35	40	

Spare parts

Designation	Clamp	Clamp screw	Spring	Shim	Shim screw	Wrench	
...1204-F	 DCL S-4F	 DLS 4	 DSP 4	 TSS 44	 SO 40050I	 L-W 3	 T 15
...1207-F	 DCL S-4F	 DLS 4	 DSP 4	 TSS 42	 SO 40050I	 L-W 3	 T 15

Combi clamp T-holders for flat inserts

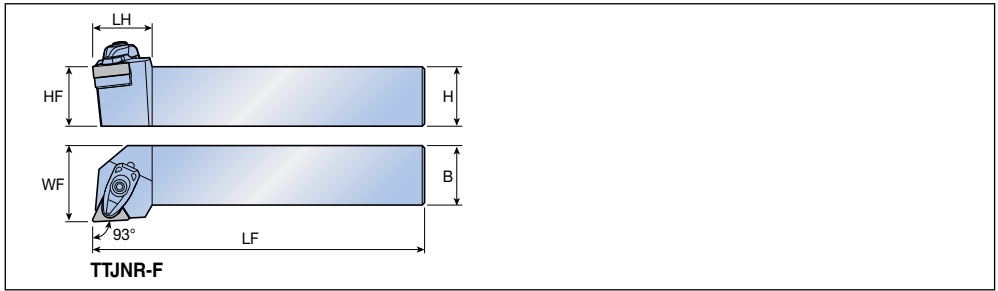

Approach angle	Designation	Dimension (mm)						Insert
		H	HF	B	LF	LH	WF	
93°	TTJNR/L 2020 K1604-F	20	20	20	125	25	25	TN...N 1604...
	2525 M1604-F	25	25	25	150	25	32	
	2020 K1607-F	20	20	20	125	25	25	TN...N 1607...
	2525 M1607-F	25	25	25	150	25	32	

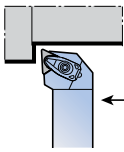

▶ TNGN 1604/1607 Inserts are not exchangeable on same holder

Spare parts

Designation	Clamp	Clamp screw	Spring	Shim	Shim screw	Wrench	
...16-F	DCL S-3F	DLS 3	DSP 3	TST 33	SO 40050I	L-W 3	T 15

2PLLNR/L 2PLBNR/L



Lever lock type holders with two pins

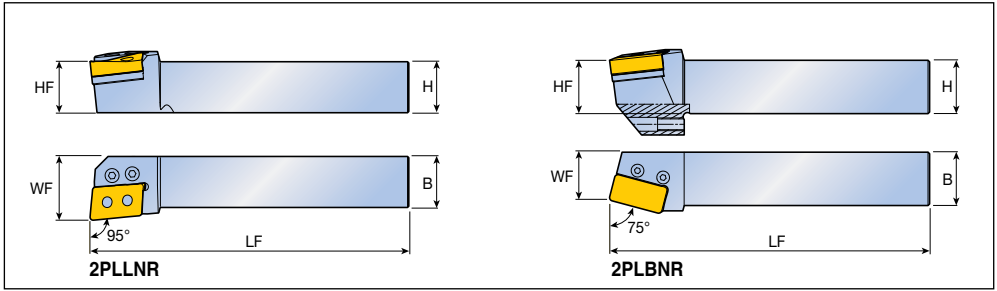

Approach angle	Designation	Dimension (mm)					Insert
		H	HF	B	LF	WF	
95°	2PLLNR/L 4040 S4012	40	40	40	250	50	LNMM 4012...HX A287
	5050 T4012	50	50	50	300	60	
75°	2PLBNR/L 5050 T5014	50	50	50	300	45	LNMX 5014...

Spare parts

Designation	Lever	Screw	Shim	Shim pin	Set screw	Wrench	
2PLLNR/L...	LCL 8	LCS 8-L39	LN 4025-T6.35-R/L	LSP 8	-	L-W 5	
2PLBNR/L...	LCL 8	LCS 8-L43	LN 5025-T6.35	LSP 8	SS M12x1.75x25	L-W 5	

TOP-RAIL holders

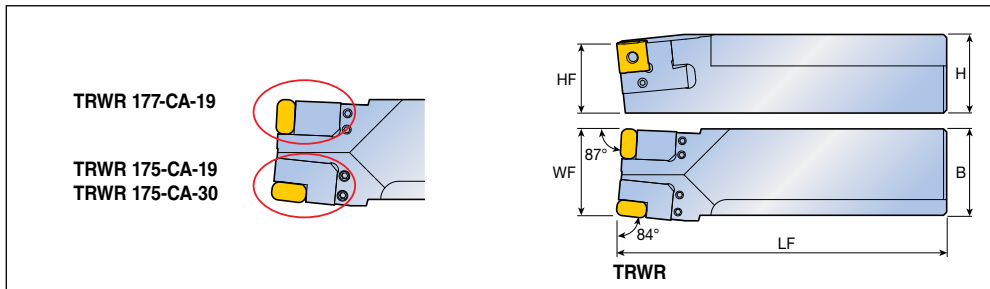

Approach angle	Designation	Dimension (mm)					Cartridge
		H	HF	B	LF	WF	
	* TRWR/L 50-55 TG	50	44	55	210	55	Left
							TRWR/L 175-CA-19
							TRWR/L 175-CA-30
							Right
							TRWR/L 177-CA-19

► *: Cartridges are not included in TOP-RAIL holder, please order separately.

TOP-RAIL cartridges

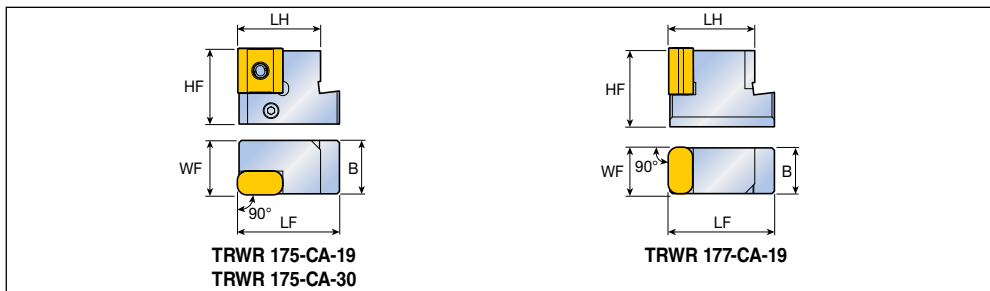

Designation	Dimension (mm)					Insert
	HF	B	LF	LH	WF	
TRWR/L 175-CA-19	32	22.6	43	35	23	LNMX 1919...
175-CA-30	32	22.6	43	35	23	LNMX 3019...
177-CA-19	32	18.6	43	35	19	LNMX 1919...



Spare parts

Designation	Screw	Pin	Lever	Screw	Wrench		
...50-55 TG	SS M6x1x16	PIN D5x13	-	-	L-W 3		
...CA...	-	-	LCL 5	LCS 5	L-W 3		

Hose

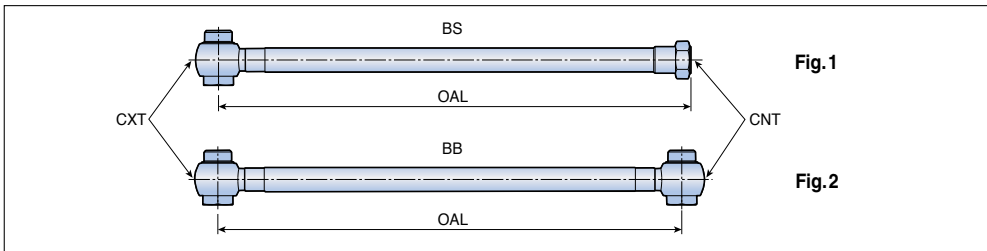

Designation	Dimension				Fig.
	OAL (mm)	CXT	CNT	Max.pressure (Bar)	
TB HOSE G1/8-7/16-200BS	200	G1/8-28 BSPP	7/16-20 UNF (Flare 37°)	260	1
G1/8-7/16-250BS	250	G1/8-28 BSPP	7/16-20 UNF (Flare 37°)	260	1
G1/8-G1/8-200BB	200	G1/8-28 BSPP	G1/8-28 BSPP	260	2
G1/8-G1/8-250BB	250	G1/8-28 BSPP	G1/8-28 BSPP	260	2
5/16-7/16-200BS	200	5/16-24 UNF	7/16-20 UNF (Flare 37°)	200	1
5/16-G1/8-200BS	200	5/16-24 UNF	G1/8-28 BSPP	200	1

► Hose is ordered separately

Spare parts

Designation	Bolt	Seal washer
TB HOSE 5/16-7/16-200BS	TB BANJO BOLT 5/16" UNF	TB COPPER SEAL 5/16"
TB HOSE G1/8-G1/8-200BB	TB BANJO BOLT G1/8"	TB COPPER SEAL 1/8"
TB HOSE G1/8-G1/8-250BB	TB BANJO BOLT G1/8"	TB COPPER SEAL 1/8"

► Bolt and Seal washer are ordered separately

Seal washer

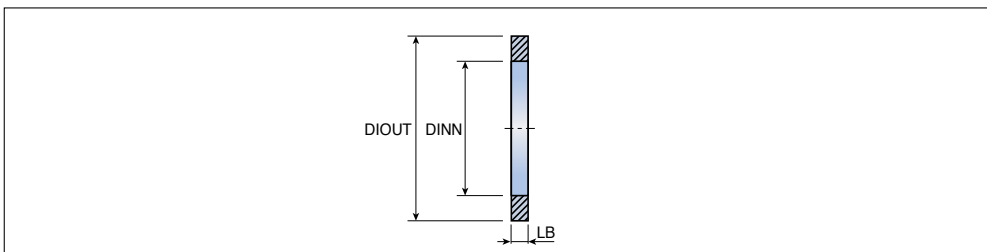

Designation	Dimension (mm)		
	DIOUT	DINN	LB
TB COPPER SEAL 1/8"	15	10	1
SEAL 5/16"	12	8	1

► Seal washer is ordered separately

Coupling system

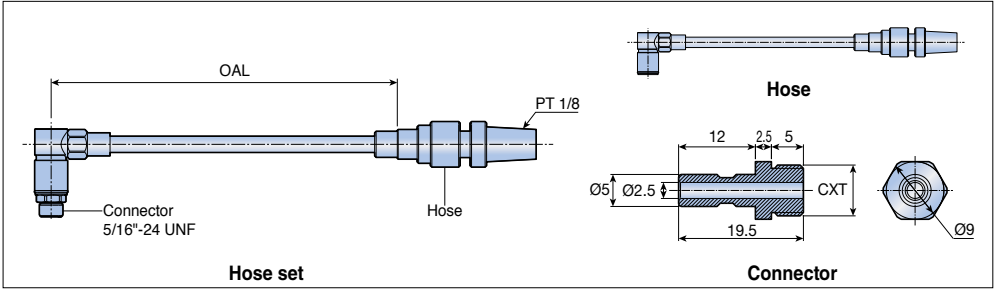

Components	Designation		Dimension		
			OAL (mm)	CXT	Maximum pressure (Bar)
Hose set	S-TB HOSE	R1/8-COUPLE-100	100	-	140
		R1/8-COUPLE-200	200	-	140
		R1/8-COUPLE-300	300	-	140
Hose	TB HOSE	R1/8-COUPLE-200	200	-	140
		R1/8-COUPLE-300	300	-	140
Connector	TB CONECTOR	5/16-COUPLE	-	5/16"-24 UNF	-
		G1/8-COUPLE	-	G1/8"-28 BSPP	-
		R1/8-COUPLE	-	PT 1/8"	-

► Hose set, hose and connector are ordered separately

Connector

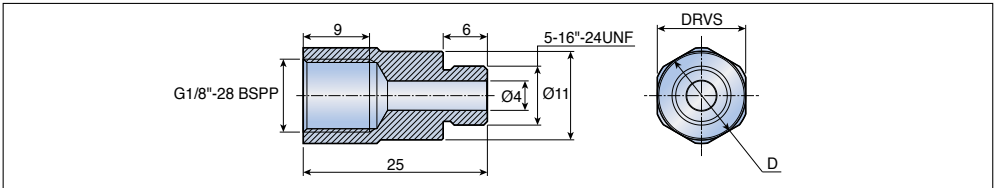

Designation	Dimension (mm)	
	D	DRVS
TB CONECTOR 5/16"-G1/8"	13	12
5/16"-G1/8"-12	12	11

► Connector is ordered separately

Adapter

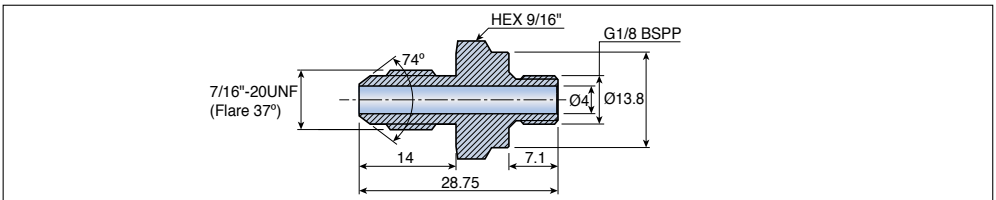

Designation
TB NIPPLE G1/8-7/16 UNF

► Adapter is ordered separately

QE1 SDJCR QE1 SDJCR-TB

Screw type modular heads for external turning

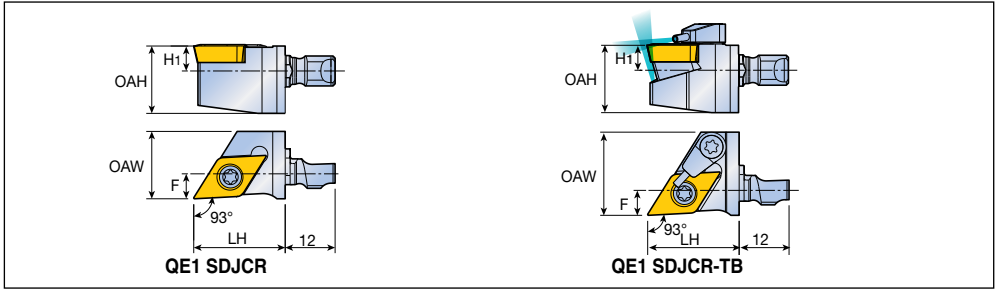

Approach angle	Designation	Dimension (mm)					Shank	Insert
		OAH	LH	OAW	H1	F		
93°	QE1 SDJCR 11	16.2	22.0	16.2	6.0	7.0	QE1 S12N-TB QE1 S16R-TB	DC... 11T3... A265-A268, A311
93°	QE1 SDJCR 11-TB	16.2	22.0	20.0	6.0	7.0		

Spare parts

Designation	Screw	Cooling unit	Wrench			
...11	SO 35080I	-	T 15			
...11-TB	SO 35080I	S-CU-TB	T 15			

QE1 SVJBR QE1 SVJBR-TB

Screw type modular heads for external turning

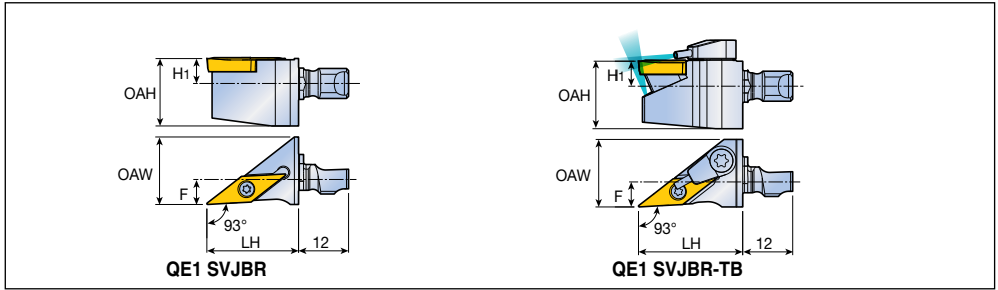

Approach angle	Designation	Dimension (mm)					Shank	Insert
		OAH	LH	OAW	H1	F		
93°	QE1 SVJBR 11	16.2	22.0	16.2	6.0	7.0	QE1 S12N-TB QE1 S16R-TB	VB.. 1103.. A281, A282, A315
93°	QE1 SVJBR 11-TB	16.2	25.0	16.2	6.0	7.0		

Spare parts

Designation	Screw	Cooling unit	Wrench			
...11	SO 25065I	-	T 7			
...11-TB	SO 25065I	S-CU-TB	T 7			

QE1 SVJCR QE1 SVJCR-TB

Screw type modular heads for external turning

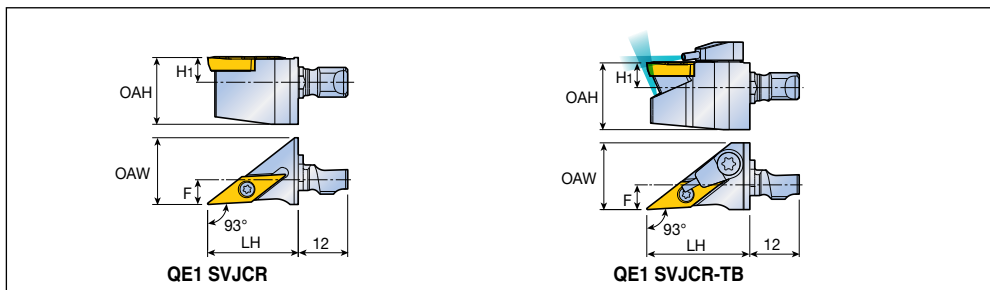

Approach angle	Designation	Dimension (mm)					Shank	Insert
		OAH	LH	OAW	H1	F		
93°	QE1 SVJCR 11	16.2	22.0	16.2	6.0	7.0	QE1 S12N-TB QE1 S16R-TB	VC... 1103... A283, A284, A315
93°	QE1 SVJCR 11-TB	16.2	25.0	16.2	6.0	7.0		





Spare parts

Designation	Screw	Cooling unit	Wrench			
...11	SO 25065I	-	T 7			
...11-TB	SO 25065I	S-CU-TB	T 7			

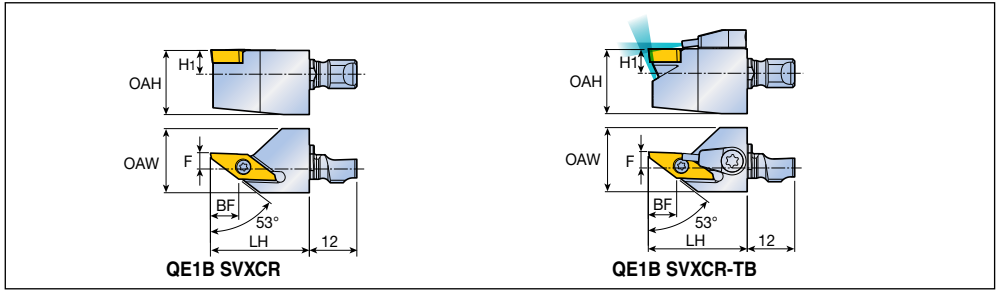

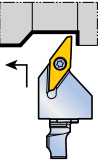
QE1B SVXCR QE1B SVXCR-TB

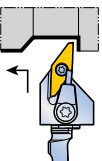
Screw type modular heads for back turning



Approach angle	Designation	Dimension (mm)						Shank	Insert
		OAH	LH	OAW	BF	H1	F		
53° 	QE1B SVXCR 11	16.2	25.0	16.2	7.2	6.0	3.0	QE1 S12N-TB QE1 S16R-TB BTVC 1103..  A259	
53°  COOLMIST	QE1B SVXCR 11-TB	16.2	25.0	16.2	7.2	6.0	3.0	BTVC 1103..  A259	

Spare parts

Designation	Screw	Cooling unit	Wrench			
...11	SO 25065I 	- 	T 7 			
...11-TB	SO 25065I	S-CU-TB	T 7			

QE1Y SDJCR QE1Y SDJCR-TB



Screw type Y-axis modular heads

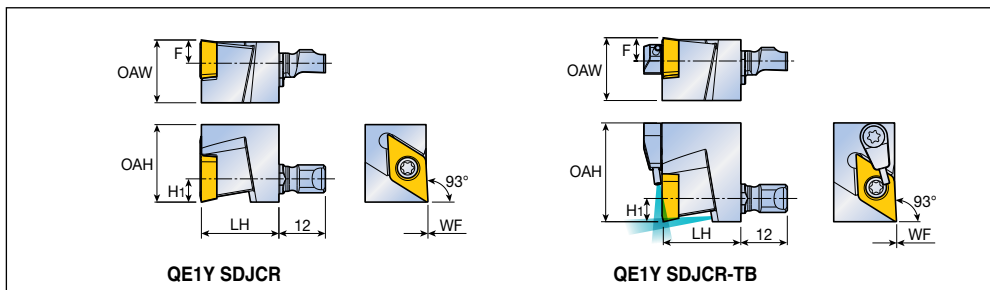

Approach angle	Designation	Dimension (mm)						Shank	Insert
		OAW	OAH	LH	WF	H1	F		
93°	QE1Y SDJCR 11	16.2	20.0	20.0	0.0	6.0	7.0	QE1 S12N-TB QE1 S16L-TB	DC.. 11T3.. A265-A268, A311
93°									
93°	QE1Y SDJCR 11-TB	16.2	25.5	20.0	0.0	6.0	7.0		
93°									

Spare parts

Designation	Screw	Cooling unit	Wrench			
...11	SO 35080I	-	T 15			
...11-TB	SO 35080I	S-CU-TB	T 15			

QE1 S12N-TB QE1 S16R/L-TB



High pressure coolant shanks for WIN-SWISS modular head

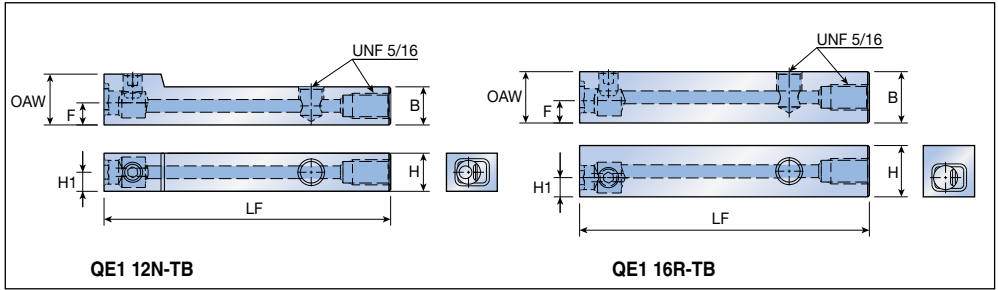

Designation	Dimension (mm)						Modular head
	H	H1	B	LF	OAW	F	
QE1 S12N-TB	12	6	12	107	16	7	QE1...R(-TB) QE1B...R(-TB) A137-A141 QE1Y...R(-TB)
QE1 S16R-TB	16	6	16	107	16	7	QE1...R(-TB) QE1B...R(-TB)
QE1 S16L-TB	16	6	16	107	16	7	QE1Y...R(-TB)

Head designation	70 bar flow rate (ℓ/min)	100 bar flow rate (ℓ/min)	140 bar flow rate (ℓ/min)
QE1 SDJCR-TB *	9-11	11-13	14-16
QE1B SVXCR-TB	8-10	9-11	11-13
QE1Y SDJCR-TB	13-15	15-17	18-20

► * QE1 SVJBR, SVJCR, SDJNR same flow rate

Spare parts

Designation	Screw	Plug	Wrench	
	QE1...-TB	SS M6F-7	PLG 5/16 UNF	L-W 3

► Please refer to A135 page for COOL-BURST accessories

QE1 FIX-20100

Insert replacement fixture

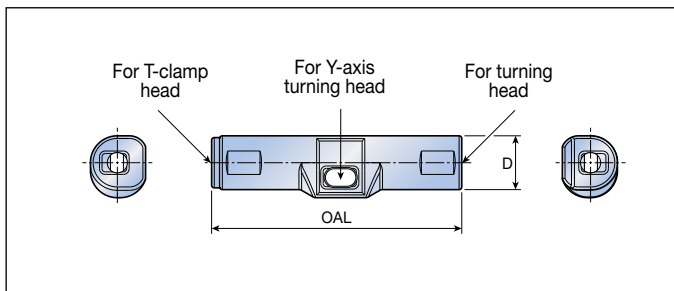

Designation	Dimensions (mm)	
	OAL	D
QE1 FIX-20100	93.0	20.0

► Fixture ordered separately

Insert replacement

► Due to the WIN-SWISS' small head sizes, replacing the inserts could be difficult.
Please use the fixture to facilitate insert replacement.

► Y-axis turning head

► T-clamp head

► Turning head



C4 - T C L N R

1
2
3
4
5
6

1 Coupling size

	Symbol	DCONMS(mm)
	C4	40
	C5	50
	C6	63

2 Clamping system

P	C	S	M	T	W	H
Lever lock	Top clamp	Screw clamp	Multi lock	T-holder	Wedge clamp	Hook lever

3 Insert shape

C	D	E	H	K	R	S	T	V	W

4 Approach angle

Symbol	Shape	Offset	Symbol	Shape	Offset	Symbol	Shape	Offset
A		x	J		o	V		x
			K		o	W		o
B		x	L		o	X	Special angle	
			M		x	C*		x
D		x	N		x	H*		o
E		x	R		o	Q*		o
F		o	S		o			
G		o	T		o			
			U		o			

* TaeguTec standard

27 055 - 09

7

8

9

10

5 Insert clearance angle

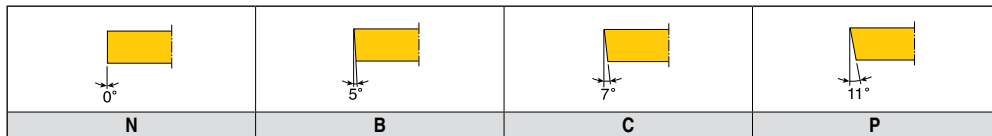

6 Hand of tool

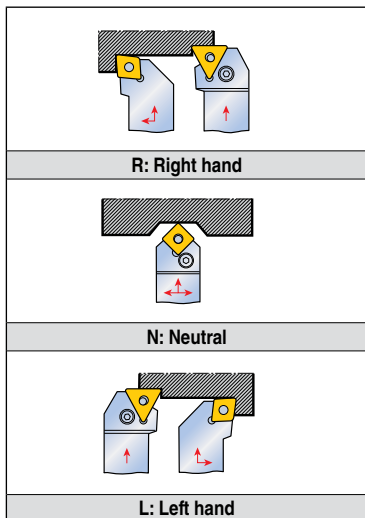

7 WF dimension (mm)

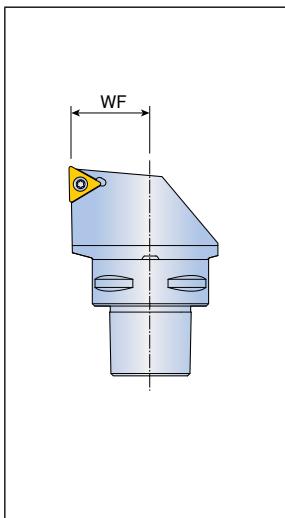

8 Tool length (mm)

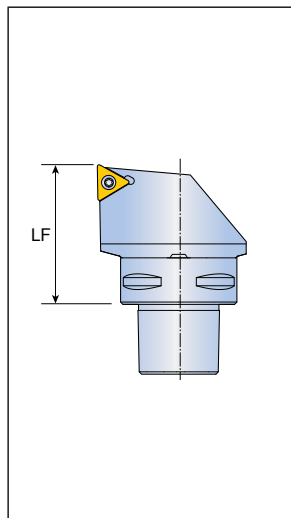

9 Cutting edge length

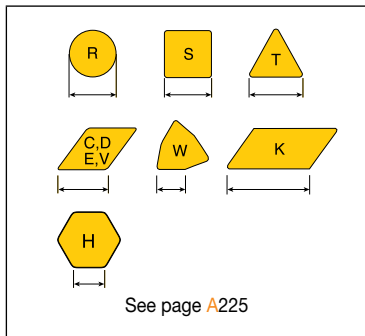

10 Manufacturer's type designation

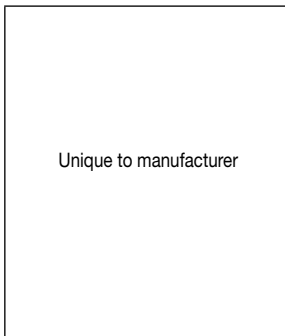





C...TCLNR/L C...TDJNR/L

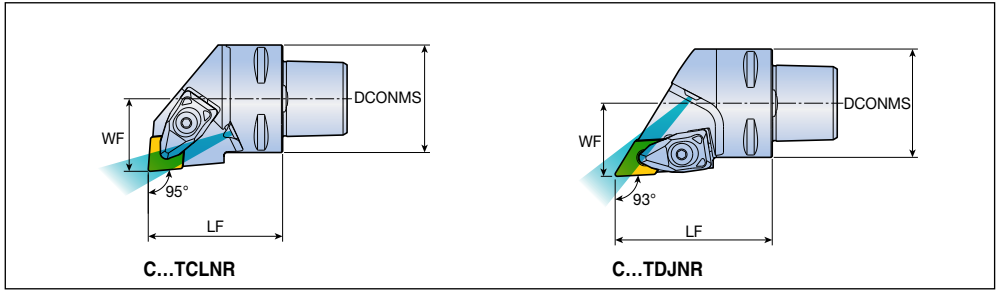

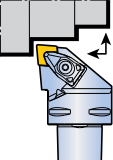

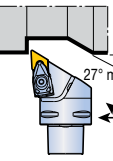





T-holders with C-ADAPTER



Approach angle	Designation	Dimension (mm)			Insert
		DCONMS	WF	LF	
95° 	C4-TCLNR/L 27050-12	40	27	50	CN...1204...  A226, A228-A232, CN...1606... A291, A292, CN...1906... A303
	C5-TCLNR/L 35060-12	50	35	60	
	C6-TCLNR/L 45065-12	63	45	65	
	C4-TCLNR/L 27055-16	40	27	55	
	C5-TCLNR/L 35060-19	50	35	60	
	C6-TCLNR/L 45065-19	63	45	65	
93° 	C4-TDJNR/L 27058-1504	40	27	58	DN...1504...  DN...1506... A234-A238, DN...1504... A293, A304 DN...1506... DN...1504... DN...1506...
	C4-TDJNR/L 27058-1506	40	27	58	
	C5-TDJNR/L 35060-1504	50	35	60	
	C5-TDJNR/L 35060-1506	50	35	60	
	C6-TDJNR/L 45065-1504	63	45	65	
	C6-TDJNR/L 45065-1506	63	45	65	

Spare parts

Designation	Clamp	Clamp screw	Spring	Shim		Shim screw	Nozzle	Wrench	
									
C4...12	DLM 4	DLS 4	DSP 4	TSC 44	-	SO 40050I	NZ 83	L-W 3	T 15
...12	DLM 4	DLS 4	DSP 4	TSC 44	-	SO 40050I	NZ 104	L-W 3	T 15
...16	DLM 5	DLS 5	DSP 5	TSC 54	-	SO 50090I	NZ 83	L-W 4	T 20
...19	DLM 6	DLS 5	DSP 5	LSC 63	-	SO 80180I	NZ 104	L-W 4	T 20
...1504	DLM 4	DLS 4	DSP 4	-	TSD 44	SO 40050I	NZ 83	L-W 3	T 15
C4...1506	DLM 4	DLS 4	DSP 4	-	TSD 43	SO 40050I	NZ 83	L-W 3	T 15
...1506	DLM 4	DLS 4	DSP 4	-	TSD 43	SO 40050I	NZ 104	L-W 3	T 15

C...TSDNN C...TSSNR/L



T-holders with C-ADAPTER

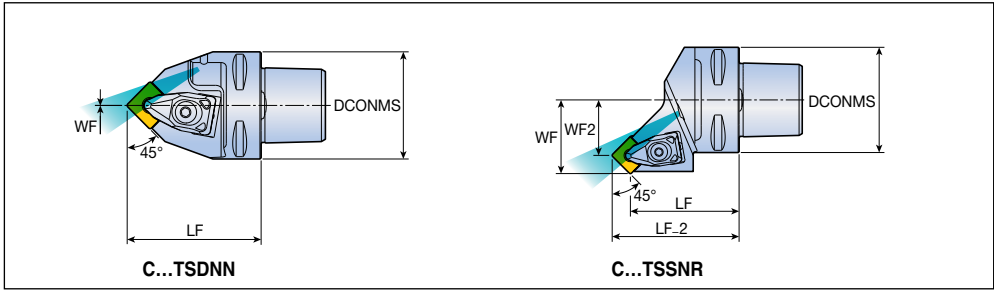

Approach angle	Designation	Dimension (mm)					Insert
		DCONMS	WF	WF2	LF	LF_2	
45°	C4-TSDNN 00050-12	40	-	-	50	-	SN...1204... A241, A243-A246
	C5-TSDNN 00060-12	50	-	-	60	-	
	C6-TSDNN 00065-12	63	-	-	65	-	
45°	C4-TSSNR/L 27042-12	40	27	18.7	42	50.3	
	C5-TSSNR/L 35052-12	50	35	26.7	52	60.3	
	C6-TSSNR/L 45056-12	63	45	36.7	56	64.3	

Spare parts





Designation	Clamp	Clamp screw	Spring	Shim	Shim screw	Nozzle	Wrench	
C4...12	DLM 4	DLS 4	DSP 4	TSS 44	SO 40050I	NZ 83	L-W 3	T 15
...12	DLM 4	DLS 4	DSP 4	TSS 44	SO 40050I	NZ 104	L-W 3	T 15

C...TTGNR/L C...TTJNR/L C...TVJNR/L

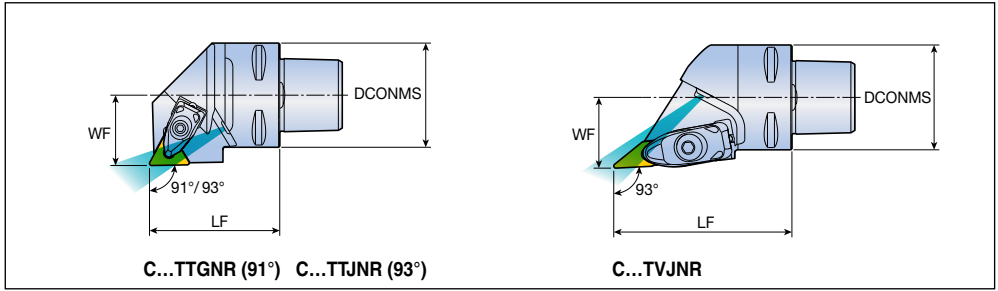

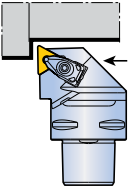

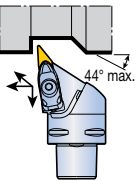





T-holders with C-ADAPTER



Approach angle	Designation	Dimension (mm)			Insert	
		DCONMS	WF	LF		
91°/93° 	C4-TTGNR/L 27050-16	40	27	50	TN...1604...  A247-A250, A299, A307	
	C5-TTGNR/L 35060-16	50	35	60		
	C6-TTGNR/L 45065-16	63	45	65		
	C4-TTJNR/L 27050-16	40	27	50		
	C5-TTJNR/L 35060-16	50	35	60		
	C6-TTJNR/L 45065-16	63	45	65		
93° 	C4-TVJNR/L 27068-16	40	27	68	VN...1604...  A251-A252, A300, A308	
	C5-TVJNR/L 35065-16	50	35	65		
	C6-TVJNR/L 45068-16	63	45	68		

Spare parts

Designation	Clamp	Clamp screw	Spring	Shim		Shim screw	Nozzle	Wrench	
C4...TT...16									
...TT...16	DLM 3	DLS 3	DSP 3	TST 33	-	SO 35080I	NZ 83	L-W 2.5	T 15
C4...TV...16	DLM 3V	DLS 5	DSP 5	-	TSV 33	SO 35080I	NZ 83	L-W 4	T 15
...TV...16	DLM 3V	DLS 5	DSP 5	-	TSV 33	SO 35080I	NZ 104	L-W 4	T 15

High pressure T-holders with C-ADAPTER

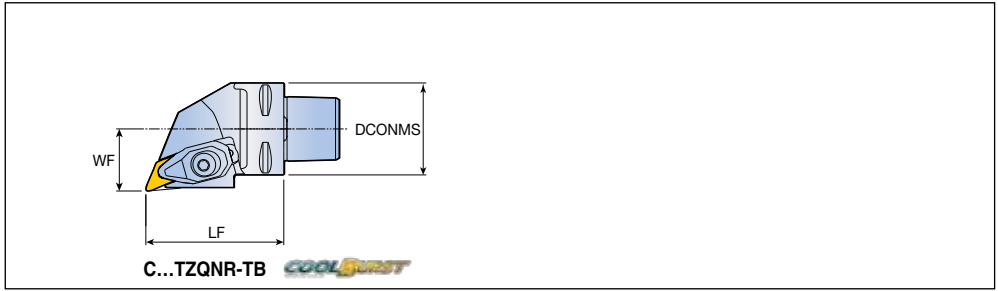

Approach angle	Designation	Dimension (mm)			Insert
		DCONMS	WF	LF	
ZNMV 23°(BWT) 95°(FWT)	C4-TZQNR/L 27060-1410-TB	40	27	60	ZNMV 1410... A258
	C5-TZQNR/L 35060-1410-TB	50	35	60	
	C6-TZQNR/L 45065-1410-TB	63	45	65	

ZNMV Y-BF 28°(BWT) 118°(FWT)			
	ZNMV	ZNMV Y-BF	

- ▶ BWT: Backward turning
- ▶ FWT: Forward turning

Spare parts





Designation	Clamp	Clamp screw	Spring	Shim	Shim screw	Wrench	
C...1410-TB	DLM 3.3Z-NV	DLS 5	DSP 5	TSZ 140310	TS 350831/HG	L-W 4	T 10

C...SCLCR/L C...SDJCR/L

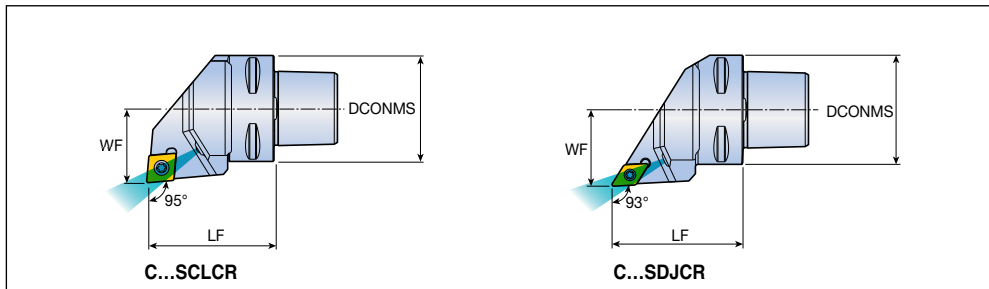

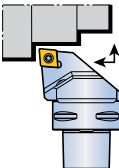

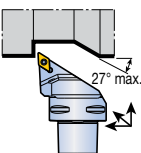



Screw type holders with C-ADAPTER



Approach angle	Designation	Dimension (mm)			Insert	
		DCONMS	WF	LF		
95° 	C4-SCLCR/L 27050-09	40	27	50	CC... 09T3...  A260-A263, A310	
	C5-SCLCR/L 35060-09	50	35	60		
	C6-SCLCR/L 45065-09	63	45	65		
	C4-SCLCR/L 27050-12	40	27	50		CC... 1204...
	C5-SCLCR/L 35060-12	50	35	60		
	C6-SCLCR/L 45065-12	63	45	65		
93° 	C4-SDJCR/L 27050-11	40	27	50	DC... 11T3...  A265-A268, A311	
	C5-SDJCR/L 35060-11	50	35	60		
	C6-SDJCR/L 45065-11	63	45	65		

Spare parts





Designation	Screw	Shim		Shim screw	Nozzle	Wrench	
							
C4...09	SO 35124I	SSC 32	-	SO 50090S	NZ 83	T 15	L-W 3.5
...09	SO 35124I	SSC 32	-	SO 50090S	NZ 104	T 15	L-W 3.5
C4...11	SO 35124I	-	SSD 32	SO 50090S	NZ 83	T 15	L-W 3.5
...11	SO 35124I	-	SSD 32	SO 50090S	NZ 104	T 15	L-W 3.5
C4...12	SO 45130I	SSC 43N	-	SO 60105S	NZ 83	T 20	L-W 5
...12	SO 45130I	SSC 43N	-	SO 60105S	NZ 104	T 20	L-W 5

C...SRDCN C...STGCR/L C...STJCR/L

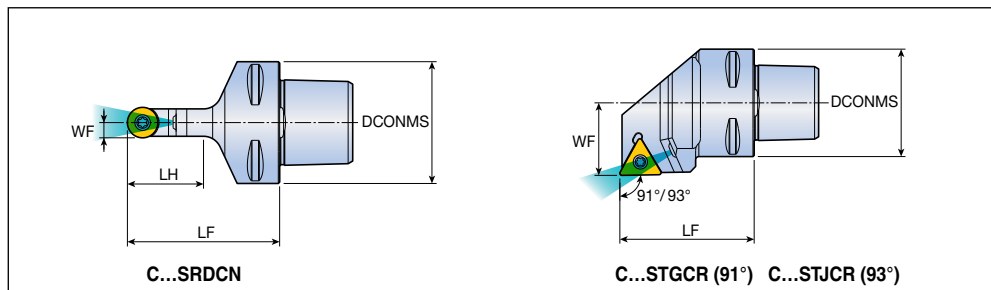

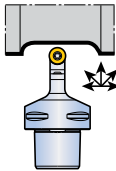

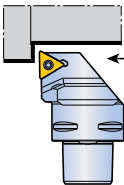



Screw type holders with C-ADAPTER



Approach angle	Designation	Dimension (mm)				Insert
		DCONMS	WF	LF	LH	
45° 	C4-SRDCN 00050-10A	40	5	50	25	RC...T 10T3...  A271
	C5-SRDCN 00060-10A	50	5	60	25	
	C6-SRDCN 00065-10A	63	5	65	25	
	C4-SRDCN 00050-12A	40	6	50	28	RC...T 1204...
	C5-SRDCN 00060-12A	50	6	60	28	
	C6-SRDCN 00065-12A	63	6	65	28	
91°/93° 	C4-STGCR/L 27050-16	40	27	50	-	TC... 16T3...  A275, A313, A314
	C5-STGCR/L 35060-16	50	35	60	-	
	C4-STJCR/L 27050-16	40	27	50	-	
	C5-STJCR/L 35060-16	50	35	60	-	

Spare parts

Designation	Screw	Shim	Shim screw	Nozzle	Wrench		
							
C4...10A	TS 40097I	TRC 3-0	-	SR TC-3	NZ 62	T 15	-
...10A	TS 40097I	TRC 3-0	-	SR TC-3	NZ 62	T 15	-
C4...12A	SO 40050I	TRC 4-0	-	SR TC-4S	NZ 62	T 15	-
...12A	SO 40050I	TRC 4-0	-	SR TC-4S	NZ 62	T 15	-
C4...16	SO 35124I	-	SST 32	SO 50090S	NZ 83	T 15	L-W 3.5
...16	SO 35124I	-	SST 32	SO 50090S	NZ 104	T 15	L-W 3.5

C...SVJBR/L C...SVBVB



Screw type holders with C-ADAPTER

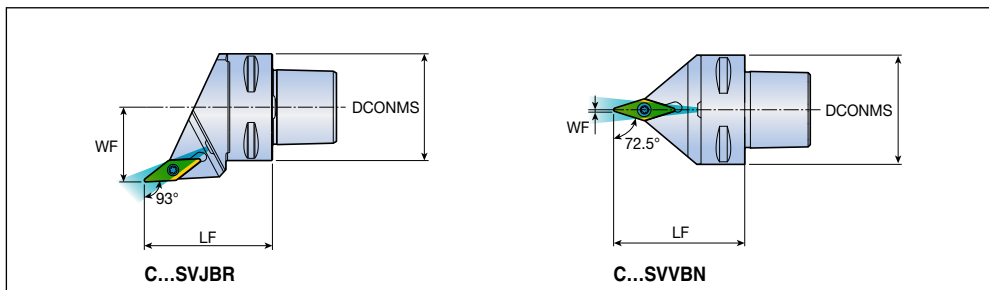

Approach angle	Designation	Dimension (mm)			Insert
		DCONMS	WF	LF	
93°	C4-SVJBR/L 27050-16	40	27	50	VB...T 1604... A281, A282, A315
	C5-SVJBR/L 35060-16	50	35	60	
	C6-SVJBR/L 45065-16	63	45	65	
72.5°	C4-SVBVB 00050-16	40	0.6	50	
	C5-SVBVB 00060-16	50	0.6	60	
	C6-SVBVB 00065-16	63	0.6	65	

Spare parts

Designation	Screw	Shim	Shim screw	Nozzle	Wrench			
C4...16	SO 35124I	SSV 32	SO 50090S	NZ 83	T 15	L-W 3.5		
...16	SO 35124I	SSV 32	SO 50090S	NZ 104	T 15	L-W 3.5		

C...SCLCR/L C...SDUCR/L



Screw type boring bar with C-ADAPTER

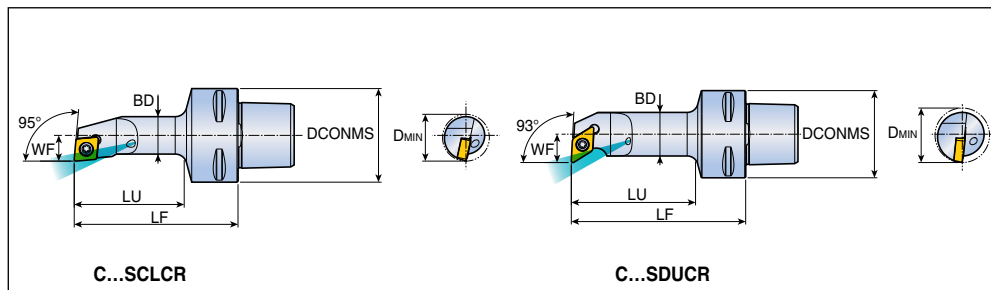

Approach angle	Designation	Dimension (mm)						Insert
		DCONMS	LF	LU	WF	BD	DMIN	
95°	C4-SCLCR/L-11070-09	40	70	47	11	16	20	CCMT 09T3... A263
	C5-SCLCR/L-11070-09	50	70	46	11	16	20	
93°	C4-SDUCR/L-13080-11	40	80	57	13	20	25	DCMT 11T3... A268
	C5-SDUCR/L-13080-11	50	80	56	13	20	25	

Spare parts

Designation	Screw	Wrench				
C...SCLCR/L	SO 35080I	T 15				
C...SDUCR/L	SO 35080I	T 15				

C...STFCR/L C...SVQBR/L



Screw type boring bar with C-ADAPTER

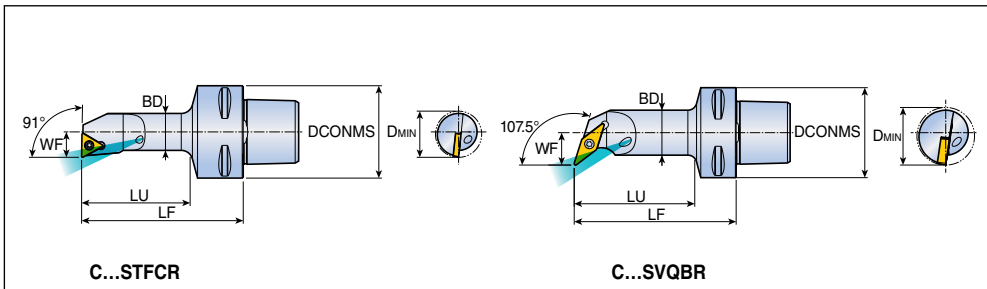

Approach angle	Designation	Dimension (mm)						Insert		
		DCONMS	LF	LU	WF	BD	DMIN			
91°	C4-STFCR/L-11070-1102	40	70	47	11	16	20	TC...T 1102... A275, A276, A313-A314		
	C5-STFCR/L-11070-1102	50	70	46	11	16	20			
107.5°	C4-SVQBR/L-18090-16	40	90	68	18	25	32		VBMT 1604... A282	
	C5-SVQBR/L-18090-16	50	90	67	18	25	32			

Spare parts

Designation	Screw	Wrench				
C...STFCR/L	SO 25065I	T 7				
C...SVQBR/L	SO 35080I	T 15				

Reduction sleeves for bars, used in holders with exchangeable adaptation

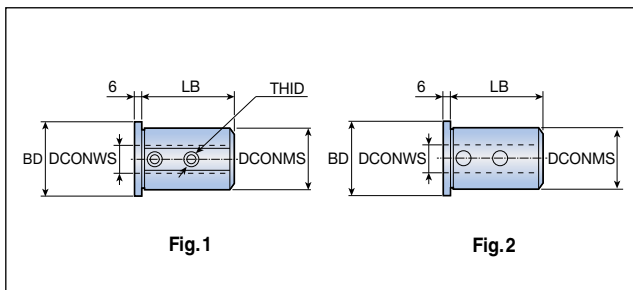

Designation	Dimension (mm)					Fig.
	DCONMS	DCONWS	BD	LB	THID	
SC 25T6A	25	6	31	56	M6	1
25T8A	25	8	31	56	M8	1
25T10A	25	10	31	56	M8	1
25T12A	25	12	31	56	M8	1
25T16B	25	16	31	56	-	2
25T20B	25	20	31	56	-	2
SC 40T6A	40	6	46	60	M6	1
40T8A	40	8	46	60	M8	1
40T10A	40	10	46	60	M8	1
40T12A	40	12	46	60	M8	1
40T16B	40	16	46	60	-	2
40T20B	40	20	46	60	-	2
40T25B	40	25	46	60	-	2
40T32B	40	32	46	60	-	2
SC 50T6A	50	6	56	70	M6	1
50T8A	50	8	56	70	M8	1
50T10A	50	10	56	70	M8	1
50T12A	50	12	56	70	M8	1
50T16B	50	16	56	80	-	2
50T20B	50	20	56	80	-	2
50T25B	50	25	56	80	-	2
50T32B	50	32	56	80	-	2

Spare parts

Designation	Screw		Wrench		
...25T/50T 6A	SR M6x6 DIN916	-	L-W 3*		
...25T 8A/10A/12A	SR M8x6 DIN916	-	L-W 4*		
...50T 8A/10A/12A	SR M8x6 DIN916	-	L-W 4*		
...40T 6A	-	SR M6x10 DIN1835-B	L-W 3*		
...40T 8A/10A/12A	-	SR M8x10 DIN1835-B	L-W 4*		

► *: Optional, should be ordered separately

Holders for boring bars with C-ADAPTER exchangeable shanks

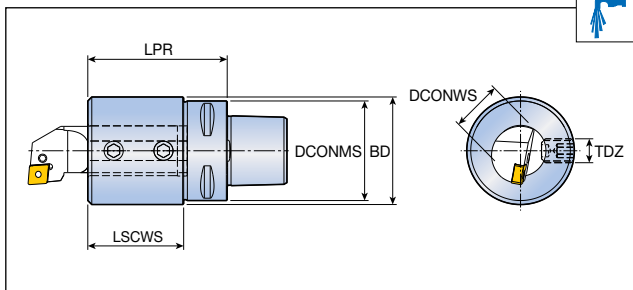

Designation	Dimension (mm)					
	DCONMS	LPR	LSCWS	DCONWS	BD	TDZ
C8 ADI 12	80	70	36	12	36	M8
ADI 16	80	70	36	16	36	M8
ADI 20	80	70	40	20	36	M10
ADI 25	80	80	51	25	54	M12
ADI 32	80	110	86	32	68	M12
ADI 40	80	115	86	40	98	M12
ADI 50	80	115	86	50	98	M12

Spare parts

Designation	Screw	Wrench				
...10	SR M6x10 DIN1835-B	L-W 3*				
...12/16	SR M8x10 DIN1835-B	L-W 4*				
...20	SR M10x12 DIN1835-B	L-W 5*				
...25/32/40/50	SR M12x16 DIN1835-B	L-W 6*				

► *: Optional, should be ordered separately

S 32 S - C T F P R - 16 -

1 2 3 4 5 6 7 8 9 10

1 Boring bar

S	Steel shank
A	Coolant through steel shank
C	Carbide shank
E	Coolant through carbide shank
X	Special

2 Bar diameter

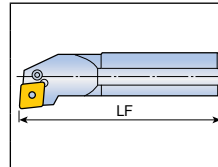
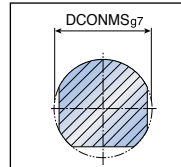

K	125	U	350
M	150	V	400
Q	180	W	450
R	200	Y	500
S	250	X	Special
T	300		

4 Clamping system

Lever lock	Top clamp	Screw clamp	Multi lock	T-holder	Wedge clamp	Hook lever

5 Insert shape

C	D	E	H	K	R	S	T	V	W

6 Approach angle

L	K	U	Z	F	Q	P

7 Insert clearance angle

N	B
C	P

8 Hand of tool

R	
	Right hand Left handed insert used
L	
	Left hand Right handed insert used

9 Cutting edge length

See page A225		

10 Manufacturer's type designation

Unique to manufacturer

Top clamp type boring bars

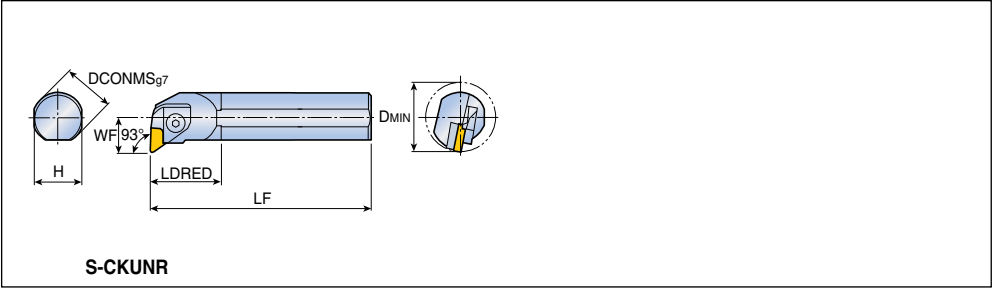

Approach angle	Designation	Dimension (mm)						Insert
		DCONMS	H	LF	LDRED	WF	DMIN	
93°	S32T CKUNR/L 16	32	30	300	45	22	44	KNUX 1604...R/L A239
	S40T CKUNR/L 16	40	37	300	55	27	54	
	S40V CKUNR/L 16	40	37	400	55	27	54	
	S50U CKUNR/L 16	50	47	350	60	35	67.2	

Spare parts

Designation	Clamp	Screw	Clamp spring	Shim	Shim screw	Pin & spring	Wrench	
...16	CL 16KR/L	CLS 16K	KSP 90	CSK 1604R/L	FH M3x0.5 x10	KSP 48 KP 48S	L-W 4	

S-CTFCR/L S-CTFPR/L



Top clamp type boring bars

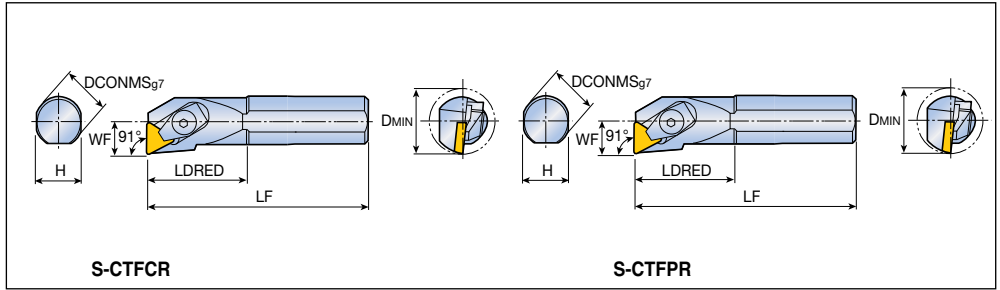

Approach angle	Designation	Dimension (mm)						Insert
		DCONMS	H	LF	LDRED	WF	DMIN	
91°	S10K CTFCR/L 06	10	9	125	25	6.5	12	TCGR 0601...
91°	S10K CTFPR/L 06	10	9	125	25	6.5	12	TP...R 0601...
	S12M CTFPR/L 06	12	11	150	30	9	16	
	S12M CTFPR/L 09	12	11	150	25	9	16	TP...R, TP...N 0902...
	S12M CTFPR/L 11	12	11	150	30	9	16	TP...R, TP...N 1103...
	S16R CTFPR/L 11	16	15	200	30	11	20	TP...R, TP...N 1603...
	S20S CTFPR/L 11	20	18	250	35	13	25	
	S16R CTFPR/L 16	16	15	200	40	11	20	
	S20S CTFPR/L 16	20	18	250	50	13	25	
	S25T CTFPR/L 16	25	23	300	40	17	32	
	S32T CTFPR/L 16	32	30	300	45	22	40	
	S40T CTFPR/L 16	40	37	300	41.5	27	50	TPMR, TP...N 2204...
	S50U CTFPR/L 16	50	47	350	56	35	63	
	S40T CTFPR/L 22	40	37	300	41.5	27	50	
	S50U CTFPR/L 22	50	47	350	56	35	63	

A278-A280,

 A302,

 A313-A314

Spare parts

Designation	Clamp			Screw	Snap ring	Shim	Shim pin	Wrench
...06	CL 1.25	-	-	CLS 1.25	CSR 1.25	-	-	L-W 1.5
...09	CL 1.25	-	-	CLS 1.25	CSR 1.25	-	-	L-W 1.5
...11	-	CL 2C	-	CLS 2C	CSR 2C	-	-	L-W 2.5
S16R...16	-	CL 3C	-	CLS 3C	CSR 2	-	-	L-W 3
S20S...16	-	CL 3C	-	CLS 3C	CSR 2	-	-	L-W 3
S25T...16	-	-	CL 3	CLS 3S	WSR 4	-	-	L-W 3
...16	-	-	CL 3	CLS 3	WSR 4	CST 32	CSP 3	L-W 3
...22	-	-	CL 4	CLS 4	CSR 4	CST 43	CSP 16K	L-W 4

Hook lever type boring bars

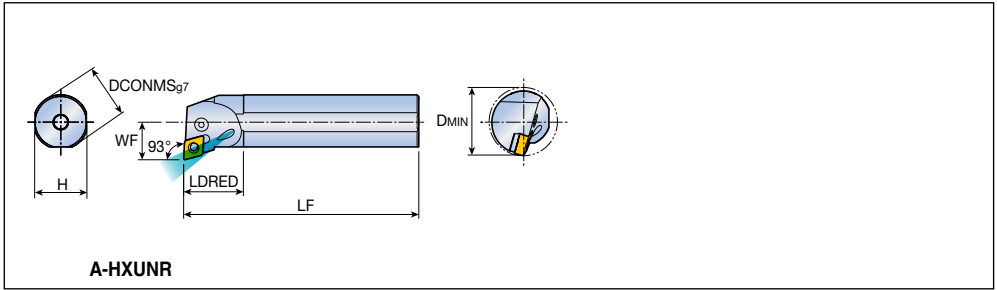

Approach angle	Designation	Dimension (mm)						Insert
		DCONMS	H	LF	LDRED	WF	DMIN	
93°	A32S HXUNR/L 1105	32	30	250	35	22	40	XN... 1105...
								 A257

Spare parts

Designation	Lever	Lever screw	Shim	Shim pin	Wrench			
...1105	LCL 11-NX	LCS 4S	LSX 3.52B	LSP 4	L-W 3			

Lever lock type boring bars

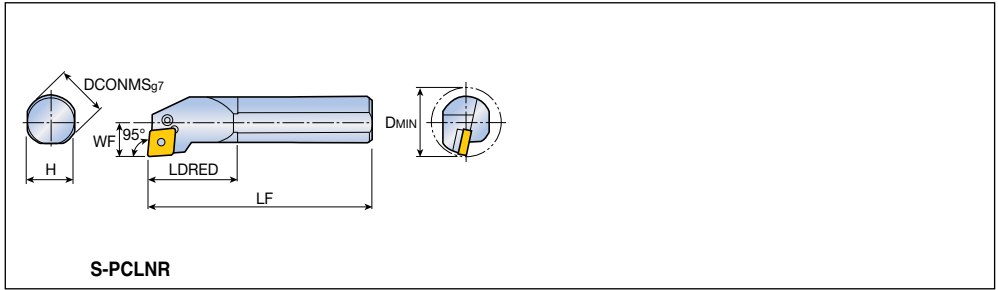

Approach angle	Designation	Dimension (mm)						Insert
		DCONMS	H	LF	LDRED	WF	DMIN	
95°	S25T PCLNR/L12	25	23	300	40	17	32	CN...1204... A226, A228-A232, A233, A291, A292, A303
	S32T PCLNR/L12	32	30	300	45	22	40	
	S40T PCLNR/L12	40	37	300	55	27	50	
	S50U PCLNR/L12	50	47	350	70	35	63	
	S50U PCLNR/L16	50	47	350	70	35	63	
	S50U PCLNR/L19	50	47	350	70	35	63	
								CN...1606...
								CN...1906...

Spare parts

Designation	Lever	Screw	Shim	Shim pin	Snap ring	Wrench		
S25T...12	LCL 4B	LCS 4B	-	-	LSR 4B	L-W 2.5		
S32 ...12	LCL 4	LCS 4S	LSC 42	LSP 4	-	L-W 3		
...12	LCL 4	LCS 4	LSC 42	LSP 4	-	L-W 3		
...16	LCL 5	LCS 5	LSC 53	LSP 5	-	L-W 3		
...19	LCL 6D	LCS 6	LSC 63	LSP 6	-	L-W 4		

S-PDUNR/L S-PDZNR/L



Lever lock type boring bars

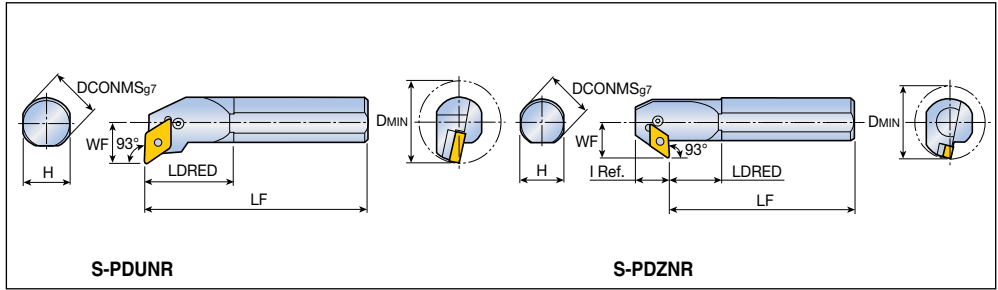

Approach angle	Designation	Dimension (mm)							Insert
		DCONMS	H	LF	LDRED	WF	I	DMIN	
 93°	S32T PDUNR/L 15	32	30	300	45	22	-	40	DN...1506... A234-A238, A293, A304
	S40T PDUNR/L 15	40	37	300	55	27	-	50	
	S50U PDUNR/L 15	50	47	350	70	35	-	63	
	S32T PDUNR/L 15-A	32	30	300	35	22	-	40	
 93° For back boring	S32T PDZNR/L 15	32	30	300	30	25	26	45	DN...1506...
	S40T PDZNR/L 15	40	37	300	35	29	26	50	
	S50U PDZNR/L 15	50	47	350	45	35	27	63	

Spare parts

Designation	Lever	Screw	Shim	Shim pin	Wrench			
	S32T ...15	LCL 4A	LCS 4S	LSD 42	LSP 4	L-W 3		
S40T PDZ ...15	LCL 4A	LCS 4S	LSD 42	LSP 4	L-W 3			
...15	LCL 4A	LCS 4	LSD 42	LSP 4	L-W 3			
...15-A	LCL 4A	LCS 4S	LSD 42	LSP 4	L-W 3			

Lever lock type boring bars

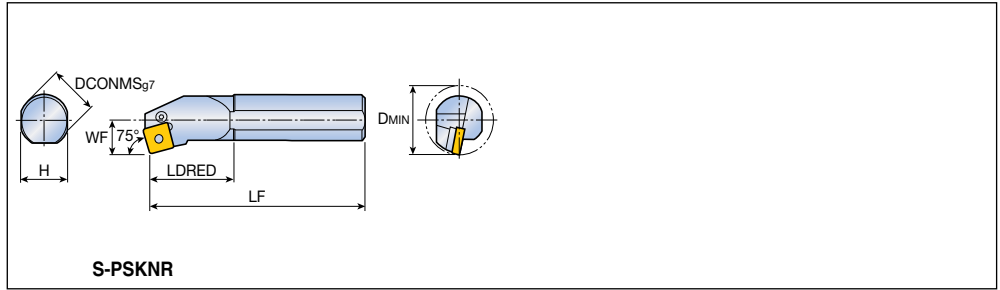

Approach angle	Designation	Dimension (mm)						Insert
		DCONMS	H	LF	LDRED	WF	DMIN	
75°	S25T PSKNR/L12	25	23	300	33	17	32	SN...1204... A241-A246, A296, A297, A306
	S32T PSKNR/L12	32	30	300	45	22	40	
	S40T PSKNR/L12	40	37	300	41.5	27	50	
	S50U PSKNR/L19	50	47	350	56	35	63	

Spare parts

Designation	Lever	Screw	Shim	Shim pin	Snap ring	Wrench		
S25T...12	LCL 4B	LCS 4B	-	-	LSR 4B	L-W 2.5		
S32T...12	LCL 4	LCS 4S	LSS 42	LSP 4	-	L-W 3		
S40T...12	LCL 4	LCS 4	LSS 42	LSP 4	-	L-W 3		
...19	LCL 6	LCS 6	LSS 63	LSP 6	-	L-W 4		

Screw type boring bars

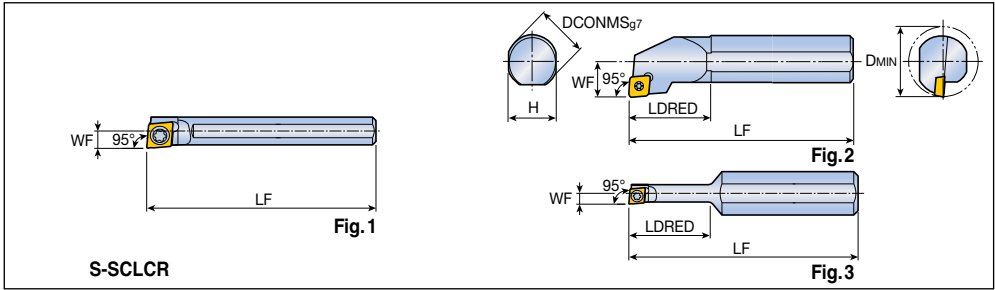

Approach angle	Designation	Dimension (mm)							Fig.	Insert
		DCONMS	H	LF	LDRED	WF	DMIN			
95°	S04F SCLCR/L 03-D05	4	3.75	80	-	2.5	5	1	CC...T 0301... A260-A263, A310	
	S05G SCLCR/L 03-D06	5	4.75	90	-	3	6	1		
	S10H SCLCR/L 03-D05	10	9	100	15	2.5	5	3		
	S06H SCLCR/L 04-D07	6	5.5	100	-	3.5	7	1	CC...T 0401...	
	S07J SCLCR/L 04-D08	7	6.5	110	-	4	8	1		
	S08K SCLCR/L 06	8	7	125	18	6	11	2	CC... 0602...	
	S10K SCLCR/L 06	10	9	125	20	7	13	2		
	S12M SCLCR/L 06	12	11	150	25	9	16	2		
	S16R SCLCR/L 06	16	15	200	30	11	20	2		
	S12M SCLCR/L 09	12	11	150	23	9	16	2	CC... 09T3...	
	S16R SCLCR/L 09	16	15	200	30	11	20	2		
	S20S SCLCR/L 09	20	18	250	32	13	25	2		
	S25T SCLCR/L 12	25	23	300	42	17	32	2	CC... 1204...	
	S32T SCLCR/L 12	32	30	300	45	22	40	2		
	S40T SCLCR/L 12	40	37	300	55	27	50	2		

▶ L-hand insert for R-hand toolholder, R-hand insert for L-hand toolholder

Spare parts

Designation	Screw	Shim	Shim screw	Wrench			
...03	TS 160311	-	-	T 6	-		
...04	TS 20038I/HG-P	-	-	T 6P	-		
S...K ...06	SO 25050I	-	-	T 7	-		
...06	SO 25065I	-	-	T 7	-		
...09	SO 35080I	-	-	T 15	-		
S25T...12	SO 45100I	-	-	T 20	-		
...12	SO 45130I	SSC 43N	SO 60105S	T 20	L-W 5		

C-SCLCR/L E-SCLCR/L



Screw type boring bars

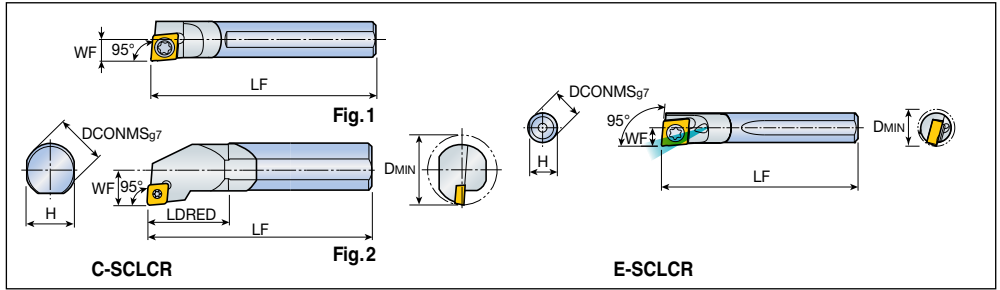

Approach angle	Designation	Dimension (mm)							Fig.	Insert
		DCONMS	H	LF	LDRED	WF	DMIN			
 95°	✓ C04G SCLCR/L 03-D05	4	3.75	90	-	2.5	5	1	CC...T 0301...	
	✓ C05H SCLCR/L 03-D06	5	4.75	100	-	3	6	1	A260-A263, A310	
	✓ C06J SCLCR/L 04-D07	6	5.5	110	-	3.5	7	1	CC...T 0401...	
	✓ C07K SCLCR/L 04-D08	7	6.5	125	-	4	8	1		
	✓ C08K SCLCR/L 06	8	7	125	15	6	11	2	CC... 0602...	
	✓ C10K SCLCR/L 06	10	9	125	15	7	13	2		
	✓ C12M SCLCR/L 06	12	11	150	18	9	16	2		
	✓ C12M SCLCR/L 09	12	11	150	18	9	16	2	CC... 09T3...	
	✓ C16R SCLCR/L 09	16	15	200	25	11	20	2		
✓ C20S SCLCR/L 09	20	18	250	25	13	25	2			
 95°	✓ E04G SCLCR/L 03-D05	4	3.75	90	-	2.5	5	-	CC...T 0301...	
	✓ E05H SCLCR/L 03-D06	5	4.75	100	-	3	6	-		
	✓ E06J SCLCR/L 04-D07	6	5.5	110	-	3.5	7	-	CC...T 0401...	
	✓ E07K SCLCR/L 04-D08	7	6.5	125	-	4	8	-		

▶ ✓: Designates carbide shank ▶ L-hand insert for R-hand toolholder, R-hand insert for L-hand toolholder

Spare parts

Designation	Screw	Wrench				
...03	TS 16031I	T 6				
...04	TS 20038I/HG-P	T 6P				
C08/C10...06	SO 25050I	T 7				
C12 ...06	SO 25065I	T 7				
...09	SO 35080I	T 15				

S-SCLPR/L A-SCLPR/L



Screw type boring bars

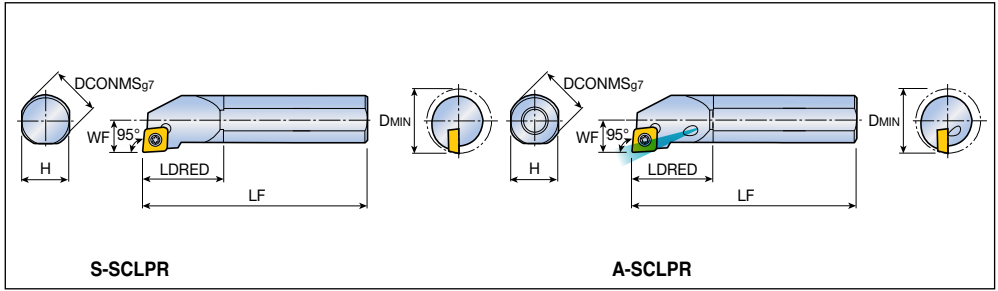

Approach angle	Designation	Dimension (mm)						Insert
		DCONMS	H	LF	LDRED	WF	DMIN	
95°	S10K SCLPR/L 08	10	9	125	20	6	12	CP...T 0802... A264
	S12M SCLPR/L 08	12	11	150	23	8	16	
	S16R SCLPR/L 09	16	15	200	30	10	20	
	S20S SCLPR/L 09	20	18	250	32	12.5	25	
95°	A08H SCLPR/L 06	8	7	100	15	6	11	CP...T 0602...
	A10K SCLPR/L 06	10	9	125	15	7	13	CP...T 0903...
	A12M SCLPR/L 0903	12	11	150	19	9	16	
	A16Q SCLPR/L 0903	16	15	180	20	11	20	CP...T 09T3...
	A20R SCLPR/L 0903	20	18	200	22	13	25	
	A12M SCLPR/L 09T3	12	11	150	19	9	16	
	A16Q SCLPR/L 09T3	16	15	180	24.5	11	20	
		A20R SCLPR/L 09T3	20	18	200	22	13	25

▶ L-hand insert for R-hand toolholder, R-hand insert for L-hand toolholder

Spare parts

Designation	Screw	Wrench					
...06	SO 25050I	T 7					
...08	SO 30055I	T 9					
...09	SO 35080I	T 15					
...0903, 09T3	TS 35070I/HG	T 15					

E-SCLPR/L A-SDLNR/L





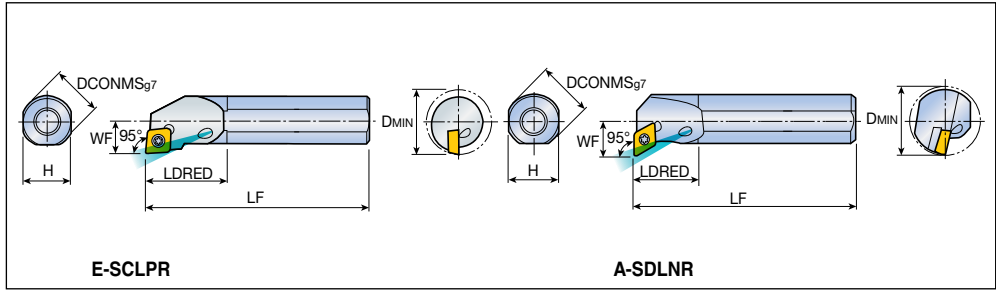

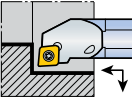
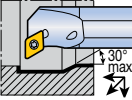

Screw type boring bars



Approach angle	Designation	Dimension (mm)						Insert
		DCONMS	H	LF	LDRED	WF	DMIN	
 95°	✓ E08K SCLPR/L 06	8	7	125	15	6	11	CP...T 0602... A264
	✓ E10K SCLPR/L 06	10	9	125	15	7	13	
	✓ E12M SCLPR/L 0903	12	11	150	19	9	16	CP...T 0903...
	✓ E16R SCLPR/L 0903	16	15	200	22	11	20	CP...T 09T3...
	✓ E12M SCLPR/L 09T3	12	11	150	19	9	16	
	✓ E16R SCLPR/L 09T3	16	15	200	22	11	20	
 30° max.	A20S SDLNR/L 11	20	18	250	28	13	24	DN...1104... A234-A235, A237
	A25T SDLNR/L 11	25	23	300	42	17	31	

▶ ✓: Designates carbide shank ▶ L-hand insert for R-hand toolholder, R-hand insert for L-hand toolholder

Spare parts

Designation	Screw	Shim	Shim screw	Wrench		Seal		
								
...06	SO 25050I	-	-	T 7	-	-		
...09	TS 35070I/HG	-	-	T 15	-	-		
A20S...11	SO 35120I	-	-	T 10	-	PL 20		
A25T ...11	SO 35120I	SSD 32	SO 50090S	T 10	L-W 3.5	PL 25		

S-SDQCR/L A-SDQNR/L



Screw type boring bars

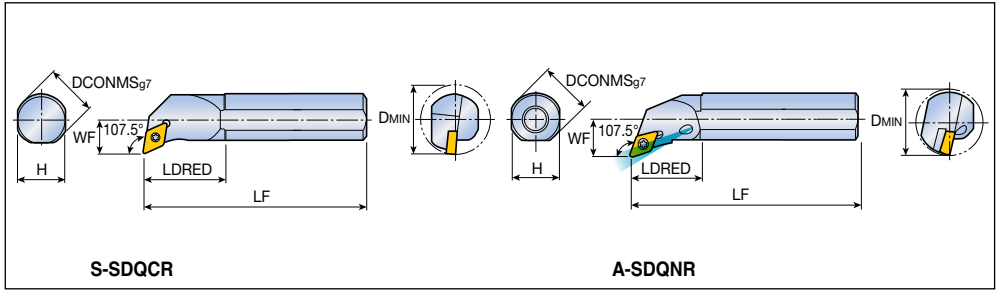

Approach angle	Designation	Dimension (mm)						Insert
		DCONMS	H	LF	LDRED	WF	DMIN	
107.5° 	S10K SDQCR/L 07	10	9	125	20	7	13	DC... 0702... A265-A268, A311
	S12M SDQCR/L 07	12	11	150	22	9	16	
	S16R SDQCR/L 07	16	15	200	27	11	20	DC... 11T3...
	S20S SDQCR/L 11	20	18	250	40	13	25	
	S25T SDQCR/L 11	25	23	300	50	17	32	
107.5° 	A16S SDQNR/L 11	16	15	250	30	13	23	DN... 1104... A234-A237
	A20S SDQNR/L 11	20	18	250	31	15	27	
	A25T SDQNR/L 11	25	23	300	35	19	33	
	A32T SDQNR/L 11	32	30	300	44	26	44	

▶ L-hand insert for R-hand toolholder, R-hand insert for L-hand toolholder

Spare parts





Designation	Screw	Shim	Shim screw	Wrench		Seal		
S10 ...07	SO 25050I	-	-	T 7	-	-		
S ...07	SO 25065I	-	-	T 7	-	-		
S ...11	SO 35080I	-	-	T 15	-	-		
A16S...11	SO 35120I	-	-	T 10	-	PL 16		
A20S...11	SO 35120I	SSD 32	SO 50090S	T 10	L-W 3.5	PL 20		
A25T ...11	SO 35120I	SSD 32	SO 50090S	T 10	L-W 3.5	PL 25		
A32T ...11	SO 35120I	SSD 32	SO 50090S	T 10	L-W 3.5	PL 32		

S-SDUCR/L A-SDUNR/L

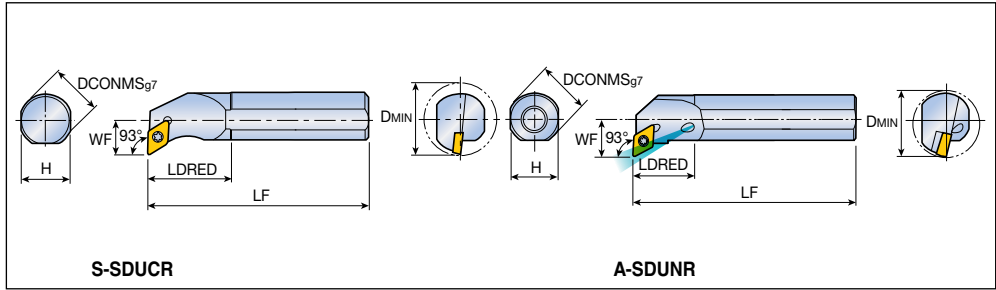

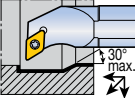

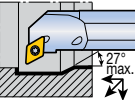



Screw type boring bars



Approach angle	Designation	Dimension (mm)						Insert
		DCONMS	H	LF	LDRED	WF	DMIN	
 93°	S10K SDUCR/L 07	10	9	125	20	7	13	DC... 0702...  A265-A268, A311 DC... 11T3...
	S12M SDUCR/L 07	12	11	150	23	9	16	
	S16R SDUCR/L 07	16	15	200	30	11	20	
	S16R SDUCR/L 11	16	15	200	27	11	20	
	S20S SDUCR/L 11	20	18	250	32	13	25	
	S25T SDUCR/L 11	25	23	300	42	17	32	
	S32T SDUCR/L 11	32	30	300	55	22	40	
 27° max.	A20S SDUNR/L 11	20	18	250	30	15	27	DN... 1104...  A234-A237
	A25T SDUNR/L 11	25	23	300	30	19	33	
	A32T SDUNR/L 11	32	30	300	44	26	44	

► L-hand insert for R-hand toolholder, R-hand insert for L-hand toolholder

Spare parts

Designation	Screw	Shim	Shim screw	Wrench		Seal		
								
S ...07	SO 25065I	-	-	T 7	-	-		
S ...11	SO 35080I	-	-	T 15	-	-		
A20S...11	SO 35120I	-	-	T 10	-	PL 20		
A25T ...11	SO 35120I	SSD 32	SO 50090S	T 10	L-W 3.5	PL 25		
A32T ...11	SO 35120I	SSD 32	SO 50090S	T 10	L-W 3.5	PL 32		

S-STFCR/L C-STFCR/L



Screw type boring bars

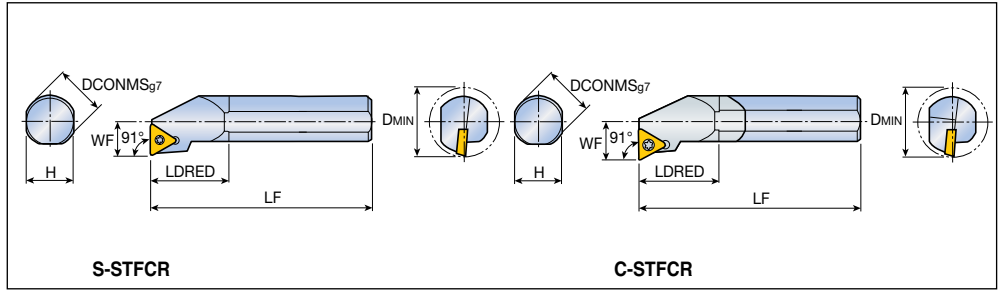

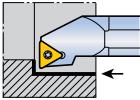
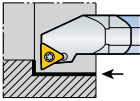
Approach angle	Designation	Dimension (mm)						Insert
		DCONMS	H	LF	LDRED	WF	DMIN	
91° 	S06H STFCR/L 06T1	6	5.4	100	12	4.5	8	TC...T 06T1...
	S08K STFCR/L 09	8	7	125	20	5	10	TC... 0902... A275, A276, A313, A314
	S10K STFCR/L 09	10	9	125	22.5	6	12	
	S12M STFCR/L 09	12	11	150	30	9	16	
	S16R STFCR/L 09	16	15	200	35	11	20	
	S10K STFCR/L 1102	10	9	125	17.7	6	12	TC...T 1102...
	S12M STFCR/L 1102	12	11	150	25	9	16	
	S16R STFCR/L 1102	16	15	200	35	11	20	
	S20S STFCR/L 1102	20	18	250	36	13	25	
	S20S STFCR/L 16	20	18	250	36	13	25	TC... 16T3...
	S25T STFCR/L 16	25	23	300	49	17	32	
	S32T STFCR/L 16	32	30	300	45	22	40	
	S40T STFCR/L 16	40	37	300	60	27	50	
91° 	✓ C10K STFCR/L 09	10	9	125	15	7	13	TC... 0902...
	✓ C10K STFCR/L 1102	10	9	125	15	7	13	TC...T 1102...
	✓ C12M STFCR/L 1102	12	11	150	20	9	16	
	✓ C16R STFCR/L 1102	16	15	200	25	11	20	

▶ ✓: Designates carbide shank ▶ L-hand insert for R-hand toolholder, R-hand insert for L-hand toolholder

Spare parts

Designation	Screw	Shim	Shim screw	Wrench			
...06T1	TS 20038I	-	-	T 6	-		
S08K...09	TS 22046I	-	-	T 7	-		
...09	SO 22050I	-	-	T 7	-		
S10K...1102	SO 22050I	-	-	T 7	-		
...1102	SO 25065I	-	-	T 7	-		
S20S...16	SO 35080I	-	-	T 15	-		
S25T...16	SO 35080I	-	-	T 15	-		
S32T...16	SO 35124I	SST 32	SO 50090S	T 15	L-W 3.5		
S40T...16	SO 35124I	SST 32	SO 50090S	T 15	L-W 3.5		

S-STFPR/L A-STFPR/L



Screw type boring bars

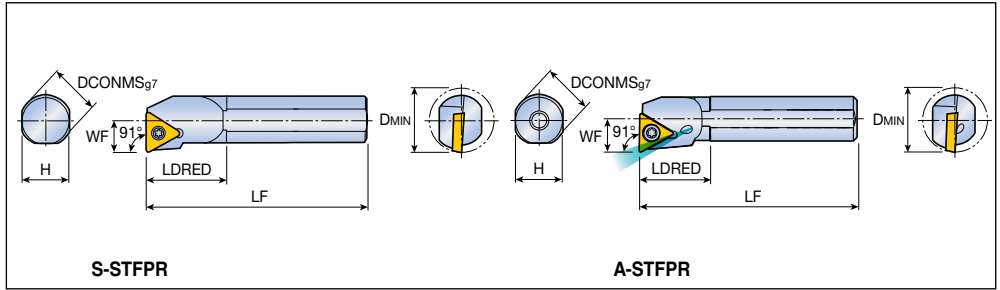

Approach angle	Designation	Dimension (mm)						Insert
		DCONMS	H	LF	LDRED	WF	DMIN	
91° 	S08K STFPR/L 09-X01	8	7	125	15	5	10	TPGX 0902...
	S08K STFPR/L 09	8	7	125	14	5	10	TP...T 0902...
	S10K STFPR/L 1103	10	9	125	25	6	12	TP... 1103... A277-A280,
	S12M STFPR/L 1103	12	11	150	30	8	16	A302,
	S16R STFPR/L 1103	16	15	200	35	10	20	A313-A314
	S16Q STFPR/L 1103	16	15	180	30	10	20	
	S16N STFPR/L 16	16	15	160	30	10	20	TP...T 1604...
	S20S STFPR/L 16	20	18	250	36	12.5	25	
91° 	A08H STFPR/L 09	8	7	100	16.7	6	11	TP...T 0902...
	A10K STFPR/L 1102	10	9	125	16.4	6	12	TP...T 1102...
	A12M STFPR/L 1102	12	11	150	19	9	16	
	A16Q STFPR/L 1102	16	15	180	20	11	20	
	A12M STFPR/L 1103	12	11	150	19	9	16	TP... 1103...
	A16Q STFPR/L 1103	16	15	180	20.5	11	20	
	A20R STFPR/L 16T3	20	18	200	26	13	25	TP...T 16T3...

► L-hand insert for R-hand toolholder, R-hand insert for L-hand toolholder

Spare parts



Designation	Screw 	Wrench 				
...09-X01	SO 25055I-MO	T 8				
...09	TS 22046I	T 7				
S10 ...1103	SO 30055I	T 9				
S12 ...1103	SO 30100I	T 9				
S16 ...1103	SO 30040I	T 9				
A ...1102	SO 25050I	T 7				
A ...1103	SO 30100I	T 9				
...16T3	TS 35070I/HG	T 15				
...16	SO 35124I	T 15				

C-STFPR/L E-STFPR/L



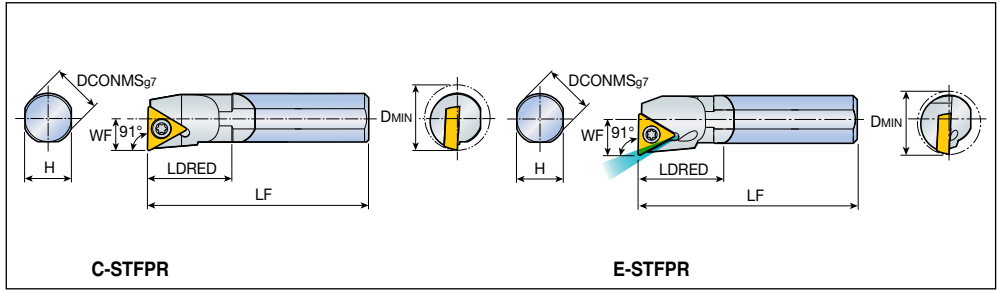

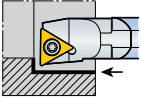
Screw type boring bars

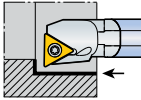

Approach angle	Designation	Dimension (mm)						Insert
		DCONMS	H	LF	LDRED	WF	DMIN	
 91°	✓ C10K STFPR/L 1103	10	9	125	15	6	12	TP... 1103...  A277-A280, TP...T 1103... A302, A313-A314
	✓ C10M STFPR/L 1103	12	11	150	20	8	16	
	✓ C12M STFPR/L 11-FF	10	9	125	15	6	12	
	✓ C12M STFPR/L 11-FF	12	11	150	18	8	16	
 91°	✓ E08K STFPR/L 09	8	7	125	15	6	11	TP...T 0902...
	✓ E10K STFPR/L 1102	10	9	125	15	7	13	TP...T 1102...
	✓ E12M STFPR/L 1102	12	11	150	18	9	16	
	✓ E16R STFPR/L 1102	16	15	200	21.5	11	20	
	✓ E12M STFPR/L 1103	12	11	150	18	9	16	TP... 1103...
	✓ E16R STFPR/L 1103	16	15	200	22	11	20	

- ▶ ✓: Designates carbide shank ▶ L-hand insert for R-hand toolholder, R-hand insert for L-hand toolholder
- ▶ Only -FF/-GF inserts available for 11 size holders

Spare parts

Designation	Screw	Wrench				
	...09	 TS 22046I	 T 7			
C ...11-FF	SO 25065I	T 7				
C10K ...1103	SO 30055I	T 9				
C12M ...1103	SO 30100I	T 9				
E ...1102	SO 25050I	T 7				
E ...1103	SO 30100I	T 9				

C-STZBR/L



Screw type boring bars

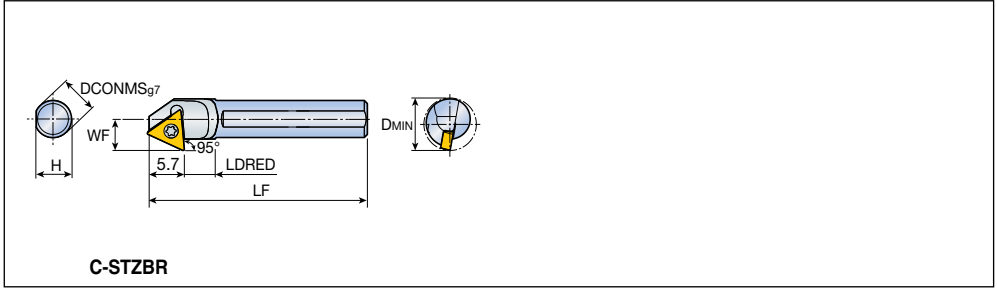

Approach angle	Designation	Dimension (mm)							Insert
		DCONMS	H	LF	LDRED	WF	DMIN		
95°	✓ C06J STZBR/L 06-D085	6	5.5	110	5	5.1	8.5	TB...T 0601... A274	

▶ ✓: Designates carbide shank

Spare parts

Designation	Screw	Wrench					
...06-D085	SO 250431	T 6P					

S-SVJBR/L S-SVJCR/L



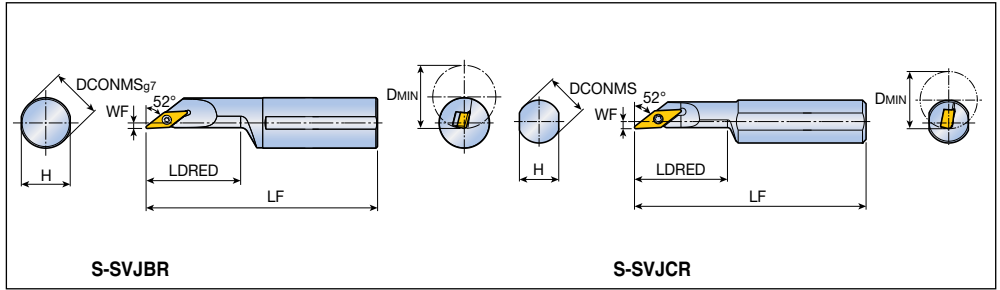

Screw type boring bars

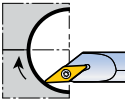
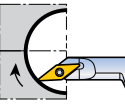

Approach angle	Designation	Dimension (mm)						Insert
		DCONMS	H	LF	LDRED	WF	DMIN	
52° 	S20R SVJBR/L 11-D25	20	18	200	37.5	2	25	VB... 1103... A281, A282, VB... 1604... A315
	S25S SVJBR/L 11-D30	25	23	250	45	3.5	30	
	S32S SVJBR/L 16	32	30	250	60	3.5	40	
	S40T SVJBR/L 16	40	37	300	75	4.5	50	
52° 	S12M SVJCR/L 08-D16	12	11	150	26	2	16	VC... 0802... A284
	S16Q SVJCR/L 08-D20	16	15	180	36	2	20	

► L-hand insert for R-hand toolholder, R-hand insert for L-hand toolholder

Spare parts

Designation	Screw	Shim	Shim screw	Wrench			
							
...08-...	TS 20038I/HG-P	-	-	T 6P	-		
...11-...	SO 25065I	-	-	T 7	-		
...16	SO 35124I	SSV32	SO 50090S	T15	L-W 3.5		

S-SVJPR/L A-SVLNR/L



Screw type boring bars

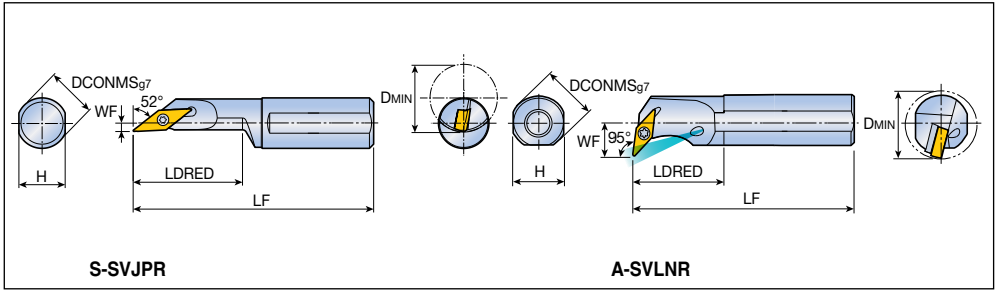

Approach angle	Designation	Dimension (mm)						Insert
		DCONMS	H	LF	LDRED	WF	DMIN	
52°	S12M SVJPR/L 08-D16	12	11	150	26	2	16	VP...T 0802... A285
95°	A25T SVLNR/L 13 A32T SVLNR/L 13	25 32	23 30	300 300	40 45	16 20	31 38	VN... 13... A251-A252

▶ L-hand insert for R-hand toolholder, R-hand insert for L-hand toolholder

Spare parts

Designation	Screw	Shim	Shim screw	Wrench		Seal		
S...08-D16	TS 20043I/HG-P	-	-	T 6P	-	-		
A25T...13	SO 35120I	SSVN 2.523	TS 5035062S	T 10	L-W 3.5	PL 25		
A32T...13	SO 35120I	SSVN 2.523	TS 5035062S	T 10	L-W 3.5	PL 32		

S-SVPBR/L S-SVPCR/L



Screw type boring bars

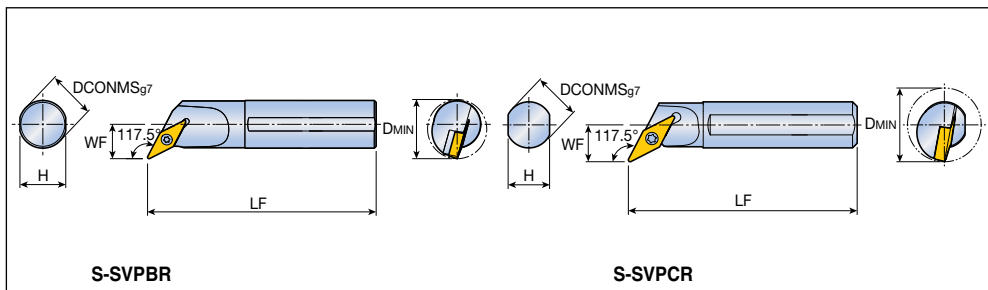

Approach angle	Designation	Dimension (mm)						Insert
		DCONMS	H	LF	LDRED	WF	DMIN	
 117.5°	S16Q SVPBR/L 11-D22	16	15	180	35	13.5	22	VB... 1103...
	S20R SVPBR/L 11-D26	20	18	200	41	15.5	26	A281-A282,
	S25S SVPBR/L 16	25	23	250	51	18	31	A315
	S32S SVPBR/L 16	32	30	250	54	23	40	
 117.5°	S10K SVPCR/L 08-D16	10	9	125	16	8	16	VC...T 0802...
	S12M SVPCR/L 11-D20	12	11	150	19	10	20	VC...T 1103...
								A283-A284,
								A315

► L-hand insert for R-hand toolholder, R-hand insert for L-hand toolholder

Spare parts

Designation	Screw	Shim	Shim screw	Wrench			
...08-...	TS 20038I/HG-P	-	-	T 6P	-		
...11-...	SO 25065I	-	-	T 7	-		
...16	SO 35124I	SSV32	SO 50090S	T 15	L-W 3.5		

A-SVPCR/L A-SXUNR/L



Screw type boring bars

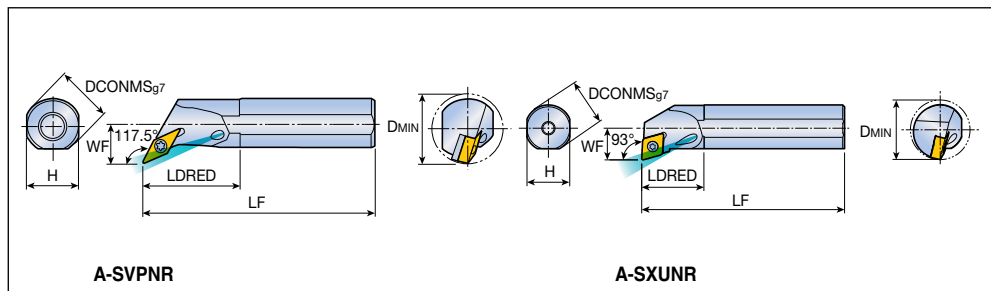

Approach angle	Designation	Dimension (mm)						Insert
		DCONMS	H	LF	LDRED	WF	DMIN	
117.5°	A25T SVPNR/L 13	25	23	300	45	19	33	VN... 13... A251-A252
	A32T SVPNR/L 13	32	30	300	47	26	44	
93°	A25R SXUNR/L 1105	25	23	200	33.4	17	32	XN... 1105... A257

Spare parts





Designation	Screw	Shim	Shim screw	Wrench		Seal		
...1105	TS 40G110I	-	-	T 15	-	-		
A25T...13	SO 35120I	SSVN 2.523	TS 5035062S	T 10	L-W 3.5	PL 25		
A32T...13	SO 35120I	SSVN 2.523	TS 5035062S	T 10	L-W 3.5	PL 32		

S-SVQBR/L S-SVQCR/L

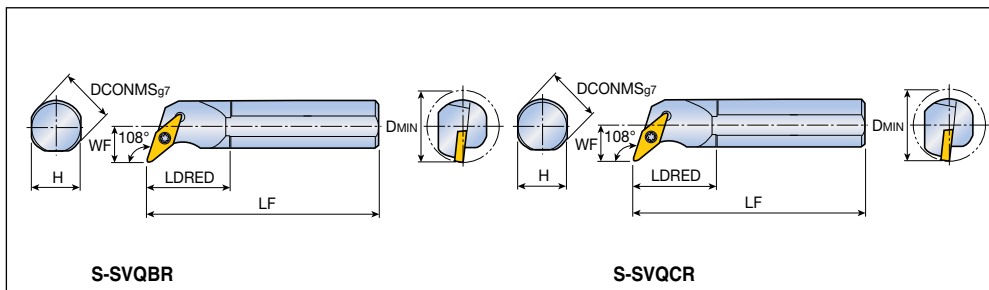

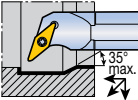
Screw type boring bars

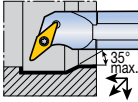

Approach angle	Designation	Dimension (mm)						Insert
		DCONMS	H	LF	LDRED	WF	DMIN	
108° 	S25T SVQBR/L 16	25	23	300	40	17	32	VB... 1604...  A281-A282, A315
	S32T SVQBR/L 16	32	30	300	45	22	40	
	S40T SVQBR/L 16	40	37	300	41.5	27	50	
108° 	S32T SVQCR/L 16	32	30	300	45	22	40	VC...T 1604...  A283-A284, A315
	S40T SVQCR/L 16	40	37	300	55	27	50	

▶ L-hand insert for R-hand toolholder, R-hand insert for L-hand toolholder

Spare parts

Designation	Screw	Shim	Shim screw	Wrench			
							
S25T...16	SO 35080I	-	-	T 15	-		
...16	SO 35124I	SSV 32	SO 50090S	T 15	L-W 3.5		

S-SVUBR/L S-SVUCR/L



Screw type boring bars

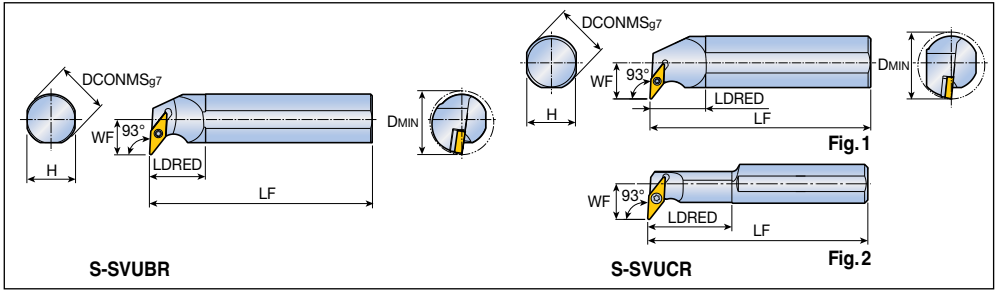

Approach angle	Designation	Dimension (mm)						Fig.	Insert	
		DCONMS	H	LF	LDRED	WF	DMIN			
93°	S32T SVUBR/L 16	32	30	300	45	22	40	VB... 1604...	 A281-A282, A315	
	S40T SVUBR/L 16	40	37	300	55	27	50			
93°	S12M SVUCR/L 08-D16	12	11	150	26	11	16	2	VC...T 0802...	 A283-A284, A315
	S16Q SVUCR/L 11-D20	16	15	180	32	15.5	20	2	VC...T 1103...	
	S20R SVUCR/L 11-D25	20	18	200	40	17.5	25	2		
	S32T SVUCR/L 16	32	30	300	35	22	40	1	VC...T 1604...	
	S40T SVUCR/L 16	40	37	300	41.5	27	50	1		

▶ L-hand insert for R-hand toolholder, R-hand insert for L-hand toolholder

Spare parts

Designation	Screw	Shim	Shim screw	Wrench				
...08-...	TS 20038I/HG-P	-	-	T 6P	-			
...11-...	SO 25065I	-	-	T 7	-			
...16	SO 35124I	SSV 32	SO 50090S	T 15	L-W 3.5			

Screw type boring bars

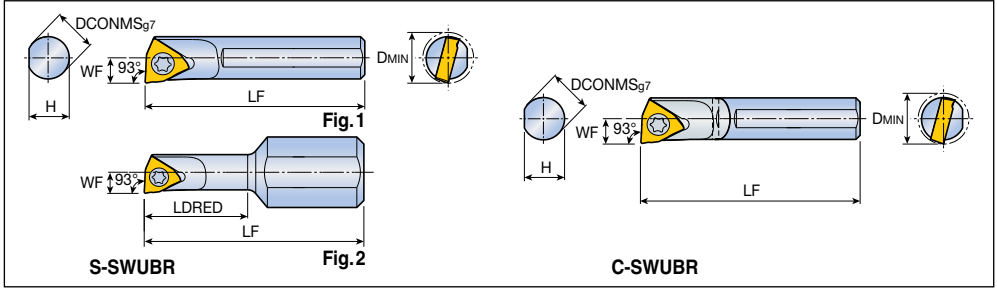

Approach angle	Designation	Dimension (mm)						Fig.	Insert
		DCONMS	H	LF	LDRED	WF	DMIN		
 93°	S05G SWUBR/L 06-D06	5	4.75	90	-	3	6	1	WB...T 0601... A286
	S06H SWUBR/L 06-D07	6	5.5	100	-	3.5	7	1	
	S07J SWUBR/L 06-D08	7	6.5	110	-	4	8	1	
	S10H SWUBR/L 06-D06	10	9	100	18	3	6	2	
 93°	✓ C05H SWUBR/L 06-D06	5	4.75	100	-	3	6		
	✓ C06J SWUBR/L 06-D07	6	5.5	110	-	3.5	7		
	✓ C07K SWUBR/L 06-D08	7	6.5	125	-	4	8		

▶ ✓: Designates carbide shank ▶ L-hand insert for R-hand toolholder, R-hand insert for L-hand toolholder

Spare parts

Designation	Screw	Wrench						
	...06-...	TS 20038/HG-P	T 6P					

T-holder type boring bars

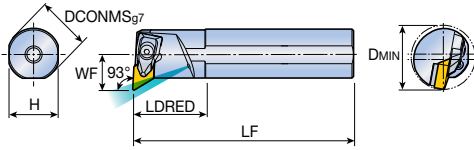

A-TDUNR

Approach angle	Designation	Dimension (mm)						Insert
		DCONMS	H	LF	LDRED	WF	DMIN	
93°	A32T TDUNR/L 15	32	30	300	45	22	40	DN... 1506... A234-A238, A293, A304
	A40T TDUNR/L 15	40	37	300	45	27	50	
	A50U TDUNR/L 15	50	47	350	45	35	63	

Spare parts

Designation	Clamp	Clamp screw	Spring	Shim	Shim screw	Nozzle	Wrench	
A32T ...15	DLM 4	DLS 4	DSP 4	LSD 42	TS 50A105I	NZ 62	L-W 3	T 20
...15	DLM 4	DLS 4	DSP 4	TSD 43	SO 40050I	NZ 104	L-W 3	T 15

T-holder type boring bars

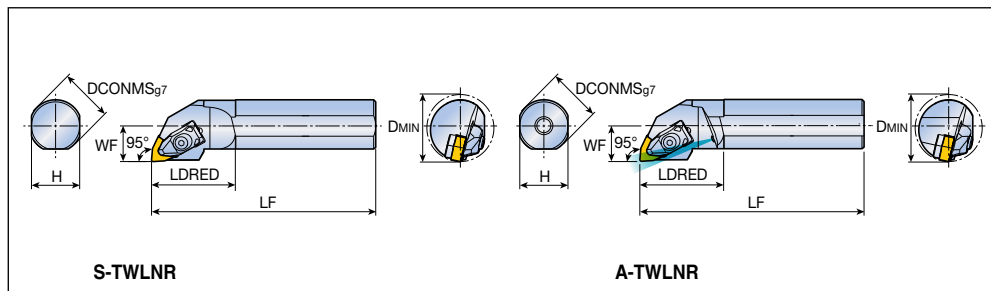

Approach angle	Designation	Dimension (mm)						Insert
		DCONMS	H	LF	LDRED	WF	DMIN	
95°	S25T TWLNR/L 08	25	23	300	35	17	32	WN... 0804... A253-A255, A300, A309
	S32T TWLNR/L 08	32	30	300	45	22	40	
95°	A20S TWLNR/L 06	20	18	250	35	13	25	WN... 0604...
	A25T TWLNR/L 06	25	23	300	40	17	32	
	A32T TWLNR/L 06	32	30	300	45	22	40	
	A25T TWLNR/L 08	25	23	300	40	17	32	WN... 0804...
	A32T TWLNR/L 08	32	30	300	45	22	40	
	A40T TWLNR/L 08	40	37	300	45	27	50	

Spare parts

Designation	Clamp	Clamp screw	Spring	Shim	Shim screw	Nozzle	Wrench	
A20S...06	DLM 3	DLS 3	DSP 3	-	-	NZ 62	L-W 2.5	-
...06	DLM 3	DLS 3	DSP 3	PSW 32	SO 400901	NZ 62	L-W 2.5	T 15
...08	DLM 4	DLS 4	DSP 4	PSW 42	TS 50A1051	NZ 62	L-W 3	T 20
A40T...08	DLM 4	DLS 4	DSP 4	TSW 44	SO 400501	NZ 104	L-W 3	T 15

Wedge clamp type boring bars

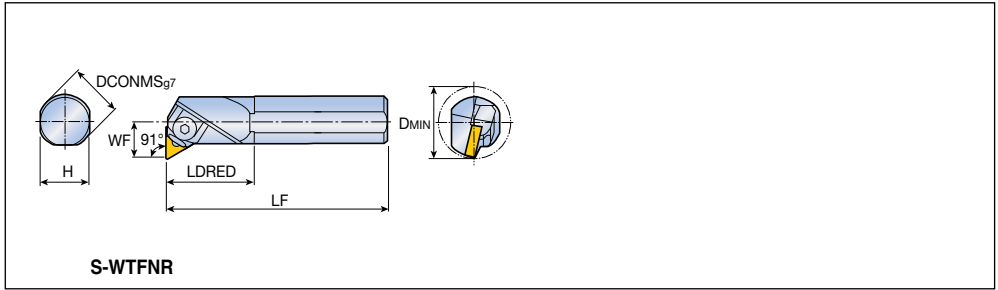

Approach angle	Designation	Dimension (mm)						Insert
		DCONMS	H	LF	LDRED	WF	DMIN	
91°	S25T WTFNR/L 16	25	23	300	50	17	32	TN... 1604... A247-A250, A299, A307
	S32T WTFNR/L 16	32	30	300	55	22	40	
	S40T WTFNR/L 16	40	37	300	60	27	50	
	S40T WTFNR/L 22	40	37	300	60	27	50	
	S50U WTFNR/L 22	50	47	350	65	35	63	

Spare parts

Designation	Wedge clamp	Screw	Snap ring	Shim	Pin screw	Wrench	
S25T ...16	WC 33	WCS 4B	WSR 4	-	WSS 33-1	L-W 3	
...16	WC 33	WCS 4	WSR 4	WST 33	WSS 33	L-W 3	
...22	WC 43	WCS 4	WSR 4	WST 43	WSS 43	L-W 3	

QH-PCLNR/L QH-PDUNR/L



Screw type boring heads

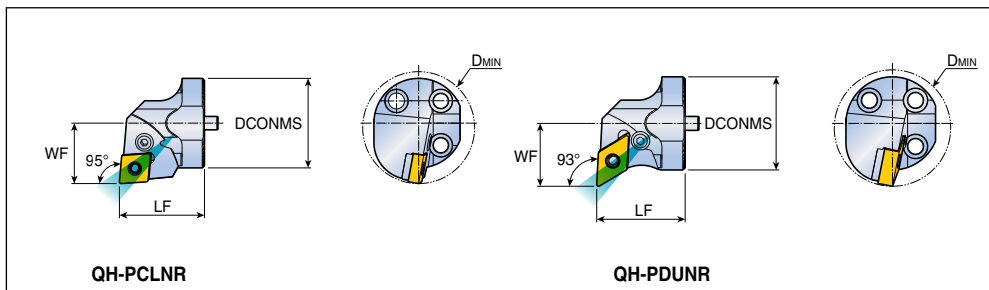

Approach angle	Designation	Dimension (mm)				Insert	
		DCONMS	LF	WF	DMIN		
95°	QH32-PCLNR/L-12	32	32	22	40	CN... 1204... A226, A228-A232, A233, A291, A292, A303	
	QH40-PCLNR/L-12 *	40	38	27	50		
93°	QH40-PDUNR/L-1506 *	40	38	27	50		DN... 1506... A234-A238, A293, A354

► *: When applying Ø50mm shank, DMIN for the assembly is Ø60mm
 When applying Ø60mm shank, DMIN for the assembly is Ø70mm

Spare parts

Designation	Lever	Screw	Shim	Shim pin	Wrench	
QH...12	LCL 4	LCS 4	LSC 42	-	LSP 4	L-W 3
QH...1506	LCL 4A	LCS 4	-	LSD 42	LSP 4	L-W 3

QH-TDUNR/L QH-TVUNR/L



Screw type boring heads

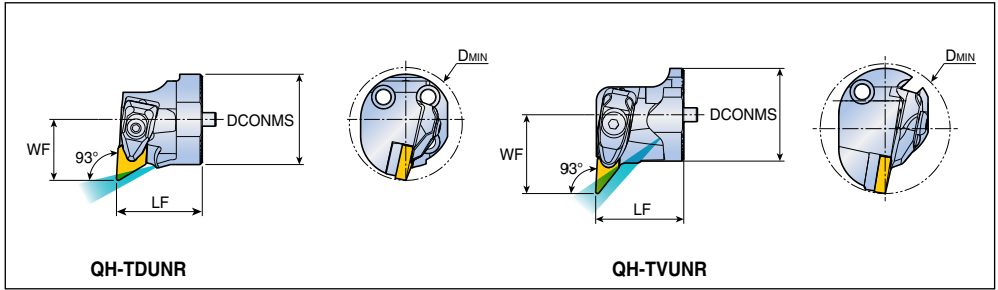

Approach angle	Designation	Dimension (mm)				Insert	
		DCONMS	LF	WF	DMIN		
93° 	QH40-TDUNR/L-1504 *	40	38	27	50	DN... 1504...	
	QH40-TDUNR/L-1506 *	40	38	27	50	DN... 1506...	
93° 	QH40-TVUNR/L-16 *	40	38	34	56	VN... 16...	

► *: When applying Ø50mm shank, DMIN for the assembly is Ø60mm
 When applying Ø60mm shank, DMIN for the assembly is Ø70mm

Spare parts

Designation	Clamp	Clamp screw	Spring	Shim		Shim screw	Wrench	
QH...1504	DLM 4	DLS 4	DSP 4	LSD 43	-	SO 50090I	L-W 3	T 20
QH...1506	DLM 4	DLS 4	DSP 4	LSD 42	-	TS 50A105I	L-W 3	T 20
QH...16	DLM 3V	DLS 5	DSP 5	-	TSV 33	SO 35080I	L-W 4	T 15

Anti-vibration shanks for boring

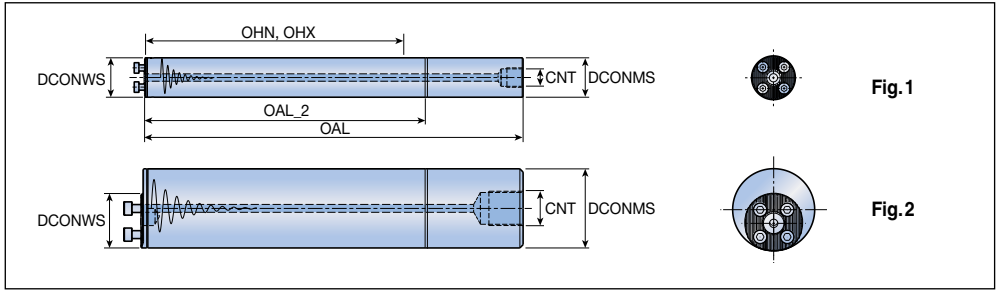

Designation	Dimension (mm)							Coolant hole	Fig.
	DCONMS	DCONWS	OAL	OAL_2	OHN	OHX	CNT		
QS16A-7D	16	16	156.3	100	55	92	G 1/8	●	1
QS16E-10D ⁽¹⁾	16	16	204.3	-	96	140	-	●	1
QS20A-7D	20	20	200.3	125	70	120	G 1/4	●	1
QS20E-10D ⁽¹⁾	20	20	260.3	-	120	180	-	●	1
QS25A-7D	25	25	257.5	155	88	155	G 1/4	●	1
QS25A-10D	25	25	332.5	255	155	230	G 1/4	●	1
QS25E-12D ⁽¹⁾	25	25	380.0	-	230	280	G 1/8	●	1
QS25E-14D ⁽¹⁾	25	25	430.0	-	280	330	G 1/8	●	1
QS32A-7D	32	32	323.0	190	120	192	G 3/8	●	1
QS32A-10D	32	32	419.0	320	192	288	G 3/8	●	1
QS32E-12D ⁽¹⁾	32	32	480.0	-	288	352	G 1/4	●	1
QS32E-14D ⁽¹⁾	32	32	544.0	-	352	416	G 1/4	●	1
QS40A-7D	40	40	411.0	240	128	251	G 1/2	●	1
QS40A-10D	40	40	531.0	410	248	368	G 1/2	●	1
QS40E-12D ⁽¹⁾	40	40	608.0	-	368	448	G 3/8	●	1
QS40E-14D ⁽¹⁾	40	40	688.0	-	448	528	G 3/8	●	1
QS50A-7D	50	40	523.0	305	168	318	G 1/2	●	2
QS50A-10D	50	40	673.0	520	318	468	G 1/2	●	2
QS50E-12D ⁽¹⁾	50	40	768.0	-	468	568	G 1/2	●	2
QS50E-14D ⁽¹⁾	50	40	868.0	-	568	668	G 1/2	●	2
QS60A-7D	60	40	633.0	380	208	388	G 3/4	●	2
QS60A-10D	60	40	813.0	630	388	568	G 3/4	●	2
QS60E-12D ⁽¹⁾	60	40	920.0	-	588	688	G 3/4	●	2
QS60E-14D ⁽¹⁾	60	40	1040.0	-	688	808	G 3/4	●	2

- ▶ ⁽¹⁾ Carbide shank
- ▶ OHN: Minimum overhang
- ▶ OHX: Maximum overhang
- ▶ OAL_2: Minimum length after shortening(only steel bar can be shortened)

Spare parts

Designation	Screw	Wrench					
QS16	SH M3x0.5X10	L-W 2.5					
QS20	SH M3.5x0.6X10	L-W 2.5					
QS25	SH M4x0.7X12	L-W 3					
QS32	SH M5x0.8X12	L-W 4					
QS40/50/60	SH M6x1X16	L-W 5					

QH-SET

Center height set up device for Anti-vibration boring bars

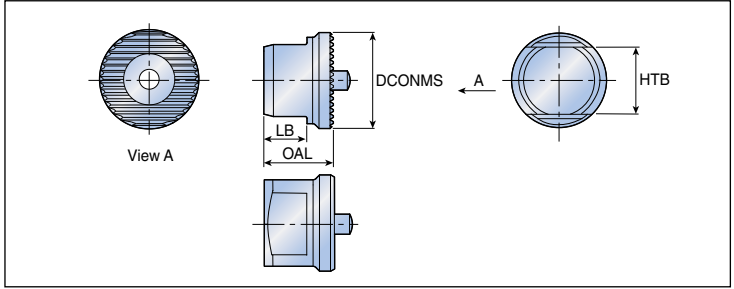

Designation	Dimension (mm)				
	DCONMS	HTB	OAL	LB	Shank
QH-SET 16-25	20	15	14.5	9	16, 20, 25
QH-SET 32-60	29	16	17.5	11.5	32, 40, 50, 60

QH-SET-LEV

Center height set up device for Anti-vibration boring bars

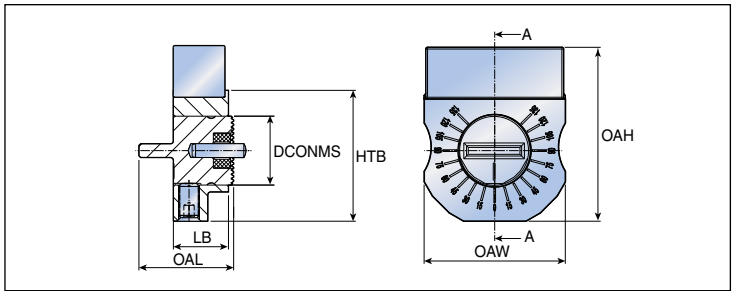

Designation	Dimension (mm)						
	DCONMS	HTB	OAL	LB	Shank	OAH	OAW
QH-SET 16-25-LEV	20	38	27.5	16	16, 20, 25	50.5	41
QH-SET 32-60-LEV	29	49	28.0	16	32, 40, 50, 60	59.0	49

C-ADAPTERs with HUSH-BORE head connection

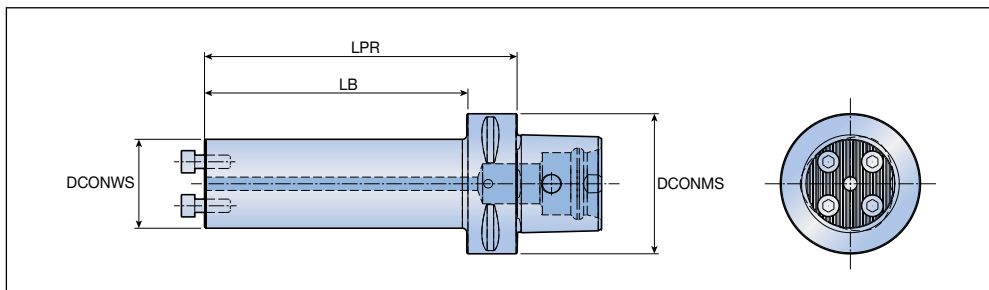

Designation	Dimension (mm)				Coolant hole
	DCONMS	DCONWS	LPR	LB	
C4-CS16A-2.5D	40	16	40	20	●
C4-CS20A-2.5D	40	20	50	30	●
C4-CS25A-2.5D	40	25	55	35	●
C4-CS32A-2.5D	40	32	75	55	●
C4-CS40A-3D	40	40	80	80	●
C5-CS16A-2.5D	50	16	40	20	●
C5-CS20A-2.5D	50	20	50	30	●
C5-CS25A-2.5D	50	25	55	35	●
C5-CS32A-2.5D	50	32	75	55	●
C5-CS40A-3D	50	40	100	80	●
C6-CS16A-2.5D	63	16	40	18	●
C6-CS20A-2.5D	63	20	50	28	●
C6-CS25A-2.5D	63	25	65	43	●
C6-CS32A-3D	63	32	90	68	●
C6-CS32A-4D	63	32	125	103	●
C6-CS40A-3D	63	40	100	78	●
C6-CS40A-4D	63	40	140	118	●
C6-CS16E-5D	63	16	80	58	●
C6-CS20E-5D	63	20	100	78	●
C6-CS25E-5D	63	25	115	93	●
C6-CS32E-5D	63	32	150	128	●
C6-CS40E-5D	63	40	185	163	●

► 5D: Carbide core type

Spare parts

Designation	Screw	Wrench			
CS16	SH M3x0.5X10	L-W 2.5			
CS20	SH M3.5x0.6X10	L-W 2.5			
CS25	SH M4x0.7X12	L-W 3			
CS32	SH M5x0.8X12	L-W 4			
CS40	SH M6x1X16	L-W 5			

► Please refer to A203-A212 pages for HUSH-BORE heads

Head changeable square shank

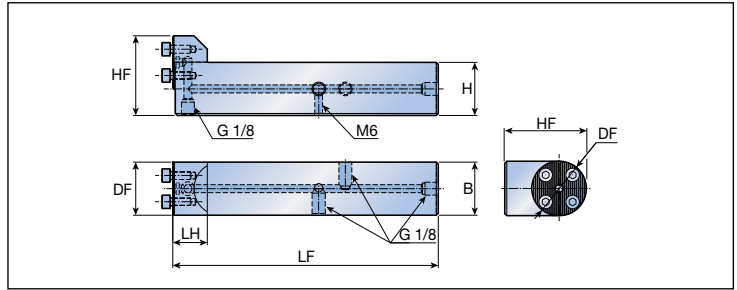

Designation	Dimension (mm)						Coolant hole
	B	H	LF	LH	HF	DF	
QSS- N2020-D20-TB-MC	20	20	92	21	30	20	●
N2020-D25-TB-MC	20	20	92	21	32.5	25	●
N2020-D32-TB-MC	20	20	92	21	36	32	●
N2525-D25-TB-MC	25	25	107	21	37.5	25	●
N2525-D32-TB-MC	25	25	107	21	41	32	●
N2525-D40-TB-MC	25	25	107	21	45	40	●
N3232-D32-TB-MC	32	32	152	21	48	32	●
N3232-D40-TB-MC	32	32	152	26	52	40	●
N4040-D40-TB-MC	40	40	200	26	60	40	●

Spare parts

Designation	Screw	Plug		Wrench	
...-D20...	SH M3.5x0.6X10	RSS M6	PLG G1/8-L6.5	L-W 2.5	
...-D25...	SH M4x0.7X12	RSS M6	PLG G1/8-L6.5	L-W 3	
...N2020/N2525-D32...	SH M5x0.8X12	RSS M6	PLG G1/8-L6.5	L-W 4	
...N3232-D32...	SH M5x0.8X12	-	PLG G1/8-L6.5	L-W 4	
...N2525-D40...	SH M6x1X16	RSS M6	PLG G1/8-L6.5	L-W 5	
...N3232/N4040-D40...	SH M6x1X16	-	PLG G1/8-L6.5	L-W 5	

► Please refer to A203-A212 pages for HUSH-BORE heads

Turning Inserts



C **N** **M** **G**

1 2 3 4

1 Shape

C	D	E	H	K	R	S	T	V	W	Y

2 Clearance angle

N	B	C	P

3 Tolerance

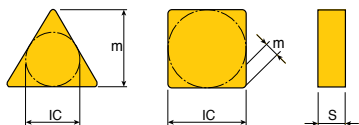

Class	m	S	IC
A	±0.005	±0.025	±0.025
F	±0.005	±0.025	±0.013
C	±0.013	±0.025	±0.025
H	±0.013	±0.025	±0.013
E	±0.025	±0.025	±0.025
G	±0.025	±0.13	±0.025
M	±0.08~±0.18	±0.13	±0.05~±0.13
U	±0.13~±0.38	±0.13	±0.08~±0.25

Diameter of IC	Tolerance			
	On m		On IC	
	Class M	Class U	Class M	Class U
6.35	±0.08	±0.13	±0.05	±0.08
9.52	±0.08	±0.13	±0.05	±0.08
12.70	±0.13	±0.20	±0.08	±0.13
15.88	±0.15	±0.27	±0.10	±0.18
19.05	±0.15	±0.27	±0.10	±0.18
25.40	±0.18	±0.38	±0.13	±0.25
31.75	±0.18	±0.38	±0.13	±0.25

4 Type

A	G	M	R	B, W	T, H

12 **04** **08** (**R**) **MP**

5 6 7 8 9

5 Cutting edge length

I.C(mm)	C	D	E	R	S	T	V,Y	W	K	H
3.97	03	04			03	06		02		
4.76	04	05			04	08	08			
5.56	05	06			05	09	09	03		
6.35	06	07			06	11	11			
7.94	08	09			07	13	13	05		
8.0				08						
9.52	09	11		09	09	16	16	06	16	
10.0				10						
11.11		13								
12.0				12						
12.7	12	15	13		12	22	22	08		05
15.88	16	19		15	15	27	27	10		
16.0				16						
19.05	19	23		19	19	33	33	13		10
20.0				20						
25.0				25						
25.4	25	31		25	25	44	44	17		
31.75	32	38			31	54	54	21		
32.0				32						

6 Thickness

01	1.59mm
T1	1.98mm
02	2.38mm
T2	2.78mm
03	3.18mm
T3	3.97mm
04	4.76mm
05	5.56mm
06	6.35mm
07	7.94mm
09	9.52mm

7 Corner radius

01	0.1mm
02	0.2mm
04	0.4mm
05	0.5mm
08	0.8mm
12	1.2mm
16	1.6mm
20	2.0mm
24	2.4mm
32	3.2mm

8 Hand of insert

R: Right hand	
L: Left hand	

9 Chip breaker

For chip breakers, see page A31-A42

Negative 80° rhombic inserts

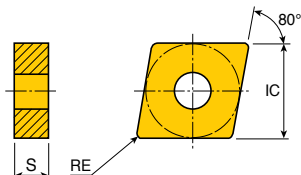

Size	Dimension (mm)		
	IC	S	RE
12	12.7	4.76	0.1-1.6
16	15.88	6.35	1.2-1.6
19	19.05	6.35	0.8-1.6

Insert	Designation	ap (mm)	Feed (mm/rev)	Coating																							
				Cermet		CVD coated										PVD coated											
				PV3010	CT3000	TT3005	TT7005	TT7015	TT7025	TT8105B	TT8125B	TT8135B	TT9215	TT9225	TT9235	TT15100	TT7100	TT5080	TT8020	TT9080	TT3010	TT3020	TT9020	K10			
 Medium	CNGG 120401 ML	0.1-3.5	0.03-0.10															●	●								
	120402 ML	0.2-3.5	0.05-0.15																●	●					●		
	120404 ML	0.8-3.5	0.10-0.30																●	●					●		
	120408 ML	1.0-3.5	0.12-0.35																●	●					●		
 Roughing	CNMA 120404	1.0-5.0	0.15-0.50				●	●	●																●		
	120408	1.0-6.0	0.15-0.60				●	●	●																●		
	120412	1.5-6.0	0.15-0.70				●	●	●	●																	
	120416	2.0-6.0	0.20-0.80				●	●	●																		
	160612	2.0-8.0	0.15-0.70				●	●	●																		
	160616	2.0-8.0	0.20-0.80					●																			
	190608	2.0-10.0	0.15-0.70						●																		
	190612	2.0-10.0	0.15-0.70						●	●																	
	190616	3.0-10.0	0.15-1.00					●	●	●																	
 Roughing	CNMA 120408 WT	0.7-5.0	0.15-0.80				●																				

A58-A59, A100-A101, A146,
A170, A194, A203, A205

● Standard items



Negative 80° rhombic inserts

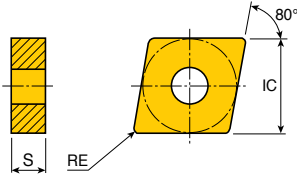

Size	Dimension (mm)		
	IC	S	RE
12	12.7	4.76	0.4-1.6
16	15.88	4.76	0.4-1.6
19	19.05	6.35	0.4-1.6

Insert	Designation	ap (mm)	Feed (mm/rev)	Cermat		CVD coated								PVD coated				K10					
				PV3010	CT3000	TT3005	TT7005	TT7015	TT7025	TT8105B	TT8115B	TT8125B	TT8135B	TT9215	TT9225	TT9235	TT15100		TT7100	TT5080	TT8020	TT9080	TT3010
	CNMG 120404	1.0-5.0	0.17-0.45				●	●		●	●	●		●			●						●
	120408	1.5-5.0	0.23-0.60				●	●	●	●	●	●		●			●	●					
	120412	2.0-5.0	0.25-0.60				●	●		●	●			●									
	160604	2.0-6.5	0.20-0.45								●												
	160608	2.0-6.5	0.25-0.60								●	●		●									
	160612	2.0-6.5	0.27-0.60								●												
	160616	2.0-6.5	0.29-0.60								●												
	190604	3.0-8.0	0.20-0.45								●	●			●								
	190608	3.0-8.0	0.25-0.60					●	●		●	●	●		●								
	190612	3.0-8.0	0.30-0.60					●	●		●	●	●		●	●							
190616	3.0-8.0	0.35-0.70								●	●	●		●									
	CNMG 120404 EA	0.15-1.5	0.05-0.30										●	●	●		●	●	●	●			
	120408 EA	0.15-1.5	0.07-0.40										●	●	●		●	●	●	●			
	CNMG 120404 EM	0.5-5.0	0.11-0.50										●	●	●		●	●					
	120408 EM	0.5-5.0	0.13-0.50										●	●	●		●	●					
	120412 EM	0.5-5.0	0.15-0.55										●	●	●		●	●					
	120416 EM	0.5-5.0	0.17-0.60										●				●						
	160608 EM	0.5-6.5	0.13-0.50														●						
	160612 EM	0.5-6.5	0.15-0.55														●						
	190608 EM	0.5-8.0	0.13-0.50														●						
	190612 EM	0.5-8.0	0.15-0.55												●		●	●					●
	190616 EM	0.5-8.0	0.17-0.60														●						
	CNMG 120408 ET	1.2-5.5	0.17-0.55										●	●	●		●	●	●	●			
	120412 ET	1.2-5.5	0.20-0.60										●	●	●		●	●	●	●			
	160608 ET	2.5-7.0	0.20-0.60														●						
	160612 ET	2.5-7.0	0.25-0.60											●			●	●					
	190608 ET	3.0-9.0	0.20-0.60														●						
	190612 ET	3.0-9.0	0.25-0.60												●	●	●	●					
	190616 ET	3.0-9.0	0.30-0.65														●						





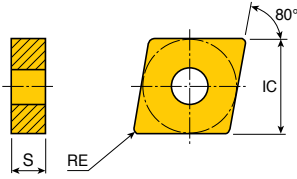

A58-A59, A100-A101, A146,
A170, A194, A203, A205

●: Standard items

Negative 80° rhombic inserts



Size	Dimension (mm)		
	IC	S	RE
12	12.7	4.76	0.4-1.2
16	15.88	6.35	0.8-1.2
19	19.05	6.35	0.8-1.6

Insert	Designation	ap (mm)	Feed (mm/rev)	Cermet		CVD coated										PVD coated											
				PV3010	CT3000	TT3005	TT7005	TT7015	TT7025	TT8105B	TT8115B	TT8125B	TT8135B	TT9215	TT9225	TT9235	TT15100	TT17100	TT15080	TT18020	TT9080	TT3010	TT3020	TT9020	K10		
 Medium	CNMG 120408 MGS	1.0-4.0	0.15-0.40			●																					
	120412 MGS	1.5-4.0	0.17-0.50			●																					
 Medium	CNMG 120404 ML	0.8-3.5	0.10-0.30																								
	120408 ML	1.0-3.5	0.12-0.35																								
	120412 ML	1.3-3.5	0.15-0.35																								
 Medium	CNMG 120408 MLP	0.5-3.5	0.10-0.40																								
	120412 MLP	0.6-3.5	0.15-0.50																								
 Type B Medium	CNMG 120404 MP	0.8-4.0	0.10-0.30																								
	120408 MP	1.0-4.0	0.12-0.40																								
	120412 MP	1.5-4.0	0.15-0.50																								
	160612 MP ✓	2.5-6.0	0.15-0.50																								
 Type B Medium	CNMG 120404 MT	1.0-5.0	0.15-0.40		●		●	●	●																		
	120408 MT	1.2-5.0	0.17-0.55	●	●		●	●	●	●	●	●	●	●	●	●	●	●	●	●	●	●	●	●	●	●	●
	120412 MT	1.5-5.0	0.20-0.55				●	●		●	●	●	●	●	●	●	●	●	●	●	●	●	●	●	●	●	●
	160608 MT ✓	2.0-6.5	0.20-0.55				●			●																	
	160612 MT ✓	2.0-6.5	0.25-0.55				●			●																	
	160616 MT	2.0-6.5	0.30-0.55							●																	
	190608 MT	3.0-8.0	0.23-0.55				●			●	●	●	●	●	●	●	●	●	●	●	●	●	●	●	●	●	●
	190612 MT	3.0-8.0	0.25-0.55							●	●	●	●	●	●	●	●	●	●	●	●	●	●	●	●	●	●
	190616 MT	3.0-8.0	0.30-0.55								●																



A58-A59, A100-A101, A146, A170, A194, A203, A205

▶ ✓: Type B chip breaker

●: Standard items

Negative 80° rhombic inserts

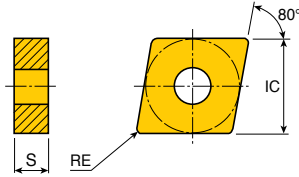

Size	Dimension (mm)		
	IC	S	RE
12	12.7	4.76	0.4-1.6
16	15.88	6.35	0.8-1.6
19	19.05	6.35	0.8-1.6
25	25.4	9.52	2.4

Insert	Designation	ap (mm)	Feed (mm/rev)	Coating																					
				Cermat		CVD coated										PVD coated									
				PV3010	CT3000	TT3005	TT7005	TT7015	TT7025	TT8105B	TT8115B	TT8125B	TT8135B	TT9215	TT9225	TT9235	TT5100	TT7100	TT5080	TT8020	TT9080	TT3010	TT3020	TT9020	K10
Medium	CNMG 120404 PC	0.4-5.0	0.10-0.40							●	●	●	●	●	●	●	●								
	120408 PC	0.5-5.0	0.15-0.50							●	●	●	●	●	●	●	●					●			
	120412 PC	0.6-5.0	0.17-0.55							●	●	●	●	●	●	●	●					●			
	120416 PC	0.8-5.0	0.20-0.60								●	●	●	●	●	●	●	●							
	160608 PC	2.0-6.5	0.20-0.55								●	●	●	●	●	●	●	●							
	160612 PC	2.0-6.5	0.25-0.55								●	●	●	●	●	●	●	●							
	160616 PC	2.0-6.5	0.30-0.55								●	●	●	●	●	●	●	●							
	190608 PC	3.0-8.0	0.23-0.55								●	●	●	●	●	●	●	●							
	190612 PC	3.0-8.0	0.25-0.55								●	●	●	●	●	●	●	●							
190616 PC	3.0-8.0	0.30-0.55								●	●	●	●	●	●	●	●								
Roughing	CNMG 120408 RGP	2.5-6.0	0.25-0.70									●	●												
	120412 RGP	2.5-6.0	0.25-0.70									●	●												
	120416 RGP	2.5-6.0	0.30-0.70									●	●												
	190616 RGP	3.0-9.0	0.30-0.85									●	●												
Type B Roughing	CNMG 120408 RT	2.5-6.0	0.25-0.70				●	●	●	●	●	●	●	●	●	●	●	●	●						
	120412 RT ✓	2.5-6.0	0.25-0.70				●	●	●	●	●	●	●	●	●	●	●	●	●						
	120416 RT	2.5-6.0	0.30-0.70				●	●	●	●	●	●	●	●	●	●	●	●	●						
	160612 RT	3.0-7.0	0.25-0.70				●	●	●	●	●	●	●	●	●	●	●	●	●						
	160616 RT	3.0-7.0	0.30-0.85				●	●	●	●	●	●	●	●	●	●	●	●	●						
	190608 RT	3.0-9.0	0.25-0.70							●	●	●	●	●	●	●	●	●	●						
	190612 RT	3.0-9.0	0.25-0.70				●	●	●	●	●	●	●	●	●	●	●	●	●						
	190616 RT	3.0-9.0	0.30-0.85				●	●	●	●	●	●	●	●	●	●	●	●	●						
	250924 RT	5.0-12.0	0.45-1.00								●	●	●	●	●	●	●	●	●						
Finishing	CNMG 120404 SF	0.5-1.5	0.08-0.25														●	●	●	●					
	120408 SF	0.7-1.5	0.10-0.30									●	●				●	●	●	●					



A58-A59, A100-A101, A146, A170, A194, A203, A205

▶ ✓: Type B chip breaker

●: Standard items

DNGG DNMA DNMG



Negative 55° rhombic inserts

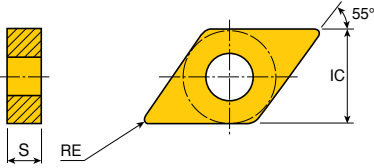

Size	Dimension (mm)		
	IC	S	RE
11	9.52	4.76	0.8
15	12.7	4.76-6.35	0.1-1.6

Insert	Designation	ap (mm)	Feed (mm/rev)	Coating																						
				Cermat		CVD coated							PVD coated													
				PV3010	CT3000	TT3005	TT7005	TT7015	TT7025	TT8105B	TT8115B	TT8125B	TT8135B	TT9215	TT9225	TT9235	TT5100	TT7100	TT5080	TT3010	TT3020	TT9020	TT4410	TT4430	K10	
Medium	DNGG 150401 ML	0.1-1.0	0.03-0.10																●						●	
	150402 ML	0.2-1.2	0.05-0.15																	●						●
	150404 ML	0.8-3.5	0.10-0.30																	●						●
	150408 ML	1.0-3.5	0.12-0.35																	●						●
Roughing	DNMA 150408	0.8-4.0	0.15-0.65				●	●																		
	150608	0.8-4.0	0.15-0.65				●	●																		
	150412	1.2-4.0	0.15-0.65				●	●																		
	150612	1.2-4.0	0.15-0.65					●																		
Medium	DNMG 150404	1.0-4.0	0.17-0.45					●				●														
	150604	1.0-4.0	0.17-0.45				●	●			●	●					●									
	150408	1.5-4.0	0.17-0.55								●															
	150608	1.5-4.0	0.17-0.55				●	●	●		●	●	●				●									●
	150412	1.5-4.0	0.25-0.55				●				●															
	150612	1.5-4.0	0.25-0.55				●		●		●	●					●									
	150416	2.5-4.0	0.25-0.65															●								
150616	2.5-4.0	0.25-0.65									●															
Finishing	DNMG 150404 EA	0.1-1.5	0.05-0.2												●											
	150408 EA	0.1-1.5	0.10-0.4											●												
	150604 EA	0.1-1.5	0.05-0.2												●				●	●	●	●				
	150608 EA	0.1-1.5	0.10-0.4											●					●	●	●	●				
Medium	DNMG 110408 EM #	0.5-4.0	0.13-0.50											●	●	●										
	150408 EM	0.5-5.0	0.13-0.50											●	●	●										
	150608 EM	0.5-5.0	0.13-0.50											●	●	●			●	●						
	150412 EM	0.5-5.0	0.15-0.55											●	●	●										
	150612 EM	0.5-5.0	0.15-0.55											●	●	●										
Roughing	DNMG 150408 ET	1.0-6.0	0.20-0.60											●	●	●			●						●	
	150412 ET	1.0-6.0	0.25-0.60											●	●	●			●						●	
	150608 ET	1.0-6.0	0.20-0.60											●	●				●		●	●	●			
	150612 ET	1.0-6.0	0.25-0.60											●	●				●		●	●	●			

A52, A53, A60-A61, A74,
A102, A146, A171, A177-A179,
A195, A203, A206, A215

▶ #: Insert with screw hole

●: Standard items



Negative 55° rhombic inserts

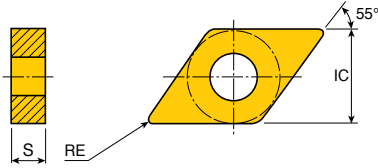

Size	Dimension (mm)		
	IC	S	RE
11	9.52	4.76	0.4-0.8
15	12.7	4.76-6.35	0.4-1.2

Insert	Designation	ap (mm)	Feed (mm/rev)	CVD coated												K10									
				Cermet	CVD coated								PVD coated												
				PV3010	CT3000	TT3005	TT7005	TT7015	TT7025	TT8105B	TT8115B	TT8125B	TT8135B	TT9215	TT9235	TT5100	TT7100	TT5080	TT8020	TT9080	TT3010	TT3020	TT9020		
Finishing	DNMG 150408 FA	0.2-2.0	0.05-0.20							●						●									
	150608 FA	0.2-2.0	0.05-0.20							●						●									
Finishing	DNMG 110404 FC #	0.5-2.0	0.07-0.20													●									
	110408 FC #	0.7-2.0	0.10-0.25							●	●			●		●									
	150404 FC	0.2-2.5	0.05-0.30							●	●	●													
	150604 FC	0.2-2.5	0.05-0.30								●				●										
	150408 FC	0.3-2.5	0.08-0.35							●	●	●					●								
	150608 FC	0.3-2.5	0.08-0.35							●	●	●					●								
	150412 FC	0.5-2.5	0.08-0.35							●	●	●					●								
	150612 FC	0.5-2.5	0.08-0.35									●													
Finishing	DNMG 110404 FG #	0.5-2.0	0.07-0.20	●	●					●	●			●		●									
	110408 FG #	0.7-2.0	0.10-0.25	●	●						●					●									
	150404 FG	0.5-2.0	0.07-0.20	●	●					●	●	●				●									
	150604 FG	0.5-2.0	0.07-0.20	●	●					●	●	●				●									
	150408 FG ✓	0.7-2.0	0.10-0.25	●	●					●	●	●				●									
	150412 FG ✓	1.0-2.0	0.12-0.25								●														
	150608 FG ✓	0.7-2.0	0.10-0.25	●	●					●	●	●				●									
Finishing	DNMG 150604 FLP	0.2-2.0	0.08-0.30							●	●														
	150608 FLP	0.3-2.0	0.10-0.30							●	●														
Roughing	DNMG 150408 KT	0.38-7.0	0.17-0.47				●	●	●																
	150608 KT	0.38-7.0	0.17-0.47				●	●	●																
	150412 KT	0.5-7.0	0.23-0.63				●	●	●																
	150612 KT	0.5-7.0	0.23-0.63				●	●	●																

A52, A53, A60-A61, A74, A102, A146, A171, A177-A179, A195, A203, A206, A215

▶ #: Insert with screw hole
▶ ✓: Type B chip breaker

●: Standard items

Negative 55° rhombic inserts

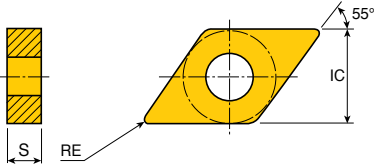

Size	Dimension (mm)		
	IC	S	RE
15	12.7	4.76-6.35	0.4-1.2

Insert	Designation	ap (mm)	Feed (mm/rev)	Coating																							
				Cermet		CVD coated							PVD coated														
				PV3010	CT3000	TT3005	TT7005	TT7015	TT7025	TT8105B	TT8115B	TT8125B	TT8135B	TT9215	TT9225	TT9235	TT15100	TT7100	TT15080	TT8020	TT9080	TT3010	TT3020	TT9020	K10		
Medium	DNMG 150604 MC	0.5-3.5	0.10-0.30							●	●						●										
	150408 MC	0.7-3.5	0.12-0.35							●	●	●															
	150608 MC	0.7-3.5	0.12-0.35								●	●	●				●	●		●							
	150412 MC	1.0-3.5	0.15-0.35								●							●									
	150612 MC	1.0-3.5	0.15-0.35									●						●									
Medium	DNMG 150608 MGP	0.5-4.0	0.15-0.50								●	●															
	150612 MGP	0.6-4.0	0.17-0.55								●	●															
Medium	DNMG 150408 MGS	1.0-4.0	0.15-0.40			●																●	●		●		
	150608 MGS	1.0-4.0	0.15-0.40			●																●	●		●		
	150612 MGS	1.0-4.0	0.17-0.40			●																●	●		●		
Medium	DNMG 150404 ML	0.8-3.5	0.10-0.30									●					●		●						●		
	150604 ML	0.8-3.5	0.10-0.30									●	●				●		●						●		
	150408 ML	1.0-3.5	0.12-0.35									●					●		●						●		
	150608 ML	1.0-3.5	0.12-0.35									●	●		●		●	●	●						●		
Medium	DNMG 150608 MLP	0.3-3.5	0.10-0.40								●	●															
	150612 MLP	0.35-3.5	0.15-0.50								●	●															
Medium Type B	DNMG 150404 MP	0.8-4.0	0.10-0.30								●					●		●									
	150604 MP	0.8-4.0	0.10-0.30								●	●				●		●		●							
	150408 MP	1.0-4.0	0.12-0.40								●						●		●		●						
	150608 MP	1.0-4.0	0.12-0.40								●	●				●	●	●		●	●	●					
	150612 MP	1.0-4.0	0.15-0.40								●				●	●	●	●		●							



A52, A53, A60-A61, A74,
A102, A146, A171, A177-A179,
A195, A203, A206, A215

▶ √: Type B chip breaker

●: Standard items

Negative 55° rhombic inserts

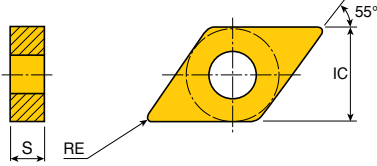

Size	Dimension (mm)		
	IC	S	RE
11	9.52	4.76	0.8-1.2
15	12.7	4.76-6.35	0.4-1.6

Insert	Designation	ap (mm)	Feed (mm/rev)	Cermat		CVD coated								PVD coated											
				PV3010	CT3000	TT3005	TT7005	TT7015	TT7025	TT8105B	TT8115B	TT8125B	TT8135B	TT9215	TT9225	TT9235	TT5100	TT7100	TT5080	TT8020	TT9080	TT3010	TT3020	TT9020	K10
Medium	DNMG 110408 MT #	1.0-3.0	0.17-0.40	●		●	●								●		●								
	110412 MT #	1.0-3.0	0.20-0.45			●	●																		
	150404 MT	0.8-4.0	0.15-0.40	●			●	●							●										
	150604 MT	0.8-4.0	0.15-0.40	●		●	●	●							●		●								
	150408 MT	1.0-4.0	0.17-0.50	●		●	●	●							●			●	●						
	150608 MT	1.0-4.0	0.17-0.50	●		●	●	●			●	●	●	●	●		●	●							
	150412 MT	1.3-4.0	0.20-0.50				●								●										
	150612 MT	1.3-4.0	0.20-0.50			●	●	●							●		●	●							
Medium	DNMG 110408 PC #	0.5-3.0	0.17-0.40								●	●	●												
	150404 PC	0.4-4.0	0.10-0.40								●	●	●												
	150604 PC	0.4-4.0	0.10-0.40								●	●	●	●	●										
	150408 PC	0.5-4.0	0.15-0.50								●	●	●				●								
	150608 PC	0.5-4.0	0.15-0.50								●	●	●	●	●	●									
	150412 PC	0.6-4.0	0.17-0.55								●	●	●			●									
	150612 PC	0.6-4.0	0.17-0.55								●	●	●												
Roughing	DNMG 150408 RT	2.0-4.0	0.25-0.65				●	●	●	●															
	150608 RT	2.0-4.0	0.25-0.65				●	●	●	●					●										
	150412 RT	2.5-4.0	0.25-0.65					●			●														
	150612 RT	2.5-4.0	0.25-0.65				●	●	●																
	150616 RT	2.5-5.5	0.25-0.70								●	●			●										
Right hand Medium	DNMG 150404 L-VF	0.7-4.5	0.10-0.35									●													
	150404 R-VF	0.7-4.5	0.10-0.35	●								●			●										
	150604 L-VF	0.7-4.5	0.10-0.35									●			●										
	150604 R-VF	0.7-4.5	0.10-0.35	●								●			●										
	150408 L-VF	1.0-4.5	0.12-0.45									●					●	●							
	150408 R-VF	1.0-4.5	0.12-0.45									●					●	●							
	150608 L-VF	1.0-4.5	0.12-0.45									●				●	●								
	150608 R-VF	1.0-4.5	0.12-0.45	●								●				●	●								

A52, A53, A60-A61, A74, A102, A146, A171, A177-A179, A195, A203, A206, A215

▶ #: Insert with screw hole

●: Standard items

Negative 120° hexagonal inserts

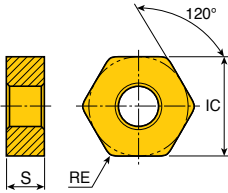

Size	Dimension (mm)		
	IC	S	RE
05	12.7	4.76	0.8
10	19.05	6.35	1.2

Insert	Designation	ap (mm)	Feed (mm/rev)	Cermet		CVD coated								PVD coated											
				PV3010	CT3000	TT3005	TT7005	TT7015	TT7025	TT8105B	TT8115B	TT8125B	TT8135B	TT9215	TT9225	TT9235	TT5100	TT7100	TT5080	TT8020	TT9080	TT3010	TT3020	TT9020	K10
Medium	HNMG 050408 GU	0.5-3.5	0.15-0.60					●	●																
	100612 GU	1.0-5.0	0.25-0.70					●	●			●													
Medium	HNMG 050408 SU	0.5-3.5	0.15-0.50																						
	100612 SU	1.0-5.0	0.25-0.70																						

A103, A196

● : Standard items



KNUX

Negative 55° rhombic inserts

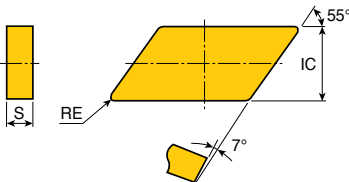

Size	Dimension (mm)		
	IC	S	RE
16	9.52	4.76	0.5-1.0

Insert	Designation	ap (mm)	Feed (mm/rev)	Cermet		CVD coated								PVD coated												
				PV3010	CT3000	TT3005	TT7005	TT7015	TT7025	TT8105B	TT8115B	TT8125B	TT8135B	TT9215	TT9225	TT9235	TT5100	TT7100	TT5080	TT8020	TT9080	TT3010	TT3020	TT9020	K10	
Right hand Medium	KNUX 160405 L11	1.5-5.0	0.15-0.35																							
	160405 R11	1.5-5.0	0.15-0.35					●																		
	160410 L11	2.0-5.0	0.21-0.45																							
	160410 R11	2.0-5.0	0.21-0.45																							
Right hand Medium	KNUX 160405 L12	2.0-5.0	0.24-0.50																							
	160405 R12	2.0-5.0	0.24-0.50																							
	160410 L12	2.5-6.0	0.30-0.60																							
	160410 R12	2.5-6.0	0.30-0.60																							

A47, A165

● : Standard items



Negative square inserts

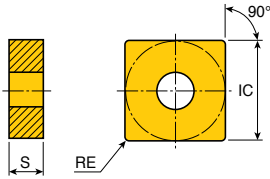

Size	Dimension (mm)		
	IC	S	RE
12	12.7	4.76	0.4-1.6
15	15.88	6.35	0.8-1.6
19	19.05	6.35	0.4-1.6
25	25.4	7.94-9.52	1.6-2.4

Insert	Designation	ap (mm)	Feed (mm/rev)	Cermat		CVD coated								PVD coated											
				PV3010	CT3000	TT3005	TT7005	TT7015	TT7025	TT8105B	TT8115B	TT8125B	TT8135B	TT9215	TT9235	TT5100	TT7100	TT5080	TT8020	TT9080	TT3010	TT3020	TT9020	K10	
Medium	SNMG 120404	1.0-5.0	0.17-0.45							●	●			●											
	120408	1.5-5.0	0.23-0.60					●	●	●		●	●	●											
	120412	2.0-5.0	0.25-0.60							●				●											
	120416	2.0-5.0	0.35-0.70											●											
	150608	1.5-6.0	0.25-0.60											●											
	150612	2.0-6.0	0.25-0.60											●											
	150616	2.0-6.0	0.35-0.70											●											
	190604	3.0-8.0	0.17-0.45												●										
	190608	3.0-8.0	0.25-0.60						●						●			●							
	190612	3.0-8.0	0.30-0.60						●	●					●										
	190616	3.0-8.0	0.35-0.70												●										
	250716	4.0-12.0	0.35-0.70												●										
	250724	5.0-12.0	0.50-1.00												●										
250924	5.0-12.0	0.50-1.00												●											
Finishing	SNMG 120404 EA	0.1-1.5	0.05-0.20											●	●										
	120408 EA	0.1-1.5	0.10-0.40											●	●										
Medium	SNMG 120408 EM	0.8-5.0	0.13-0.50											●	●	●		●	●						
	120412 EM	0.8-5.0	0.15-0.55											●	●	●		●							
	150612 EM	0.8-6.5	0.15-0.55											●	●	●		●	●						
	150616 EM	0.8-6.5	0.17-0.60											●	●	●		●	●						
	190612 EM	0.8-8.0	0.15-0.55											●	●	●		●							
	190616 EM	0.8-8.0	0.17-0.60											●	●	●		●							
Roughing	SNMG 120408 ET	2.0-7.0	0.25-0.70											●	●	●		●			●	●			
	120412 ET	2.0-7.0	0.30-0.70											●	●	●		●			●	●			
	190608 ET	3.0-9.0	0.30-0.75											●	●	●		●	●						
	190612 ET	3.0-9.0	0.35-0.75											●	●	●		●							

A65, A66, A104,
 A105, A147, A172,
 A197

●: Standard items

Negative square inserts

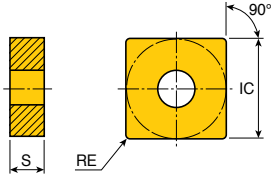

Size	Dimension (mm)		
	IC	S	RE
12	12.7	4.76	0.4-1.6
15	15.88	6.35	1.2-1.6
19	19.05	6.35	1.6

Insert	Designation	ap (mm)	Feed (mm/rev)	Cermat		CVD coated										PVD coated											
				PV3010	CT3000	TT3005	TT7005	TT7015	TT7025	TT8105B	TT8115B	TT8125B	TT8135B	TT9215	TT9225	TT9235	TT15100	TT7100	TT5080	TT8020	TT9080	TT3010	TT3020	TT9020	K10		
	SNMG 120404 FC	0.2-2.5	0.05-0.30																								
	120408 FC	0.2-2.5	0.08-0.35																								
	120412 FC	0.3-2.5	0.10-0.40																								
Finishing																											
	SNMG 120404 FG	0.5-3.0	0.07-0.20		•																						
	120408 FG	0.7-3.0	0.10-0.25	•	•																						
Finishing																											
	SNMG 120408 KT	0.38-7.0	0.19-0.53							•	•	•															
	120412 KT	0.50-7.0	0.28-0.70							•	•	•															
	120416 KT	0.75-7.0	0.30-0.75							•	•																
	150612 KT	0.6-8.5	0.30-0.75							•	•																
	150616 KT	0.9-8.5	0.30-0.85							•	•																
	190616 KT	1.3-12.0	0.30-0.85							•	•																
Roughing																											
	SNMG 120408 MC	0.7-3.5	0.12-0.35																								
	120412 MC	0.7-3.5	0.15-0.40																								
Medium																											
	SNMG 120408 MGP	0.5-5.0	0.15-0.50																								
Medium																											
	SNMG 120408 MGS	1.0-4.0	0.15-0.40																								
	120412 MGS	1.3-4.0	0.17-0.40																								
	190616 MGS	1.5-8.0	0.17-0.60																								
Medium																											
	SNMG 120408 ML	1.0-3.5	0.12-0.35																								
	120412 ML	1.0-3.5	0.15-0.35																								
Medium																											

• Standard items



A65, A66, A104,
A105, A147, A172,
A197

Negative square inserts

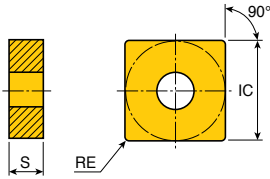

Size	Dimension (mm)		
	IC	S	RE
12	12.7	4.76	0.4-1.2
15	15.88	6.35	0.8
19	19.05	6.35	1.2-2.4
25	25.4	7.94-9.52	2.4-3.2

Insert	Designation	ap (mm)	Feed (mm/rev)	Coating																					
				Cermet		CVD coated							PVD coated												
				PV3010	CT3000	TT3005	TT7005	TT7015	TT7025	TT8105B	TT8115B	TT8125B	TT8135B	TT9215	TT9225	TT9235	TT15100	TT7100	TT5080	TT8020	TT9080	TT3010	TT3020	TT9020	K10
 Type B Medium	SNMG 120404 MP ✓	0.8-4.0	0.10-0.30								●	●					●			●					
	120408 MP	1.0-4.0	0.12-0.40								●	●		●			●		●	●	●				
	120412 MP	1.3-4.0	0.15-0.40									●					●								
	150608 MP	1.5-6.0	0.25-0.60									●													
 Type B Medium	SNMG 120404 MT ✓	1.0-5.0	0.12-0.40		●							●					●								
	120408 MT	1.2-5.0	0.17-0.55		●		●	●	●		●	●	●	●	●	●	●	●		●	●				
	120412 MT	1.5-5.0	0.20-0.55				●				●	●			●		●			●	●				
	150612 MT ✓	2.0-7.0	0.30-0.65									●	●												
	190608 MT	3.0-8.0	0.17-0.55									●			●										
190612 MT	3.0-8.0	0.20-0.55									●			●	●	●					●				
 Medium	SNMG 120404 PC	0.4-5.0	0.12-0.40									●													
	120408 PC	0.5-5.0	0.15-0.50								●	●			●		●					●			
	120412 PC	0.6-5.0	0.15-0.50								●	●													
 Type B Roughing	SNMG 120408 RT	2.5-6.0	0.25-0.70				●	●			●	●					●								
	120412 RT	2.5-6.0	0.30-0.70				●	●		●	●	●			●										
	120416 RT	2.5-6.0	0.40-0.70							●	●	●													
	150612 RT	3.0-7.0	0.30-0.70				●			●												●			
	190612 RT	3.0-9.0	0.30-0.75								●	●	●	●	●	●	●	●			●				
	190616 RT ✓	3.0-9.0	0.40-0.90								●	●	●	●	●	●	●	●			●	●			
	250924 RT	5.0-12.0	0.40-1.00											●											
 Roughing	SNMM 250924 EH	2.8-18.0	0.45-1.20											●	●	●									
 Roughing	SNMM 190612 HT	4.0-9.0	0.35-0.90								●	●													
	190616 HT	4.0-9.0	0.45-1.00								●	●						●							
	190624 HT	4.0-9.0	0.55-1.20								●														
	250724 HT	5.0-12.0	0.55-1.30								●	●		●		●	●								
	250924 HT	5.0-12.0	0.55-1.30								●										●				
250932 HT	5.0-13.0	0.65-1.30										●													

A65, A66, A104,
 A105, A147, A172,
 A197

▶ ✓: Type B chip breaker

●: Standard items

TNGG TNMA TNMG



Negative triangular inserts

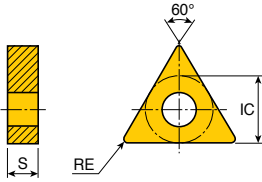

Size	Dimension (mm)		
	IC	S	RE
11	6.35	3.18	0.4-0.8
16	9.52	4.76	0.4-1.6
22	12.7	4.76	0.4-1.6
27	15.88	6.35	0.8-1.6
33	19.05	7.94-9.52	1.6-2.4

Insert	Designation	ap (mm)	Feed (mm/rev)	Cermet		CVD coated										PVD coated									
				PV3010	CT3000	TT3005	TT7005	TT7015	TT7025	TT8105B	TT8115B	TT8125B	TT8135B	TT9215	TT9225	TT9235	TT5100	TT7100	TT5080	TT8020	TT9080	TT3010	TT3020	TT9020	K10
 Left hand Medium	TNGG 160404 L	1.0-3.5	0.12-0.30	●																					
	160404 R	1.0-3.5	0.12-0.30	●																					
	160408 L	1.3-3.5	0.15-0.35	●																					
	160408 R	1.3-3.5	0.15-0.35	●																					
	220404 L	1.0-5.0	0.12-0.30	●																					
	220404 R	1.0-5.0	0.12-0.30	●																					
	220408 L	1.3-5.0	0.15-0.35	●																					
	220408 R	1.3-5.0	0.15-0.35	●																					
 Roughing	TNMA 160404	1.0-4.0	0.15-0.30				●	●	●																
	160408	1.0-4.0	0.15-0.40				●	●	●																
	160412	1.5-4.5	0.20-0.50					●	●																
	160416	1.0-4.5	0.20-0.50				●																		
	220408	1.5-5.0	0.15-0.40					●	●																
	220412	1.5-5.0	0.20-0.50					●	●																
	220416	2.0-5.0	0.20-0.61					●	●																
 Medium	TNMG 110304	1.2-3.0	0.15-0.40									●	●												
	110308	1.5-3.0	0.17-0.40									●													
	160404	1.5-3.5	0.17-0.45				●	●	●	●				●					●						●
	160408	2.0-3.5	0.17-0.55				●	●	●	●				●					●						●
	160412	2.0-3.5	0.25-0.55									●													
	220404	1.5-5.0	0.17-0.45				●					●	●						●						
	220408	2.0-5.0	0.17-0.55				●	●				●	●						●	●					
	220412	2.0-5.0	0.25-0.55									●													
	220416	2.0-5.0	0.30-0.60									●													
	270608	2.0-5.0	0.17-0.55									●	●												
	270612	3.0-7.0	0.25-0.55									●													
	270616	3.0-7.0	0.30-0.60									●													
	330716	3.0-9.0	0.35-0.70									●	●							●					
	330924	3.0-9.0	0.40-0.80									●													

A54, A67, A68, A106,
 A114, A115, A148,
 A173, A200, A204

●: Standard items

Negative triangular inserts

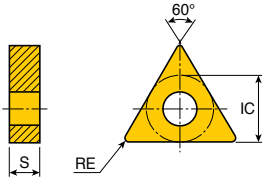

Size	Dimension (mm)		
	IC	S	RE
11	6.35	3.18	0.4
16	9.52	4.76	0.4-1.2
22	12.7	4.76	0.8-1.2

Insert	Designation	ap (mm)	Feed (mm/rev)	Coating																			
				Cermat			CVD coated						PVD coated				K10						
				PV3010	CT3000	TT7005	TT7015	TT7025	TT8105B	TT8115B	TT8125B	TT8135B	TT9215	TT9235	TT5100	TT7100		TT5080	TT8020	TT9080	TT3010	TT3020	TT9020
Finishing	TNMG 160404 EA	0.1-1.5	0.05-0.20										●	●			●	●					
	160408 EA	0.1-1.5	0.10-0.40														●	●					
Medium	TNMG 160408 EM	0.8-4.5	0.13-0.50										●	●			●	●					
	160412 EM	0.8-4.5	0.15-0.55														●	●					
	220408 EM	0.8-6.0	0.13-0.50										●	●	●			●					
	220412 EM	0.8-6.0	0.15-0.55										●					●					
Roughing	TNMG 160408 ET	2.0-5.0	0.25-0.65										●	●	●		●	●					
	220408 ET	2.5-7.0	0.25-0.65										●	●	●		●	●					
	220412 ET	2.5-7.0	0.25-0.65										●		●		●	●					
Finishing	TNMG 160404 FC	0.2-2.5	0.05-0.30						●	●	●			●			●						
	160408 FC	0.2-2.5	0.08-0.35						●	●	●			●	●	●							
	160412 FC	0.3-2.5	0.10-0.40						●	●													
Finishing	TNMG 110304 FG	0.5-1.5	0.07-0.20	●											●								
	160404 FG	0.5-2.0	0.07-0.20	●	●				●	●					●								
	160408 FG	0.7-2.0	0.10-0.25	●	●				●	●					●								
	160412 FG	0.7-2.0	0.13-0.30	●																			
	220408 FG	0.7-2.0	0.10-0.25							●	●												
Finishing	TNMG 160404 FLP	0.2-2.0	0.08-0.30						●	●													
	160408 FLP	0.3-2.0	0.10-0.30						●	●													
Right hand Medium	TNMG 160404 L-FS	0.8-3.0	0.15-0.30	●					●						●								
	160404 R-FS	0.8-3.0	0.15-0.30	●					●						●			●					
	160408 L-FS	1.0-3.5	0.20-0.40						●														
	160408 R-FS	1.0-3.5	0.20-0.40						●						●			●					



A54, A67, A68, A106,
A114, A115, A148,
A173, A200, A204

● Standard items

Negative triangular inserts

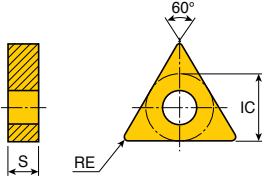

Size	Dimension (mm)		
	IC	S	RE
11	6.35	3.18	0.8
16	9.52	4.76	0.4-1.2
22	12.7	4.76	0.4-1.2
27	15.88	6.35	1.2

Insert	Designation	ap (mm)	Feed (mm/rev)	Coating																					
				Cermet			CVD coated							PVD coated			K10								
				PV3010	CT3000	TT3005	TT7005	TT7015	TT7025	TT8105B	TT8115B	TT8125B	TT8135B	TT9215	TT9225	TT9235		TT5100	TT7100	TT5080	TT8020	TT9080	TT3010	TT3020	TT9020
 Roughing	TNMG 160408 KT	0.34-6.2	0.17-0.42				●	●	●																
	160412 KT	0.45-6.3	0.20-0.56				●	●																	
	220408 KT	0.38-7.0	0.19-0.53				●	●																	
	220412 KT	0.5-7.0	0.25-0.70				●	●																	
 Medium	TNMG 160408 MC	0.7-3.5	0.17-0.40								●	●					●								
 Medium	TNMG 160408 MGP	0.5-4.5	0.15-0.50								●	●													
	160412 MGP	0.6-4.5	0.17-0.55								●	●													
 Medium	TNMG 160404 ML	0.8-3.5	0.10-0.30								●	●					●		●	●					
	160408 ML	1.0-3.5	0.12-0.35								●	●	●				●		●	●					
	160412 ML	1.5-3.5	0.15-0.35																						
	220404 ML	1.0-4.0	0.10-0.30															●							●
	220408 ML	1.0-4.0	0.12-0.35									●						●							●
 Medium	TNMG 160404 MLP	0.25-2.5	0.07-0.30								●	●													
	160408 MLP	0.30-2.5	0.10-0.40								●	●													
	160412 MLP	0.35-2.5	0.15-0.50								●	●													
 Medium	TNMG 160404 MP	0.8-3.5	0.10-0.30								●			●		●		●	●	●	●	●			
	160408 MP	1.0-3.5	0.12-0.40								●	●		●	●	●		●	●	●	●	●			
	160412 MP	1.5-3.5	0.15-0.40								●						●		●		●	●			
	220404 MP	1.0-3.5	0.12-0.35															●							
	220408 MP	1.0-4.0	0.12-0.40								●	●		●				●	●						
 Medium	TNMG 110308 MT	1.0-3.0	0.17-0.40								●	●					●								
	160404 MT	1.0-3.5	0.17-0.40		●		●	●			●	●					●		●	●					
	160408 MT	1.2-3.5	0.17-0.50		●		●	●	●		●	●		●			●		●	●					
	160412 MT	1.5-3.5	0.20-0.50				●				●	●					●								
	220404 MT	1.2-5.0	0.15-0.40								●	●													
	220408 MT	1.2-5.0	0.17-0.50				●				●	●								●					
	220412 MT ✓	1.5-5.0	0.20-0.50								●	●							●		●				
270612 MT ✓	3.0-7.0	0.20-0.50					●					●						●		●					

A54, A67, A68, A106, A114, A115, A148, A173, A200, A204

▶ ✓: Type B chip breaker

●: Standard items



TNMG TNMM



Negative triangular inserts

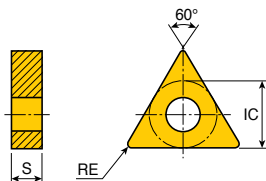

Size	Dimension (mm)		
	IC	S	RE
16	9.52	4.76	0.4-1.2
22	12.7	4.76	0.8-1.6
27	15.88	6.35	1.2
33	19.05	9.52	2.4

Insert	Designation	ap (mm)	Feed (mm/rev)	Coating																						
				Cermat			CVD coated							PVD coated												
				PV3010	CT3000	TT3005	TT7005	TT7015	TT7025	TT8105B	TT8115B	TT8125B	TT8135B	TT9215	TT9225	TT9235	TT15100	TT7100	TT5080	TT8020	TT9080	TT3010	TT3020	TT9020	K10	
 Medium	TNMG 160404 PC	1.0-3.5	0.15-0.40							●	●	●		●												
	160408 PC	0.5-4.5	0.15-0.50							●	●	●		●	●	●						●				
	160412 PC	0.6-4.5	0.17-0.55							●	●	●														
	220408 PC	1.2-5.0	0.17-0.50								●	●														
	220412 PC	1.5-5.0	0.20-0.50								●	●														
 Roughing	TNMG 160408 RT	2.0-5.0	0.25-0.65				●	●	●		●															
	160412 RT	2.0-5.0	0.25-0.65				●	●	●		●															
	220408 RT	2.0-7.0	0.25-0.65								●	●					●									
	220412 RT	2.5-7.0	0.25-0.65						●																	
	330924 RT	3.0-9.0	0.35-0.70									●	●					●								
 Finishing	TNMG 160408 SF	0.7-1.5	0.10-0.30														●		●							
 Right hand Medium	TNMG 160404 L-VF	0.7-3.5	0.10-0.30		●						●	●					●									
	160404 R-VF	0.7-3.5	0.10-0.30	●	●						●	●					●				●					
	160408 L-VF	1.0-3.5	0.12-0.35								●	●					●									
	160408 R-VF	1.0-3.5	0.12-0.35								●	●					●									
 Type B Roughing	TNMM160408 RH	2.0-7.0	0.30-0.70									●														
	220408 RH	2.0-7.0	0.30-0.70							●	●	●														
	220412 RH	2.5-7.0	0.30-0.70								●	●					●	●								
	270612 RH ✓	3.0-8.0	0.30-0.80								●															
 Roughing	TNMM160408 RX	0.7-6.0	0.20-0.55								●	●	●													
	160412 RX	1.0-7.0	0.25-0.70								●	●	●													
	220408 RX	0.7-7.5	0.20-0.55								●	●	●													
	220412 RX	1.0-7.5	0.25-0.70								●	●	●													
	220416 RX	1.5-7.5	0.30-0.90								●	●	●													

A54, A67, A68, A106,
A114, A115, A148,
A173, A200, A204

▶ ✓: Type B chip breaker

●: Standard items

VNGG VNMG



Negative 35° rhombic inserts

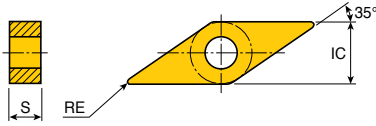

Size	Dimension (mm)		
	IC	S	RE
13	7.94	4.76	0.4-0.8
16	9.52	4.76	0.1-1.2

Insert	Designation	ap (mm)	Feed (mm/rev)	Coating																					
				Cermet		CVD coated							PVD coated					K10							
				PV3010	CT3000	TT3005	TT7005	TT7015	TT8115B	TT8125B	TT8135B	TT9215	TT9225	TT9235	TT5100	TT7100	TT5080		TT8020	TT9080	TT3010	TT3020	TT9020	TT4410	TT4430
Medium	VNGG 160401 ML	0.1-1.0	0.03-0.10																						●
	160402 ML	0.2-1.2	0.05-0.15														●								●
	160404 ML	0.8-3.0	0.10-0.27														●								●
	160408 ML	0.8-3.5	0.10-0.30														●								●
Medium	VNMG 160404	1.0-3.0	0.17-0.40				●	●	●						●										
	160408	1.5-3.0	0.17-0.50				●	●	●						●										
	160412	1.5-3.0	0.20-0.50				●	●	●																
Finishing	VNMG 160404 EA	0.1-1.5	0.05-0.20										●	●			●	●	●	●					
	160408 EA	0.2-2.5	0.08-0.30						●				●				●		●	●					
Medium	VNMG 160408 EM	0.8-3.5	0.13-0.50										●					●							
	VNMG 160408 FA	0.3-2.0	0.05-0.25						●						●		●								
Finishing	VNMG 130404 FC #	0.5-1.5	0.08-0.20						●	●			●												
	130408 FC #	0.5-2.0	0.10-0.23							●															
	160404 FC	0.3-2.5	0.05-0.30						●	●			●												
	160408 FC	0.3-2.5	0.08-0.35						●	●			●												
Finishing	VNMG 130404 FG #	0.5-1.5	0.08-0.20		●					●	●						●	●							
	130408 FG #	0.5-2.0	0.10-0.23		●					●	●														
	160404 FG	0.5-2.0	0.08-0.20	●	●				●	●	●		●				●	●	●						
	160408 FG	0.5-2.0	0.10-0.23	●	●				●	●	●		●				●	●							
Finishing	VNMG 160404 FLP	0.2-1.5	0.08-0.30							●	●														
	160408 FLP	0.3-1.5	0.10-0.30							●	●														
	160412 FLP	0.4-1.5	0.12-0.30							●	●														

A55, A56, A87, A108, A148, A188, A190, A206

▶ #: Insert with screw hole

●: Standard items

Negative 35° rhombic inserts

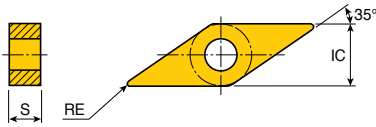

Size	Dimension (mm)		
	IC	S	RE
13	7.94	4.76	0.4-0.8
16	9.52	4.76	0.4-1.2

Insert	Designation	ap (mm)	Feed (mm/rev)	Coating																						
				Cermet		CVD coated										PVD coated										
				PV3010	CT3000	TT3005	TT7005	TT7015	TT7025	TT8105B	TT8115B	TT8125B	TT8135B	TT9215	TT9225	TT9235	TT15100	TT17100	TT15080	TT18020	TT19080	TT13010	TT13020	TT19020	K10	
Finishing	VNMG 160404 FX	0.2-2.0	0.05-0.20	●							●	●														
	160408 FX	0.2-2.0	0.07-0.20	●							●	●	●													
	160412 FX	0.2-2.0	0.10-0.23									●	●													
Medium	VNMG 160408 MGP	0.5-3.0	0.17-0.36								●	●														
Medium	VNMG 130404 MT #	0.8-2.5	0.15-0.36	●			●	●		●							●									
	130408 MT #	1.0-2.5	0.17-0.36	●		●				●	●						●									
	160404 MT ✓	0.8-3.0	0.15-0.36	●					●	●	●				●		●		●							
	160408 MT	1.0-2.5	0.17-0.36	●		●	●	●	●	●	●				●	●	●		●	●						
Medium	VNMG 160404 PC	0.4-3.0	0.15-0.36							●	●	●		●												
	160408 PC	0.5-3.0	0.17-0.36							●	●	●														
Medium	VNMM160404 ML	0.8-3.0	0.10-0.27																						●	
	160408 ML	1.0-3.0	0.12-0.32														●								●	

A55, A56, A87, A108, A148, A188, A190

▶ ✓: Type B chip breaker
 ▶ #: Insert with screw hole

●: Standard items

Negative 80° trigon inserts

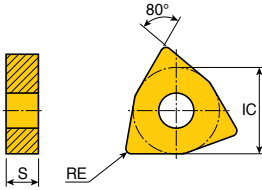

Size	Dimension (mm)		
	IC	S	RE
06	9.52	4.76	0.4-1.2
08	12.7	4.76	0.4-1.6

Insert	Designation	ap (mm)	Feed (mm/rev)	Coating																					
				Cermat		CVD coated							PVD coated												
				PV3010	CT3000	TT3005	TT7005	TT7015	TT7025	TT8105B	TT8115B	TT8125B	TT8135B	TT9215	TT9225	TT9235	TT5100	TT7100	TT5080	TT8020	TT9080	TT3010	TT3020	TT9020	K10
 Roughing	WNMA 060408	1.0-4.0	0.15-0.70					●																	
	060412	1.5-4.0	0.20-0.80				●																		
	080408	1.0-5.0	0.15-0.70				●	●																	
	080412	1.5-5.0	0.20-0.80				●	●																	
	080416	1.5-5.0	0.20-0.80				●	●																	
 Finishing	WNMG 080404 EA	0.1-1.5	0.05-0.20																●	●					
	080408 EA	0.1-1.5	0.10-0.40											●	●	●			●						
 Medium	WNMG 060408 EM	0.8-3.0	0.13-0.50												●				●	●					
	060412 EM	0.8-3.0	0.15-0.55											●	●	●			●	●					
	080404 EM	0.8-4.0	0.10-0.45											●	●	●				●					
	080408 EM	0.8-4.0	0.12-0.45											●	●	●			●	●					
	080412 EM	0.8-4.0	0.12-0.45											●	●	●			●	●					
 Roughing	WNMG 060408 ET	0.8-4.0	0.15-0.50											●	●	●			●	●					
	060412 ET	0.8-4.0	0.15-0.50											●	●	●			●	●					
	080408 ET	0.8-4.5	0.15-0.55											●	●				●						
	080412 ET	0.8-4.5	0.20-0.50											●	●				●						
 Finishing	WNMG 060404 FC	0.5-2.0	0.07-0.20								●	●			●										
	080404 FC	0.5-2.0	0.07-0.20								●	●			●										
	080408 FC	0.5-2.0	0.07-0.20								●	●	●		●	●	●								
	080412 FC	0.5-2.0	0.10-0.25									●													
 Finishing	WNMG 060404 FG	0.5-2.0	0.07-0.20	●	●						●	●						●							
	060408 FG	0.7-2.0	0.10-0.25	●	●						●														
	080404 FG	0.5-2.0	0.07-0.20	●	●						●	●	●		●	●			●	●					
	080408 FG	0.7-2.0	0.10-0.25	●	●						●	●						●							

A57, A69, A109,
 A149, A169,
 A198, A207

●: Standard items

Negative 80° trigon inserts

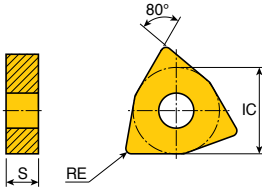

Size	Dimension (mm)		
	IC	S	RE
06	9.52	4.76	0.4-1.2
08	12.7	4.76	0.4-1.6

Insert	Designation	ap (mm)	Feed (mm/rev)	Coating																					
				Cermet		CVD coated								PVD coated				K10							
				PV3010	CT3000	TT3005	TT7005	TT7015	TT7025	TT8105B	TT8115B	TT8125B	TT8135B	TT9215	TT9225	TT9235	TT5100		TT7100	TT5080	TT8020	TT9080	TT3010	TT3020	TT9020
 Type B Medium	WNMG 060404 MT	1.0-3.0	0.12-0.40				●	●		●	●			●	●		●		●	●					
	060408 MT	1.2-3.0	0.15-0.45				●	●		●	●			●	●		●		●	●					
	060412 MT	1.5-3.0	0.23-0.50								●														
	080404 MT ✓	1.0-4.0	0.12-0.40		●			●	●		●	●			●	●		●		●	●				
	080408 MT	1.2-4.0	0.17-0.55		●			●	●		●	●			●	●		●		●	●				
	080412 MT	1.5-4.0	0.25-0.55								●	●			●	●		●		●	●				
	080416 MT	1.5-4.0	0.25-0.55								●	●									●				
 Medium	WNMG 060408 PC	0.5-4.0	0.15-0.50								●	●													
	060412 PC	0.6-4.0	0.17-0.50								●	●													
	080408 PC	0.5-4.0	0.15-0.50								●	●			●	●			●	●					
	080412 PC	0.6-4.0	0.17-0.50								●	●	●		●						●	●			
	080416 PC	0.8-4.0	0.20-0.50									●	●												
 Roughing	WNMG 080408 RGP	2.5-4.0	0.25-0.70								●	●													
	080412 RGP	2.5-4.0	0.25-0.70								●	●													
	080416 RGP	2.5-4.0	0.30-0.75									●	●												
 Roughing	WNMG 080408 RT	2.5-4.0	0.25-0.70				●	●		●	●	●		●	●	●		●		●	●				
	080412 RT	2.5-4.0	0.25-0.70				●	●	●		●	●						●	●						
	080416 RT	2.5-4.0	0.30-0.75				●				●	●													
 Wiper	WNMG 080408 WS	0.5-2.0	0.07-0.35					●		●	●														
 Wiper Medium	WNMG 060408 WT	0.7-3.5	0.15-0.60								●							●							
	060412 WT	0.7-3.5	0.20-0.80					●			●														
	080408 WT	1.0-4.0	0.15-0.60					●			●	●						●							
	080412 WT	1.0-4.0	0.20-0.80					●	●		●	●	●												

A57, A69, A109,
A149, A169,
A198, A207

▶ ✓: Type B chip breaker

●: Standard items



Negative rhombic inserts with 80° corner angle

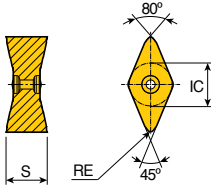

Size	Dimension (mm)		
	IC	S	RE
14	10.5	10	0.8

Insert	Designation	BWT		FWT		CVD coated						PVD coated				K10								
		ap (mm)	Feed (mm/rev)	ap (mm)	Feed (mm/rev)	TT3005	TT7005	TT7015	TT7025	TT8105B	TT8115B	TT8125B	TT8135B	TT9215	TT9225		TT9235	TT5080	TT8020	TT9080	TT3010	TT3020	TT9020	
Medium	ZNMV 141008-BM	0.5-2.5	0.40-1.00	0.5-2.0	0.20-0.60					●	●	●												
Medium	ZNMV 141008-BS	0.5-2.5	0.50-1.00	1.0-2.0	0.20-0.40	●				●	●	●								●	●			



A112, A150

- ▶ BWT: Backward turning
- ▶ FWT: Forward turning

●: Standard items

ZNMV Y-BF

Negative rhombic inserts with 35° corner angle

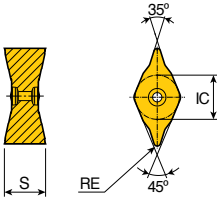

Size	Dimension (mm)		
	IC	S	RE
14	10.5	10	0.8

Insert	Designation	BWT		FWT		CVD coated						PVD coated				K10								
		ap (mm)	Feed (mm/rev)	ap (mm)	Feed (mm/rev)	TT3005	TT7005	TT7015	TT7025	TT8105B	TT8115B	TT8125B	TT8135B	TT9215	TT9225		TT9235	TT5080	TT8020	TT9080	TT3010	TT3020	TT9020	
Finishing	ZNMV 141008Y-BF	0.25-1.5	0.20-0.50	0.25-1.0	0.20-0.35	●					●	●	●											



A113, A213

- ▶ BWT: Backward turning
- ▶ FWT: Forward turning

●: Standard items

Positive 7° clearance 80° rhombic inserts

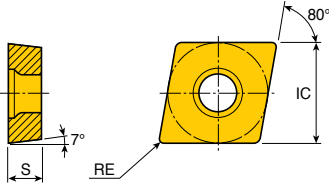

Size	Dimension (mm)		
	IC	S	RE
06	6.35	2.38	0.03-0.8
09	9.52	3.97	0.03-0.8

Insert	Designation	ap (mm)	Feed (mm/rev)	Cermet		PVD coated								Uncoated				
				PV3010	CT3000	TT5080	TT8020	TT9080	TT3010	TT3020	TT9020	TT4410	TT4430	P20	K10			
 Right hand Finishing	CCET 0602003 L-GF	0.1-1.5	0.02-0.15															
	0602003 R-GF	0.1-1.5	0.02-0.15															
	060201 L-GF	0.2-1.5	0.02-0.15															
	060201 R-GF	0.2-1.5	0.02-0.15															
	060202 L-GF	0.3-1.5	0.03-0.17															
	060202 R-GF	0.3-1.5	0.03-0.17															
	060204 L-GF	0.3-1.5	0.05-0.20															
	060204 R-GF	0.3-1.5	0.05-0.20															
	060208 L-GF	0.4-1.5	0.07-0.22															
	060208 R-GF	0.4-1.5	0.07-0.22															
	09T3003 L-GF	0.1-2.5	0.02-0.15															
	09T3003 R-GF	0.1-2.5	0.02-0.15															
	09T301 L-GF	0.2-2.5	0.02-0.15															
	09T301 R-GF	0.2-2.5	0.02-0.15															
	09T302 L-GF	0.3-2.5	0.03-0.17															
	09T302 R-GF	0.3-2.5	0.03-0.17															
	09T304 L-GF	0.3-2.5	0.05-0.20															
	09T304 R-GF	0.3-2.5	0.05-0.20															
09T308 L-GF	0.4-2.5	0.07-0.22																
09T308 R-GF	0.4-2.5	0.07-0.22																
 Right hand Finishing	CCET 0602003 L-GW*	0.1-1.5	0.02-0.15															
	0602003 R-GW*	0.1-1.5	0.02-0.15															
	09T3003 L-GW*	0.1-2.5	0.02-0.15															
	09T3003 R-GW*	0.1-2.5	0.02-0.15															

A70-A72, A94,
 A151, A174,
 A175, A208

▶ *: Wiper inserts should be applied to
 CLCR/L...

●: Standard items

Positive 7° clearance 80° rhombic inserts

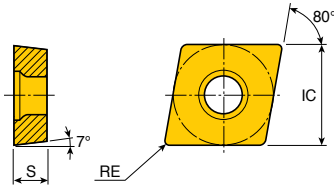

Size	Dimension (mm)		
	IC	S	RE
03	3.5	1.4	0.03-0.4
04	4.3	1.8	0.03-0.4
06	6.35	2.38	0.1-0.4
09	9.52	3.97	0.1-0.8
12	12.7	4.76	0.2-0.8

Insert	Designation	ap (mm)	Feed (mm/rev)	Cermet								PVD coated		Uncoated					
				PV3010	CT3000	TT5080	TT8020	TT9080	TT3010	TT3020	TT9020	TT4410	TT4430	P20	K10				
 Right hand Finishing	CCGT 0301003 L-FF	0.05-0.3	0.03-0.10																
	0301003 R-FF	0.05-0.3	0.03-0.10																
	030101 L-FF	0.08-0.4	0.03-0.12																
	030101 R-FF	0.08-0.4	0.03-0.12																
	030102 L-FF	0.1-0.4	0.03-0.15																
	030102 R-FF	0.1-0.4	0.03-0.15																
	030104 L-FF	0.1-0.4	0.05-0.20																
	030104 R-FF	0.1-0.4	0.05-0.20																
	0401003 L-FF	0.05-0.4	0.03-0.10																
	0401003 R-FF	0.05-0.4	0.03-0.10																
	040101 L-FF	0.1-0.5	0.03-0.12																
	040101 R-FF	0.1-0.5	0.03-0.12																
	040102 L-FF	0.1-0.5	0.03-0.15																
	040102 R-FF	0.1-0.5	0.03-0.15																
	040104 L-FF	0.1-0.5	0.05-0.20																
040104 R-FF	0.1-0.5	0.05-0.20																	
 Medium For aluminum	CCGT 060202 FL	0.5-2.0	0.10-0.20															●	
	060204 FL	0.5-2.0	0.10-0.25																●
	09T301 FL	0.5-2.5	0.10-0.25																●
	09T302 FL	0.5-2.5	0.10-0.25																●
	09T304 FL	0.5-2.5	0.10-0.25																●
	09T308 FL	0.8-3.0	0.10-0.30																●
	120402 FL	0.5-2.5	0.10-0.25																●
	120404 FL	0.5-2.5	0.10-0.25																●
120408 FL	1.0-3.5	0.10-0.30																●	
 Finishing	CCGT 060201 SA	0.1-1.5	0.02-0.15					●						●					
	060202 SA	0.1-1.5	0.02-0.15					●						●					
	060204 SA	0.1-2.4	0.03-0.20					●						●					
	09T301 SA	0.1-2.5	0.02-0.15					●						●					
	09T302 SA	0.1-2.5	0.02-0.15					●						●					
	09T304 SA	0.1-2.5	0.03-0.20					●	●					●					
	09T308 SA	0.1-2.5	0.03-0.25					●						●					

A70-A72, A94,
 A151, A174,
 A175, A208

●: Standard items



Positive 7° clearance 80° rhombic inserts

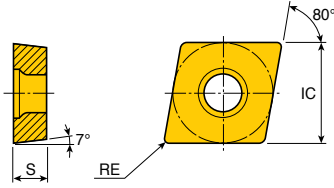

Size	Dimension (mm)		
	IC	S	RE
06	6.35	2.38	0.2
09	9.52	3.97	0.1-0.4

Insert	Designation	ap (mm)	Feed (mm/rev)	Cermet		PVD coated								Uncoated			
				PV3010	CT3000	TT5080	TT8020	TT9080	TT3010	TT3020	TT9020	TT4410	TT4430	P20	K10		
 Roughing For Swiss	CCGT 09T304M SH-F	0.7-3.5	0.07-0.17										●	●			
 Medium For Swiss	CCGT 060202M SM-F	0.2-1.5	0.02-0.12										●	●			
	09T301M SM-F	0.2-1.5	0.02-0.12											●	●		
	09T302M SM-F	0.2-1.5	0.02-0.12											●	●		
	09T304M SM-F	0.3-1.5	0.03-0.12											●	●		
 Finishing For Swiss	CCGT 060202M SL-F	0.02-0.2	0.02-0.10										●	●			
	09T301M SL-F	0.02-0.2	0.015-0.10											●	●		
	09T302M SL-F	0.02-0.2	0.02-0.10											●	●		

A70-A72, A94,
 A151, A174,
 A175, A208

▶ M: Corner radius minus tolerance
 ▶ - F: Sharp edge

●: Standard items

Positive 7° clearance 80° rhombic inserts

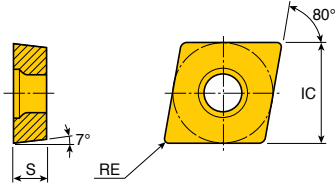

Size	Dimension (mm)		
	IC	S	RE
06	6.35	2.38	0.2-0.8
09	9.52	3.97	0.2-0.8
12	12.7	4.76	0.4-1.2

Insert	Designation	ap (mm)	Feed (mm/rev)	Coating																						
				Cermat		CVD coated							PVD coated													
				PV3010	CT3000	TT3005	TT7005	TT7015	TT7025	TT8105B	TT8115B	TT8125B	TT8135B	TT9215	TT9225	TT9235	TT5100	TT7100	TT5080	TT8020	TT9080	TT3010	TT3020	TT9020	K10	
Finishing	CCMT060202 FA	0.1-1.5	0.03-0.15	●	●										●	●			●	●						
	060204 FA	0.2-1.5	0.05-0.15	●	●						●				●	●			●	●						
	09T302 FA	0.1-2.0	0.03-0.15	●	●										●	●			●	●		●				
	09T304 FA	0.2-2.0	0.05-0.20	●	●							●				●	●			●	●					
	09T308 FA	0.3-2.0	0.08-0.25	●	●							●				●	●			●	●					
Type B Finishing	CCMT060204 FG	0.3-1.5	0.05-0.15	●	●	●	●			●	●	●		●	●	●			●	●	●	●	●			
	09T304 FG	0.4-2.0	0.07-0.20	●	●	●	●			●	●	●		●	●	●			●	●	●	●	●			
	09T308 FG	0.6-2.0	0.10-0.25	●	●	●	●			●	●	●		●	●	●			●	●	●	●	●			
	120408 FG ✓	0.6-2.0	0.10-0.25	●							●					●				●	●					
Medium	CCMT060202 FM	0.5-1.5	0.07-0.15								●	●					●		●	●						
	060204 FM	0.5-1.5	0.08-0.15								●	●					●		●	●						
	09T302 FM	0.5-2.0	0.07-0.20								●	●					●		●	●						
	09T304 FM	0.5-2.5	0.08-0.25								●	●					●		●	●						
	09T308 FM	0.8-2.5	0.10-0.25								●	●					●		●	●						
Type B Medium	CCMT060204 MT ✓	0.5-2.0	0.07-0.20	●	●	●	●			●	●	●	●	●	●	●			●	●	●	●	●		●	
	060208 MT ✓	0.7-2.0	0.13-0.30	●	●	●	●			●	●	●	●	●	●	●			●	●	●	●	●			
	09T304 MT	0.7-3.5	0.10-0.25	●	●	●	●			●	●	●	●	●	●	●			●	●	●	●	●			
	09T308 MT	1.0-3.5	0.13-0.30	●	●	●	●			●	●	●	●	●	●	●			●	●	●	●	●			
	120404 MT ✓	1.0-5.0	0.10-0.25	●	●	●	●			●	●	●	●	●	●	●			●	●	●	●	●			
	120408 MT	1.3-5.0	0.13-0.30	●	●	●	●			●	●	●	●	●	●	●			●	●	●	●	●			
	120412 MT	1.5-5.0	0.17-0.35			●					●	●					●			●	●					
Medium	CCMT060204 PC	0.3-2.0	0.06-0.18								●	●	●	●						●	●					
	060208 PC	0.4-2.0	0.08-0.25								●	●	●	●						●	●					
	09T304 PC	0.35-3.0	0.08-0.25								●	●	●	●						●	●					
	09T308 PC	0.5-3.0	0.10-0.28								●	●	●	●						●	●					
	120404 PC	0.4-4.0	0.08-0.25								●	●	●	●						●	●					
	120408 PC	0.7-4.0	0.10-0.30								●	●	●	●						●	●					
	120412 PC	1.0-4.0	0.12-0.35								●	●	●	●						●	●					
Wiper Medium	CCMT09T308 WT *	0.7-3.0	0.10-0.40			●					●	●					●		●	●						

A70-A72, A94,
A151, A154, A174,
A175, A208

▶ ✓: Type B chip breaker
▶ *: Wiper inserts should be applied to
□ CLCR/L...

●: Standard items



Positive 11° clearance 80° rhombic inserts

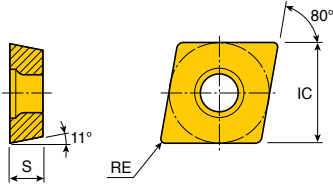

Size	Dimension (mm)		
	IC	S	RE
06	6.35	2.38	0.4-0.8
08	7.94	2.38	0.4-0.8
09	9.52	3.18-3.97	0.4-0.8

Insert	Designation	ap (mm)	Feed (mm/rev)	Coating																						
				Cermet		CVD coated								PVD coated			K10									
				PV3010	CT3000	TT3005	TT7005	TT7015	TT7025	TT8105B	TT8115B	TT8125B	TT8135B	TT9215	TT9225	TT9235		TT15100	TT17100	TT15080	TT18020	TT19080	TT3010	TT3020	TT9020	
 Finishing	CPMT 080204 FG	0.4-1.5	0.07-0.20	●									●				●									
	080208 FG	0.6-1.5	0.10-0.25	●									●				●									
	090304 FG	0.4-2.0	0.07-0.20	●									●				●									
	090308 FG	0.6-2.0	0.10-0.25	●									●	●			●									
 Medium	CPMT 080204 FM	0.5-2.0	0.08-0.20									●	●				●		●	●						
	080208 FM	0.8-2.0	0.10-0.20									●	●				●		●	●						
	090304 FM	0.5-2.5	0.08-0.25									●	●				●		●	●						
	090308 FM	0.8-2.5	0.10-0.25									●	●				●		●	●						
 Medium	CPMT 060204 PC	0.3-2.0	0.06-0.18				●	●						●	●		●		●							
	060208 PC	0.4-2.0	0.08-0.25					●						●	●		●		●							
	090304 PC	0.45-3.0	0.08-0.25										●	●	●		●		●							
	090308 PC	0.6-3.0	0.10-0.30										●	●	●		●		●							
	09T304 PC	0.45-3.0	0.08-0.25										●	●			●				●					
	09T308 PC	0.6-3.0	0.10-0.30				●	●					●	●	●		●		●							

A176, A177

● Standard items



Positive 7° clearance 55° rhombic inserts

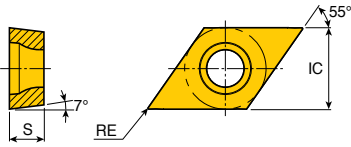

Size	Dimension (mm)		
	IC	S	RE
07	6.35	2.38	0.03-0.8
11	9.52	3.97	0.03-0.8

Insert	Designation	ap (mm)	Feed (mm/rev)	Cermet										PVD coated		Uncoated		
				PV3010	CT3000	TT5080	TT8020	TT9080	TT3010	TT3020	TT9020	TT4410	TT4430	P20	K10			
 Right hand Finishing	DCET 0702003 L-GF	0.2-1.5	0.01-0.15															
	0702003 R-GF	0.2-1.5	0.01-0.15															
	070201 L-GF	0.2-1.5	0.02-0.15															
	070201 R-GF	0.2-1.5	0.02-0.15															
	070202 L-GF	0.3-1.5	0.03-0.17															
	070202 R-GF	0.3-1.5	0.03-0.17															
	070204 L-GF	0.3-1.5	0.05-0.20															
	070204 R-GF	0.3-1.5	0.05-0.20															
	070208 L-GF	0.3-1.5	0.05-0.20															
	070208 R-GF	0.3-1.5	0.05-0.20															
	11T3003 L-GF	0.2-2.5	0.02-0.15															
	11T3003 R-GF	0.2-2.5	0.02-0.15															
	11T301 L-GF	0.2-2.5	0.02-0.15															
	11T301 R-GF	0.2-2.5	0.02-0.15															
	11T302 L-GF	0.3-2.5	0.03-0.17															
	11T302 R-GF	0.3-2.5	0.03-0.17															
11T304 L-GF	0.3-2.5	0.05-0.20																
11T304 R-GF	0.3-2.5	0.05-0.20																
11T308 L-GF	0.3-2.5	0.05-0.20																
11T308 R-GF	0.3-2.5	0.05-0.20																
 wiper	DCET 0702003 L-GW *	0.1-1.5	0.02-0.15															
	0702003 R-GW *	0.1-1.5	0.02-0.15															
	11T3003 L-GW *	0.1-1.5	0.02-0.15															
	11T3003 R-GW *	0.1-1.5	0.02-0.15															
Right hand Finishing																		

A73-A76, A95, A97, A99, A137, A141, A151, A178-A180, A209, A214

▶ *: FWiper inserts should be applied to
DJCR/L..., DUCR/L..., DZCR/L...

●*: Standard items

Positive 7° clearance 55° rhombic inserts

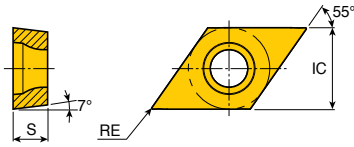

Size	Dimension (mm)		
	IC	S	RE
07	6.35	2.38	0.03-0.4
11	9.52	3.97	0.03-0.8

Insert	Designation	ap (mm)	Feed (mm/rev)	Cermet		PVD coated								Uncoated						
				PV3010	CT3000	TT5080	TT8020	TT9080	TT3010	TT3020	TT9020	TT4410	TT4430	P20	K10					
 Right hand Finishing	DCGT 0702003 L-FF	0.05-0.3	0.03-0.10																	
	0702003 R-FF	0.05-0.3	0.03-0.10																	
	070201 L-FF	0.08-0.4	0.03-0.12																	
	070201 R-FF	0.08-0.4	0.03-0.12																	
	070202 L-FF	0.1-0.4	0.03-0.15																	
	070202 R-FF	0.1-0.4	0.03-0.15																	
	070204 L-FF	0.1-0.4	0.05-0.20																	
	070204 R-FF	0.1-0.4	0.05-0.20																	
	11T3003 L-FF	0.05-0.4	0.03-0.10																	
	11T3003 R-FF	0.05-0.4	0.03-0.10																	
	11T301 L-FF	0.1-0.5	0.03-0.12																	
	11T301 R-FF	0.1-0.5	0.03-0.12																	
	11T302 L-FF	0.1-0.5	0.03-0.15																	
	11T302 R-FF	0.1-0.5	0.03-0.15																	
	11T304 L-FF	0.1-0.5	0.05-0.20																	
11T304 R-FF	0.1-0.5	0.05-0.20																		
 Medium For aluminum	DCGT 070202 FL	0.5-2.0	0.05-0.20															●		
	070204 FL	0.5-2.5	0.05-0.25																●	
	11T302 FL	0.5-2.5	0.05-0.25																●	
	11T304 FL	0.5-2.5	0.05-0.25																●	
	11T308 FL	0.8-3.0	0.08-0.30																●	
 Finishing	DCGT 070201 SA	0.1-1.5	0.02-0.15																●	
	070202 SA	0.1-1.5	0.02-0.15																	●
	070204 SA	0.1-1.5	0.03-0.20																	●
	11T301 SA	0.1-2.5	0.01-0.05																	●
	11T302 SA	0.1-2.5	0.02-0.15																	●
	11T304 SA	0.1-2.5	0.03-0.20																	●
	11T308 SA	0.1-2.5	0.03-0.20																	●

● Standard items

A73-A76, A95, A97, A99,
 A137, A141, A151,
 A178-A180, A209, A214

Positive 7° clearance 55° rhombic inserts

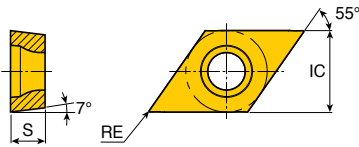

Size	Dimension (mm)		
	IC	S	RE
07	6.35	2.38	0.1-0.4
11	9.52	3.97	0.1-0.4

Insert	Designation	ap (mm)	Feed (mm/rev)	Coating											
				Cermet		PVD coated								Uncoated	
				PV3010	CT3000	TT5080	TT8020	TT9080	TT3010	TT9020	TT9225	TT4410	TT4430	P20	K10
 Roughing For Swiss	DCGT 11T302M SH-E	0.7-3.5	0.05-0.15												●
	11T302M SH-F	0.7-3.5	0.05-0.15									●	●		
	11T304M SH-F	0.7-3.5	0.07-0.17										●	●	
 Roughing For Swiss	DCGT 11T301M ST-E	0.3-5.0	0.03-0.08												●
	11T302M ST-E	0.5-5.0	0.03-0.10												●
	11T304M ST-E	0.7-5.0	0.05-0.12												●
	11T301M ST-F	0.3-5.0	0.03-0.08								●				●
	11T302M ST-F	0.5-5.0	0.03-0.10								●				●
	11T304M ST-F	0.7-5.0	0.05-0.12								●				●
 Medium For Swiss	DCGT 070201M SM-F	0.2-1.5	0.02-0.12									●	●		
	070202M SM-F	0.2-1.5	0.02-0.12									●	●		
	070204M SM-F	0.2-1.5	0.03-0.12									●	●		
	11T301M SM-F	0.2-1.5	0.02-0.12									●	●		
	11T302M SM-F	0.2-1.5	0.02-0.12									●	●		
	11T304M SM-F	0.2-1.5	0.03-0.12										●	●	
 Finishing For Swiss	DCGT 070201M SL-F	0.02-0.25	0.015-0.10									●	●		
	070202M SL-F	0.02-0.25	0.02-0.10									●	●		
	11T301M SL-F	0.02-0.25	0.015-0.10									●	●		
	11T302M SL-F	0.02-0.25	0.02-0.10									●	●		

A73-A76, A95, A97, A99, A137, A141, A151, A178-A180, A209, A214

- ▶ M: Corner radius minus tolerance
- ▶ - F: Sharp edge
- ▶ - E: Micro honing edge

●: Standard items

Positive 7° clearance 55° rhombic inserts

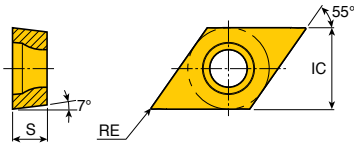

Size	Dimension (mm)		
	IC	S	RE
07	6.35	2.38	0.2-0.8
11	9.52	3.97	0.2-1.2

Insert	Designation	ap (mm)	Feed (mm/rev)	Coating																		
				Cermet	CVD coated							PVD coated					K10					
				PV3010	CT3000	TT3005	TT7015	TT7025	TT8105B	TT8115B	TT8125B	TT8135B	TT9215	TT9235	TT15100	TT17100		TT18020	TT19080	TT3010	TT3020	TT9020
Finishing	DCMT 070202 FA	0.1-1.5	0.03-0.15	●	●										●		●	●				
	070204 FA	0.2-1.5	0.05-0.20	●	●					●	●						●	●				
	11T302 FA	0.1-2.0	0.03-0.15	●	●								●		●		●	●				
	11T304 FA	0.2-2.0	0.05-0.20	●	●					●	●						●	●				
	11T308 FA	0.3-2.0	0.08-0.25	●	●					●	●					●	●					
Finishing	DCMT 070204 FG	0.4-1.5	0.07-0.20	●	●				●	●	●			●	●	●	●	●				
	070208 FG	0.4-2.0	0.07-0.20	●	●				●	●				●	●		●					
	11T304 FG	0.6-1.5	0.10-0.25	●	●	●	●		●	●			●	●	●	●	●	●	●	●		
	11T308 FG	0.6-2.0	0.10-0.25	●	●	●	●		●	●			●	●	●	●	●	●	●	●		
Medium	DCMT 070202 FM	0.5-1.5	0.07-0.20						●	●					●		●	●				
	070204 FM	0.5-1.5	0.08-0.20						●	●				●	●	●	●	●				
	070208 FM	0.8-1.5	0.10-0.20						●	●				●	●		●	●				
	11T302 FM	0.5-2.0	0.07-0.20						●	●				●	●		●	●				
	11T304 FM	0.5-2.0	0.08-0.20						●	●				●	●		●	●				
	11T308 FM	0.8-2.5	0.10-0.25						●	●				●	●		●	●				
Medium	DCMT 11T304 MT	0.7-3.0	0.10-0.25	●	●		●	●	●	●	●			●	●		●	●				
	11T308 MT	1.0-3.0	0.13-0.30	●		●	●	●	●	●				●	●		●	●	●			
	11T312 MT	1.5-3.0	0.17-0.35	●		●	●		●					●			●	●				
Medium	DCMT 070204 PC	0.3-2.0	0.06-0.18						●	●			●	●				●				
	070208 PC	0.4-2.0	0.08-0.25						●	●			●	●				●				
	11T304 PC	0.35-3.0	0.08-0.25						●	●			●	●				●				
	11T308 PC	0.5-3.0	0.10-0.28						●	●			●	●				●				
	11T312 PC	0.5-3.0	0.12-0.32						●	●			●	●				●				

● Standard items



A73-A76, A95, A97, A99,
A137, A141, A151, A154,
A178-A180, A209, A214

DPET DPGT



Positive 11° clearance 55° rhombic inserts

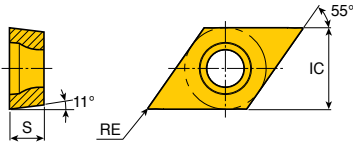

Size	Dimension (mm)		
	IC	S	RE
07	6.35	2.38	0.03-0.2
11	9.52	3.97	0.03-0.2

Insert	Designation	ap (mm)	Feed (mm/rev)	Cermet		PVD coated								Uncoated			
				PV3010	CT3000	TT5080	TT8020	TT9080	TT3010	TT3020	TT9020	TT4410	TT4430	P20	K10		
<p>Right hand Finishing</p>	DPET 070201 R-GF	0.2-1.5	0.02-0.15														
	070202 L-GF	0.3-1.5	0.03-0.17														
	070202 R-GF	0.3-1.5	0.03-0.17														
	11T3003 L-GF	0.2-2.5	0.02-0.15														
	11T301 L-GF	0.2-2.5	0.02-0.15														
	11T301 R-GF	0.2-2.5	0.02-0.15														
	11T302 L-GF	0.3-2.5	0.03-0.17														
	11T302 R-GF	0.3-2.5	0.03-0.17														
<p>Right hand Finishing</p>	DPGT 0702003 R-FF	0.05-0.3	0.03-0.10														
	070202 L-FF	0.1-0.4	0.03-0.15														
	070202 R-FF	0.1-0.4	0.03-0.15														
	11T3003 R-FF	0.05-0.4	0.03-0.10														
	11T301 R-FF	0.1-0.5	0.03-0.12														
	11T302 L-FF	0.1-0.5	0.03-0.15														
	11T302 R-FF	0.1-0.5	0.03-0.15														

●: Standard items

Positive 7° clearance high feed inserts

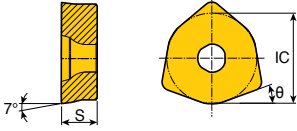

Size	Dimension (mm)		
	IC	S	θ
10-HFG	15.45	6.5	15°
10-HFP	16.45	6.5	20°

Insert	Designation	ap (mm)	Feed (mm/rev)	Coating																						
				Cermet		CVD coated										PVD coated										
				PV3010	CT3000	TT3005	TT7005	TT7015	TT7025	TT8105B	TT8115B	TT8125B	TT8135B	TT9215	TT9225	TT9235	TT5100	TT7100	TT5080	TT8020	TT9080	TT3010	TT3020	TT9020	K10	
 High feed For general	FCMX 100616-HFG	0.5-2.0	1.50-3.00										●	●		●										
 High feed For alloy steel	FCMX 100616-HFP	0.5-2.5	1.00-2.50										●	●	●											

● Standard items







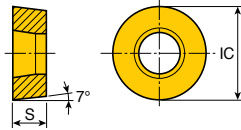

RCGT RCMT RCMX



Positive 7° clearance round inserts



Size	Dimension (mm)		Size	Dimension (mm)	
	IC	S		IC	S
08	8.0	3.18	20	20.0	6.35
10	10.0	3.18-3.97	25	25.0	7.94
12	12.0	4.76	32	32.0	9.52
16	16.0	6.35			

Insert	Designation	ap (mm)	Feed (mm/rev)	Cermat		CVD coated										PVD coated									
				PV3010	CT3000	TT3005	TT7005	TT7015	TT7025	TT8105B	TT8115B	TT8125B	TT8135B	TT9215	TT9225	TT9235	TT5100	TT7100	TT5080	TT8020	TT9080	TT3010	TT3020	TT9020	K10
 Medium For aluminum	RCGT 0803MO FL	1.0-4.0	0.20-0.40																						●
	1003MO FL	1.0-5.0	0.20-0.40																						●
	10T3MO FL	1.0-5.0	0.20-0.40																						●
 Medium	RCMT 080300 MGS	0.5-2.0	0.15-0.30			●																			● ● ●
	120400 MGS	1.0-3.0	0.25-0.50			●																			● ● ●
 Medium	RCMT 080300 MT	0.5-3.0	0.15-0.40																						
	10T300 MT	1.0-4.0	0.20-0.50					● ●																	
	120400 MT	2.0-5.0	0.30-0.60					● ●																	
	160600 MT	3.0-7.0	0.40-0.80																						
 Medium	RCMT 120400 PC	2.0-5.0	0.30-0.60																						
 Roughing	RCMX 100300	1.5-4.0	0.25-0.50					● ●																	●
	120400	2.5-5.0	0.30-0.60					● ●																	
	160600	3.0-7.0	0.40-0.75					● ●																	
	200600	3.5-9.0	0.48-0.90					● ●																	●
	250700	4.0-12.0	0.55-1.20					● ● ● ●																	●
	320900	5.0-15.0	0.65-1.50					●																	●
 Roughing	RCMX 100300 RA	1.0-4.0	0.20-0.50																						
	120400 RA	2.0-5.0	0.25-0.60																						
	160600 RA	2.5-7.0	0.35-0.75																						
	200600 RA	3.0-9.0	0.40-0.90					●																	
	250700 RA	3.5-12.0	0.50-1.20																						
	320900 RA	4.0-15.0	0.60-1.50																						

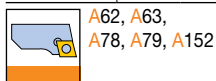

●: Standard items

Positive 7° clearance square inserts

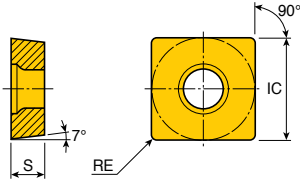

Size	Dimension (mm)		
	IC	S	RE
09	9.52	3.97	0.4-0.8
12	12.7	4.76	0.2-1.2

Insert	Designation	ap (mm)	Feed (mm/rev)	Coating																						
				Cermat			CVD coated							PVD coated												
				PV3010	CT3000	TT3005	TT7005	TT7015	TT7025	TT8105B	TT8115B	TT8125B	TT8135B	TT9215	TT9235	TT15100	TT7100	TT5080	TT8020	TT9080	TT3010	TT3020	TT9020	K10		
 Medium For aluminum	SCGT 09T308 FL	0.5-3.0	0.10-0.30																						●	
	120402 FL	0.5-3.0	0.10-0.30																							●
	120404 FL	0.5-4.0	0.10-0.30																							●
	120408 FL	1.0-4.0	0.10-0.30																							●
 Finishing	SCMT 09T304 FG	0.6-2.0	0.08-0.25								●			●												
	09T308 FG	0.6-2.0	0.10-0.25								●	●		●	●			●	●							
 Medium	SCMT 09T304 FM	0.5-2.5	0.08-0.25								●	●				●			●	●						
	09T308 FM	0.8-2.5	0.10-0.25								●	●				●			●	●						
 Medium	SCMT 09T304 MT	0.7-3.5	0.10-0.25	●	●					●	●			●	●				●							
	09T308 MT	1.0-3.5	0.13-0.30	●	●	●	●			●	●	●		●	●	●	●	●	●	●						
	120404 MT	1.0-5.0	0.10-0.25	●	●	●				●	●					●										
	120408 MT	1.0-5.0	0.13-0.30	●	●	●	●			●	●	●		●	●	●			●	●						
	120412 MT	1.0-5.0	0.15-0.35				●	●		●	●									●						
 Medium	SCMT 09T304 PC	0.35-3.0	0.08-0.25								●	●		●							●					
	09T308 PC	0.5-3.0	0.10-0.28								●	●		●	●						●					
	120404 PC	0.4-4.0	0.08-0.25								●	●			●						●					
	120408 PC	0.7-4.0	0.10-0.30								●	●		●	●						●					
	120412 PC	1.0-4.0	0.12-0.35								●	●		●	●						●					



● Standard items





TCET TCGT

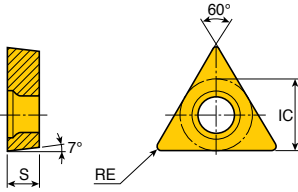

Positive 7° clearance triangular inserts



Size	Dimension (mm)		
	IC	S	RE
08	4.76	2.38	0.1-0.2
09	5.56	2.36	0.4
11	6.35	2.38-3.18	0.1-0.4
16	9.52	3.97	0.4-0.8

Insert	Designation	ap (mm)	Feed (mm/rev)	Cermet		PVD coated								Uncoated					
				PV3010	CT3000	TT5080	TT8020	TT9080	TT3010	TT3020	TT9020	TT4410	TT4430	P20	K10				
  Right hand Finishing	TCET 080201 R-GF	0.2-1.5	0.02-0.15																
	080202 L-GF	0.3-1.5	0.03-0.17																
	080202 R-GF	0.3-1.5	0.03-0.17																
	110301 L-GF	0.2-1.5	0.02-0.15																
	110301 R-GF	0.2-1.5	0.02-0.15																
	110302 L-GF	0.3-1.5	0.03-0.17																
	110302 R-GF	0.3-1.5	0.03-0.17																
	110304 L-GF	0.5-1.5	0.05-0.20																
	110304 R-GF	0.5-1.5	0.05-0.20																
 Medium For aluminum	TCGT 090204 FL	0.2-2.5	0.05-0.25																
	110204 FL	0.2-3.0	0.05-0.30																
	16T304 FL	0.5-3.0	0.05-0.30																
	16T308 FL	0.5-3.0	0.10-0.30																
  Finishing	TCGT 110201 SA	0.1-2.5	0.01-0.05																
	110202 SA	0.2-2.5	0.02-0.15																
	110204 SA	0.2-2.5	0.03-0.20																

 A81-A83,
 A152, A155,
 A182, A210,

● Standard items

Positive 7° clearance triangular inserts

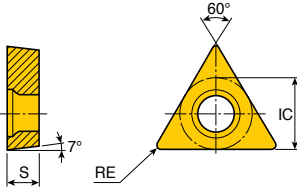

Size	Dimension (mm)		
	IC	S	RE
06	3.97	1.98	0.2
09	5.56	2.38	0.2-0.8
11	6.35	2.38	0.2-0.8
16	9.52	3.97	0.4-1.2
22	12.7	4.76	0.8

Insert	Designation	ap (mm)	Feed (mm/rev)	Coating																					
				Cermet	CVD coated										PVD coated										
				PV3010	CT3000	TT3005	TT7005	TT7015	TT7025	TT8105B	TT8115B	TT8125B	TT8135B	TT9215	TT9225	TT9235	TT15100	TT7100	TT5080	TT8020	TT9080	TT3010	TT3020	TT9020	K10
Finishing	TCMT 06T102 FA	0.4-1.2	0.03-0.15	●													●								
	110202 FA	0.1-1.5	0.03-0.15	●							●								●		●				
	110204 FA	0.1-1.5	0.05-0.15	● ●							●							●							
Finishing	TCMT 090208 FG	0.6-1.5	0.10-0.25	● ●						● ●							●								
	110204 FG	0.4-1.5	0.07-0.20	● ●						●				● ● ●					● ●						
	110208 FG	0.6-1.5	0.10-0.25	● ●	● ●					● ●				● ● ●					●		● ●				
	16T304 FG	0.4-2.0	0.07-0.20	● ●	●					●				●						●					
	16T308 FG	0.6-2.0	0.10-0.25	● ●	● ●					● ●				● ● ●						● ●		● ●			
Medium	TCMT 090202 FM	0.5-1.5	0.07-0.20							● ●							●			● ●					
	090204 FM	0.5-1.5	0.08-0.20							● ●							●			● ●					
	110202 FM	0.5-1.5	0.07-0.20							● ●							●			● ●					
	110204 FM	0.5-1.5	0.08-0.20							● ●							●			● ●					
	110208 FM	0.8-1.5	0.10-0.20							● ●							●			● ●					
	16T304 FM	0.5-2.0	0.08-0.20							● ●							●			● ●					
	16T308 FM	0.8-2.0	0.10-0.20							● ●							●			● ●					
16T312 FM	1.0-2.5	0.10-0.25							● ●							●			● ●						
Medium <small>Type B</small>	TCMT 090204 MT	0.6-2.0	0.10-0.25	● ●	● ●					● ●				● ● ●				● ●		● ●					
	090208 MT	0.8-2.0	0.13-0.30	●	● ●					● ●				● ● ●				● ●		● ●					
	110204 MT	0.6-3.0	0.10-0.25	●	● ●					● ●				● ● ●				● ●		● ●				●	
	110208 MT	0.8-3.0	0.13-0.30	● ●	● ●					● ●				● ● ●				● ●		● ●				●	
	16T304 MT	0.8-5.0	0.10-0.25	●	● ●					● ●	●			● ● ●				● ●		● ●					●
	16T308 MT	1.0-5.0	0.10-0.30	● ●	● ●				●	● ●	● ●	●		● ● ●				● ●		● ●					●
	16T312 MT	1.5-5.0	0.10-0.30		●					●	● ●			● ● ●				● ●		● ●					●
	220408 MT	2.0-6.0	0.10-0.35								● ●			● ● ●				● ●		● ●					●
Medium	TCMT 090204 PC	0.3-2.0	0.06-0.18							● ●			● ●							●					
	090208 PC	0.4-2.0	0.08-0.25							● ●			● ●							●					
	110204 PC	0.3-2.5	0.06-0.20							● ●			● ●							●					
	110208 PC	0.42-2.5	0.09-0.26							● ●			● ●							●					
	16T304 PC	0.35-3.0	0.08-0.25							● ●			● ●							●					
	16T308 PC	0.5-3.0	0.10-0.28							● ●			● ●							●					
16T312 PC	0.6-3.0	0.12-0.36							● ●			● ●							●						

A81-A83, A152, A182, A210

▶ ✓: Type B chip breaker

●: Standard items



TPET TPGT

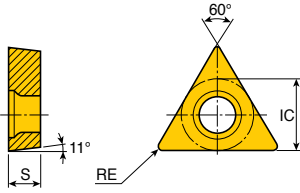

Positive 11° clearance triangular inserts



Size	Dimension (mm)		
	IC	S	RE
08	4.76	2.38	0.03-0.2
11	6.35	3.18	0.03-0.2

Insert	Designation	ap (mm)	Feed (mm/rev)	Cermet		PVD coated								Uncoated			
				PV3010	CT3000	TT5080	TT8020	TT9080	TT3010	TT3020	TT9020	TT4410	TT4430	P20	K10		
 Right hand Finishing	TPET 080201 L-GF	0.2-1.5	0.02-0.15														
	080201 R-GF	0.2-1.5	0.02-0.15														
	080202 L-GF	0.3-1.5	0.03-0.17														
	080202 R-GF	0.3-1.5	0.03-0.17														
	110301 L-GF	0.2-1.5	0.02-0.15														
	110302 L-GF	0.3-1.5	0.03-0.17														
	110302 R-GF	0.3-1.5	0.03-0.17														
 Right hand Finishing	TPGT 0802003 L-FF	0.05-0.3	0.03-0.10														
	0802003 R-FF	0.05-0.3	0.03-0.10														
	080201 L-FF	0.08-0.4	0.03-0.12														
	080201 R-FF	0.08-0.4	0.03-0.12														
	080202 L-FF	0.1-0.4	0.03-0.15														
	080202 R-FF	0.1-0.4	0.03-0.15														
	1103003 L-FF	0.05-0.4	0.03-0.10														
	1103003 R-FF	0.05-0.4	0.03-0.10														
	110301 L-FF	0.1-0.5	0.03-0.12														
	110301 R-FF	0.1-0.5	0.03-0.12														
	110302 L-FF	0.1-0.5	0.03-0.15														
	110302 R-FF	0.1-0.5	0.03-0.15														

A82, A183, A184

● Standard items



TPGN TPGT TPGX



Positive 11° clearance triangular inserts

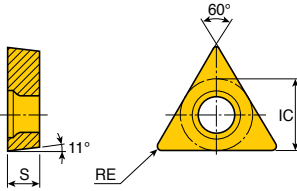

Size	Dimension (mm)		
	IC	S	RE
09	5.56	2.38	0.2-0.4
11	6.35	3.18	0.2-0.8
16	9.52	4.76	0.2-1.2
22	12.7	4.76	0.4-3.0
27	15.88	6.35	0.8

Insert	Designation	ap (mm)	Feed (mm/rev)	Coating																								
				Cermet			CVD coated							PVD coated														
				PV3010	CT3000	TT3005	TT7005	TT7015	TT7025	TT8105B	TT8115B	TT8125B	TT8135B	TT9215	TT9225	TT9235	TT5100	TT7100	TT5080	TT8020	TT9080	TT3010	TT3020	TT9020	P20	K10		
 Finishing	TPGN 090204	0.5-3.0	0.07-0.20																							●	●	
	110304	0.7-3.0	0.07-0.20																								●	●
	110308	1.0-3.0	0.10-0.25											●														●
	160302	1.0-5.0	0.05-0.18																									●
	160304	1.0-5.0	0.07-0.20											●														●
	160308	1.0-5.0	0.10-0.25					●					●	●														●
	160312	1.0-5.0	0.15-0.30																									●
	220404	1.5-7.0	0.07-0.20																									●
	220408	1.5-7.0	0.10-0.25												●													●
	220412	1.5-7.0	0.15-0.30																									●
	220416	1.5-7.0	0.20-0.35																									●
	220425	1.5-7.0	0.25-0.40																									●
270608	3.0-8.0	0.15-0.25											●														●	
 Right hand Finishing	TPGT 090204 L-C	0.3-1.5	0.05-0.20			●																					●	
	110304 L-C	0.5-2.0	0.05-0.20			●																					●	
	110304 R-C	0.5-2.0	0.05-0.20			●																					●	
	110308 L-C	0.5-2.0	0.07-0.25			●																					●	
	160404 L-C	0.7-3.0	0.05-0.20			●																					●	
	160404 R-C	0.7-3.0	0.05-0.20			●																					●	
 Left hand Finishing	TPGX 090202 L	0.4-1.5	0.05-0.15			●																					●	
	090204 L	0.6-1.5	0.08-0.20			●																					●	
	110302 L	0.5-1.5	0.08-0.20			●																					●	
	110302 R	0.5-1.5	0.08-0.20			●																					●	
	110304 L	0.6-2.0	0.08-0.20			●																					●	
	110304 R	0.6-2.0	0.08-0.20			●																					●	

A49, A50, A82,
A167, A183, A184

● Standard items



Positive 11° clearance triangular inserts

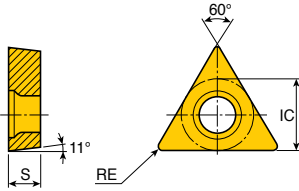

Size	Dimension (mm)		
	IC	S	RE
09	5.56	2.38	0.2-0.8
11	6.35	2.38-3.18	0.2-0.8
16	9.52	3.18-3.97	0.2-1.2
22	12.7	4.76	0.4-1.2

Insert	Designation	ap (mm)	Feed (mm/rev)	Cermat		CVD coated								PVD coated											
				PV3010	CT3000	TT3005	TT7005	TT7015	TT7025	TT8105B	TT8115B	TT8125B	TT8135B	TT9215	TT9225	TT9235	TT15100	TT17100	TT15080	TT18020	TT19080	TT13010	TT13020	TT19020	K10
 Type B Medium	TPMR 090204 ✓	0.5-2.0	0.10-0.25							●	●				●										
	090208 ✓	0.7-2.0	0.13-0.30					●		●	●				●										
	110304 ✓	0.7-3.0	0.10-0.25	●		●	●			●	●				●			●							
	110308	1.0-3.0	0.13-0.30	●	●					●	●				●										
	160304 ✓	1.0-5.0	0.10-0.25	●	●					●	●	●			●			●	●						
	160308	1.0-5.0	0.13-0.30	●		●	●			●	●				●			●	●						
	160312	1.0-5.0	0.15-0.35							●	●														
	220404 ✓	1.0-7.0	0.10-0.25								●	●				●									
220408 ✓	1.5-7.0	0.13-0.30				●				●	●				●										
220412 ✓	1.5-7.0	0.15-0.35								●	●														
 Finishing	TPMT 090202 FA	0.1-1.2	0.03-0.15	●	●					●	●				●			●	●						
	090204 FA	0.2-1.2	0.05-0.20	●	●					●	●							●	●						
	110302 FA	0.1-1.5	0.03-0.15	●	●					●	●							●	●						
	110304 FA	0.2-1.5	0.05-0.20	●	●					●	●							●	●						
	110308 FA	0.3-1.5	0.08-0.25	●	●					●	●							●	●						
	16T304 FA	0.2-2.0	0.05-0.20	●	●					●	●							●	●						
16T308 FA	0.3-2.0	0.08-0.25	●	●					●	●							●	●							
 Finishing	TPMT 110304 FG	0.4-1.5	0.07-0.20	●	●	●				●	●				●			●							
 Medium	TPMT 090202 FM	0.5-1.5	0.07-0.20							●	●				●			●	●						
	090204 FM	0.5-1.5	0.08-0.20							●	●				●			●	●						
	110302 FM	0.5-1.5	0.07-0.20							●	●							●	●						
	110304 FM	0.5-1.5	0.08-0.20							●	●							●	●						
	110308 FM	0.8-1.5	0.10-0.20							●	●							●	●						
	160302 FM	0.5-2.0	0.07-0.20							●	●							●	●						
	160304 FM	0.5-2.0	0.08-0.20							●	●							●	●						
160308 FM	0.8-2.5	0.10-0.25							●	●							●	●							
 Medium	TPMT 090204 PC	0.3-2.0	0.06-0.18							●	●	●			●			●							
	110204 PC	0.4-2.5	0.06-0.20								●	●	●				●		●						
	110208 PC	0.5-2.5	0.10-0.26									●	●	●				●		●					
	110304 PC	0.4-2.5	0.06-0.20									●	●	●				●		●					
	110308 PC	0.5-2.5	0.10-0.26									●	●	●				●		●					
	16T304 PC	0.45-3.0	0.08-0.25									●	●	●				●		●					
16T308 PC	0.5-3.0	0.10-0.30									●	●	●				●		●						



A49, A50, A82,
A167, A183, A184

▶ ✓: Type B chip breaker

●: Standard items





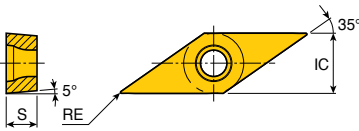

VBET VBGT



Positive 5° clearance 35° rhombic inserts



Size	Dimension (mm)		
	IC	S	RE
11	6.35	3.18	0.03-0.4
16	9.52	4.76	0.1-0.4

Insert	Designation	ap (mm)	Feed (mm/rev)	Cermet								PVD coated		Uncoated		
				PV3010	CT3000	TT5080	TT8020	TT9080	TT3010	TT3020	TT9020	TT4410	TT4430	P20	K10	
 Right hand Finishing	VBET 110301 L-GF	0.2-1.5	0.02-0.15													
	110301 R-GF	0.2-1.5	0.02-0.15										●			
	110302 L-GF	0.3-1.5	0.03-0.17											●		
	110302 R-GF	0.3-1.5	0.03-0.17												●	
	110304 L-GF	0.3-1.5	0.05-0.20												●	
	110304 R-GF	0.3-1.5	0.05-0.20												●	
 Right hand Finishing	VBET 1103003 L-GW *	0.1-1.5	0.02-0.15													●
	1103003 R-GW *	0.1-1.5	0.02-0.15													●
 Left hand Finishing	VBGT 1103003 L-FF	0.05-0.4	0.03-0.10													●
	1103003 R-FF	0.05-0.4	0.03-0.10													●
	110301 L-FF	0.1-0.5	0.03-0.12													●
	110301 R-FF	0.1-0.5	0.03-0.12													●
	110302 L-FF	0.1-0.5	0.03-0.15													●
	110302 R-FF	0.1-0.5	0.03-0.15													●
 Finishing	VBGT 110301 SA	0.1-1.5	0.01-0.20					●								●
	110302 SA	0.2-1.5	0.02-0.20					●								●
	110304 SA	0.2-1.5	0.05-0.20					●								●
	160401 SA	0.1-1.5	0.01-0.20					●								●
	160402 SA	0.2-1.5	0.02-0.20					●								●
	160404 SA	0.2-2.5	0.03-0.20					●								●
 Finishing For Swiss	VBGT 110302M SL-F	0.02-0.25	0.02-0.10												●	●
 Medium For Swiss	VBGT 110301M SM-F	0.2-1.5	0.02-0.12												●	●
	110302M SM-F	0.2-1.5	0.02-0.12												●	●
	110304M SM-F	0.2-1.5	0.03-0.12												●	●



A84, A85, A88-A90, A96, A98, A99, A138, A153, A187, A189, A191, A192, A211

- ▶ *: Wiper inserts should be applied to □VJBR/L...
- ▶ M: Corner radius minus tolerance
- ▶ - F: Sharp edge

●: Standard items

VBGT VBMT VBMX



Positive 5° clearance 35° rhombic inserts

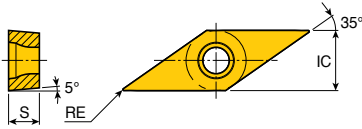

Size	Dimension (mm)		
	IC	S	RE
11	6.35	3.18	0.4-0.8
16	9.52	4.76	0.2-1.2

Insert	Designation	ap (mm)	Feed (mm/rev)	Cermat		CVD coated										PVD coated											
				PV3010	CT3000	TT3005	TT7005	TT7015	TT7025	TT8105B	TT8115B	TT8125B	TT8135B	TT9215	TT9225	TT9235	TT15100	TT17100	TT15080	TT8020	TT9080	TT3010	TT3020	TT9020	K10		
Finishing	VBGT 160404 FGS	0.2-2.5	0.03-0.20		●																						
	160408 FGS	0.3-2.5	0.05-0.20		●																						
	160412 FGS	0.3-2.5	0.07-0.20		●																						
Finishing	VBMT 110304 FA	0.2-1.5	0.05-0.20	●	●																						
	160404 FA	0.2-2.0	0.05-0.20	●	●																						
	160408 FA	0.3-2.0	0.08-0.25	●	●																						
Finishing	VBMT 160404 FG	0.5-1.5	0.07-0.20	●	●	●	●																				
	160408 FG	0.7-2.0	0.10-0.25	●	●	●	●	●																			
Medium	VBMT 110304 FM	0.5-1.5	0.08-0.20																								
	110308 FM	0.5-1.5	0.10-0.20																								
	160404 FM	0.5-2.0	0.08-0.20																								
	160408 FM	0.8-2.0	0.10-0.20																								
	160412 FM	1.0-2.5	0.10-0.25																								
Finishing	VBMT 160404 FX	0.2-2.0	0.05-0.20	●	●																						
	160408 FX	0.2-2.0	0.07-0.20	●	●																						
Medium	VBMT 160404 MT	0.6-3.0	0.10-0.25	●	●		●	●																			
	160408 MT	0.9-3.0	0.13-0.30	●	●		●	●																			
	160412 MT	1.2-3.0	0.15-0.30																								
Medium	VBMT 160404 PC	0.5-2.8	0.07-0.22																								
	160408 PC	0.5-2.8	0.10-0.27																								
	160412 PC	0.5-2.8	0.10-0.28																								
Finishing	VBMX 160402 FG	0.3-1.5	0.05-0.20		●																						
	160404 FG	0.5-1.5	0.07-0.20		●																						
	160408 FG	0.7-2.0	0.10-0.25		●																						

A84, A85, A88-A90, A92, A93,
A96, A98, A99, A138, A153,
A187, A189, A191, A192, A211

● Standard items



Positive 7° clearance 35° rhombic inserts

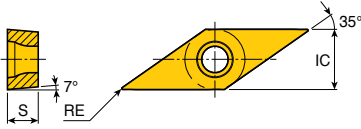

Size	Dimension (mm)		
	IC	S	RE
11	6.35	3.18	0.08-0.4
16	9.52	4.76	0.2-1.2
22	12.7	5.56	3.0

Insert	Designation	ap (mm)	Feed (mm/rev)	Cermet		PVD coated								Uncoated		
				PV3010	CT3000	TT5080	TT8020	TT9080	TT3010	TT3020	TT9020	TT4410	TT4430	P20	K10	
<p>Medium For aluminum</p>	VCGT 110302 FL	0.2-2.5	0.05-0.20													●
	110304 FL	0.5-3.0	0.05-0.25													●
	160402 FL	0.5-2.5	0.05-0.25													●
	160404 FL	0.5-3.0	0.05-0.25													●
	160408 FL	0.5-3.0	0.10-0.25													●
	160412 FL	0.5-3.0	0.10-0.25													●
	220530 FL	1.5-4.5	0.15-0.30													●
<p>Roughing For Swiss</p>	VCGT 1103008 SH-F	0.5-2.5	0.05-0.15								●					
	110301 SH-F	0.5-2.5	0.05-0.15								●					
	110302 SH-F	0.5-2.5	0.05-0.15								●					
<p>Medium For Swiss</p>	VCGT 110301M SM-F	0.2-1.5	0.02-0.12									●	●			
	110302M SM-F	0.2-1.5	0.02-0.12									●	●			
	110304M SM-F	0.2-1.5	0.03-0.12									●	●			
<p>Finishing For Swiss</p>	VCGT 110301 SA	0.1-1.5	0.01-0.20				●				●					
	110302 SA	0.2-1.5	0.02-0.20				●				●					
	110304 SA	0.2-1.5	0.05-0.20				●				●					
<p>Finishing For Swiss</p>	VCGT 110302M SL-F	0.02-0.25	0.02-0.10									●	●			



A86, A87, A96, A139,
A189, A191, A192

▶ M: Corner radius minus tolerance
▶ - F: Sharp edge

●: Standard items

Positive 7° clearance 35° rhombic inserts

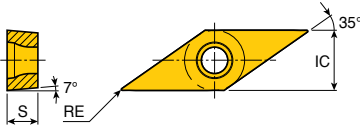

Size	Dimension (mm)		
	IC	S	RE
08	4.76	2.38	0.2-0.4
11	6.35	3.18	0.4
16	9.52	4.76	0.4-0.8

Insert	Designation	ap (mm)	Feed (mm/rev)	Coating																					
				Cermet		CVD coated							PVD coated												
				PV3010	CT3000	TT3005	TT7005	TT7015	TT7025	TT8105B	TT8115B	TT8125B	TT8135B	TT9215	TT9225	TT9235	TT5100	TT7100	TT5080	TT8020	TT9080	TT3010	TT3020	TT9020	K10
 VCMT 08, 11	VCMT 080202 PC	0.2-1.5	0.02-0.15										●		●										
	080204 PC	0.2-1.5	0.05-0.20										●	●		●									
	110304 PC	0.1-1.7	0.05-0.20										●	●		●							●		
	160404 PC	0.3-2.0	0.05-0.20										●	●		●							●		
	160408 PC	0.3-2.0	0.07-0.20										●	●		●							●		
 VCMT 16 Medium																									
 Medium	VCMT 080202 FM	0.5-1.5	0.07-0.15									●	●			●			●	●					
	080204 FM	0.5-1.5	0.08-0.15									●	●			●			●	●					
	110304 FM	0.5-1.5	0.08-0.20									●	●			●			●	●					
	160404 FM	0.5-2.0	0.08-0.20									●	●			●			●	●					
	160408 FM	0.8-2.0	0.10-0.20									●	●			●			●	●					

● Standard items



A86, A87, A90,
A139, A189, A191,
A192, A214

Positive 11° clearance 35° rhombic inserts

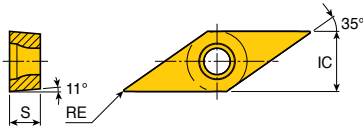

Size	Dimension (mm)		
	IC	S	RE
08	4.76	2.38	0.1-0.2
11	6.35	3.18	0.03-0.2

Insert	Designation	ap (mm)	Feed (mm/rev)	Cermet		PVD coated						Uncoated				
				PV3010	CT3000	TT5080	TT8020	TT9080	TT3010	TT3020	TT9020	TT4410	TT4430	P20	K10	
 Right hand Finishing	VPET 080201 L-GF	0.2-1.5	0.02-0.15													
	080201 R-GF	0.2-1.5	0.02-0.15								●					
	080202 L-GF	0.3-1.5	0.03-0.17								●					
	080202 R-GF	0.3-1.5	0.03-0.17								●					
	1103003 L-GF	0.2-1.5	0.02-0.12								●					
	1103003 R-GF	0.2-1.5	0.02-0.12								●					
	110301 L-GF	0.2-1.5	0.02-0.15								●					
	110301 R-GF	0.2-1.5	0.02-0.15								●					
	110302 L-GF	0.3-1.5	0.03-0.17								●					
	110302 R-GF	0.3-1.5	0.03-0.17								●					
 Left hand Finishing	VPGT 080201 L-FF	0.08-0.4	0.03-0.12								●					
	080201 R-FF	0.08-0.4	0.03-0.12								●					
	080202 L-FF	0.1-0.4	0.03-0.15								●					
	080202 R-FF	0.1-0.4	0.03-0.15								●					
	1103003 R-FF	0.05-0.4	0.03-0.10								●					
	110301 R-FF	0.1-0.5	0.03-0.12								●					
	110302 L-FF	0.1-0.5	0.03-0.15								●					
	110302 R-FF	0.1-0.5	0.03-0.15								●					

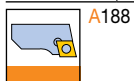

● Standard items

LNMM



Inserts

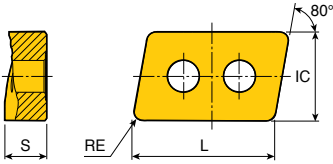

Size	Dimension (mm)			
	L	IC	S	RE
40	40.6	25.4	11.65	2.38

Insert	Designation	ap (mm)	Feed (mm/rev)	Coating																					
				Cermet		CVD coated							PVD coated												
				PV3010	CT3000	TT3005	TT7005	TT7015	TT7025	TT8105B	TT8115B	TT8125B	TT8135B	TT9215	TT9225	TT9235	TT5100	TT7100	TT5080	TT8020	TT9080	TT3010	TT3020	TT9020	K10
	LNMM 401224 R-HX	6.0-32.0	0.70-1.50								●	●	●					●							
	401224 L-HX	6.0-32.0	0.70-1.50									●						●							
Roughing																									



●: Standard items



LNMX

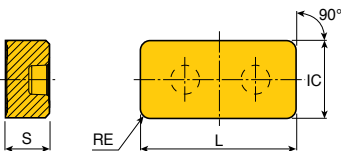

Inserts



Size	Dimension (mm)			
	L	IC	S	RE
50	50.8	25.4	14.2	3.2

Insert	Designation	ap (mm)	Feed (mm/rev)	Coating																					
				Cermet		CVD coated							PVD coated												
				PV3010	CT3000	TT3005	TT7005	TT7015	TT7025	TT8105B	TT8115B	TT8125B	TT8135B	TT9215	TT9225	TT9235	TT5100	TT7100	TT5080	TT8020	TT9080	TT3010	TT3020	TT9020	K10
	LNMX 501432 HD	6.0-40.0	0.70-1.60									●	●					●							
Roughing																									
	LNMX 501432 HY	5.0-40.0	0.65-1.50									●		●				●							
Roughing																									



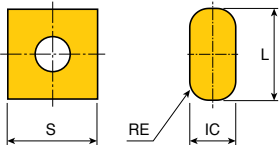

●: Standard items

TOP-RAIL inserts



Size	Dimension (mm)			
	L	IC	S	RE
19	19.05	10	19.05	4.0
30	30	12	19.05	4.0

Insert	Designation	ap (mm)	Feed (mm/rev)	Coating																						
				Cermet			CVD coated							PVD coated												
				PV3010	CT3000	TT3005	TT7005	TT7015	TT7025	TT8105B	TT8115B	TT8125B	TT8135B	TT9215	TT9235	TT5100	TT7100	TT5080	TT8020	TT9080	TT3010	TT3020	TT9020	K10		
 Finishing	LNMX 191940 TWF	0.3-5.0	0.30-1.0							•	•	•														
 Medium	LNMX 191940 TWM	1.5-9.0	0.45-1.5							•	•	•														
	301940 TWM	1.5-15.0	0.50-1.5							•	•	•														
 Roughing	LNMX 301940 TWR	2.0-15.0	0.70-1.8							•	•	•														



• Standard items

Hard Turning for Ceramic Inserts



Selection guide for ceramic grades

For cast iron

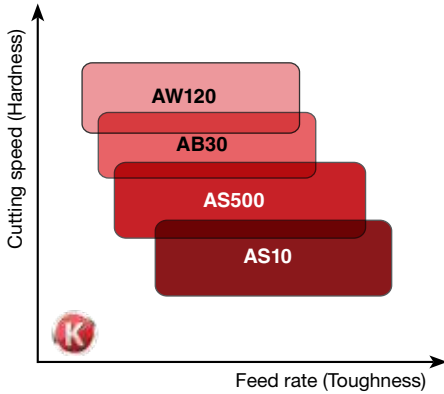

For hardened steel (HRc 40~60)

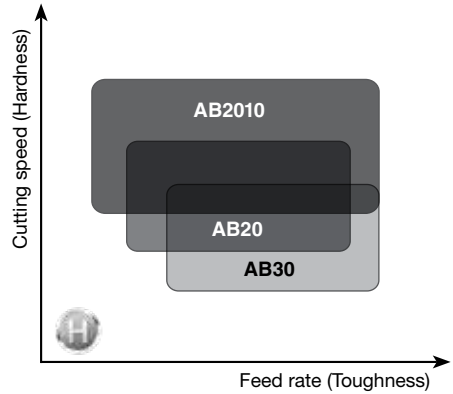

For super alloys

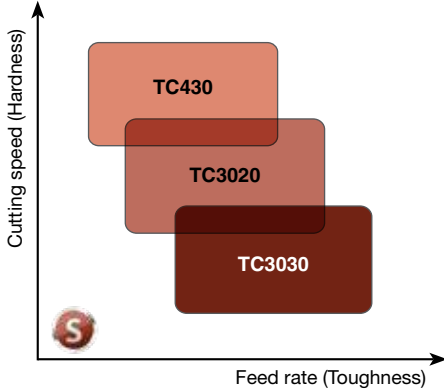

Information of Ceramic type

CE	Pressed type
CH	Dimple type
WZ	Wiper geometry

Edge preparations for ceramic inserts

Single land		Double land			
Symbol	Width(mm) X angle	Symbol	Width(mm) X angle		Shape
			L1 X A1	L2 X A2	
T2	0.10 X 30°	U1	0.7 X 15°	0.15 X 30°	<p>The diagram shows a cross-section of a ceramic insert edge. It features a double-land profile with dimensions L1 and L2. The first land has a width of L1 and a height of A1. The second land has a width of L2 and a height of A2. A 'hone' is applied to the top edge of the second land.</p>
T3	0.15 X 30°	U2	1.5 X 15°	0.15~0.2 X 30°	
T4	0.20 X 30°	U3	2.0 X 15°	0.2 X 30°	
T5	0.30 X 20°	- All items are honed			
T6	0.10 X 20°				
T7	0.20 X 20°				

▶ Edge preparations of non symbol items is 0.2 X 25° with no hone except □NMG-CE 0.25 X 20° with hone

Hard Turning for CBN and PCD Inserts



Selection guide for CBN and PCD grades

For hardened steel (HRC ≥ 50, CBN)

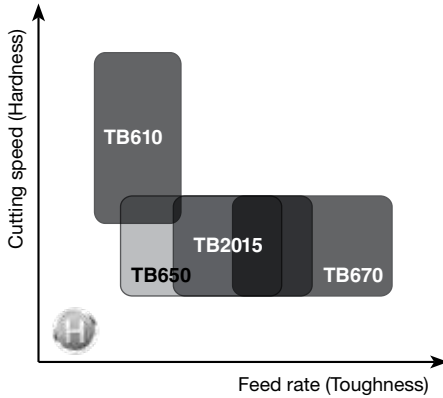

For cast iron (CBN)

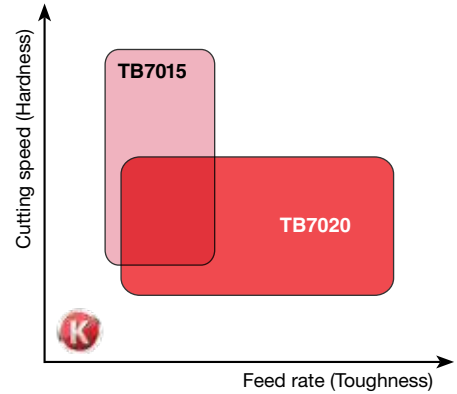

▶ TB730 for General turning of sintered or powder metals

For non-ferrous material (PCD)

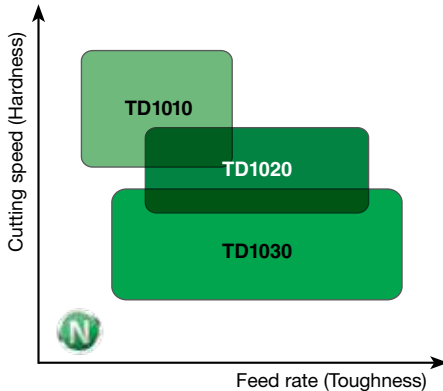

Information of CBN/PCD type

CBN	LS	Brazed small size CBN Tip, 1 corner
	LS2	Brazed small size CBN Tip, 2 corners
	LN	Brazed large size CBN Tip, 1 corner
	LN2	Brazed large size CBN Tip, 2 corners
	SD	Solid type
	FT	Full Top type
	DA	Dimple type
PCD	WZ	Wiper geometry
	LN-7	Rake angle 7°
	LN-10	Rake angle 10°
	CB	Chip breaker - Roughing medium
	CF	Chip breaker - Finishing

Edge preparations for CBN inserts

Single land				
Symbol	Width(mm) X angle L X A	Symbol	Width(mm) X angle L X A	Shape
TL	0.13X15°	SL	0.13X15°+ honed	
TM	0.13X25°	SM	0.13X25°+ honed	
TH	0.13X35°	SH	0.13X35°+ honed	

▶ Edge preparations of non symbol items depends on grades

TB610, TB2015, TB650, TB670: 0.13x20°+honed

TB730, TB7015 : 0.13x20°+no honed

TB7020 : 0.20x20°+honed

Negative 80° rhombic inserts

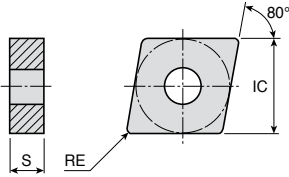

Size	Dimension (mm)		
	IC	S	RE
12	12.7	4.76	0.4-1.6
16	15.88	4.76-6.35	0.8-1.6
19	19.05	6.35-7.94	0.8-1.2

Insert	Designation	ap (mm)	Feed (mm/rev)	Ceramic																
				AB2010	AB20	AB30	AW120	AS500	SC10	AS10	TC430	TC3020	TC3030							
	CNGA 120404	0.1-3.0	0.05-0.15	●	●	●														
	120404 T2	0.1-3.0	0.05-0.15			●														
	120404 T7	0.1-3.0	0.05-0.15					●												
	120404 T7-WZ	0.1-3.0	0.05-0.15	●					●											
	120408	0.1-3.0	0.05-0.20	●	●	●		●	●	●										
	120408 E	0.1-3.0	0.05-0.20										●	●	●					
	120408 S7	0.1-3.0	0.05-0.20	●																
	120408 T2	0.1-3.0	0.05-0.20		●	●														
	120408 T6	0.1-3.0	0.05-0.20		●								●	●	●					
	120408 T6-WZ	0.1-3.0	0.05-0.20									●								
	120408 T7	0.1-3.0	0.05-0.20					●	●											
	120408 T7-WZ	0.1-3.0	0.05-0.20		●	●														
	120412	0.1-3.0	0.05-0.25		●	●	●				●	●								
	120412 T2	0.1-3.0	0.05-0.25			●														
	120412 T6-WZ	0.1-3.0	0.05-0.25								●									
	120412 T7	0.1-3.0	0.05-0.25						●											
	120412 T7-WZ	0.1-3.0	0.05-0.25		●	●														
	120416	0.1-3.0	0.05-0.30			●	●				●	●								
	160608	0.1-3.5	0.05-0.20			●														
	160612	0.1-3.5	0.05-0.25				●													
160616	0.1-3.5	0.05-0.30				●														
190608	0.1-4.5	0.05-0.20				●														
190612	0.1-4.5	0.05-0.25				●														
	CNGN 120404	0.1-3.0	0.05-0.15			●														
	120404 T6	0.1-3.0	0.05-0.15										●							
	120408	0.1-3.0	0.05-0.20	●	●	●					●									
	120408 E	0.1-3.0	0.05-0.20										●	●	●					
	120408 T6	0.1-3.0	0.05-0.20										●							
	120408 T7	0.1-3.0	0.05-0.20						●											
	120412 E	0.1-3.0	0.05-0.25										●	●	●					
	120412 T6	0.1-3.0	0.05-0.25										●							
	120412 T7	0.1-3.0	0.05-0.25					●												
	120416	0.1-3.0	0.05-0.30									●								
	120416 T6	0.1-3.0	0.05-0.30										●							

A58-A59 A119,
 A126, A146, A170,
 A194, A203, A205

●: Standard items

CNGN CNGX-CH CNMG-CE



Negative 80° rhombic inserts

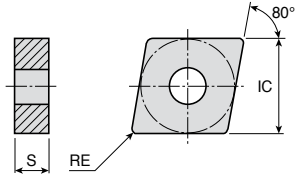

Size	Dimension (mm)		
	IC	S	RE
12	12.7	4.76-7.94	0.4-1.6

Insert	Designation	ap (mm)	Feed (mm/rev)	Ceramic												
				AB2010	AB20	AB30	AW120	SC500	AS500	SC10	AS10	TC430	TC3020	TC3030		
	CNGN 120708	0.1-3.0	0.05-0.20	●	●	●										
	120708 E	0.1-3.0	0.05-0.20										●	●	●	
	120708 T6	0.1-3.0	0.05-0.20										●	●	●	
	120712	0.1-3.0	0.05-0.25			●					●					
	120712 E	0.1-3.0	0.05-0.25										●	●	●	
	120712 T6	0.1-3.0	0.05-0.25										●	●	●	
	120712 T7	0.1-3.0	0.05-0.25				●									
	120716	0.1-3.0	0.05-0.30			●				●						
	120716 T6	0.1-3.0	0.05-0.30										●	●	●	
	120716 T7	0.1-3.0	0.05-0.30				●									
 Dimple type	CNGX 120712 CH	0.1-3.5	0.05-0.30									●				
	120712 T7-CH	0.1-3.5	0.05-0.30					●	●			●				
	120716 CH	0.1-3.5	0.05-0.35							●		●				
	120716 T7-CH	0.1-3.5	0.05-0.35							●						
 Pressed type	CNMG 120404 CE	0.1-3.0	0.05-0.15			●										
	120408 CE	0.1-3.0	0.05-0.20		●	●										

A58-A59, A119, A120,
A121, A126, A146, A170,
A194, A201, A203, A205

● Standard items

DNGA DNGN DNGX-CH DNMG-CE



Negative 55° rhombic inserts

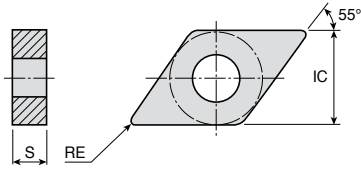

Size	Dimension (mm)		
	IC	S	RE
12	10	8.0	1.2
15	12.7	4.76-8.0	0.4-1.6

Insert	Designation	ap (mm)	Feed (mm/rev)	Ceramic											
				AB2010	AB20	AB30	AW120	AS500	SC10	AS10	TC430	TC3020	TC3030		
	DNGA 150404	0.1-2.5	0.05-0.15		●	●									
	150408	0.1-2.5	0.05-0.20	●	●	●									
	150412	0.1-2.5	0.05-0.25	●	●	●									
	150604	0.1-2.5	0.05-0.15	●	●	●									
	150608	0.1-2.5	0.05-0.20	●	●	●				●					
	150612	0.1-2.5	0.05-0.25	●	●	●				●					
	150616	0.1-2.5	0.05-0.30		●	●									
	DNGN 150408	0.1-2.5	0.05-0.20		●										
	150704	0.1-2.5	0.05-0.15			●									
	150708	0.1-2.5	0.05-0.20			●									
	150708 T6	0.1-2.5	0.05-0.20										●		
	150708 T7	0.1-2.5	0.05-0.20				●								
	150712 T6	0.1-2.5	0.05-0.25											●	
	150712 T7	0.1-2.5	0.05-0.25				●								
 Dimple type	DNGX 120712 T7-CH	0.1-3.0	0.05-0.30											●	
	150708 T7-CH	0.1-3.0	0.05-0.25											●	
	150712 CH	0.1-3.0	0.05-0.30							●				●	
	150712 T7-CH	0.1-3.0	0.05-0.30						●					●	
	150716 CH	0.1-3.5	0.05-0.35											●	
	150716 T7-CH	0.1-3.5	0.05-0.35											●	
 Pressed type	DNMG 150608 CE	0.1-2.5	0.05-0.20			●									

A52, A53, A60, A61, A122, A127, A146, A171, A195, A203, A206, A215

●: Standard items

Negative 75° rhombic inserts

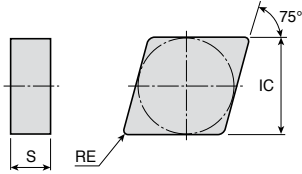

Size	Dimension (mm)		
	IC	S	RE
13	12.7	7.94	0.8-1.6

Insert	Designation	ap (mm)	Feed (mm/rev)	Ceramic										
				AB2010	AB20	AB30	AW120	AS500	SC10	AS10	TC430	TC3020	TC3030	
	ENGN 130708	0.1-2.5	0.05-0.20	●	●	●								
	130712 T5	0.1-2.5	0.05-0.25			●								
	130716	0.1-2.5	0.05-0.30		●									
	130716 U2	0.1-2.5	0.05-0.30			●								



A128

● Standard items

HNGX-CH

Negative 120° hexagonal inserts

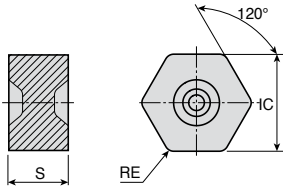

Size	Dimension (mm)		
	IC	S	RE
05	12.7	7.94	1.2-1.6

Insert	Designation	ap (mm)	Feed (mm/rev)	Ceramic										
				AB2010	AB20	AB30	AW120	AS500	SC10	AS10	TC430	TC3020	TC3030	
	HNGX 050712 CH	0.05-0.25	0.10-2.00							●				
	050712 T7-CH	0.05-0.25	0.10-2.00					●						
	050716 CH	0.05-0.3	0.10-2.00							●				

Dimple type

Negative square inserts

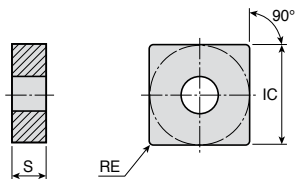

Size	Dimension (mm)		
	IC	S	RE
12	12.7	4.76-7.94	0.4-1.6
15	15.88	7.94	1.6
19	19.05	6.35-7.94	0.8-1.6

Insert	Designation	ap (mm)	Feed (mm/rev)	Ceramic											
				AB2010	AB20	AB30	AW120	AS500	SC10	AS10	TC430	TC3020	TC3030		
	SNGA 120404	0.1-3.0	0.05-0.15	●	●	●									
	120408	0.1-3.0	0.05-0.20	●	●	●									
	120408 S7	0.1-3.0	0.05-0.20	●											
	120412	0.1-3.0	0.05-0.25	●	●	●				●					
	120416	0.1-3.0	0.05-0.30						●	●					
	190608	0.1-4.5	0.05-0.20			●									
	190612	0.1-4.5	0.05-0.25			●									
	SNGN 120404	0.1-3.0	0.05-0.15	●	●	●									
	120404 T7	0.1-3.0	0.05-0.15				●								
	120408	0.1-3.0	0.05-0.20	●	●	●				●					
	120408 T6	0.1-3.0	0.05-0.20								●	●	●		
	120412	0.1-3.0	0.05-0.25	●	●	●				●					
	120412 T6	0.1-3.0	0.05-0.25											●	
	120412 T7	0.1-3.0	0.05-0.25				●								
	120416	0.1-3.0	0.05-0.30	●	●	●				●					
	120416 T6	0.1-3.0	0.05-0.30								●				
	120416 T7	0.1-3.0	0.05-0.30				●								
	120708	0.1-3.0	0.05-0.20	●	●	●									
	120708 T6	0.1-3.0	0.05-0.20								●				
	120708 T7	0.1-3.0	0.05-0.20				●								
	120712	0.1-3.0	0.05-0.25	●	●	●				●					
	120712 T6	0.1-3.0	0.05-0.25									●	●	●	
	120712 T7	0.1-3.0	0.05-0.25				●								
	120716	0.1-3.0	0.05-0.30	●		●									
	120716 T7	0.1-3.0	0.05-0.30				●								
	150716	0.1-3.5	0.05-0.30			●									
	190716	0.1-4.0	0.05-0.30			●									

● Standard items



A65, A66, A104,
A105, A130, A131,
A172, A197



SNGX-CH SNMG-CE

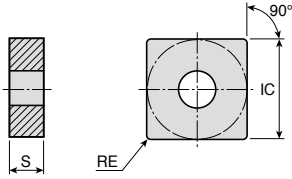

Negative square inserts



Size	Dimension (mm)		
	IC	S	RE
12	12.7	4.76-7.94	0.8-1.6
15	15.8 8	7.94	1.6

Insert	Designation	ap (mm)	Feed (mm/rev)	Ceramic										
				AB2010	AB20	AB30	AW120	SC500	AS500	SC10	AS10	TC430	TC3020	TC3030
 Dimple type	SNGX 120712 CH	0.1-3.0	0.05-0.30							●	●			
	120716 CH	0.1-3.0	0.05-0.35							●	●			
	120716 T7-CH	0.1-3.0	0.05-0.35					●	●		●			
	150716 T7-CH	0.1-3.5	0.05-0.35								●			
 Pressed type	SNMG 120408 CE	0.1-3.0	0.05-0.20			●								



 A65, A66, A104,
 A105, A123,
 A172, A197

● Standard items

TNGA TNGN TNMG-CE

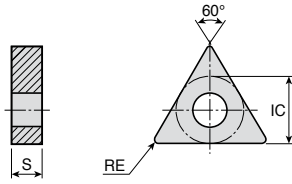

Negative triangular inserts



Size	Dimension (mm)		
	IC	S	RE
16	9.52	4.76	0.4-1.6
22	12.7	4.76	0.4-1.6

Insert	Designation	ap (mm)	Feed (mm/rev)	Ceramic											
				AB2010	AB20	AB30	AW120	AS500	SC10	AS10	TC430	TC3020	TC3030		
	TNGA 160404	0.1-2.5	0.05-0.15	●	●	●									
	160404 T2	0.1-2.5	0.05-0.15			●									
	160408	0.1-2.5	0.05-0.20	●	●	●									
	160408 T2	0.1-2.5	0.05-0.20			●									
	160412	0.1-2.5	0.05-0.25	●	●	●									
	160412 T2	0.1-2.5	0.05-0.25			●									
	160416	0.1-2.5	0.05-0.30		●										
	220404	0.1-3.0	0.05-0.15		●	●									
	220408	0.1-3.0	0.05-0.20	●	●	●									
	220412	0.1-3.0	0.05-0.25		●	●									
220416	0.1-3.0	0.05-0.30		●	●										
	TNGN 160404	0.1-2.5	0.05-0.15		●	●									
	160408	0.1-2.5	0.05-0.20	●	●	●					●				
	160408 T7	0.1-2.5	0.05-0.20				●								
	160412	0.1-2.5	0.05-0.25		●	●									
	160412 T7	0.1-2.5	0.05-0.25				●	●							
	160416 T7	0.1-1.0	0.05-0.20				●								
	TNMG 160408 CE	0.1-2.5	0.05-0.20			●									

Pressed type



A54, A67, A68, A106,
A114, A115, A148,
A173, A200, A204

●: Standard items



VNGA VNGX-CH

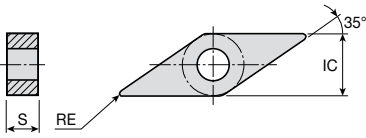

Negative 35° rhombic inserts



Size	Dimension (mm)		
	IC	S	RE
16	9.52	4.76-7.94	0.4-1.2
22	12.7	4.76	1.2

Insert	Designation	ap (mm)	Feed (mm/rev)	Ceramic										
				AB2010	AB20	AB30	AW120	AS500	SC10	AS10	TC430	TC3020	TC3030	
	VNGA 160404	0.05-1.0	0.05-0.10	●	●	●								
	160408	0.05-1.0	0.05-0.15	●	●	●								
	160412	0.05-1.5	0.05-0.20		●	●								
	220412	0.05-2.0	0.05-0.20			●								
 Dimple type	VNGX 160712 T7-CH	0.05-1.5	0.05-0.20							●				



A55, A56, A108,
A148, A206

● Standard items

WNGA



Negative 80° trigon inserts

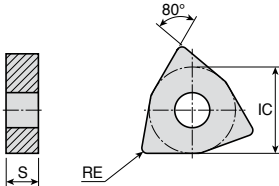

Size	Dimension (mm)		
	IC	S	RE
08	12.7	4.76	0.8-1.2

Insert	Designation	ap (mm)	Feed (mm/rev)	Ceramic										
				AB2010	AB20	AB30	AW120	AS500	SC10	AS10	TC430	TC3020	TC3030	
	WNGA 080408	0.1-2.5	0.05-0.25	●	●	●			●	●				
	080408 T7-WZ	0.1-2.5	0.05-0.25	●	●									
	080412	0.1-2.5	0.05-0.25	●	●	●			●	●				
	080412 T7	0.1-2.5	0.05-0.25					●						



A57, A69, A109,
A149, A169,
A198, A207

● Standard items

RCGX RPGN RPGX T11-



Positive round inserts

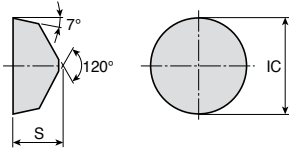

Size	Dimension (mm)		Size	Dimension (mm)	
	IC	S		IC	S
06	6.35	3.18-6.35	19	19.05	10.0
09	9.52	7.94	25	25.4	12.0
12	12.7	4.76-7.94	T11	31.9	19.05
15	15.88	8			

Insert	Designation	ap (mm)	Feed (mm/rev)	Ceramic										
				AB2010	AB20	AB30	AW120	AS500	SC10	AS10	TC430	TC3020	TC3030	
 	RCGX 060600 T6	0.1-2.0	0.05-0.25									●		
	060600 U1	0.1-2.0	0.05-0.25			●								
	090700 E	0.1-3.0	0.05-0.35										●	●
	090700 E04	0.1-3.0	0.05-0.30										●	●
	090700 T6	0.1-3.0	0.05-0.30									●	●	●
	090700 U1	0.1-3.0	0.05-0.30		●	●								
	120700	0.1-4.0	0.05-0.35			●								
	120700 E	0.1-4.0	0.05-0.35										●	●
	120700 E04	0.1-4.0	0.05-0.35										●	●
	120700 T6	0.1-4.0	0.05-0.35									●	●	●
	120700 U2	0.1-4.0	0.05-0.35		●	●								
	151000 U2	0.1-5.0	0.05-0.35		●	●								
	191000 U2	0.1-5.0	0.05-0.35		●	●								
	251200 U3 *	0.1-5.0	0.05-0.35			●								
 	RPGN 060300 E	0.1-2.0	0.05-0.25											●
	120400 E	0.1-4.0	0.05-0.35										●	●
	120400 T6	0.1-4.0	0.05-0.35									●	●	●
 	RPGX 090700 E	0.1-3.0	0.05-0.35										●	●
	090700 T6	0.1-3.0	0.05-0.35									●	●	●
	120700 E	0.1-4.0	0.05-0.35										●	●
	120700 T6	0.1-4.0	0.05-0.35									●	●	●
 	T11- 3219	0.1-5.0	0.05-0.35		●									

A116, A117, A118

▶ *: This is the only item with a 140° bottom

●: Standard items



Positive square inserts

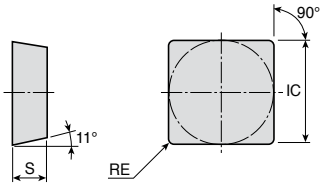

Size	Dimension (mm)		
	IC	S	RE
12	12.7	3.18-4.76	0.8-1.2

Insert	Designation	ap (mm)	Feed (mm/rev)	Ceramic											
				AB2010	AB20	AB30	AW120	AS500	SC10	AS10	TC430	TC3020	TC3030		
	SPGN 120308	0.1-3.5	0.05-0.20			●					●				
	120412	0.1-3.5	0.05-0.20								●				



A48, A166

● Standard items

TPGN

Positive triangular inserts

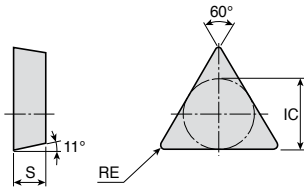

Size	Dimension (mm)		
	IC	S	RE
11	6.35	3.18	0.4-0.8
16	9.52	3.18	0.4-0.8
22	12.7	4.76	0.8

Insert	Designation	ap (mm)	Feed (mm/rev)	Ceramic										
				AB2010	AB20	AB30	AW120	AS500	SC10	AS10	TC430	TC3020	TC3030	
	TPGN 110304	0.1-2.0	0.05-0.10	●	●	●								
	110308	0.1-2.0	0.05-0.10	●	●	●								
	160304	0.1-2.5	0.05-0.15	●	●	●								
	160308	0.1-2.5	0.05-0.20	●	●	●								
	160308 T6	0.1-2.5	0.05-0.20									●		
	220408	0.1-3.0	0.05-0.20			●								



A49, A50, A167

● Standard items

CNGA CNGN-SD CNGX-DA



Negative 80° rhombic inserts

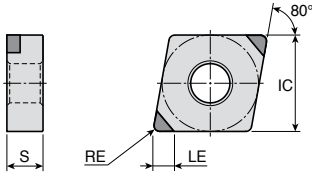

Size	Dimension (mm)		
	IC	S	RE
09	9.52	3.18	0.8
12	12.7	4.76	0.4-1.6

Insert	Designation	LE (mm)	ap (mm)	Feed (mm/rev)	CBN						PCD			
					TB610	TB650	TB670	TB730	TB7015	TB7020	TD1010	TD1020	TD1030	
	CNGA 120404 WZ-LS2	2.1	0.1-0.5	0.05-0.30	●	●	●							
	120408 WZ-LS2	2.1	0.1-0.5	0.05-0.30	●	●	●	●						
	120408 WZ-LS4	2.1	0.1-0.5	0.05-0.30	●	●	●							
	120412 WZ-LS2	2.5	0.1-0.5	0.05-0.30		●	●	●						
	120412 WZ-LS4	2.5	0.1-0.5	0.05-0.30			●							
	CNGA 120404 LN	4.2	0.1-0.5	0.05-0.30	●		●		●					
	120404 LS2	2.2	0.1-0.5	0.05-0.30	●	●	●	●	●					
	120404 LS4	2.2	0.1-0.5	0.05-0.30		●	●							
	120408 LN	4.0	0.1-0.5	0.05-0.30	●	●		●	●					
	120408 LN4	4.0	0.1-0.5	0.05-0.30		●								
	120408 LS2	2.1	0.1-0.5	0.05-0.30	●	●	●	●	●					
	120408 LS4	2.1	0.1-0.5	0.05-0.30		●	●	●	●					
	120412 LN	3.9	0.1-0.5	0.05-0.30	●		●		●					
	120412 LS2	2.5	0.1-0.5	0.05-0.30		●		●	●					
	120412 LS4	2.5	0.1-0.5	0.05-0.30			●	●						
	CNGA 120404 LN-10	4.0	0.1-3.0	0.05-0.25									●	
	120408 LN-10	3.9	0.1-3.0	0.05-0.25									●	
	120412 LN-10	3.8	0.1-3.0	0.05-0.25									●	
	CNGN 090308 SD	-	0.1-3.0	0.05-0.30						●				
	120412 SD	-	0.1-4.0	0.05-0.30						●				
	120416 SD	-	0.1-4.0	0.05-0.30						●				
	CNGX 120412 DA	-	0.1-4.0	0.05-0.30						●				
	120416 DA	-	0.1-4.0	0.05-0.30						●				



A58-A59, A119,
A126, A146, A170,
A194, A203, A205

●: Standard items

Negative 55° rhombic inserts

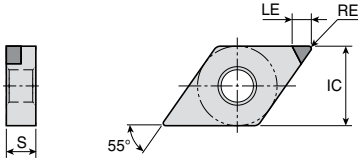

Size	Dimension (mm)		
	IC	S	RE
15	12.7	4.76-6.35	0.4-1.2

Insert	Designation	LE (mm)	ap (mm)	Feed (mm/rev)	CBN						PCD			
					TB610	TB650	TB670	TB730	TB7015	TB7020	TD1010	TD1020	TD1030	
	DNGA 150404 LN	4.2	0.1-0.5	0.05-0.30	●	●	●							
	150404 LS2	2.6	0.1-0.5	0.05-0.30	●	●	●							
	150404 LS4	2.6	0.1-0.5	0.05-0.30	●	●								
	150408 LN	3.9	0.1-0.5	0.05-0.30	●	●	●		●					
	150408 LS2	2.3	0.1-0.5	0.05-0.30	●	●	●	●						
	150408 LS4	2.3	0.1-0.5	0.05-0.30			●							
	150412 LN	3.5	0.1-0.5	0.05-0.30		●			●					
	150412 LS2	2.2	0.1-0.5	0.05-0.30			●	●						
	150412 LS4	2.2	0.1-0.5	0.05-0.30			●							
	150604 LN	4.2	0.1-0.5	0.05-0.30		●	●	●	●					
	150604 LS2	2.6	0.1-0.5	0.05-0.30	●	●	●	●						
	150608 LN	3.9	0.1-0.5	0.05-0.30	●	●	●	●						
	150608 LS2	2.3	0.1-0.5	0.05-0.30	●	●	●	●	●					
	150608 LS4	2.3	0.1-0.5	0.05-0.30			●							
150612 LS2	2.2	0.1-0.5	0.05-0.30			●								
	DNGA 150404 LN-10	4.0	0.1-2.5	0.05-0.20									●	
	150408 LN-10	3.7	0.1-2.5	0.05-0.20									●	
	150604 LN-10	4.0	0.1-2.5	0.05-0.20									●	
	150608 LN-10	3.7	0.1-2.5	0.05-0.20									●	

● Standard items

A52, A53, A60, A61,
 A146, A171, A195,
 A203, A206

SNGA SNGN-SD SNGX-DA



Negative square inserts

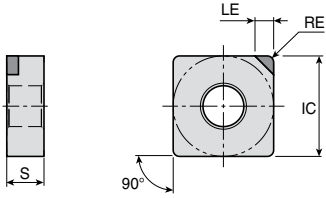

Size	Dimension (mm)		
	IC	S	RE
09	9.52	3.18	1.2
12	12.7	4.76	0.4-1.6

Insert	Designation	LE (mm)	ap (mm)	Feed (mm/rev)	CBN						PCD			
					TB610	TB650	TB670	TB730	TB7015	TB7020	TD1010	TD1020	TD1030	
	SNGA 120404 LS2	2.5	0.1-0.5	0.05-0.30			●	●						
	120408 LN	4.2	0.1-0.5	0.05-0.30		●			●					
	120408 LS2	2.5	0.1-0.5	0.05-0.30			●		●					
	120408 LS4	2.5	0.1-0.5	0.05-0.30			●							
	120408 LS8	2.5	0.1-0.5	0.05-0.30			●							
 Solid CBN	SNGN 090312 SD	-	0.1-3.0	0.05-0.30						●				
	120416 SD	-	0.1-4.0	0.05-0.30						●				
 Dimple type	SNGX 120416 DA	-	0.1-4.0	0.05-0.30						●				



A65, A66, A104, A105,
 A125, A130, A131,
 A147, A172, A197

● Standard items

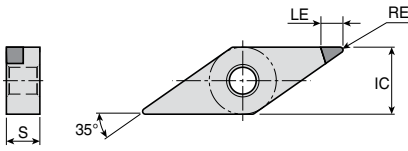
Negative 35° rhombic inserts



Size	Dimension (mm)		
	IC	S	RE
16	9.52	4.76	0.4-0.8

Insert	Designation	LE (mm)	ap (mm)	Feed (mm/rev)	CBN						PCD			
					TB610	TB650	TB670	TB730	TB7015	TB7020	TD1010	TD1020	TD1030	
	VNGA 160404 LN	5.0	0.1-0.5	0.05-0.30		●								
	160404 LS	3.2	0.1-0.5	0.05-0.30		●								
	160404 LS2	3.2	0.1-0.5	0.05-0.30			●	●						
	160408 LN	4.1	0.1-0.5	0.05-0.30		●								
	160408 LS2	2.4	0.1-0.5	0.05-0.30	●	●	●	●						
	160408 LS4	2.4	0.1-0.5	0.05-0.30					●					
 	VNGA 160404 LN-10	5.0	0.1-2.0	0.05-0.20									●	

 A55, A56, A108, A148, A206

● Standard items

CCGW CCGT-CB CCGT-CF



Positive 80° rhombic inserts

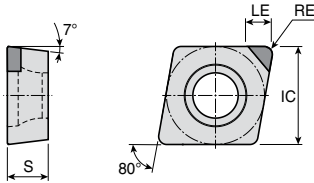

Size	Dimension (mm)		
	IC	S	RE
06	6.35	2.38	0.2-0.8
09	9.52	3.97	0.2-0.8
12	12.7	4.76	0.4-0.8

Insert	Designation	LE (mm)	ap (mm)	Feed (mm/rev)	CBN					PCD				
					TB610	TB650	TB670	TB730	TB7015	TB7020	TD1010	TD1020	TD1030	
	CCGW 060202 LS	2.4	0.05-0.5	0.05-0.30		●			●					
	060202 LS2	2.2	0.05-0.5	0.05-0.30			●	●						
	060204 LS	2.4	0.05-0.5	0.05-0.30		●			●					
	060204 LS2	2.1	0.05-0.5	0.05-0.30	●		●	●						
	060208 LS2	2.1	0.05-0.5	0.05-0.30	●		●	●						
	09T304 LS	2.4	0.05-0.5	0.05-0.30		●			●					
	09T304 LS2	2.4	0.05-0.5	0.05-0.30	●	●	●	●	●					
	09T304 WZ-LS	2.8	0.05-0.5	0.05-0.30		●								
	09T304 WZ-LS2	2.4	0.05-0.5	0.05-0.30			●	●						
	09T308 LS	2.3	0.05-0.5	0.05-0.30		●			●					
	09T308 LS2	2.3	0.05-0.5	0.05-0.30	●		●	●						
	09T308 WZ-LS	2.3	0.05-0.5	0.05-0.30		●								
	09T308 WZ-LS2	2.3	0.05-0.5	0.05-0.30		●		●						
	120404 LS2	2.1	0.05-0.5	0.05-0.30					●					
120408 LS	2.5	0.05-0.5	0.05-0.30						●					
120408 LS2	2.1	0.05-0.5	0.05-0.30				●							
	CCGW 060202 LN-7	3.1	0.08-3.0	0.05-0.30							●	●	●	
	060204 LN-7	3.1	0.08-3.0	0.05-0.30							●	●	●	
	09T304 LN-7	4.0	0.1-3.0	0.05-0.30							●	●	●	
	09T308 LN-7	3.9	0.1-3.0	0.05-0.30							●	●		
	120404 LN-7	4.0	0.1-3.0	0.05-0.30							●	●	●	
	120408 LN-7	3.9	0.1-3.0	0.05-0.30							●	●		
	CCGT 060204 CB	3.1	0.5-1.5	0.10-0.50								●		
	09T302 CB	4.15	0.5-2.0	0.10-0.50								●		
	09T304 CB	4.1	0.5-2.0	0.10-0.50								●		
	09T308 CB	4.0	0.5-2.0	0.10-0.50								●		
	120404 CB	4.1	0.5-2.0	0.10-0.50								●		
	120408 CB	4.0	0.5-2.0	0.10-0.50								●		
PCD chip breaker														
	CCGT 09T302 CF	4.15	0.1-1.0	0.05-0.20									●	
	09T304 CF	4.1	0.1-1.0	0.05-0.20									●	
	120404 CF	4.1	0.1-1.0	0.05-0.20									●	
	120408 CF	4.0	0.1-1.0	0.05-0.20									●	
PCD chip breaker														

● Standard items



A70-A72, A94,
A151, A174,
A175, A208

DCGW DCGT-CB DCGT-CF



Positive 55° rhombic inserts

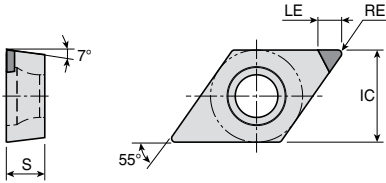

Size	Dimension (mm)		
	IC	S	RE
07	6.35	2.38	0.2-0.8
11	9.52	3.97	0.2-0.8

Insert	Designation	LE (mm)	ap (mm)	Feed (mm/rev)	CBN						PCD						
					TB610	TB650	TB670	TB730	TB7015	TB7020	TD1010	TD1020	TD1030				
	DCGW 070202 LS	2.6	0.05-0.5	0.05-0.30		●											
	070202 LS2	2.6	0.05-0.5	0.05-0.30	●		●	●									
	070204 LS	2.4	0.05-0.5	0.05-0.30		●				●							
	070204 LS2	2.4	0.05-0.5	0.05-0.30	●		●	●									
	070208 LS2	2.6	0.05-0.5	0.05-0.30					●								
	11T304 LS	2.6	0.05-0.5	0.05-0.30		●				●							
	11T304 LS2	3.4	0.05-0.5	0.05-0.30	●		●	●									
	11T308 LS	2.2	0.05-0.5	0.05-0.30		●				●							
	11T308 LS2	2.2	0.05-0.5	0.05-0.30	●		●	●									
	DCGW 070202 LN-7	3.4	0.1-2.0	0.05-0.30									●	●			
	070204 LN-7	3.3	0.1-2.0	0.05-0.30									●	●			
	11T302 LN-7	3.9	0.1-2.0	0.05-0.30									●	●	●		
	11T304 LN-7	3.7	0.1-2.0	0.05-0.30									●	●	●		
	11T308 LN-7	3.3	0.1-2.0	0.05-0.30									●	●	●		
	DCGT 070202 CB	3.4	0.5-1.5	0.10-0.50												●	
	070204 CB	3.3	0.5-1.5	0.10-0.50												●	
	11T302 CB	4.9	0.5-2.5	0.10-0.50												●	
	11T304 CB	4.7	0.5-2.5	0.10-0.50												●	
	11T308 CB	4.6	0.5-2.5	0.10-0.50												●	
	DCGT 070202 CF	3.4	0.1-1.0	0.05-0.20												●	
	070204 CF	3.3	0.1-1.0	0.05-0.20												●	
	11T302 CF	4.9	0.1-1.5	0.05-0.20												●	
	11T304 CF	4.7	0.1-1.5	0.05-0.20												●	
	11T308 CF	4.6	0.1-1.5	0.05-0.20												●	



A73-A76, A95, A97, A99,
A137, A141, A151,
A178-A180, A209, A214

●: Standard items

RCGX-FT



Positive round inserts

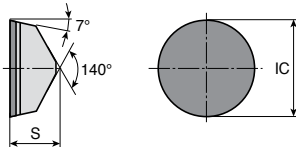

Size	Dimension (mm)	
	IC	S
06	6.35	3.18
09	9.52	3.18
12	12.7	4.76

Insert	Designation	LE (mm)	ap (mm)	Feed (mm/rev)	CBN					PCD			
					TB610	TB650	TB670	TB730	TB7015	TB7020	TD1010	TD1020	TD1030
 Full Top CBN	RCGX 060300 FT	-	0.1-1.0	0.05-0.30					●				
	090300 FT	-	0.1-1.5	0.05-0.30					●				
	120400 FT	-	0.1-1.5	0.05-0.30					●				



A116-A118

● Standard items

SCGW



Positive square inserts

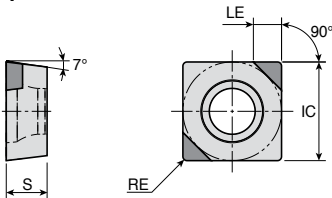

Size	Dimension (mm)		
	IC	S	RE
09	9.52	3.18-3.97	0.4-0.8

Insert	Designation	LE (mm)	ap (mm)	Feed (mm/rev)	CBN					PCD		
					TB610	TB650	TB670	TB730	TB7015	TB7020	TD1010	TD1020
	SCGW 09T304 LS2	2.7	0.05-0.5	0.05-0.30					●			
	09T308 LS2	2.7	0.05-0.5	0.05-0.30					●			



A80, A181

● Standard items

Positive triangular inserts

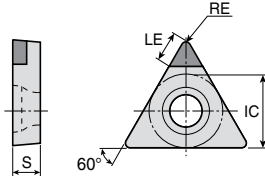

Size	Dimension (mm)		
	IC	S	RE
08	4.76	2.38	0.4
09	5.56	2.38	0.4-0.8
11	6.35	2.38-3.18	0.2-0.8
16	9.52	3.18-4.76	0.4-0.8

Insert	Designation	LE (mm)	ap (mm)	Feed (mm/rev)	CBN						PCD				
					TB610	TB650	TB670	TB730	TB7015	TB7020	TD1010	TD1020	TD1030		
	TCGW 090204 LS3	2.3	0.05-0.5	0.05-0.30			●	●							
	110204 LS	2.3	0.05-0.5	0.05-0.30		●			●						
	110204 LS3	2.3	0.05-0.5	0.05-0.30	●		●	●							
	110208 LS	2.1	0.05-0.5	0.05-0.30		●			●						
	110208 LS3	2.1	0.05-0.5	0.05-0.30			●	●							
	16T304 LS	2.8	0.05-0.5	0.05-0.30		●			●						
	16T304 LS3	2.8	0.05-0.5	0.05-0.30			●	●							
	16T308 LS	2.5	0.05-0.5	0.05-0.30		●			●						
	16T308 LS3	2.5	0.05-0.5	0.05-0.30	●		●	●							
	TPGN 090204 LS3	2.3	0.05-0.5	0.05-0.30	●										
	110302 LS3	2.8	0.05-0.5	0.05-0.30					●						
	110304 LS	2.6	0.05-0.5	0.05-0.30		●				●					
	110304 LS3	2.6	0.05-0.5	0.05-0.30					●						
	110308 LS3	2.3	0.05-0.5	0.05-0.30	●		●								
	160304 LS	2.8	0.05-0.5	0.05-0.30		●									
	160304 LS3	2.8	0.05-0.5	0.05-0.30	●		●								
	160308 LS	2.5	0.05-0.5	0.05-0.30		●									
	160308 LS3	2.5	0.05-0.5	0.05-0.30	●		●	●							
	TPGW 080204 LS3	2.1	0.05-0.5	0.05-0.30				●							
	090204 LS3	2.3	0.05-0.5	0.05-0.30			●	●							
	090208 LS3	2.0	0.05-0.5	0.05-0.30				●							
	110302 LS3	2.8	0.05-0.5	0.05-0.30	●										
	110304 LS	2.6	0.05-0.5	0.05-0.30		●	●								
	110304 LS3	2.6	0.05-0.5	0.05-0.30	●				●						
	110308 LS3	2.3	0.05-0.5	0.05-0.30	●		●								
	160404 LS3	2.8	0.05-0.5	0.05-0.30			●								



A49, A50,
A81-A83, A152, A155,
A167, A182, A210

●: Standard items





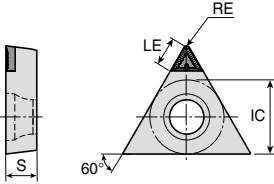

TCGW TPGN TCGT-CB



Positive triangular inserts



Size	Dimension (mm)		
	IC	S	RE
09	5.56	2.38	0.4-0.8
11	6.35	2.38-3.18	0.2-0.8
16	9.52	3.18-3.97	0.2-0.8

Insert	Designation	LE (mm)	ap (mm)	Feed (mm/rev)	CBN					PCD			
					TB610	TB650	TB670	TB730	TB7015	TB7020	TD1010	TD1020	TD1030
 	TCGW 090204 LN-7	3.3	0.1-2.0	0.05-0.30							●		
	090208 LN-7	3.0	0.1-2.0	0.05-0.30							●		
	110204 LN-7	3.8	0.1-2.0	0.05-0.30							●	●	●
	16T304 LN-7	3.8	0.1-2.0	0.05-0.30							●		
	16T308 LN-7	3.5	0.1-2.0	0.05-0.30							●		
 	TPGN 110302 LN-7	3.9	0.1-2.0	0.05-0.30							●		
	110304 LN-7	3.8	0.1-2.0	0.05-0.30							●		
	160302 LN-7	4.4	0.1-2.0	0.05-0.30							●		
	160304 LN-7	4.3	0.1-2.0	0.05-0.30							●		
  PCD chip breaker 	TCGT 090204 CB	2.8	0.5-1.5	0.10-0.50							●		
	110204 CB	3.8	0.5-2.0	0.10-0.50							●		
	16T304 CB	3.9	0.5-2.0	0.10-0.50							●		
	16T308 CB	3.6	0.5-2.0	0.10-0.50							●		

● Standard items

A81-A83,
A152, A155, A167,
A182, A210

VBGW VCGW VCGT-CB VCGT-CF



Positive 35° rhombic inserts

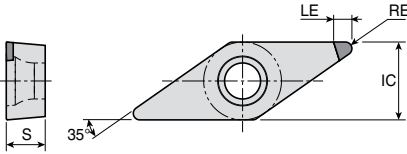

Size	Dimension (mm)		
	IC	S	RE
11	6.35	3.18	0.2-0.4
16	9.52	4.76	0.2-1.2
22	12.7	5.56	3.0

Insert	Designation	LE (mm)	ap (mm)	Feed (mm/rev)	CBN						PCD			
					TB610	TB650	TB670	TB730	TB7015	TB7020	TD1010	TD1020	TD1030	
	VBGW 110304 LS2	3.2	0.05-0.5	0.05-0.30			●							
	160402 LS2	3.6	0.05-0.5	0.05-0.30			●							
	160404 LS	3.2	0.05-0.5	0.05-0.30		●			●					
	160404 LS2	3.2	0.05-0.5	0.05-0.30	●		●	●						
	160408 LS	2.3	0.05-0.5	0.05-0.30		●			●					
	160408 LS2	2.3	0.05-0.5	0.05-0.30	●		●	●						
 	VBGW 160402 LN-7	5.2	0.1-2.0	0.05-0.30									●	
	160404 LN-7	5.0	0.1-2.0	0.05-0.30									●	
	160408 LN-7	4.2	0.1-2.0	0.05-0.30									●	
 	VCGW 160404 LN-7	5.0	0.1-2.0	0.05-0.30								●	●	●
	160408 LN-7	4.1	0.1-2.0	0.05-0.30								●	●	●
 	VCGT 110302 CB	4.7	0.5-2.0	0.10-0.50										●
	110304 CB	5.0	0.5-2.0	0.10-0.50										●
	160404 CB	7.3	0.5-3.5	0.10-0.50										●
	160408 CB	6.4	0.5-3.5	0.10-0.50										●
	160412 CB	6.2	0.5-3.5	0.10-0.50										●
 	VCGT 160404 CF	7.3	0.1-2.0	0.05-0.20										●
	160408 CF	6.4	0.1-2.0	0.05-0.20										●

A84, A85, A88-A90, A96, A98, A99, A138, A153, A187, A189, A191, A192, A211

●: Standard items



Recommended Cutting Conditions



Machining data for turning grades

ISO	Material	Condition	Tensile strength (N/mm ²)	Hardness HB	Material No.	
P	Non-alloy steel, cast steel, free cutting steel	<0.25%C	Annealed	420	125	1
		>=0.25%C	Annealed	650	190	2
		<0.55%C	Quenched and tempered	850	250	3
		>=0.55%C	Annealed	750	220	4
			Quenched and tempered	1000	300	5
	Low alloy steel and cast steel (less than 5% of alloying elements)		Annealed	600	200	6
			Quenched and tempered	930	275	7
				1000	300	8
				1200	350	9
	High alloy steel, cast steel and tool steel		Annealed	680	200	10
			Quenched and tempered	1100	325	11
M	Stainless steel and cast steel	Ferritic / martensitic	680	200	12	
		Martensitic	820	240	13	
		Austenitic	600	180	14	
K	Gray cast iron (GG)	Ferritic		160	15	
		Pearlitic		250	16	
	Cast iron nodular (GGG)	Ferritic		180	17	
		Pearlitic		260	18	
	Malleable cast iron	Ferritic		130	19	
	Pearlitic		230	20		
N	Aluminum - wrought alloy	Not cureable		60	21	
		Cured		100	22	
	Aluminum-cast, alloyed	<=12% Si	Not cureable		75	23
			Cured		90	24
		>12% Si	High temp.		130	25
	Copper alloys	>1% Pb	Free cutting		110	26
			Brass		90	27
			Electrolitic copper		100	28
Non-metallic		Duroplastics, fiber plastics		70 Shore D	29	
		Hard rubber		55 Shore D	30	
S	High temp. alloys	Fe based	Annealed		200	31
			Cured		280	32
		Ni or Co based	Annealed		250	33
			Cured		350	34
			Cast		320	35
	Titanium, Ti alloys		Pure	Rm 400	190	36
Alpha+beta alloys, hardened			Rm 1050	310	37	
H	Hardened steel	Hardened		55HRC	38	
		Hardened		60HRC	39	
	Chilled cast iron	Cast		400	40	
Cast iron nodular	Hardened		55HRC	41		

► For more information of material groups, see the materials & grades "material conversion table"

■ Steel
 ■ Stainless steel
 ■ Cast iron
 ■ Nonferrous
 ■ High temp. alloys
 ■ Hardened steel

Recommended Cutting Conditions



Machining data for turning grades

ISO	Material	Condition	Tensile strength (N/mm ²)	Hardness HB	Material No.	
P	Non-alloy steel, cast steel, free cutting steel	<0.25%C	Annealed	420	125	1
		>=0.25%C	Annealed	650	190	2
		<0.55%C	Quenched and tempered	850	250	3
		>=0.55%C	Annealed	750	220	4
			Quenched and tempered	1000	300	5
	Low alloy steel and cast steel (less than 5% of alloying elements)		Annealed	600	200	6
			Quenched and tempered	930	275	7
				1000	300	8
				1200	350	9
	High alloy steel, cast steel and tool steel		Annealed	680	200	10
			Quenched and tempered	1100	325	11
M	Stainless steel and cast steel	Ferritic / martensitic	680	200	12	
		Martensitic	820	240	13	
		Austenitic	600	180	14	
K	Gray cast iron (GG)	Ferritic		160	15	
		Pearlitic		250	16	
	Cast iron nodular (GGG)	Ferritic		180	17	
		Pearlitic		260	18	
	Malleable cast iron	Ferritic		130	19	
	Pearlitic		230	20		
N	Aluminum - wrought alloy	Not cureable		60	21	
		Cured		100	22	
	Aluminum-cast, alloyed	<=12% Si	Not cureable		75	23
			Cured		90	24
		>12% Si	High temp.		130	25
	Copper alloys	>1% Pb	Free cutting		110	26
			Brass		90	27
			Electrolitic copper		100	28
Non-metallic		Duroplastics, fiber plastics		70 Shore D	29	
		Hard rubber		55 Shore D	30	
S	High temp. alloys	Fe based	Annealed		200	31
			Cured		280	32
		Ni or Co based	Annealed		250	33
			Cured		350	34
			Cast		320	35
	Titanium, Ti alloys		Pure	Rm 400	190	36
Alpha+beta alloys, hardened			Rm 1050	310	37	
H	Hardened steel	Hardened		55HRC	38	
		Hardened		60HRC	39	
	Cast iron nodular	Cast		400	40	
	Cast iron nodular	Hardened		55HRC	41	

► For more information of material groups, see the materials & grades "material conversion table"

■ Steel
 ■ Stainless steel
 ■ Cast iron
 ■ Nonferrous
 ■ High temp. alloys
 ■ Hardened steel

Recommended Cutting Conditions



Machining data for turning grades

ISO	Material	Condition	Tensile strength (N/mm ²)	Hardness HB	Material No.	
P	Non-alloy steel, cast steel, free cutting steel	<0.25%C	Annealed	420	125	1
		>=0.25%C	Annealed	650	190	2
		<0.55%C	Quenched and tempered	850	250	3
		>=0.55%C	Annealed	750	220	4
			Quenched and tempered	1000	300	5
	Low alloy steel and cast steel (less than 5% of alloying elements)	Quenched and tempered	Annealed	600	200	6
				930	275	7
				1000	300	8
				1200	350	9
	High alloy steel, cast steel and tool steel	Annealed	680	200	10	
		Quenched and tempered	1100	325	11	
M	Stainless steel and cast steel	Ferritic / martensitic	680	200	12	
		Martensitic	820	240	13	
		Austenitic	600	180	14	
K	Gray cast iron (GG)	Ferritic		160	15	
		Pearlitic		250	16	
	Cast iron nodular (GGG)	Ferritic		180	17	
		Pearlitic		260	18	
	Malleable cast iron	Ferritic		130	19	
	Pearlitic		230	20		
N	Aluminum - wrought alloy	Not cureable		60	21	
		Cured		100	22	
	Aluminum-cast, alloyed	<=12% Si	Not cureable		75	23
			Cured		90	24
		>12% Si	High temp.		130	25
	Copper alloys	>1% Pb	Free cutting		110	26
			Brass		90	27
			Electrolitic copper		100	28
	Non-metallic		Duroplastics, fiber plastics		70 Shore D	29
Hard rubber				55 Shore D	30	
S	High temp. alloys	Fe based	Annealed		200	31
			Cured		280	32
		Ni or Co based	Annealed		250	33
			Cured		350	34
			Cast		320	35
	Titanium, Ti alloys	Pure		Rm 400	190	36
Alpha+beta alloys, hardened			Rm 1050	310	37	
H	Hardened steel	Hardened		55HRC	38	
		Hardened		60HRC	39	
	Chilled cast iron	Cast		400	40	
	Cast iron nodular	Hardened		55HRC	41	

► For more information of material groups, see the materials & grades "material conversion table"

■ Steel
 ■ Stainless steel
 ■ Cast iron
 ■ Nonferrous
 ■ High temp. alloys
 ■ Hardened steel

Recommended Cutting Conditions



Machining data for turning grades

Cutting speed Vc(m/min)								
Uncoated	Cermet		Ceramic					
K10	PV3010	CT3000	AW120	AB2010	AB20	AB30	TC430	TC3020
	350-650	300-570						
	270-520	250-500						
	240-480	220-460						
	260-500	240-470						
	240-460	220-440						
	240-540	220-520						
	190-330	170-300						
	170-300	150-270						
	140-270	130-250						
	260-405	250-395						
	140-205	130-195						
	200-300	180-270						
	200-270	170-250						
	170-260	150-240						
110-180	230-330	220-320				600-1200		
95-140	215-290	205-280				500-900		
95-135	145-220	135-200	600-1200			450-610		
90-125	105-150	95-140	500-900			350-510		
110-140	170-265	160-255	600-800			600-800		
90-125	180-240	170-230	500-700			500-700		
200-1000								
200-1000								
50-400								
50-500								
40-350								
50-500								
50-500								
30-300								
50-300								
50-150								
55-85								200-350
40-65								200-350
32-55							270-400	200-350
21-40							230-330	200-350
16-26							210-300	200-350
50-75								
45-70								
				95-145	90-140	50-100		
						60-120		
						50-100		

Recommended Cutting Conditions



Machining data for turning grades

ISO	Material	Condition	Tensile strength (N/mm ²)	Hardness HB	Material No.	
P	Non-alloy steel, cast steel, free cutting steel	<0.25%C	Annealed	420	125	1
		>=0.25%C	Annealed	650	190	2
		<0.55%C	Quenched and tempered	850	250	3
		>=0.55%C	Annealed	750	220	4
			Quenched and tempered	1000	300	5
	Low alloy steel and cast steel (less than 5% of alloying elements)		Annealed	600	200	6
			Quenched and tempered	930	275	7
				1000	300	8
				1200	350	9
	High alloy steel, cast steel and tool steel		Annealed	680	200	10
			Quenched and tempered	1100	325	11
M	Stainless steel and cast steel	Ferritic / martensitic	680	200	12	
		Martensitic	820	240	13	
		Austenitic	600	180	14	
K	Gray cast iron (GG)	Ferritic		160	15	
		Pearlitic		250	16	
	Cast iron nodular (GGG)	Ferritic		180	17	
		Pearlitic		260	18	
	Malleable cast iron	Ferritic		130	19	
	Pearlitic		230	20		
N	Aluminum - wrought alloy	Not cureable		60	21	
		Cured		100	22	
	Aluminum-cast, alloyed	<=12% Si	Not cureable		75	23
			Cured		90	24
		>12% Si	High temp.		130	25
	Copper alloys	>1% Pb	Free cutting		110	26
			Brass		90	27
			Electrolitic copper		100	28
	Non-metallic		Duroplastics, fiber plastics		70 Shore D	29
			Hard rubber		55 Shore D	30
S	High temp. alloys	Fe based	Annealed		200	31
			Cured		280	32
		Ni or Co based	Annealed		250	33
			Cured		350	34
			Cast		320	35
	Titanium, Ti alloys		Pure	Rm 400	190	36
Alpha+beta alloys, hardened			Rm 1050	310	37	
H	Hardened steel	Hardened		55HRC	38	
		Hardened		60HRC	39	
	Chilled cast iron	Cast		400	40	
	Cast iron nodular	Hardened		55HRC	41	

► For more information of material groups, see the materials & grades "material conversion table"

■ Steel
 ■ Stainless steel
 ■ Cast iron
 ■ Nonferrous
 ■ High temp. alloys
 ■ Hardened steel

Recommended Cutting Conditions



Machining data for turning grades

ISO	Material	Condition	Tensile strength (N/mm ²)	Hardness HB	Material No.	
P	Non-alloy steel, cast steel, free cutting steel	<0.25%C	Annealed	420	125	1
		>=0.25%C	Annealed	650	190	2
		<0.55%C	Quenched and tempered	850	250	3
		>=0.55%C	Annealed	750	220	4
			Quenched and tempered	1000	300	5
	Low alloy steel and cast steel (less than 5% of alloying elements)		Annealed	600	200	6
			Quenched and tempered	930	275	7
				1000	300	8
				1200	350	9
	High alloy steel, cast steel and tool steel		Annealed	680	200	10
			Quenched and tempered	1100	325	11
M	Stainless steel and cast steel	Ferritic / martensitic	680	200	12	
		Martensitic	820	240	13	
		Austenitic	600	180	14	
K	Gray cast iron (GG)	Ferritic		160	15	
		Pearlitic		250	16	
	Cast iron nodular (GGG)	Ferritic		180	17	
		Pearlitic		260	18	
	Malleable cast iron	Ferritic		130	19	
		Pearlitic		230	20	
N	Aluminum - wrought alloy	Not cureable		60	21	
		Cured		100	22	
	Aluminum-cast, alloyed	<=12% Si	Not cureable		75	23
			Cured		90	24
		>12% Si	High temp.		130	25
	Copper alloys		>1% Pb	Free cutting	110	26
				Brass	90	27
				Electrolitic copper	100	28
Non-metallic		Duroplastics, fiber plastics		70 Shore D	29	
		Hard rubber		55 Shore D	30	
S	High temp. alloys	Fe based	Annealed	200	31	
			Cured	280	32	
		Ni or Co based	Annealed	250	33	
			Cured	350	34	
			Cast	320	35	
	Titanium, Ti alloys		Pure	Rm 400	190	36
Alpha+beta alloys, hardened			Rm 1050	310	37	
H	Hardened steel	Hardened		55HRC	38	
		Hardened		60HRC	39	
	Chilled cast iron	Cast		400	40	
	Cast iron nodular	Hardened		55HRC	41	

► For more information of material groups, see the materials & grades "material conversion table"

■ Steel
 ■ Stainless steel
 ■ Cast iron
 ■ Nonferrous
 ■ High temp. alloys
 ■ Hardened steel

► Recommended clamping torque for each screw

Designation	Thread	Length	Torx / Hexa	Tightening Torque
TS 16031I	M1.6	3.12	Torx 6	0.6 Nm
TS 20038I	M2	3.8	Torx 6	0.6 Nm
TS 20038I/HG-P	M2	3.8	Torx plus 6	0.6 Nm
TS 20043I/HG-P	M2	4.3	Torx plus 6	0.6 Nm
TS 22046I	M2.2	4.6	Torx 7	0.9 Nm
TS 30080I/HG	M3	8	Torx 9	2 Nm
TS 30120I/HG	M3	12	Torx 9	2 Nm
TS 35070I/HG	M3.5	7	Torx 15	3 Nm
TS 35083I/HG	M3.5	8.3	Torx 10	2 Nm
TS 35110I	M3.5	11	Torx 15	3 Nm
TS 40097I	M4	9.7	Torx 15	3.5 Nm
TS 40G110I	M4	11	Torx 15	3.5 Nm
TS 40140AJ/HG	M4	14	Torx 15	3.5 Nm
TS 50A105I	M5	10.5	Torx 20	5.5 Nm
SO 22050I	M2.2	6	Torx 7	0.9 Nm
SO 25050I	M2.5	5.2	Torx 7	0.9 Nm
SO 25055I-MO	M2.5	6	Torx 8	1.2 Nm
SO 25065I	M2.5	6.5	Torx 7	0.9 Nm
SO 30055I	M3	5.5	Torx 9	2 Nm
SO 30100I	M3	7	Torx 9	2 Nm
SO 30040I	M3	8.3	Torx 9	2 Nm
SO 35080I	M3.5	8.5	Torx 15	3 Nm
SO 35124I	M3.5	11.7	Torx 15	3 Nm
SO 35120I	M3.5	12	Torx 10	2 Nm
SO 40073I	M4	7.3	Torx 15	3.5 Nm
SO 40085I	M4	8.5	Torx 15	3.5 Nm
SO 40090I	M4	8.6	Torx 15	3.5 Nm
SO 40050I	M4	11.3	Torx 15	3.5 Nm
SO 45100I	M4.5	10	Torx 20	5 Nm
SO 45130I	M4.5	14.3	Torx 20	5 Nm
SO 50090I-MO	M5	8	Torx 20	5 Nm
SO 50090I	M5	12.1	Torx 20	5.5 Nm

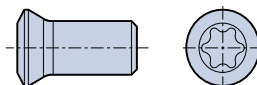

Designation	Thread	Length	Torx / Hexa	Tightening Torque
BH M2.5X0.45X10	M2.5	11.5	Hexa 1.5mm	0.8 Nm
BH M4X0.7X16-TB	M4	19	Hexa 3mm	2.8 Nm
BH M5X0.8X10	M5	13.55	Hexa 3mm	5.5 Nm
BH M5X0.8X21-MO-TB	M5	24.55	Hexa 3mm	5.5 Nm
BH M6X1X25	M6	29.2	Hexa 4mm	9.5 Nm

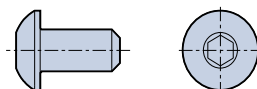

► Recommended clamping torque for each screw

Designation	Thread	Length	Torx / Hexa	Tightening Torque
LCS 2	M5x0.8	14	Hexa 2mm	2.5 Nm
LCS 2B	M5x0.8	10	Hexa 2mm	2.5 Nm
LCS 3	M6x1.0	16.5	Hexa 2.5mm	3 Nm
LCS 3B	M5x0.8	12	Hexa 2mm	2.5 Nm
LCS 4	M8x1.0	21	Hexa 3mm	4 Nm
LCS 4B	M6x1.0	13.5	Hexa 2.5mm	3 Nm
LCS 4S	M8x1.0	18	Hexa 3mm	4 Nm
LCS 5	M8x1.0	23	Hexa 3mm	4 Nm
LCS 6	M10x1.0	27	Hexa 4mm	6 Nm
LCS 8	M12	36	Hexa 5mm	10 Nm
LCS 8-L39	M12	39	Hexa 5mm	10 Nm
LCS 8-L43	M12	43	Hexa 5mm	10 Nm
LCS 16C	M6	21	Hexa 2.5mm	3 Nm
LCS 25C	M10	30	Hexa 4mm	6 Nm

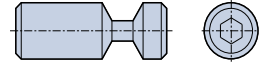

Designation	Thread	Length	Torx / Hexa	Tightening Torque
CLS 1.25	M3	4.7	Hexa 1.5mm	2 Nm
CLS 2C	M4	7.6	Hexa 2.5mm	2.5 Nm
CLS 2	M5	6.3	Hexa 2.5mm	3 Nm
CLS 3C	M5	9.5	Hexa 3mm	3.5 Nm
CLS 3S	M6	4.5	Hexa 3mm	4 Nm
CLS 3	M6	9.8	Hexa 3mm	4 Nm
CLS 4	M8	22	Hexa 4mm	8 Nm
CLS 16K	1/4-20 UNC	12	Hexa 4mm	6 Nm

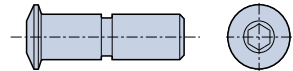

Designation	Thread	Length	Torx / Hexa	Tightening Torque
CSC 4	1/4-20 UNC	17	Hexa 4mm	6 Nm

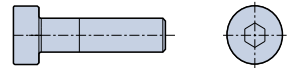

Designation	Thread	Length	Torx / Hexa	Tightening Torque
DLS 3	M4	16.8	Hexa 2.5mm	2 Nm
DLS 4	M5	21	Hexa 3mm	4.2 Nm
DLS 5	M6	26.5	Hexa 4mm	6 Nm

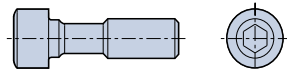

Designation	Thread	Length	Torx / Hexa	Tightening Torque
WCS 2.5	M5	20	Hexa 2.5mm	3 Nm
WCS 4	M6	26	Hexa 3mm	4 Nm
WCS 4B	M6	22.5	Hexa 3mm	4 Nm

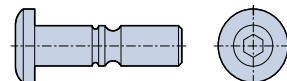



PARTING & GROOVING



PARTING & GROOVING



contents

Tool Selection Guide

Holder Selection Guide	B4
Insert Selection Guide	B19
Grades	B26
Chip Breakers	B28
Toolholders	
WIN-CUT	B34
CUT-SFEED	B38
T-CLAMP	B42
WIN-SWISS	B64
FACE-RUSH	B97
T-GROOVE	B101
TOP-CUT	B102
QUAD-RUSH	B104
QUAD-I-RUSH	B118
WIN-I-GROOVE	B120
MINI-I-RUSH	B121
COOL-BURST Accessories	B122

Guide to Icons



➤ Holder Page



➤ Sleeve Page



➤ Insert Page



➤ Cutting Condition Page

















Inserts and Solid Bars

Insert Designation System	B126
CUT-SFEED	B128
T-CLAMP	B129
VT-CLAMP	B134
FACE-RUSH	B146
T-GROOVE	B147
QUAD-RUSH Designation System	B148
QUAD-RUSH	B149
QUAD-I-RUSH	B162
WIN-I-GROOVE	B163
MINI-I-RUSH	B163
TOP-CUT Designation System	B164
TOP-CUT	B165
TOP-MICRO Designation System	B168
TOP-MICRO	B169
Tailor-made Designation System	B181
Tailor-made Insert	B182
Technical Data	B186
Recommended Cutting Conditions	B187







Tool Selection Guide

Parting, Grooving and Turning holders

				WINCUT		CUTSPEED	
				COOLBURST SFTB SFTB-TB	COOLBURST TGTB TGTB-TB	SFGB	COOLBURST SFGB-TB
Series							
Pages				B34	B35	B38	B39
Application	External	Parting		•	•	•	•
		Grooving		•	•	•	•
		Turning					
	Facing	Grooving					
		Turning					
	Internal	Grooving					
		Turning					
	Profiling						
	Threading						
	Undercut						

Tool Selection Guide

Parting, Grooving and Turning holders

CUT SPEED		T-CLAMP			
SFER/L	COOLBURST SFER/L-TB	TGB	COOLBURST TGB-TB	TGBR/L TGBR/L-D..R/L TGBR/L-TI-D..R/L	TGBFR/L
					
B40	B41	B42	B43	B44-B46	B47
●	●	●	●	●	
●	●	●	●	●	
					●

● Recommended, ○ Suitable







Tool Selection Guide

Parting, Grooving and Turning holders

Series				T-CLAMP			QUAD-RUSH	
				TGER/L	TCAER/L	COOLBURST TCAER/L-TB	TCAFR/L	TCAQR/L
Pages				B48	B52	B53	B54	B55-B56
Application	External	Parting		●	●	●		●
		Grooving		●	●	●		●
		Turning			●	●		○
	Facing	Grooving					●	
		Turning					●	
	Internal	Grooving						
		Turning						
	Profiling			●	●			○
	Threading							●
	Undercut							

Tool Selection Guide

Parting, Grooving and Turning holders

QUAD RUSH <i>COOLBURST</i> TCAQR/L-TB	QE1 TTER/L QE1 TTER/L-TB	WINSWISS QE1 TQHR/L QE1 TQHR/L-TB	QE1Y TQHR QE1Y TQHR-TB	HUSHBORE <i>COOLBURST</i> QH TTIR/L-TB	T-CLAMP TTER/L-SH
					
B55-B56	B64-B65	B66	B67	B70	B72
●	●	●	●		●
●	●	●	●		●
○	●	●	●		●
				●	
				●	
○	●	○	○		●
●		●	●		

● Recommended, ○ Suitable

Tool Selection Guide







Parting, Grooving and Turning holders

Series				T-CLAMP			
				COOLBURST TTER/L-SH-TB	TTER/L-D	TTER/L	COOLBURST TTER/L-TB
Pages				B73	B74-B75	B76-B77	B78
Application	External	Parting		●	●	●	●
		Grooving		●	●	●	●
		Turning		●	●	●	●
	Facing	Grooving					
		Turning					
	Internal	Grooving					
		Turning					
	Profiling			●	●	●	●
	Threading						
	Undercut						

Tool Selection Guide

Parting, Grooving and Turning holders















T-CLAMP
Tool Holder

<u>TTSER/L</u>	<u>TGFR/L</u>	<u>TTFR/L</u>	<u>TTFR/L-RN</u>	<u>TGFPR/L</u>	<u>TTFPR/L</u>
					
B79	B80	B81	B82-B83	B84	B85
○					
●	●			●	
●	○			○	
	●	●	●	●	●
	○	●	●	○	●
○					

● Recommended, ○ Suitable

Tool Selection Guide







Parting, Grooving and Turning holders

				T-CLAMP			
				<u>TGIFR/L</u>	<u>TTFIR/L</u>	<u>TTIR/L-C</u> <u>TTIR/L</u>	COOLFIRST <u>TTIR/L-TB</u>
Series							
Pages				B86	B87	B88-B89	B90
Application	External	Parting					
		Grooving					
		Turning					
	Facing	Grooving		●	●		
		Turning		○	●		
	Internal	Grooving				●	●
		Turning				●	●
	Profiling						
	Threading						
	Undercut						

Tool Selection Guide

Parting, Grooving and Turning holders















T-CLAMP
Tool - Clamp

<u>TTSIR/L</u>	<u>TGSIR/L</u>	<u>TGEUR/L</u>	<u>TGIUR/L</u>	<u>TTER/L-15A</u>	<u>TGIUR/L-15A</u>
					
B91	B92	B93	B94	B95	B96
●	●				
●			○		
				●	●
		●	●		

● Recommended, ○ Suitable





Tool Selection Guide

Parting, Grooving and Turning holders

Series							
				 TXFR/L	 TXFR/L-TB	 TXFPR/L	 TXFPR/L-TB
Pages				B97	B98	B99	B100
Application	External	Parting					
		Grooving		○	○		
		Turning		○	○		
	Facing	Grooving		●	●	●	●
		Turning		●	●	●	●
	Internal	Grooving					
		Turning					
	Profiling						
	Threading			○	○		
	Undercut						

Tool Selection Guide













Parting, Grooving and Turning holders

T <i>GROOVE</i>	TOP <i>CUT</i>		QUAD <i>RUSH</i>	
<u>TTLEN</u>	<u>TTVER/L</u>	<u>TTVBR/L</u>	<u>TQHR/L-20</u>	<u>TQHR/L-20-TB</u>
				
B101	B102	B103	B104	B105
	●		●	●
●	●		●	●
	●	●	○	○
			○	○
		●	●	●

● Recommended, ○ Suitable





Tool Selection Guide

Parting, Grooving and Turning holders

				 			
				<u>TQHR/L-20-Q</u>	<u>TQHR/L-20-TB-Q</u>	<u>TMS-TQHL</u>	<u>TMS-TQHL-TB</u>
Series							
Pages				B104	B105	B106	B107
Application	External	Parting		●	●		
		Grooving		●	●	●	●
		Turning		○	○	○	○
	Facing	Grooving					
		Turning					
	Internal	Grooving					
		Turning					
	Profiling		○	○	○	○	
	Threading		●	●	○	○	
	Undercut						

Tool Selection Guide















Parting, Grooving and Turning holders

<i>QUADRUSH</i>				
<u>TMY TQHR</u>	<i>COOLBURST</i> <u>TMY TQHR-TB</u>	<u>TQBR/L-27</u>	<u>TQHR/L-27</u>	<i>COOLBURST</i> <u>TQHR/L-27-TB</u>
				
B108	B109	B110	B111	B112
●	●	●	●	●
●	●	●	●	●
○	○		○	○
○	○		○	○
●	●		●	●

● Recommended, ○ Suitable













Tool Selection Guide

Parting, Grooving and Turning holders

							
				 <u>TQHPR/L-27</u>	 <u>TQHR/L-34</u>	 <i>COOLBURST</i> <u>TQHR/L-34-TB</u>	 <u>TQHPR/L-34</u>
Series							
Pages				B113	B114	B115	B116
Application	External	Parting		●	●	●	●
		Grooving		●	●	●	●
		Turning		○	○	○	○
	Facing	Grooving					
		Turning					
	Internal	Grooving					
		Turning					
	Profiling		○	○	○	○	
	Threading		●				
	Undercut						

Tool Selection Guide

Parting, Grooving and Turning holders

					
 TQHR/L...EW-TB	TQHR/L	TMS-TQHIL	 TMS-TQHIL-TB	TMIHR/L TMIHR/L-C	TMIHN TMIHN-C
					
B117	B118	B119	B119	B120	B121
●		●	●		
		○	○		
	●			●	●
	○			○	○

● Recommended, ○ Suitable

Tool Selection Guide















Internal application by diameter

Internal diameter (mm)	TOPMICRO	WINGROOVE	MINIRUSH	TOPCAP	T-CLAMP	QUADRUSH	T-CLAMP
	MIN	TMIHR/L	TMIHN	TCAP	TTSIR/L	TQHIR/L	TTIR/L
0							
0.6							
1							
2							
3							
4							
5							
6							
7							
8							
9							
10							
11							
12							
12.5							
13							
14							
15							
16							
17							
18							
19							
20							
21							
22							
23							
24							
25							
26							



Tool Selection Guide











Parting, Grooving and Turning Inserts

			CUT SPEED		T-CLAMP			
			SFC	SFJ	TDC	TSC	TDJ	
Series								
Material			P M K N S	P M N S	P M K N S	P M K N S	P M N S	
Pages			B128	B128	B129	B130	B131	
Application	External	Parting		●	●	●	●	●
		Grooving		●	●	●	●	●
		Turning						
	Facing	Grooving				○	○	○
		Turning						
	Internal	Grooving				○	○	○
		Turning						
	Profiling							
	Threading							
	Undercut							

● Recommended, ○ Suitable

Tool Selection Guide

Parting, Grooving and Turning Inserts

Series			T-CLAMP				VT-CLAMP	
			TSJ	TDUF	TDV	TDCT	TDMV	
Material			P M N S P		P M N S	P M K N S	P M K N S	
Pages			B132	B133	B133	B134	B134	
Application	External	Parting		●	●	●	●	○
		Grooving		●	●	●	●	○
		Turning					●	●
	Facing	Grooving		○	○	○	●	
		Turning					●	
	Internal	Grooving		○	○	○	●	
		Turning					●	●
	Profiling						●	
	Threading							
	Undercut						●	

Tool Selection Guide

Parting, Grooving and Turning Inserts

















TDXU	TDXT	TDXY	TDT	TDT (Round Type)	TDT - RU (Round Type)	TDT - RS (Round Type)	TST - RS (Round Type)
P M K N S	P M K N S	P M K S	P M K N S	P M K N S	P M K S	P M K N S	P M K N S
B135	B135	B136	B137-B138	B139	B139	B140	B140
○	○	○	○				
●	●	●	●	●	●	●	●
●	●	●	●	●	●	●	●
●	●	●	○				
●	●	●	○				
●	●	●	○				
				●	●	●	●
				●	●	●	●

● Recommended, ○ Suitable









Tool Selection Guide

Parting, Grooving and Turning Inserts

Series			T-CLAMP <small>For a Turn of Mind</small>					
			TDFT	TDIT	TDIM	TDIP	TSG (CBN)	
								
Material			P M K N S	P M K N S	P M K N	P M K N S	H	
Pages			B141	B141-B142	B142	B143	B144	
Application	External	Parting						
		Grooving				●	●	●
		Turning				○	○	●
	Facing	Grooving		●		○	○	
		Turning		●				
	Internal	Grooving			●	●	●	
		Turning			●	●	●	
	Profiling						○	●
	Threading							
	Undercut				○			

Tool Selection Guide











Parting, Grooving and Turning Inserts

T-CLAMP			FACE RUSH		T-GROOVE	QUAD RUSH	
TSG-HF (CBN)	TDA	TSA (PCD)	TDFX	TDGX	TGUX	TQJ 20	TQS 20
							
	H N	N	P M K N S	P M N S	P M K N	P M N S	P M K N S
B144	B145	B145	B146	B146	B147	B149	B150
						●	●
○	○		○		●	●	●
●	●		○			●	●
			●				
			●				
	●	●					○
				●			
	○						

● Recommended, ○ Suitable









Tool Selection Guide

Parting, Grooving and Turning Inserts

Series			QUAD RUSH					
			TQS 20-MT	TQJ 27	TQC 27	TQS 27	TQS 27-MT TQS 27-WT	
Material			P M N S	P M N S	P M K N S	P M K N S	P M N S	
Pages			B150	B151-B153	B154-B155	B156	B157	
Application	External	Parting			●	●	●	
		Grooving			●	●	●	
		Turning			●	●	●	
	Facing	Grooving						
		Turning						
	Internal	Grooving						
		Turning						
	Profiling			○	○	○		
	Threading		●				●	
	Undercut							

Tool Selection Guide

Parting, Grooving and Turning Inserts

	QUAD RUSH		QUAD RUSH	WIN GROOVE	MINI RUSH	TOP CUT	TOP MICRO
TQS 27-ISO TQS 27-UN TQS 27-W	TQBS 27	TQC 34	TQIS 14	TMIR/L	TMIS 8	TV..	MIN.
							
P M N S	P M K N	P M K N S	P M K N S	P M K N S	P M K N S	P M N S	P M N S
B158-B159	B159	B160-B161	B162	B163	B163	B164-B167	B168-B180
		●				●	
	●	●	○			●	
		●				●	
			●	●	●		●
			○	○	○		●
		○					●
●						●	●

● Recommended, ○ Suitable

Grades

Selection guide for parting and grooving grades

For steel (PVD & CVD coated)

Cutting speed

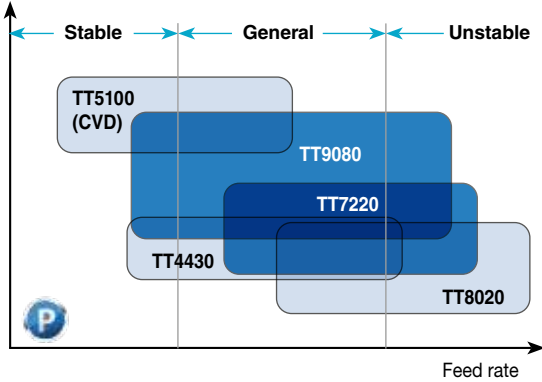

For stainless steel & super alloy (PVD coated)

Cutting speed

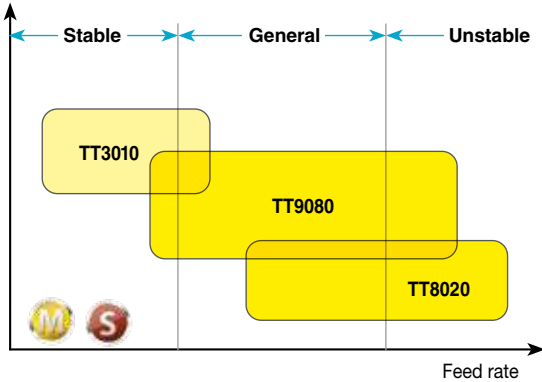

For cast iron (PVD & CVD coated)

Cutting speed

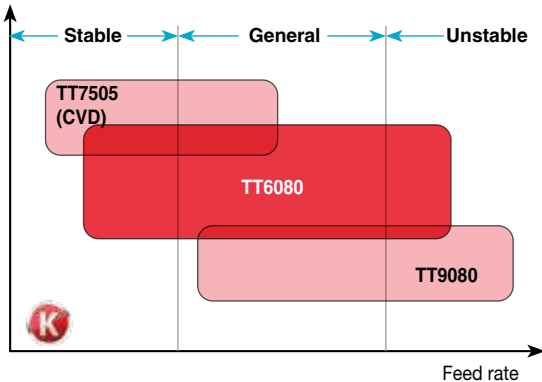







Grades

Parting and grooving grades

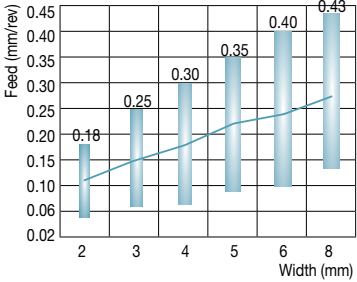
Grades	ISO	Characteristics & applications
TT7505 CVD coated	K05 – K15	<ul style="list-style-type: none"> High speed grooving and turning of gray and ductile cast iron
TT6080 PVD coated	K05 – K25 H05 – H25	<ul style="list-style-type: none"> General machining of gray and ductile cast iron for grooving and turning Finish and medium machining of hardened steel
TT3010 PVD coated	S05 – S20	<ul style="list-style-type: none"> High speed grooving and turning of heat-resistant super alloy
TT5100 CVD coated	P20 – P35 M20 – M35	<ul style="list-style-type: none"> Medium grooving and turning of mild steel, low carbon steel and low carbon alloy steel Low to medium speed machining of stainless steel
TT9080 PVD coated	P20 – P40 M20 – M40 S20 – S40	<ul style="list-style-type: none"> General machining of steel, stainless steel and heat-resistant super alloy for parting, grooving and turning Continuous cut and medium cutting speed
TT4430 PVD coated	P20 – P40 M20 – M40 S20 – S40	<ul style="list-style-type: none"> General machining of steel, stainless steel and heat-resistant super alloy for small parts Grooving, turning and parting
TT7220 PVD coated	P25 – P45 M25 – M45	<ul style="list-style-type: none"> Rough machining of steel and stainless steel for parting, grooving and turning
TT8020 PVD coated	P30 – P50 M30 – M50 S30 – S50	<ul style="list-style-type: none"> Low speed or rough and interrupted machining of steel, stainless steel and heat-resistant super alloy for parting, grooving and turning
CT3000 Cermet	P10 – P20 M10 – M20 K10 – K20	<ul style="list-style-type: none"> Good surface finish turning of steel, stainless steel and cast iron
K10 Carbide	K05 – K15 N05 – N15 S05 – S15	<ul style="list-style-type: none"> General machining of cast iron, aluminum alloys, non-ferrous materials and titanium alloys
TB2015 CBN	H10 – H20	<ul style="list-style-type: none"> Continuous and light interrupted machining of hardened steel
TD1020 PCD	N10 – N25	<ul style="list-style-type: none"> General machining of aluminum alloys

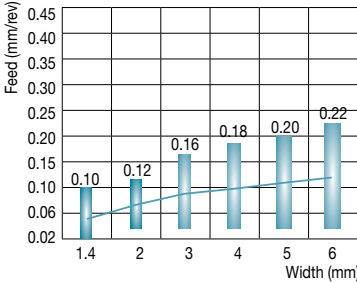
Chip Breakers

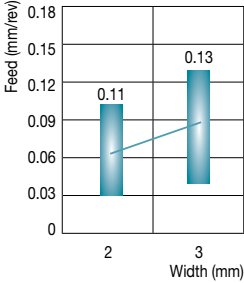
Parting and grooving

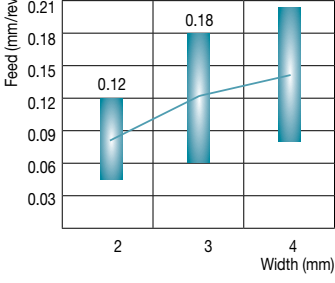
Chip breakers	Applications and features
<p>C-Type</p> 	 <ul style="list-style-type: none"> • 1st choice for general use in parting and deep grooving • Stable cutting edge & interrupted cut • Medium-to-high feed • For carbon steel, alloy steel and cast iron • For hard materials
<p>J-Type</p> 	 <ul style="list-style-type: none"> • 1st choice for soft materials in parting and deep grooving • Sharp cutting edge & low cutting force • Low-to-medium feed • Tubes, small diameter and thin-wall parts • For stainless steel & low carbon steel • For heat resistant super alloy
<p>UF-Type</p> 	 <ul style="list-style-type: none"> • Narrow chip breaker • Good chip control in low feed of ductile materials and low carbon steel • For Cr-Ni alloy steel and bearing steel
<p>V-Type</p> 	 <ul style="list-style-type: none"> • Sharp cutting edge and wide groove with minimized burrs • For tubes of small size workpieces • For stainless steel and mild steel

Chip Breakers

Groove-Turn

Chip breakers	Applications and features
---------------	---------------------------

CT-Type



■ Grooving

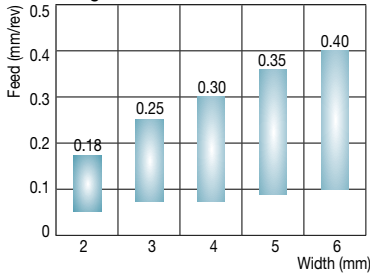

- Stable cutting edge in grooving and parting
- Covers C-type chip breaker applications including a built-in chip breaker for turning applications
- Medium-to-high feed range
- Steel, cast iron, stainless steel and heat resistant alloys

■ Turning

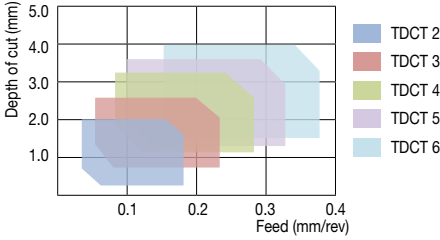

XU-Type



■ Grooving

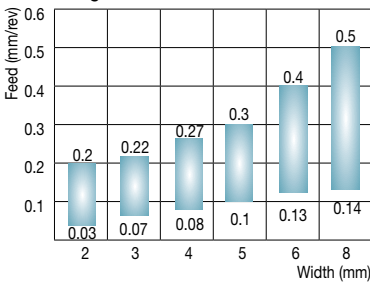

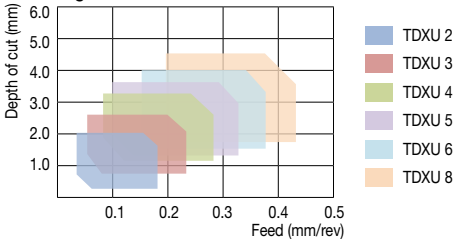

- 1st choice for general use in groove-turn
- Multi functional chip breaker for external, internal and face machining
- Low cutting force and good chip control
- Medium-to-high feed grooving, low-to-medium feed turning
- Steel, stainless steel and heat resistant alloy

■ Turning

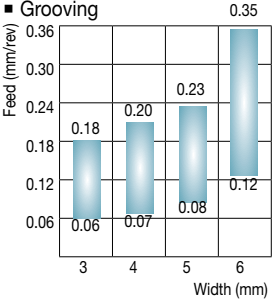
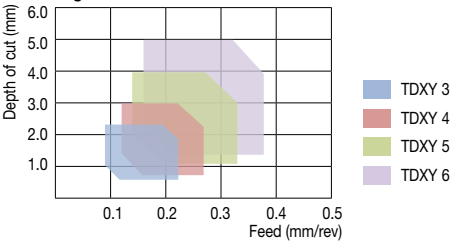

Chip Breakers

Groove-Turn

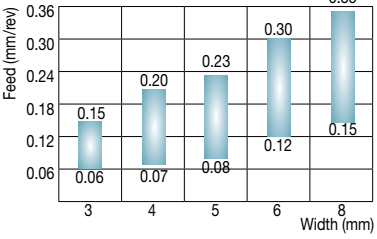
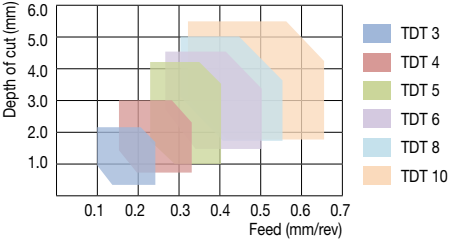
Chip breakers	Applications and features
<p>XY-Type</p> 	<p>■ Grooving</p>  <p>■ Turning</p>  <ul style="list-style-type: none"> • For external and internal grooving as well as turning applications • Good chip control when external face grooving and turning • Flat bottom surface machining • Low-to-medium feed grooving, medium-to-high feed turning • Ideal for steel, stainless steel, cast iron and super alloys machining
<p>T-Type</p> 	<p>■ Grooving</p>  <p>■ Turning</p>  <ul style="list-style-type: none"> • 1st choice for side turning of cast iron • Turning and grooving with various geometry • Steel and cast iron • High feed rate

Chip Breakers

Groove-Turn

Chip breakers

Applications and features

MV-Type



■ Backward turning

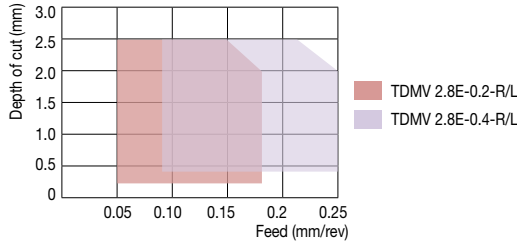

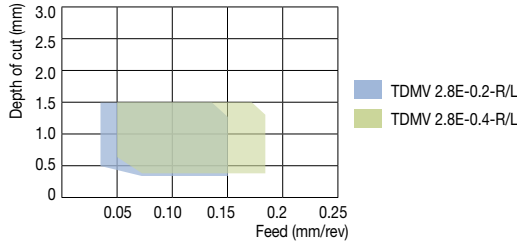

■ Forward turning



- Versatile chip breaker: forward/backward turning, profiling, end facing and parting
- Optimized chip breaker design for bi-directional turning enables superior chip control
- Insert's 2.8 mm edge width allows for a variety of tasks in tight spaces
- Roughing and finishing capable with a cutting depth of up to 2.5 mm
- Available in 4 insert types: R/L-handed, Corner R0.2, R0.4
- Multi-application machining reduces tool cost and equipment downtime while maximizing productivity gains
- Compatible with standard holders, maximizing performance when using internal high-pressure feed-type holders

Chip Breakers

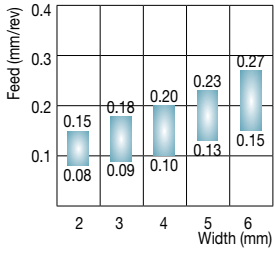
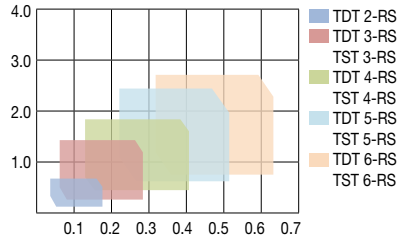
Groove-Turn

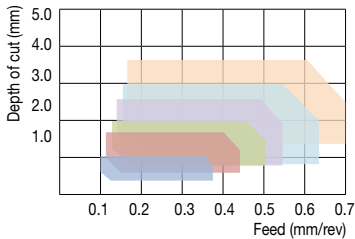
Chip breakers	Applications and features
<p>RS-Type</p> 	<p>■ Grooving</p>  <p>■ Turning</p>  <ul style="list-style-type: none"> • 1st choice for medium to finishing machining of heat-resistant super alloys • For external and internal profiling, turning and grooving applications • Low cutting force and good surface finish due to the sharp edge • Precision machining and excellent repeatability
<p>RU-Type</p> 	<p>■ Turning</p>  <ul style="list-style-type: none"> • Profiling in steel and cast iron • Tough cutting edge • Good chip control even in low depth • Good surface finish • High feed rate and low depth of cut

Parting & Grooving Toolholders



SFTB

Triangular blades for parting and deep grooving

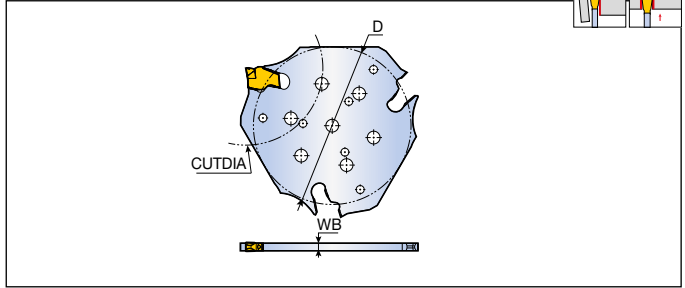

Designation	Insert seat size	Dimension (mm)			Block	Insert
		D	WB	CUTDIA		
SFTB D52-2	2	53.2	1.8	52	THTBR/L-TB	SFC
D52-3	3	53.2	2.5	52	THTBR/L-R/L-TB	SFJ
D82-2	2	64.3	1.8	82	B36-B37	B128
D82-3	3	64.3	2.5	82		
D120-2	2	85.5	1.8	120		
D120-3	3	85.5	2.5	120		

SFTB-TB

Triangular blades for parting and deep grooving with high pressure coolant

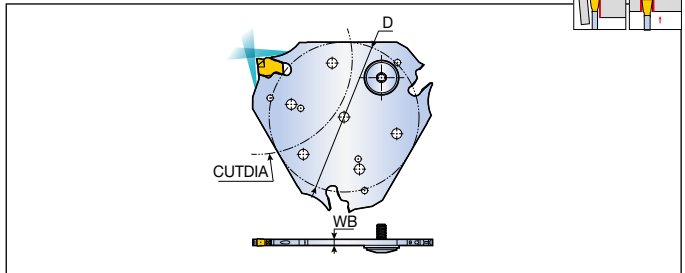

Designation	Insert seat size	Dimension (mm)			Block	Insert
		D	WB	CUTDIA		
SFTB D52-2-TB	2	53.2	1.8	52	THTBR/L-TB	SFC
D52-3-TB	3	53.2	2.5	52	THTBR/L-R/L-TB	SFJ
D82-2-TB	2	64.3	1.8	82	B36-B37	B128
D82-3-TB	3	64.3	2.5	82		
D120-2-TB	2	85.5	1.8	120		
D120-3-TB	3	85.5	2.5	120		

Spare parts

Designation	Sealing screw set	Extractor		
SFTB	-	ETG 3-4		
SFTB-TB	SGC 340-Q	ETG 3-4		

► Extractor should be ordered separately

TGTB

Triangular blades for parting and deep grooving

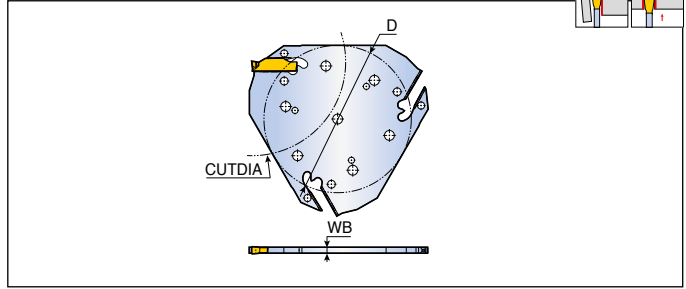

Designation	Insert seat size	Dimension (mm)			Block	Insert
		D	WB	CUTDIA		
TGTB D52-2	2	53.2	1.8	52	THTBR/L-TB	TDC/J/V/UF
D52-3	3	53.2	2.5	52	THTBR/L-R/L-TB	TSC/J
D82-2	2	64.3	1.8	82	B36-B37	TDCT/XU/XY/XT/T
D82-3	3	64.3	2.5	82		B129-B140

TGTB-TB

Triangular blades for parting and deep grooving with high pressure coolant

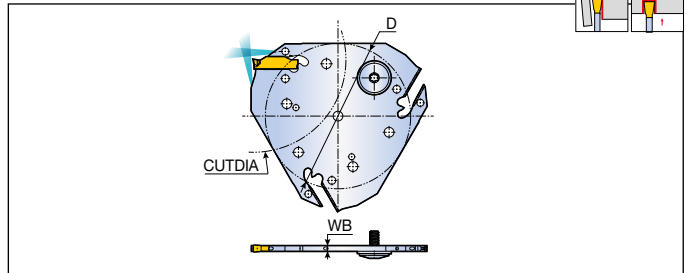

Designation	Insert seat size	Dimension (mm)			Block	Insert
		D	WB	CUTDIA		
TGTB D52-2-TB	2	53.2	1.8	52	THTBR/L-TB	TDC/J/V/UF
D52-3-TB	3	53.2	2.5	52	THTBR/L-R/L-TB	TSC/J
D82-2-TB	2	64.3	1.8	82	B36-B37	TDCT/XU/XY/XT/T
D82-3-TB	3	64.3	2.5	82		B129-B140

Spare parts

Designation	Sealing screw set	Extractor		
TGTB	-	EDG 33B		
TGTB-TB	SGC 340-Q	EDG 33B		

▶ Extractor should be ordered separately

THTBR/L-TB

Blocks for triangular blade

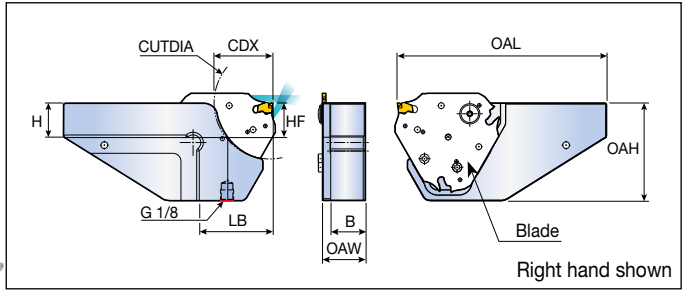

Designation	Dimension (mm)								Blade
	H	HF	B	OAL	OAH	OAW	LB	CUTDIA	
THTBR/L 20-D52-TB	20	20	17.5	125	52	23.5	40	52	SFTB/SFTB-TB TGTB/TGTB-TB B34-B35
25-D52-TB	25	25	22.5	135	52	28.5	40	52	
20-D82-TB	20	20	17.5	140	72	23.5	51.5	82	
25-D82-TB	25	25	22.5	150	72	28.5	51.5	82	
25-D120-TB	25	25	22.5	165	95	28.5	67	120	
32-D120-TB	32	32	29.0	165	95	35.0	67	120	

► Please refer to B122 page for COOL-BURST accessories

Table determining depth of cut for grooving as function of workpiece diameter

Designation	CUTDIA											
	CDX	5	6	7	8	9	10	11	12	13	14	15
SFTB/TGTB D52	240	164	137	118	105	94	86	80	74	70	66	
D82	N.L.	N.L.	3686	1126	734	524	408	335	284	247	219	
SFTB D120	N.L.	N.L.	7752	2581	1548	1105	860	704	597	518	458	

► N.L.: No limit

Designation	CUTDIA											
	CDX	16	17	18	19	20	21	22	23	24	25	26
SFTB/TGTB D52	64	61	59	57	56	55	54	53	52	52	52	
D82	197	180	166	154	144	135	128	122	116	112	108	
SFTB D120	411	373	342	316	294	276	259	245	233	222	212	

Designation	CUTDIA															
	CDX	27	28	29	30	31	32	33	34	35	36	37	38	39	40	41
SFTB/TGTB D82	104	101	98	96	93	91	90	88	87	86	85	84	83	82	82	
SFTB D120	203	195	188	182	176	171	166	162	158	154	151	148	145	143	140	

Designation	CUTDIA														
	CDX	42	43	44	45	46	47	48	49	51	52	55	54-53	57-56	58-60
SFTB D120	136	134	133	131	130	128	127	126	125	124	122	123	121	120	

Spare parts

Designation	Locating pin	Screw	O-Ring	Wrench
THTBR/L-TB	SIDE THRUST PIN 3MM	SH M4X0.7X10-TX	O-RING ID10X2	T 20

THTBR-L-TB / THTBL-R-TB

Blocks for triangular blade for machining next to spindle

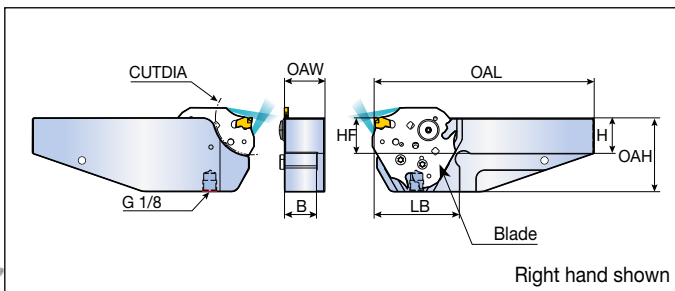

Designation	Dimension (mm)								Blade
	H	HF	B	OAL	OAH	OAW	LB	CUTDIA	
THTBR 25-L-D52-TB	25	25	22.5	155	52	28.5	60	52	SFTB/SFTB-TB TGTB/TGTB-TB B34-B35
25-L-D82-TB	25	25	22.5	176.5	72	28.5	78	82	
25-L-D120-TB	25	25	22.5	211	95	28.5	113	120	
THTBL 25-R-D52-TB	25	25	22.5	155	52	28.5	60	52	
25-R-D82-TB	25	25	22.5	176.5	72	28.5	78	82	
25-R-D120-TB	25	25	22.5	211	95	28.5	113	120	

► Please refer to B122 page for COOL-BURST accessories

Spare parts

Designation	Locating pin	Screw	O-Ring	Wrench
THTBR/L--R/L-TB	SIDE THRUST PIN 3MM	SH M4X0.7X10-TX	O-RING ID10X2	T 20

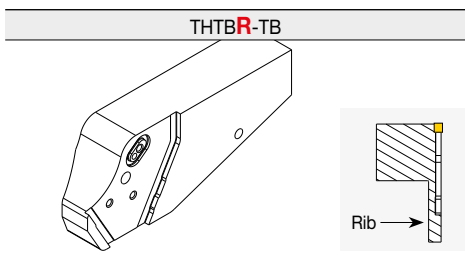

R-Pocket orientation

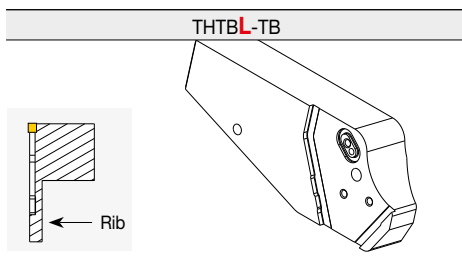

L-Pocket orientation

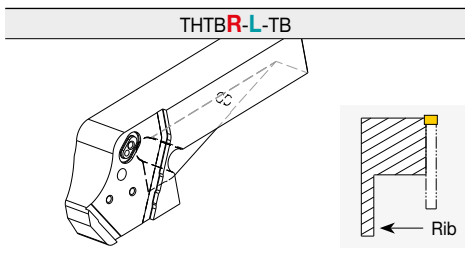

R-Pocket orientation / **L**-Reinforcement rib side

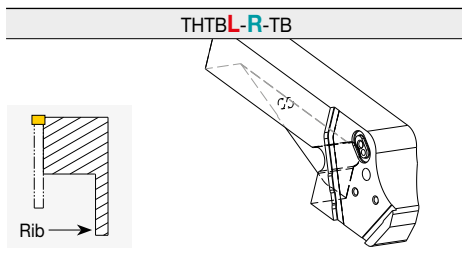

L-Pocket orientation / **R**-Reinforcement rib side

TGB-TB

Blades for parting and deep grooving with high pressure coolant



COOLBURST

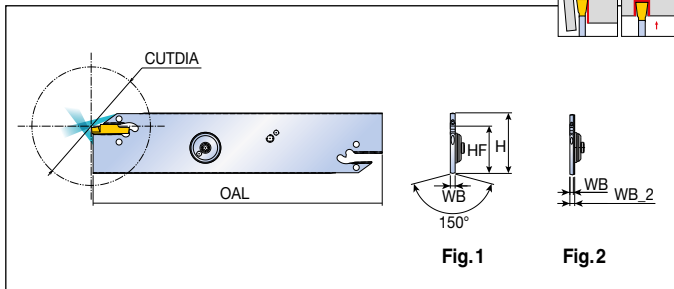

Designation	Insert seat size	Dimension (mm)						Fig.	Block	Insert
		H	HF	OAL	WB	WB_2	CUTDIA			
TGB 32-2-TB	2	32	24.9	150	1.8	2.5	50	2	TTBU..-TB B51	TDC/J/V/UF
32-3-TB	3	32	24.9	150	2.5	-	90	1		TSC/J
32-4-TB	4	32	24.9	150	3.2	-	90	1		TDCT/XU/XY/XT/T
32-5-TB	5	32	24.9	150	4.0	-	110	1		B129-B140
32-6-TB	6	32	24.9	150	5.2	-	110	1		

Spare parts

Designation	Sealing screw set	Extractor		
TGB-TB	SGC 340	EDG 33B		

► Extractor should be ordered separately

TGBR/L -D..R/L

Reinforced blades for parting and deep grooving with screw clamping

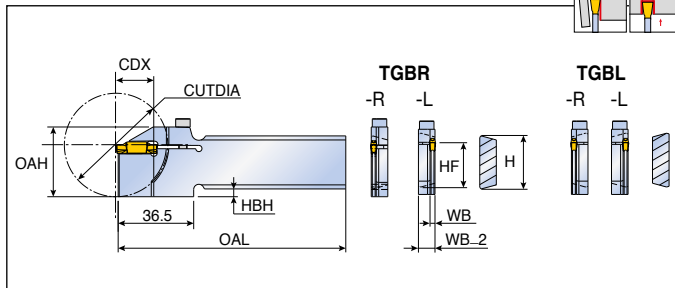

Designation	Insert seat size	Dimension (mm)									Block	Insert
		H	HF	OAL	OAH	WB	WB_2	HBH	CDX	CUTDIA		
TGBR 26-2-D50R ⁽¹⁾	2	26	21.4	110	33.7	1.8	8	3.6	18	50	TTBN/U..-26	TDC/J/V/UF
26-2-D50L ⁽²⁾	2	26	21.4	110	33.7	1.8	8	3.6	18	50	TTBN/U..-26	TSC/J
TGBL 26-2-D50R ⁽²⁾	2	26	21.4	110	33.7	1.8	8	3.6	18	50	TTBN/U..-26	TDCT/XU/XY/XT/T
26-2-D50L ⁽¹⁾	2	26	21.4	110	33.7	1.8	8	3.6	18	50	TTBN/U..-26	B129-B140
TGBR 26-3-D50R ⁽¹⁾	3	26	21.4	110	33.7	2.4	8	3.6	18	50	TTBN/U..-26	
26-3-D50L ⁽²⁾	3	26	21.4	110	33.7	2.4	8	3.6	18	50	TTBN/U..-26	
TGBL 26-3-D50R ⁽²⁾	3	26	21.4	110	33.7	2.4	8	3.6	18	50	TTBN/U..-26	
26-3-D50L ⁽¹⁾	3	26	21.4	110	33.7	2.4	8	3.6	18	50	TTBN/U..-26	
TGBR 32-2-D50R ⁽³⁾	2	32	24.9	120	33.7	1.8	8	-	18	50	TTBN/U..-32	
32-2-D50L ⁽²⁾	2	32	24.9	120	33.7	1.8	8	-	18	50	TTBN/U..-32	
TGBL 32-2-D50R ⁽²⁾	2	32	24.9	120	33.7	1.8	8	-	18	50	TTBN/U..-32	
32-2-D50L ⁽³⁾	2	32	24.9	120	33.7	1.8	8	-	18	50	TTBN/U..-32	
TGBR 32-3-D50R ⁽³⁾	3	32	24.9	120	33.7	2.4	8	-	18	50	TTBN/U..-32	
32-3-D50L ⁽²⁾	3	32	24.9	120	33.7	2.4	8	-	18	50	TTBN/U..-32	
TGBL 32-3-D50R ⁽²⁾	3	32	24.9	120	33.7	2.4	8	-	18	50	TTBN/U..-32	
32-3-D50L ⁽³⁾	3	32	24.9	120	33.7	2.4	8	-	18	50	TTBN/U..-32	B49-B50

- ▶ ⁽¹⁾ for Traub machines, model TNC 30, TNM 28, TNS 26/30/42/112, TNA 300, TNK 260
- ▶ ⁽²⁾ for Tornos Bechler, model Emco 2000/20, 2000/26
- ▶ ⁽³⁾ for Traub machines, model TNC 42/65, TNM 42/65, TNS 42/60/65, TNA 300/400

Spare parts

Designation	Screw	Wrench		
TGBR/L -DR/L	SH M4x0.7x16	L-W 3		

Blades for face grooving

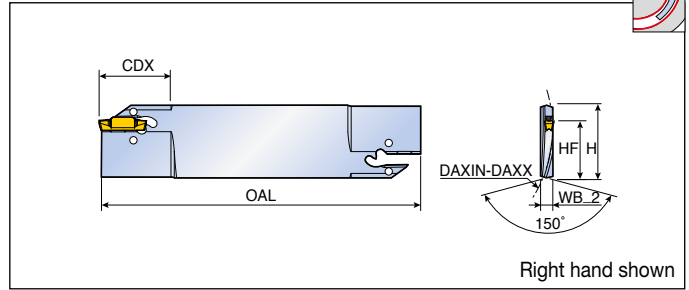

Designation	Insert seat size	Dimension (mm)								Block	Insert	
		H	HF	OAL	WB_2	CDX	DAXIN	DAXX				
TGBFR/L 32T20-40-60-3	3	32	24.9	150	5.2	20	40	60	TTBN/U...-32 B49-B50	TDC/J/T TDCT/XU/XT/XY TDFT TSC/J TDFU/TDV B129-B141		
32T20-54-80-3	3	32	24.9	150	5.2	20	54	80				
32T25-74-120-3	3	32	24.9	150	5.2	25	74	120				
32T25-114-180-3	3	32	24.9	150	5.2	25	114	180				
32T25-40-60-4	4	32	24.9	150	5.2	25	40	60				
32T25-50-80-4	4	32	24.9	150	5.2	25	50	80				
32T30-70-130-4	4	32	24.9	150	5.2	30	70	130				
32T30-120-200-4	4	32	24.9	150	5.2	30	120	200				
32T30-200-4	4	32	24.9	150	5.2	30	200	N.L.				
32T32-60-95-5	5	32	24.9	150	5.2	32	60	95				
32T35-85-140-5	5	32	24.9	150	5.2	35	85	140				
32T35-130-250-5	5	32	24.9	150	5.2	35	130	250				
32T35-250-5	5	32	24.9	150	5.2	35	250	N.L.				
32T32-80-180-6	6	32	24.9	150	5.2	32	80	180				
32T38-168-300-6	6	32	24.9	150	5.2	38	168	300				
32T38-300-6	6	32	24.9	150	5.2	38	300	N.L.				

- ▶ Please check insert min. dia for face grooving B83 page
- ▶ N.L.: No limit

Spare parts

Designation	Extractor			
	TGBFR/L	EDG 33B		

- ▶ Extractor should be ordered separately

Cartridges for external face grooving

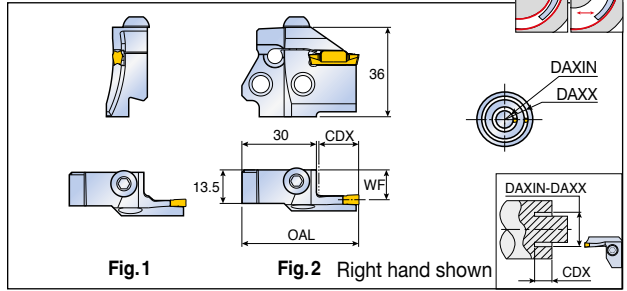

Designation	Insert seat size	Dimension (mm)					Fig.	Holder	Insert
		OAL	WF	CDX	DAXIN	DAXX			
TCAFR/L 3T10-29-40 RN	3	40	12.4	10	29	40	1	TCAHL/R	TDC/J/N/UF
3T12-40-55 RN	3	47	12.4	12	40	55	1	TCAHPR/L	TSC/J
3T12-55-75 RN	3	47	12.4	12	55	75	1	C...TCAHN	TDCT/XU/XY/XT/T
3T12-75-100 RN	3	47	12.4	12	75	100	1	C...TCAHPN	TDFT
3T12-100-140 RN	3	47	12.4	12	100	140	1	B57-B60	B129-B141
3T12-140-200 RN	3	47	12.4	12	140	200	1		
4T16-34-50 RN	4	47	12.0	16	34	50	2		
4T16-50-70 RN	4	47	12.0	16	50	70	2		
4T16-70-100 RN	4	47	12.0	16	70	100	2		
4T16-100-150 RN	4	47	12.0	16	100	150	2		
4T16-150-250 RN	4	47	12.0	16	150	250	2		
4T16-250 RN	4	47	12.0	16	250	N.L.	2		
5T20-55-80 RN	5	51.5	11.5	20	55	80	2		
5T20-80-120 RN	5	51.5	11.5	20	80	120	2		
5T20-120-180 RN	5	51.5	11.5	20	120	180	2		
5T20-180-300 RN	5	51.5	11.5	20	180	300	2		
5T20-300 RN	5	51.5	11.5	20	300	N.L.	2		
6T25-60-90 RN	6	56	11.0	25	60	90	2		
6T25-90-150 RN	6	56	11.0	25	90	150	2		
6T25-150-250 RN	6	56	11.0	25	150	250	2		
6T25-250-400 RN	6	56	11.0	25	250	400	2		
6T25-400 RN	6	56	11.0	25	400	N.L.	2		

- ▶ Please check insert min. dia for face grooving B83 page
- ▶ N.L.: No limit

Spare parts

Designation	Screw	Wrench		
TCAFR/L	BH M6x1x16	L-W 4		

TCAQR/L 20



Cartridges for external grooving

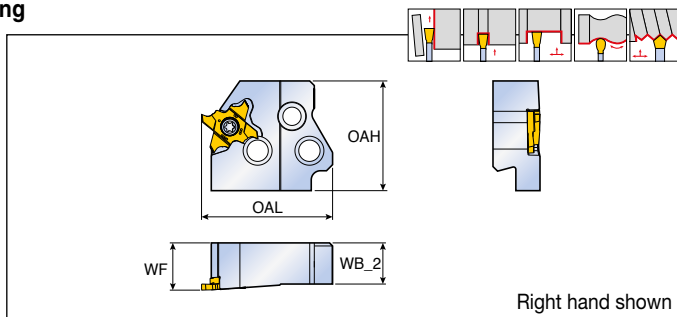

Designation	Dimension (mm)				Holder	Insert
	OAL	WF	WB_2	OAH		
TCAQR/L 20	43	15.5	13.5	36	TCAHR/L, TCAHPL/R C...TCAHN, C...TCAHPN B57-B60	TQ...20 B149-B150

► CDX: Refer to insert dimension

TCAQR/L 20-TB



Cartridges for external grooving with high pressure coolant

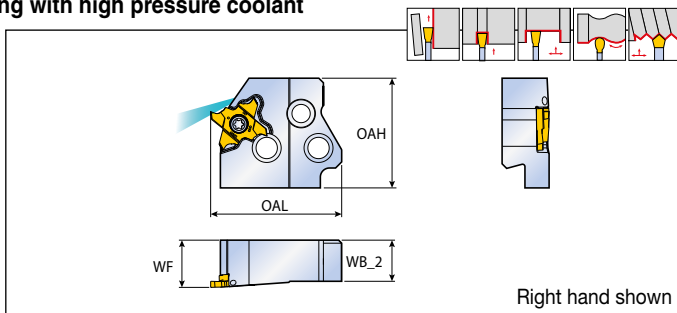

Designation	Dimension (mm)				Holder	Insert
	OAL	WF	WB_2	OAH		
TCAQR/L 20-TB	43	15.5	13.5	36	TCAHR/L-TB, TCAHPL/R-TB C...TCAHN-TB, C...TCAHPN-TB B57-B61	TQ...20 B149-B150

► CDX: Refer to insert dimension

Spare parts

Designation	Screw	Wrench		
TCAQR 20(-TB)	TS 40A100L	T-1508/5		
TCAQL 20(-TB)	TS 40A100	T-1508/5		

TCAQR/L 27/34



Cartridges for external grooving

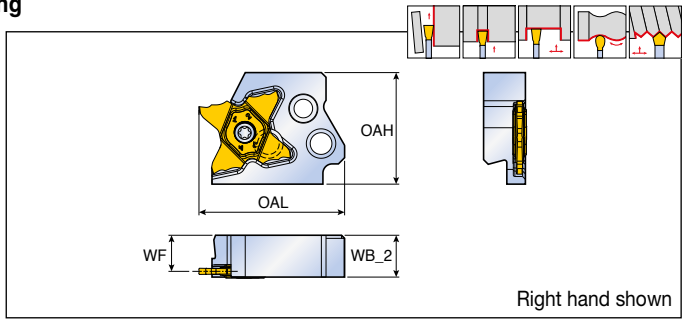

Right hand shown

Designation	Dimension (mm)				Holder	Insert
	OAL	WF	WB_2	OAH		
TCAQR/L 27	47	12.3	13.5	36	TCAHR/L, TCAHPL/R	TQ... 27
34	47	11.7	13.5	36	C...TCAHN, C...TCAHPN B57-B60	TQ... 34 B151-B161

► CDX: Refer to insert dimension

TCAQR/L 27-TB



Cartridges for external grooving with high pressure coolant

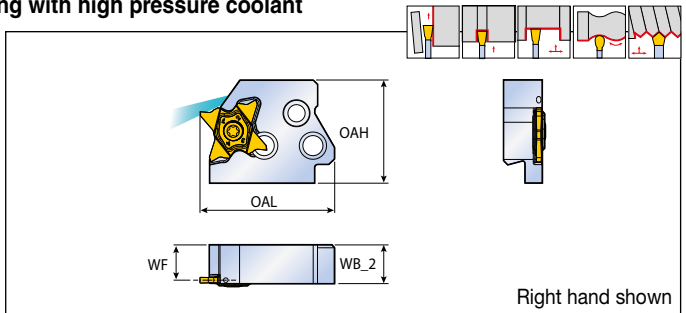

Right hand shown

Designation	Dimension (mm)				Holder	Insert
	OAL	WF	WB_2	OAH		
TCAQR/L 27-TB	47	12.3	13.5	36	TCAHR/L-TB, TCAHPL/R-TB C...TCAHN-TB, C...TCAHPN-TB B57-B61	TQ...27 B151-B159

► CDX: Refer to insert dimension

Spare parts

Designation	Screw	Wrench		
	TCAQR 27/34(-TB)	TS 50125IL	T 10/20	
TCAQL 27/34(-TB)	TS 50125I	T 10/20		

TCAHR/L

Parallel type holders for cartridge

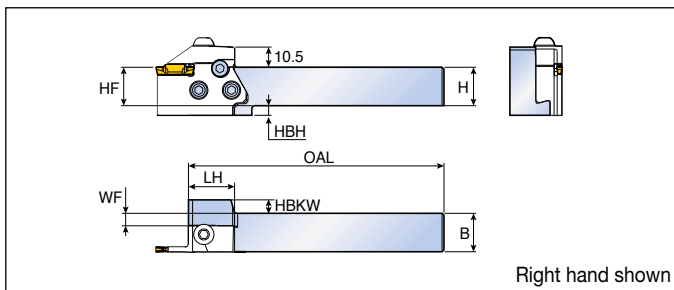

Designation	Dimension (mm)								Cartridge
	H	HF	B	OAL	WF	HBH	HBKW	LH	
TCAHR/L 2020	20	20	20	133	6.5	5	7	24	TCAER/L, TCAFL/R TCAQR/L B52-B56
2525	25	25	25	133	11.5	-	2	24	
3232	32	32	32	153	18.5	-	-	24	

► Cartridge should be ordered separately

TCAHR/L-TB

Parallel type holders for cartridge with high pressure coolant

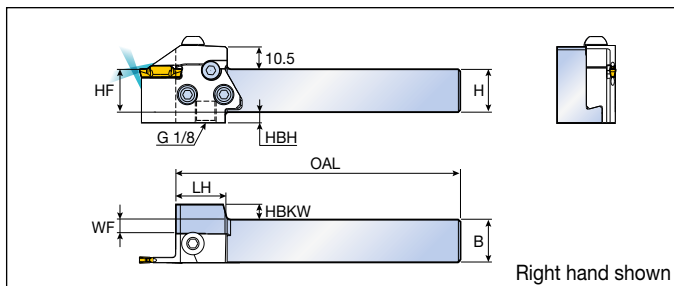

Designation	Dimension (mm)								Cartridge
	H	HF	B	OAL	WF	HBH	HBKW	LH	
TCAHR/L 2020-TB	20	20	20	133	6.5	5	7	24	TCAER/L-TB TCAQR/L-TB B53-B56
2525-TB	25	25	25	133	11.5	-	2	24	

► Cartridge should be ordered separately

► Please refer to B122 page for COOL-BURST accessories

Spare parts

Designation	Screw	Security Screw	Sealing Screw	O-Ring	Wrench	
TCAHR/L	TS 60190I	SH M5X0.8X16	-	-	L-W 4	-
TCAHR/L-TB	TS 60190I	SH M5X0.8X16	SS M4X0.7X4-NL	O-RING ID5X1T	L-W 4	L-W 2

TCAHPR/L

Perpendicular type holders for cartridge

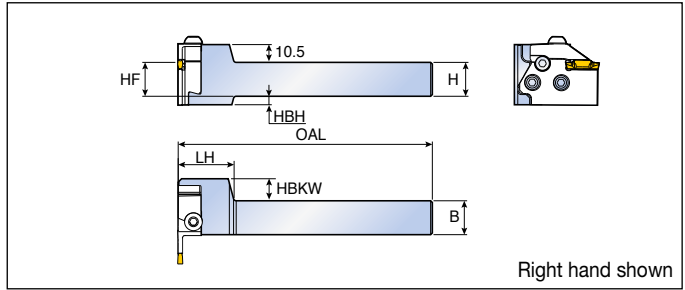

Designation	Dimension (mm)							Cartridge
	H	HF	B	OAL	HBH	HBKW	LH	
TCAHPR/L 2020	20	20	20	150	5	13	33	TCAEL/R, TCAFR/L TCAQL/R B52-B56
2525	25	25	25	150	-	8	33	
3232	32	32	32	170	-	1	33	

► Cartridge should be ordered separately

TCAHPR/L-TB

Perpendicular type holders for cartridge with high pressure coolant

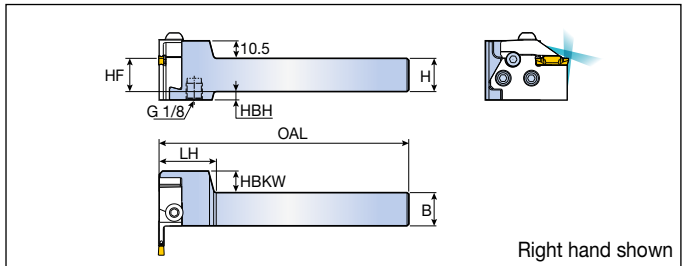

Designation	Dimension (mm)							Cartridge
	H	HF	B	OAL	HBH	HBKW	LH	
TCAHPR/L 2020-TB	20	20	20	150	5	13	33	TCAEL/R-TB TCAQL/R-TB B53-B56
2525-TB	25	25	25	150	-	8	33	

► Cartridge should be ordered separately

► Please refer to B122 page for COOL-BURST accessories

Spare parts

Designation	Screw	Security Screw	Sealing Screw	O-Ring	Wrench	
TCAHPR/L	TS 60190I	SH M5X0.8X16	-	-	L-W 4	-
TCAHPR/L-TB	TS 60190I	SH M5X0.8X16	SS M4X0.7X4-NL	O-RING 1D5X1T	L-W 4	L-W 2

C-TCAHN

Parallel type C-Adapters

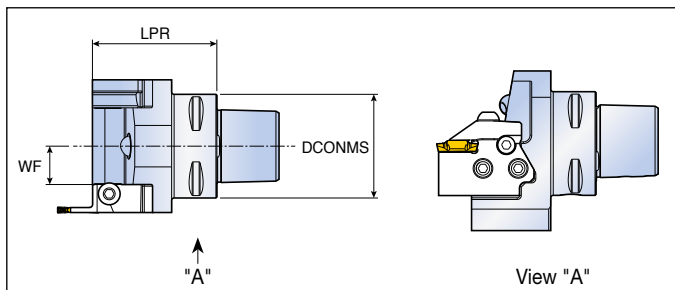

Designation	Dimension (mm)			Cartridge
	DCONMS	LPR	WF	
C4-TCAHN	40	60	18.7	TCAER/L, TCAFR/L
C5-TCAHN	50	60	18.5	TCAQR/L
C6-TCAHN	63	60	19	B52-B56

► Cartridge should be ordered separately

C-TCAHN-TB

Parallel type C-Adapters with high pressure coolant

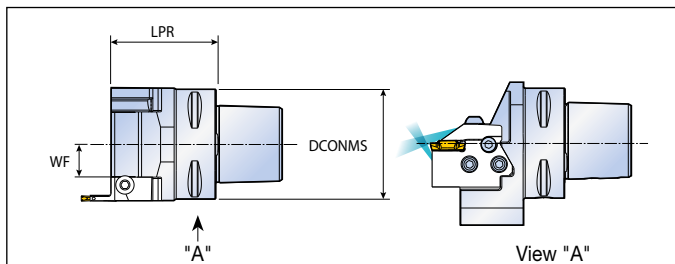

Designation	Dimension (mm)			Cartridge
	DCONMS	LPR	WF	
C4-TCAHN-TB	40	55	11.5	TCAER/L-TB
C5-TCAHN-TB	50	58	13.7	TCAQR/L-TB
C6-TCAHN-TB	63	60	18.7	B53-B56

► Cartridge should be ordered separately

Spare parts

Designation	Screw	Security Screw	Sealing Screw	Nozzle	O-Ring	Wrench
	C-TCAHN	TS 60190I	SH M5X0.8X16	-	NZ 125	-
C-TCAHN-TB	TS 60190I	SH M5X0.8X16	SS M4X0.7X4-NL	-	O-RING ID5X1T	L-W 4 / L-W 2

Parallel type with high pressure coolant

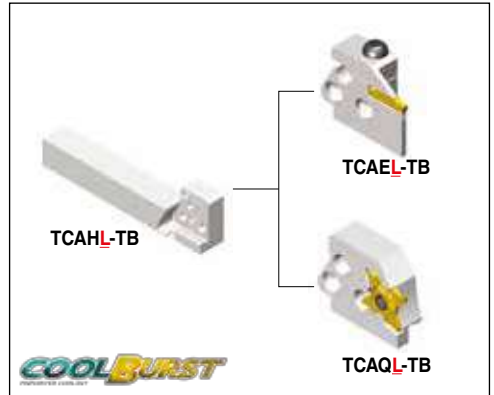
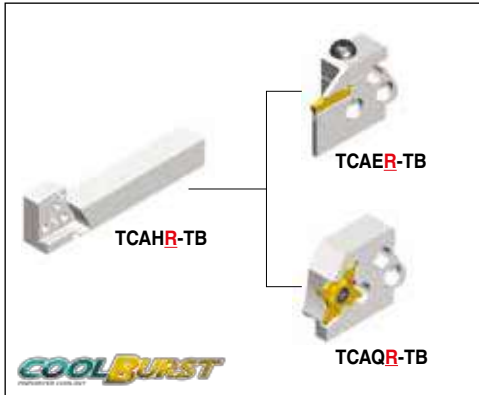

Perpendicular type with high pressure coolant

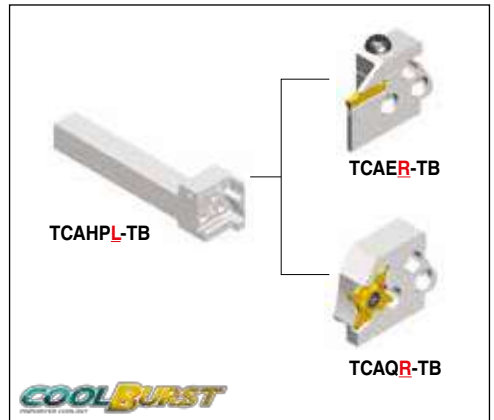
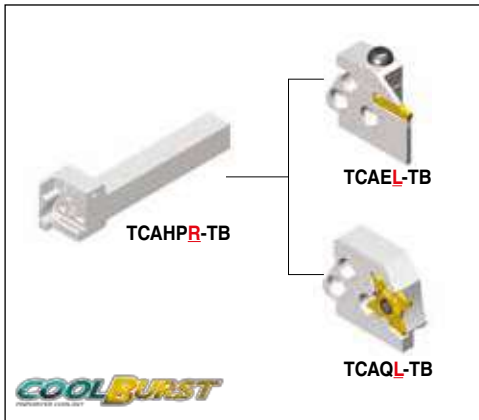

C-ADAPTER with high pressure coolant

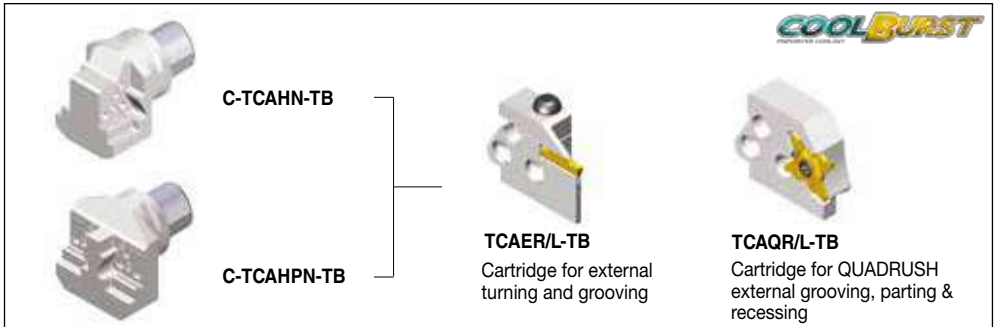

Cartridge and Holder Selection

Parallel type

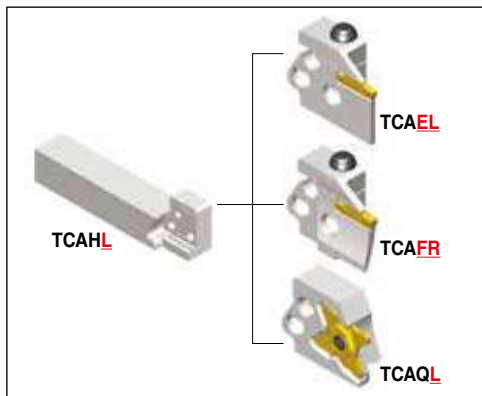
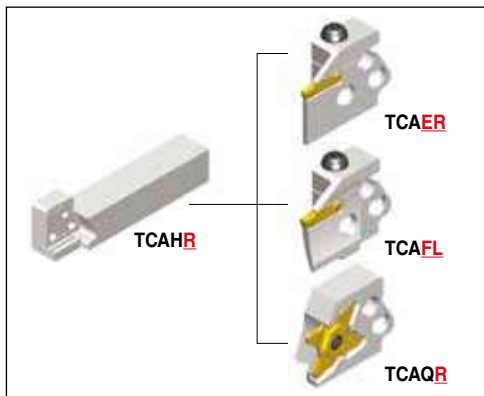

Perpendicular type

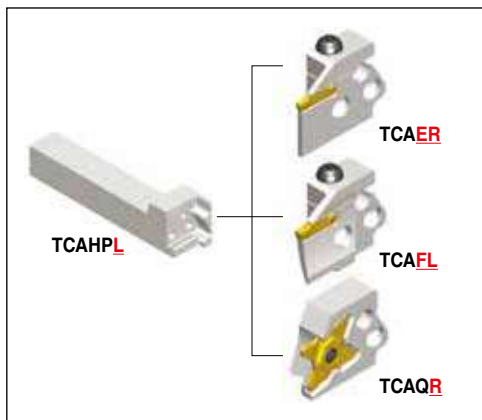
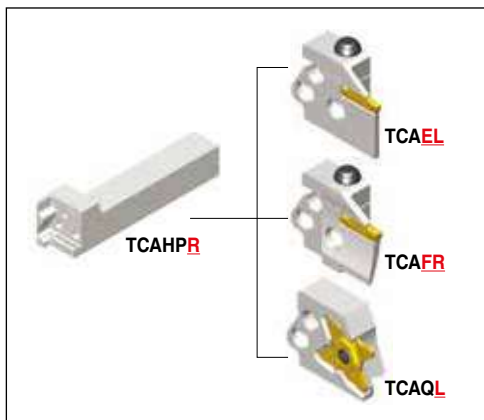

C-ADAPTER

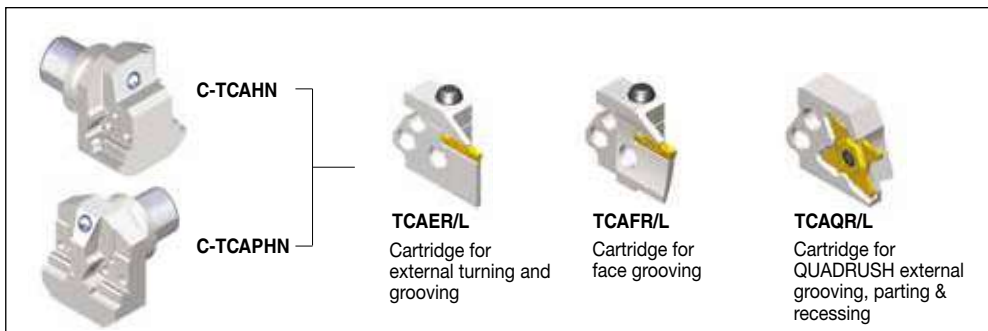

QE1 TTER



Modular heads for external turning and grooving

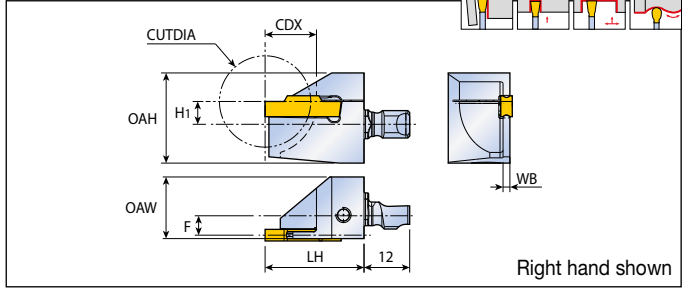

Designation	Insert seat size	Dimension (mm)									Shank	Insert
		OAH	LH	OAW	WB	CDX	CUTDIA	H1	F			
QE1 TTER 2-12-24	2	23.7	26.0	16.2	1.8	12.0	24.0	6.0	6.1	QE1 S12N-TB	TDC/J/V/UF	
2-16-32	2	23.7	26.0	16.2	1.8	16.0	32.0	6.0	6.1	QE1 S16R-TB	TSC/J	
3-12-24	3	23.7	26.0	16.2	2.4	12.0	24.0	6.0	5.8	B68	TDCT/XU/XY/XT/T	
3-16-32	3	23.7	26.0	16.2	2.4	16.0	32.0	6.0	5.8		B129-B140	

QE1 TTER-TB



Modular heads for external turning and grooving with high pressure coolant

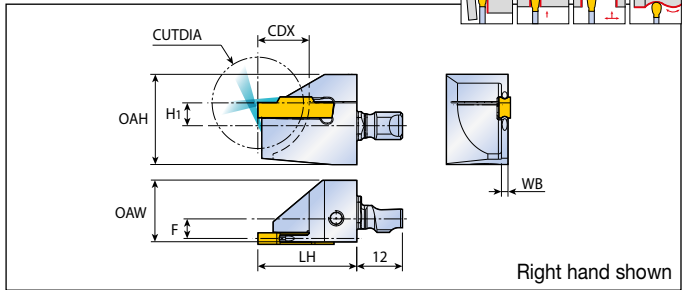

Designation	Insert seat size	Dimension (mm)									Shank	Insert
		OAH	LH	OAW	WB	CDX	CUTDIA	H1	F			
QE1 TTER 2-12-24-TB	2	23.7	26.0	16.2	1.8	12.0	24.0	6.0	6.1	QE1 S12N-TB	TDC/J/V/UF	
2-16-32-TB	2	23.7	26.0	16.2	1.8	16.0	32.0	6.0	6.1	QE1 S16R-TB	TSC/J	
3-12-24-TB	3	23.7	26.0	16.2	2.4	12.0	24.0	6.0	5.8	B68	TDCT/XU/XY/XT/T	
3-16-32-TB	3	23.7	26.0	16.2	2.4	16.0	32.0	6.0	5.8		B129-B140	

Spare parts

Designation	Screw	Wrench		
	QE1 TTER			
QE1 TTER-TB	SH M4X0.7X16	L-W 3		

QE1 TTEL



Modular heads for external turning and grooving

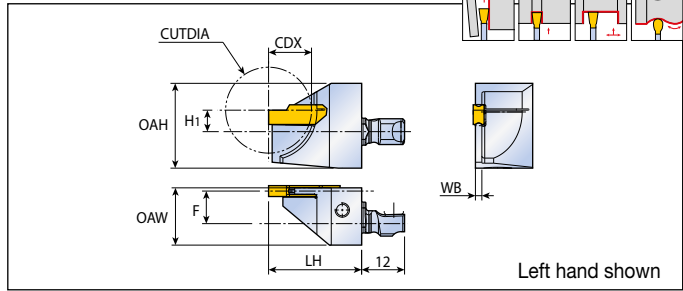

Designation	Insert seat size	Dimension (mm)								Shank	Insert
		OAH	LH	OAW	WB	CDX	CUTDIA	H1	F		
QE1 TTEL 2-12-24	2	23.7	26.0	16.0	1.8	12.0	24.0	6.0	8.1	QE1 S12N-TB	TDC/J/V/UF
2-16-32	2	23.7	26.0	16.0	1.8	16.0	32.0	6.0	8.1	QE1 S16R-TB	TSC/J
3-12-24	3	23.7	26.0	16.0	2.4	12.0	24.0	6.0	7.8	B68	TDCT/XU/XY/XT/T
3-16-32	3	23.7	26.0	16.0	2.4	16.0	32.0	6.0	7.8		B129-B140

QE1 TTEL-TB



Modular heads for external turning and grooving with high pressure coolant

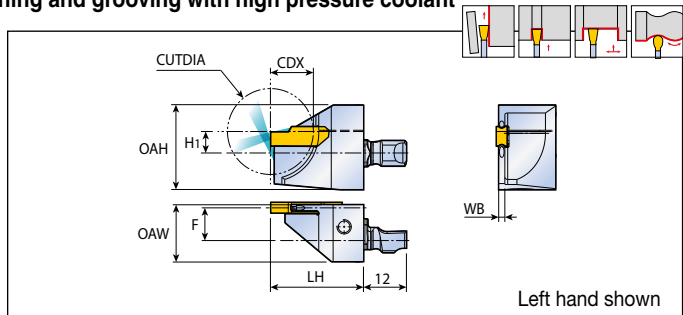

Designation	Insert seat size	Dimension (mm)								Shank	Insert
		OAH	LH	OAW	WB	CDX	CUTDIA	H1	F		
QE1 TTEL 2-12-24-TB	2	23.7	26.0	16.0	1.8	12.0	24.0	6.0	8.1	QE1 S12N-TB	TDC/J/V/UF
2-16-32-TB	2	23.7	26.0	16.0	1.8	16.0	32.0	6.0	8.1	QE1 S16R-TB	TSC/J
3-12-24-TB	3	23.7	26.0	16.0	2.4	12.0	24.0	6.0	7.8	B68	TDCT/XU/XY/XT/T
3-16-32-TB	3	23.7	26.0	16.0	2.4	16.0	32.0	6.0	7.8		B129-B140

Spare parts

Designation	Screw	Wrench		
	QE1 TTEL	SH M4X0.7X16	L-W 3	
QE1 TTEL-TB	SH M4X0.7X16	L-W 3		

QE1 TQHR/L

Modular head for parting and grooving on Swiss machines

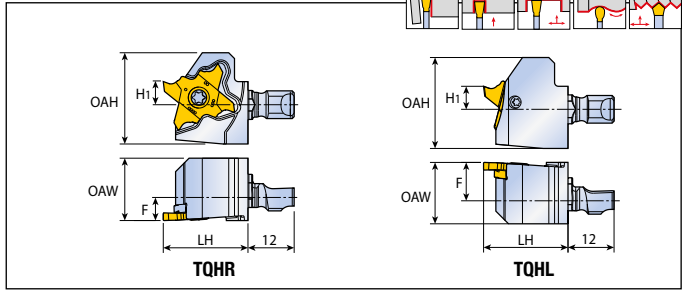

Designation	Dimension (mm)					Shank	Insert
	OAH	LH	OAW	H1	F		
QE1 TQHR 20	23.7	22.0	16.2	6.0	7.0	QE1 S12N-TB	TQ...20
TQHL 20	23.7	22.0	16.0	6.0	9.0	QE1 S16R-TB B68	B149-B150

► CDX: Refer to insert dimension

QE1 TQHR/L-TB

Modular head for parting and grooving with high-pressure coolant on Swiss machines

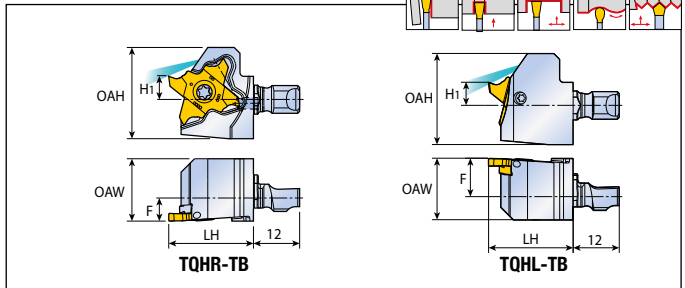

Designation	Dimension (mm)					Shank	Insert
	OAH	LH	OAW	H1	F		
QE1 TQHR 20-TB	23.7	22.0	16.2	6.0	7.0	QE1 S12N-TB	TQ...20
TQHL 20-TB	23.7	22.0	16.0	6.0	9.0	QE1 S16R-TB B68	B149-B150

► CDX: Refer to insert dimension

Spare parts

Designation	Screw	Wrench		
QE1 TQHR(-TB)	TS 40A100L	T-1508/5		
QE1 TQHL(-TB)	TS 40A100	T-1508/5		

QE1Y TQHR



Modular head for Y-axis parting and grooving on Swiss machines

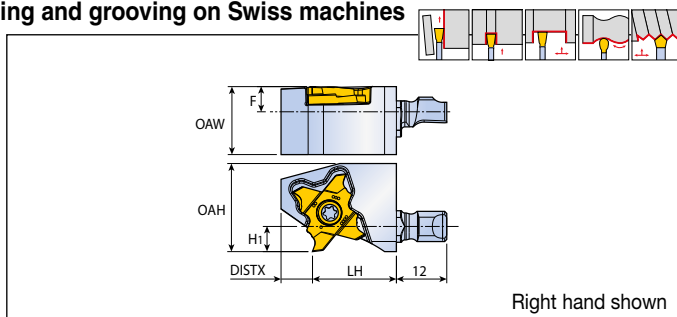

Designation	Dimensions (mm)						Shank	Insert
	OAH	LH	OAW	H1	F	DISTX		
QE1Y TQHR 20	21.0	20.0	16.2	6.0	7.0	7.5	QE1 S12N-TB QE1 S16L-TB B68	TQ... 20 B149-B150

► CDX: Refer to insert dimension

QE1Y TQHR-TB



Modular head for Y-axis parting and grooving with high-pressure coolant on Swiss machines

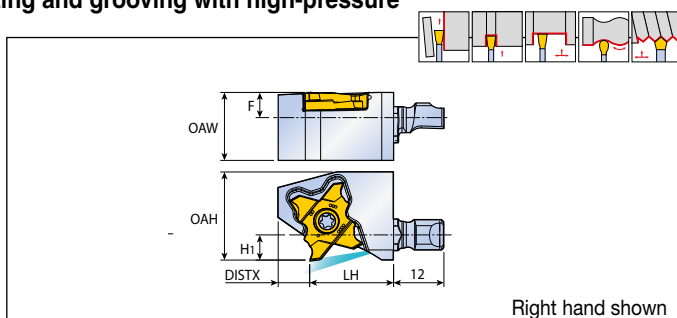

Designation	Dimensions (mm)						Shank	Insert
	OAH	ALH	OAW	H1	F	DISTX		
QE1Y TQHR 20-TB	21.0	20.0	16.2	6.0	7.0	7.5	QE1 S12N-TB QE1 S16L-TB B68	TQ... 20 B149-B150

► CDX: Refer to insert dimension

Spare parts

Designation	Screw	Wrench		
QE1Y TQHR 20(-TB)	TS 40A100L	T-1508/5		

QE1 S12N-TB



High pressure coolant shanks for WIN-SWISS modular head

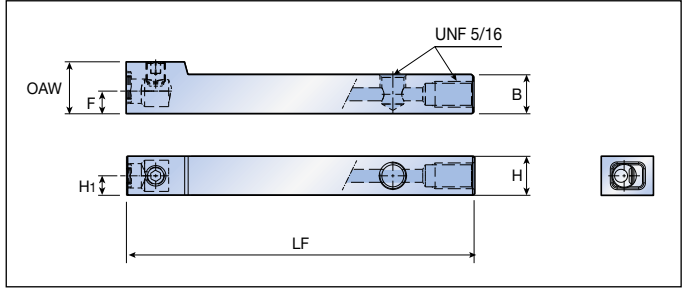

Designation	Dimension (mm)						Modular head
	H	H1	B	LF	OAW	F	
QE1 S12N-TB	12	6	12	107	16	7	QE1...R/L(-TB) B64-B67

► Please refer to B122 page for COOL-BURST accessories

QE1 S16R/L-TB



High pressure coolant shanks for WIN-SWISS modular head

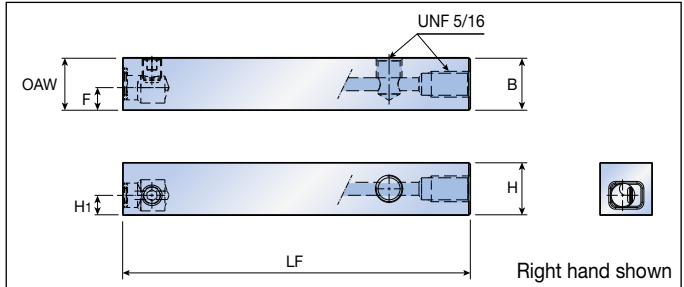

Designation	Dimension (mm)						Modular head
	H	H1	B	LF	OAW	F	
QE1 S16R/L-TB	16	6	16	107	16	7	QE1...R/L(-TB) B64-B67

► Please refer to B122 page for COOL-BURST accessories

Spare parts

Designation	Screw	Plug	Wrench	
QE1 ...-TB	SS M6F-7	PLG 5/16 UNF	L-W 3	L-W 5/32

QE1 FIX-20100

Insert replacement fixture

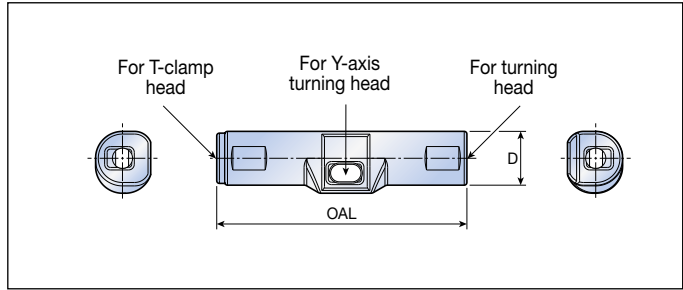

Designation	Dimensions (mm)	
	OAL	D
QE1 FIX-20100	93.0	20.0

► Fixture ordered seperately

Insert replacement

► Due to the WIN-SWISS' small head sizes, replacing the inserts could be difficult. Please use the fixture to facilitate insert replacement.

► Y-axis turning head

► T-clamp head

► Turning head



Anti-vibration shanks for boring

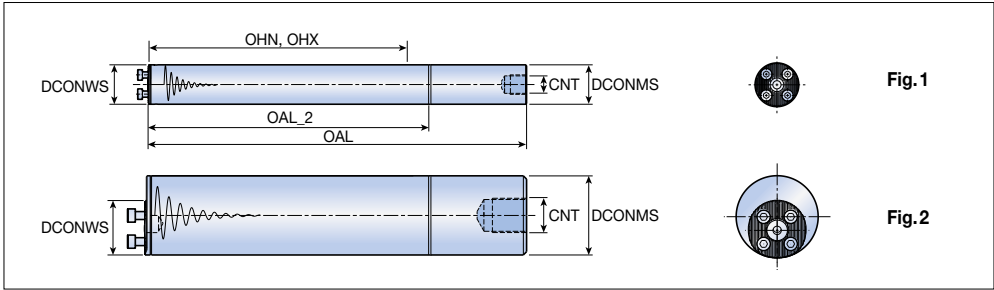

Designation	Dimension (mm)							Coolant hole	Fig.
	DCONMS	DCONWS	OAL	OAL_2	OHN	OHX	CNT		
QS25A-7D	25	25	257.5	155	88	155	G 1/4	●	1
QS25A-10D	25	25	332.5	255	155	230	G 1/4	●	1
QS25E-12D⁽¹⁾	25	25	380.0	-	230	280	G 1/8	●	1
QS25E-14D⁽¹⁾	25	25	430.0	-	280	330	G 1/8	●	1
QS32A-7D	32	32	323.0	190	120	192	G 3/8	●	1
QS32A-10D	32	32	419.0	320	192	288	G 3/8	●	1
QS32E-12D⁽¹⁾	32	32	480.0	-	288	352	G 1/4	●	1
QS32E-14D⁽¹⁾	32	32	544.0	-	352	416	G 1/4	●	1
QS40A-7D	40	40	411.0	240	128	251	G 1/2	●	1
QS40A-10D	40	40	531.0	410	248	368	G 1/2	●	1
QS40E-12D⁽¹⁾	40	40	608.0	-	368	448	G 3/8	●	1
QS40E-14D⁽¹⁾	40	40	688.0	-	448	528	G 3/8	●	1
QS50A-7D	50	40	523.0	305	168	318	G 1/2	●	2
QS50A-10D	50	40	673.0	520	318	468	G 1/2	●	2
QS50E-12D⁽¹⁾	50	40	768.0	-	468	568	G 1/2	●	2
QS50E-14D⁽¹⁾	50	40	868.0	-	568	668	G 1/2	●	2
QS60A-7D	60	40	633.0	380	208	388	G 3/4	●	2
QS60A-10D	60	40	813.0	630	388	568	G 3/4	●	2
QS60E-12D⁽¹⁾	60	40	920.0	-	588	688	G 3/4	●	2
QS60E-14D⁽¹⁾	60	40	1040.0	-	688	808	G 3/4	●	2

- ▶ ⁽¹⁾ Carbide shank
- ▶ OHN: Minimum overhang
- ▶ OHX: Maximum overhang
- ▶ OAL_2: Minimum length after shortening(only steel bar can be shortened)
- ▶ Refer to A221 page for C-Adapter connection

Spare parts

Designation	Screw	Wrench		
QS16	SH M3x0.5X10	L-W 2.5		
QS20	SH M3.5x0.6X10	L-W 2.5		
QS25	SH M4x0.7X12	L-W 3		
QS32	SH M5x0.8X12	L-W 4		
QS40/50/60	SH M6x1X16	L-W 5		

Machining depth for diameter of workpiece

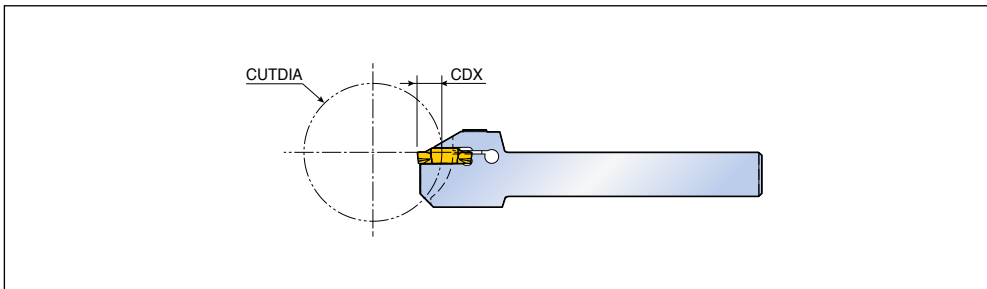

Designation		CDX													
		1	2	3	4	5	6	7	8	9	10	11	12	13	
TTER/L 1010-1.4T15-D40	CUTDIA					N.L.						269	120	79	
1212-1.4T15-D40						N.L.						269	120	79	
1616-1.4T20-D45						N.L.									432
2020-1.4T20-D45						N.L.									432
1010-2T15-D40						N.L.						269	120	79	
1212-2T15-D40						N.L.						269	120	79	
1616-2T20-D45						N.L.									432
2020-2T20-D45						N.L.									432
2525-2T20-D45						N.L.				1468	339	193	136	106	
1212-3T15-D40						N.L.						269	120	79	
1616-3T20-D45						N.L.									432
2020-3T20-D45						N.L.									432
2525-3T20-D45						N.L.				1468	339	193	136	106	
2525-3T25-D60						N.L.									

► N.L.: No limit

Designation		CDX												
		14	15	16	17	18	19	20	21	22	23	24	25	
TTER/L 1010-1.4T15-D40	CUTDIA	59	40											
1212-1.4T15-D40		59	40											
1616-1.4T20-D45		193	125	94	76	64	57	45						
2020-1.4T20-D45		193	125	94	76	64	57	45						
1010-2T15-D40		59	40											
1212-2T15-D40		59	40											
1616-2T20-D45		193	125	94	76	64	57	45						
2020-2T20-D45		193	125	94	76	64	57	45						
2525-2T20-D45		87	75	67	60	56	52	45						
1212-3T15-D40		59	40											
1616-3T20-D45		193	125	94	76	64	57	45						
2020-3T20-D45		193	125	94	76	64	57	45						
2525-3T20-D45		87	75	67	60	56	52	45						
2525-3T25-D60					1810	418	237	167	130	107	91	81	73	60

Holders for external turning and grooving

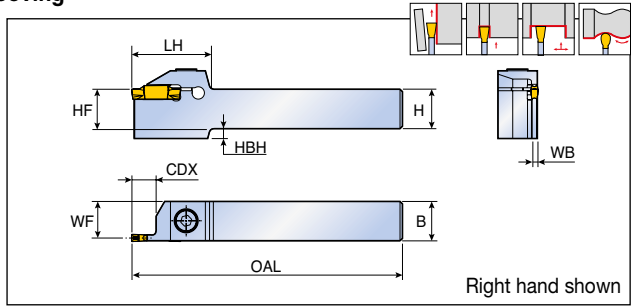
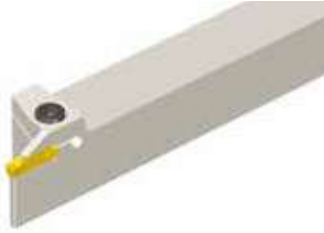

Designation	Insert seat size	Dimension (mm)								Insert
		H(HF)	B	OAL	LH	WF	WB	HBH	CDX	
TTER/L 1616-2T08	2	16	16	110	30.0	15.1	1.8	4	8	TDC/J/M/UF TSC/J TDCT/XU/XY/XT/T B129-B140
2020-2T08	2	20	20	125	30.0	19.1	1.8	-	8	
2525-2T08	2	25	25	150	30.0	24.1	1.8	-	8	
1616-2	2	16	16	110	32.0	15.1	1.8	4	12	
2020-2	2	20	20	125	32.0	19.1	1.8	-	12	
2525-2	2	25	25	150	32.0	24.1	1.8	-	12	
1616-2T17	2	16	16	110	37.0	15.1	1.8	4	17	
2020-2T17	2	20	20	125	37.0	19.1	1.8	-	17	
2525-2T17	2	25	25	150	37.0	24.1	1.8	-	17	
TTER/L 1616-3T09	3	16	16	110	30.0	14.8	2.4	4	9	
2020-3T09	3	20	20	125	30.0	18.8	2.4	-	9	
2525-3T09	3	25	25	150	30.0	23.8	2.4	-	9	
1616-3	3	16	16	110	32.0	14.8	2.4	4	12	
2020-3	3	20	20	125	32.0	18.8	2.4	-	12	
2525-3	3	25	25	150	32.0	23.8	2.4	-	12	
1616-3T20	3	16	16	110	38.5	14.8	2.4	-	20	
2020-3T20	3	20	20	125	38.5	18.8	2.4	-	20	
2525-3T20	3	25	25	150	38.5	23.8	2.4	-	20	
2525-3T25	3	25	25	150	44.5	23.8	2.4	-	25	
3232-3T20	3	32	32	170	38.5	30.8	2.4	-	20	
TTER/L 1616-4T10	4	16	16	110	32.0	14.5	3.0	4	10	
2020-4T10	4	20	20	125	32.0	18.5	3.0	-	10	
2525-4T10	4	25	25	150	32.0	23.5	3.0	-	10	
1616-4	4	16	16	110	33.0	14.5	3.0	4	15	
2020-4	4	20	20	125	33.0	18.5	3.0	-	15	
2525-4	4	25	25	150	33.0	23.5	3.0	-	15	
1616-4T25	4	16	16	110	45.0	14.5	3.0	-	25	
2020-4T25	4	20	20	125	45.0	18.5	3.0	-	25	
2525-4T25	4	25	25	150	45.0	23.5	3.0	-	25	
2525-4T30	4	25	25	150	51.0	23.5	3.0	-	30	
3232-4T25	4	32	32	170	45.0	30.5	3.0	-	25	
TTER/L 2020-5T12	5	20	20	125	35.0	18.1	3.9	-	12	
2525-5T12	5	25	25	150	35.0	23.1	3.9	-	12	
2020-5	5	20	20	125	37.0	18.1	3.9	-	20	
2525-5	5	25	25	150	37.0	23.1	3.9	-	20	
2525-5T32	5	25	25	150	56.0	23.0	3.9	-	32	
3232-5T20	5	32	32	170	39.0	30.0	3.9	-	20	
3232-5T32	5	32	32	170	56.0	30.0	3.9	-	32	

Holders for external turning and grooving

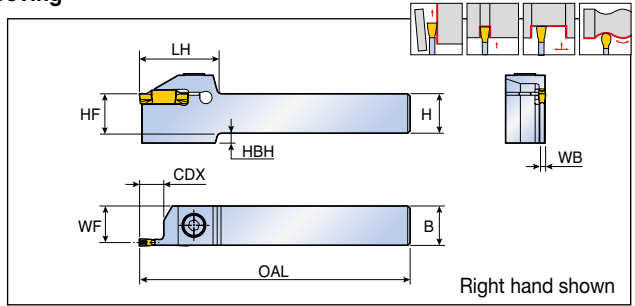

Designation	Insert seat size	Dimension (mm)								Insert
		H(HF)	B	OAL	LH	WF	WB	HBH	CDX	
TTER/L 2020-6T12	6	20	20	125	37	17.6	4.9	-	12	TDC/J/V/UF
2525-6T12	6	25	25	150	37	22.6	4.9	7	12	TSC/J
2020-6	6	20	20	125	41	17.6	4.9	-	20	TDCT/XU/XY/XT/T
2525-6	6	25	25	150	41	22.6	4.9	7	20	B129-B140
2525-6T32	6	25	25	150	56	22.5	4.9	7	32	
3232-6T20	6	32	32	170	41	29.5	4.9	-	20	
3232-6T25	6	32	32	170	46	29.5	4.9	-	25	
3232-6T32	6	32	32	170	56	29.5	4.9	-	32	
TTER/L 2525-8T16	8	25	25	150	40	22.1	5.9	7	16	
2525-8	8	25	25	150	47	22.1	5.9	7	25	
3232-8	8	32	32	170	47	29.1	5.9	-	25	
2525-8T36	8	25	25	150	60	22.1	5.9	7	36	
3232-8T36	8	32	32	170	60	29.1	5.9	-	36	
TTER/L 2525-10T25	10	25	25	150	50	21.1	7.9	7	25	
3232-10T25	10	32	32	170	50	28.1	7.9	-	25	
4040-10T25	10	40	40	200	50	36.1	7.9	-	25	

Spare parts

Designation	Screw	Wrench		
TTER/L 1616-2/3	SH M5x0.8x16	L-W 4		
TTER/L 2020-2/3	SH M5x0.8x20	L-W 4		
TTER/L 2525-2/3	SH M5x0.8x25	L-W 4		
TTER/L 3232-3	SH M5x0.8x25	L-W 4		
TTER/L 1616-4/5	SH M6x1x16	L-W 5		
TTER/L 2020-4/5	SH M6x1x20	L-W 5		
TTER/L 2525-4/5	SH M6x1x25	L-W 5		
TTER/L 3232-4/5	SH M6x1x25	L-W 5		
TTER/L 2020-6	SH M8x1.25x20	L-W 6		
TTER/L 2525-6/8	SH M8x1.25x25	L-W 6		
TTER/L 3232-6/8/10	SH M8x1.25x25	L-W 6		
TTER/L 4040-10	SH M8x1.25x25	L-W 6		

Holders for external turning and grooving

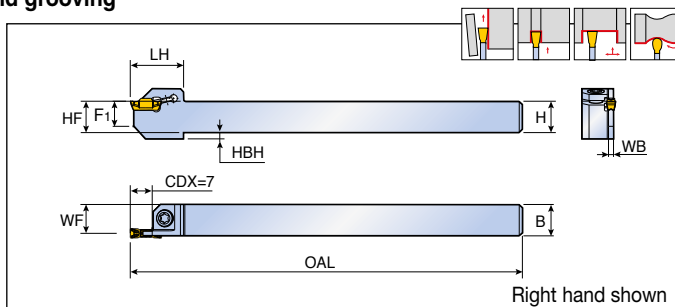

Designation	Insert seat size	Dimension (mm)								Insert
		H(HF)	B	OAL	LH	WF	WB	F1	HBH	
TTSER/L 1010-2T7	2	10	10	125	17	9.2	1.6	8	2	TDIM/TDIP B142, B143
1212-2T7	2	12	12	125	17	11.2	1.6	8	-	
1616-2T7	2	16	16	125	20	15.2	1.6	11	-	
2020-2T7	2	20	20	125	20	19.2	1.6	14	-	
2525-2T7	2	25	25	125	20	24.2	1.6	18	-	
1010-3T7	3	10	10	125	17	8.8	2.4	8	2	
1212-3T7	3	12	12	125	17	10.8	2.4	8	-	
1616-3T7	3	16	16	125	20	14.8	2.4	11	-	
2020-3T7	3	20	20	125	20	18.8	2.4	14	-	
2525-3T7	3	25	25	125	20	23.8	2.4	18	-	

Spare parts

Designation	Screw	Wrench		
TTSER/L	TS 400971	T 15		

Holders for deep face grooving

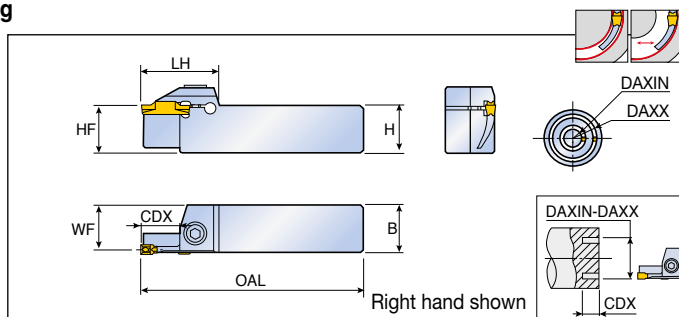

Designation	Insert seat size	Dimension (mm)									Insert
		H(HF)	B	OAL	LH	WF	CDX	DAXIN	DAXX		
TTFR/L 25-30-3	3	25	25	150	32	24.0	10	24	35	TDC/J/V/UF	
25-35-3	3	25	25	150	32	24.0	10	29	40	TSC/J	
25-40-3	3	25	25	150	32	24.0	10	34	50	TDCT/XU/XY/XT/T	
25-50-3	3	25	25	150	32	24.0	15	44	60	TDFT	
25-60-3	3	25	25	150	32	24.0	15	54	85	B129-B141	
25-30-4	4	25	25	150	33	23.6	12	22	40		
25-40-4	4	25	25	150	33	23.6	15	32	50		
25-50-4	4	25	25	150	33	23.6	15	42	60		
25-60-4	4	25	25	150	33	23.6	15	52	85		
25-60-5	5	25	25	150	41	23.1	20	50	80		
25-80-5	5	25	25	150	41	23.1	20	70	110		
25-110-5	5	25	25	150	41	23.1	20	110	150		
25-150-5	5	25	25	150	41	23.1	20	140	200		
25-60-6	6	25	25	150	41	22.6	20	48	85		
25-85-6	6	25	25	150	41	22.6	20	73	150		
25-150-6	6	25	25	150	41	22.6	20	138	250		
25-250-6	6	25	25	150	41	22.6	20	250	N.L.		

- ▶ Please check insert min. dia for face grooving [B83](#) page
- ▶ N.L.: No limit

Spare parts

Designation	Screw	Wrench		
TTFR/L...-3	SH M5x0.8x25	L-W 4		
TTFR/L...-4	SH M6x1x25	L-W 5		
TTFR/L...-5	SH M8X1.25X25	L-W 5		
TTFR/L...-6	SH M8X1.25X25	L-W 5		

Holders for deep face grooving along shaft

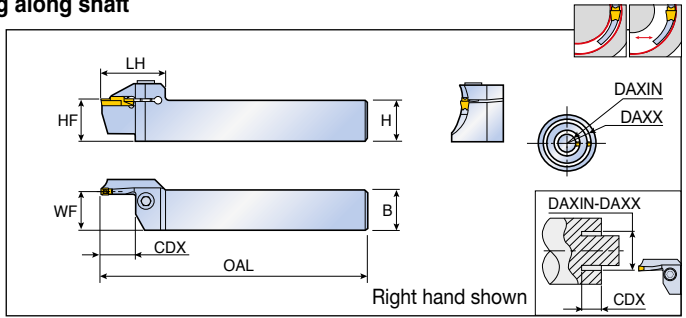

Designation	Insert seat size	Dimension (mm)								Insert
		H(HF)	B	OAL	LH	WF	CDX	DAXIN	DAXX	
TTFR/L 20-21-30-3T10 RN	3	20	20	140	31	19.0	10	21	30	TDC/J/W/UF
20-24-35-3T10 RN	3	20	20	140	31	19.0	10	24	35	TSC/J
20-29-40-3T10 RN	3	20	20	140	31	19.0	10	29	40	TDCT/XU/XY/XT/T
20-34-50-3T10 RN	3	20	20	140	31	19.0	10	34	50	TDFT
20-44-70-3T15 RN	3	20	20	140	35	19.0	15	44	70	B129-B141
20-64-100-3T15 RN	3	20	20	140	35	19.0	15	64	100	
25-30-3 RN	3	25	25	150	35	24.0	10	24	35	
25-35-3 RN	3	25	25	150	35	24.0	10	29	40	
25-40-3 RN	3	25	25	150	35	24.0	10	34	50	
25-50-3 RN	3	25	25	150	35	24.0	15	44	70	
25-70-3 RN	3	25	25	150	35	24.0	15	64	100	
20-19-30-4T10 RN	4	20	20	140	31	18.6	10	19	30	
20-22-36-4T10 RN	4	20	20	140	31	18.6	10	22	36	
20-28-42-4T16 RN	4	20	20	140	36	18.6	16	28	42	
20-34-50-4T16 RN	4	20	20	140	36	18.6	16	34	50	
20-42-70-4T16 RN	4	20	20	140	36	18.6	16	42	70	
20-62-120-4T16 RN	4	20	20	140	36	18.6	16	62	120	
20-112-200-4T16 RN	4	20	20	140	36	18.6	16	112	200	
25-30-4 RN	4	25	25	150	35	23.6	10	22	36	
25-36-4 RN	4	25	25	150	39	23.6	20	28	42	
25-42-4 RN	4	25	25	150	39	23.6	20	34	50	
25-50-4 RN	4	25	25	150	39	23.6	20	42	70	
25-70-4 RN	4	25	25	150	39	23.6	20	62	120	
25-120-4 RN	4	25	25	150	39	23.6	20	112	200	
25-200-4 RN	4	25	25	150	39	23.6	20	200	N.L.	
25-60-5T15 RN	5	25	25	150	41	23.1	15	50	80	
25-60-5 RN	5	25	25	150	49	23.1	25	50	80	
25-80-5T15 RN	5	25	25	150	41	23.1	15	70	110	
25-80-5 RN	5	25	25	150	49	23.1	25	70	110	
25-110-5 RN	5	25	25	150	49	23.1	25	100	150	
25-150-5 RN	5	25	25	150	49	23.1	25	140	200	
25-200-5 RN	5	25	25	150	49	23.1	25	200	N.L.	

▶ Please check insert min. dia for face grooving B83 page
 ▶ N.L.: No limit

TTFR/L-RN

Holders for deep face grooving along shaft

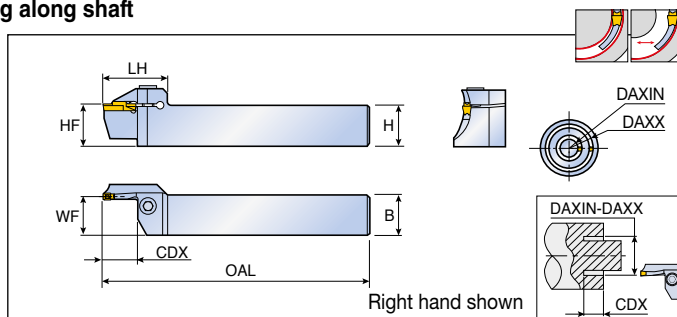

Designation	Insert seat size	Dimension (mm)								Insert
		H(HF)	B	OAL	LH	WF	CDX	DAXIN	DAXX	
TTFR/L 25-60-6 RN	6	25	25	150	49	22.6	25	48	70	TDC/J/V/UF
25-70-6 RN	6	25	25	150	49	22.6	25	58	100	TSC/J
25-100-6 RN	6	25	25	150	49	22.6	25	88	180	TDCT/XU/XY/XT/T
25-180-6 RN	6	25	25	150	49	22.6	25	168	400	TDFT
25-400-6 RN	6	25	25	150	49	22.6	25	400	N.L.	B129-B141

- ▶ Please check insert min. dia for face grooving B83 page
- ▶ N.L.: No limit

Insert initial min.Dia (Dmin) for face grooving

Machining	Insert	Size (mm)	Min. dia. (mm)	Insert	Size (mm)	Min. dia. (mm)
Facing Min. dia. of face machining	TDJ/C TDUF / TDV	3	54	TDT RU TDT RS	3	41
		4	34		4	36
		5	49		5	54
		6	46		6	54
	TDT	3	44	TDCT TDXU TDXT TDXY TDFT	3	18
		4	42		4	18
		5	50		5	20
		6	48		6	18

Spare parts

Designation	Screw	Wrench		
TTFR/L 20...RN	SH M6x1x20	L-W 5		
TTFR/L 25...3/4 RN	SH M6x1x25	L-W 5		
TTFR/L 25...5/6 RN	SH M8x1.25x25	L-W 6		

Perpendicular type holders for deep face grooving

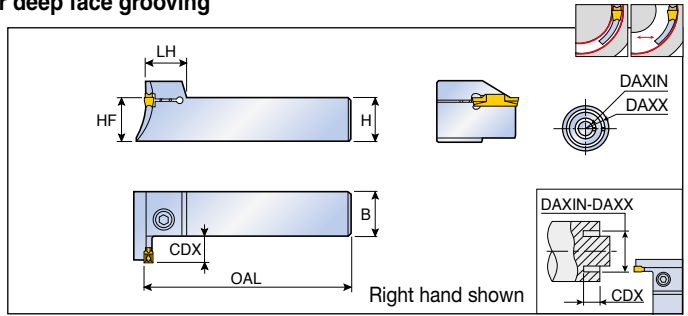

Designation	Insert seat size	Dimension (mm)							Insert
		H(HF)	B	OAL	LH	CDX	DAXIN	DAXX	
TTFPR/L 25-30-3	3	25	25	150	18.0	10	24	35	TDC/J/V/UF
25-35-3	3	25	25	150	18.0	10	29	40	TSC/J
25-40-3	3	25	25	150	18.0	10	34	50	TDCT/XU/XY/XT/T
25-50-3	3	25	25	150	18.0	15	44	60	TDFT
25-60-3	3	25	25	150	18.0	15	54	85	B129-B141
25-30-4	4	25	25	150	18.5	12	22	40	
25-40-4	4	25	25	150	18.5	15	32	50	
25-50-4	4	25	25	150	18.5	15	42	60	
25-60-4	4	25	25	150	18.5	15	52	85	
25-60-5	5	25	25	150	22.0	20	50	80	
25-80-5	5	25	25	150	22.0	20	70	110	
25-110-5	5	25	25	150	22.0	20	100	150	
25-150-5	5	25	25	150	22.0	20	140	200	
25-200-5	5	25	25	150	22.0	20	200	N.L.	
25-60-6	6	25	25	150	22.0	20	48	85	
25-85-6	6	25	25	150	22.0	20	73	150	
25-150-6	6	25	25	150	22.0	20	138	250	
25-250-6	6	25	25	150	22.0	20	250	N.L.	

- ▶ Please check insert min. dia for face grooving B83 page
- ▶ N.L.: No limit

Spare parts

Designation	Screw	Wrench		
TTFPR/L...-3	SH M5x0.8x25	L-W 4		
TTFPR/L...-4	SH M6x1x25	L-W 5		
TTFPR/L...-5	SH M8x1.25x25	L-W 6		
TTFPR/L...-6	SH M8x1.25x25	L-W 6		

Internal boring bars for shallow face grooving

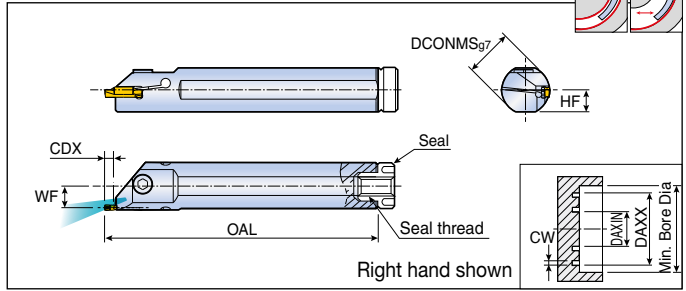

Designation	Insert seat size	Dimension (mm)					Insert
		DCONMS	OAL	WF	HF	CDX	
TGIFR/L 25-4C-T5.5	3, 4	25	200	11.3	11.5	5.5	TDC/J/V/UF
32-4C-T5.5	3, 4	32	250	14.8	15.0	5.5	TSC/J
25-6C-T5.5	5, 6	25	200	10.3	11.5	5.5	TDCT/XU/XY/XT/T
32-6C-T5.5	5, 6	32	250	13.8	15.0	5.5	TDFT
							B129-B141

► Please check insert min. dia for face grooving [B83](#) page

CW	Min. Bore Dia		DAXIN				DAXX
	DCONMS ϕ 25	DCONMS ϕ 32	TDC/J/UF/V	TDFT / TD XU / TDXT	TDT	TDT-RU/RS	
3	26.3	33.3	54	18	44	41	No limit
4	26.8	33.8	34	18	42	36	
5	26.3	33.3	49	20	50	54	
6	26.8	33.8	46	18	48	54	

TGIFR/L Application

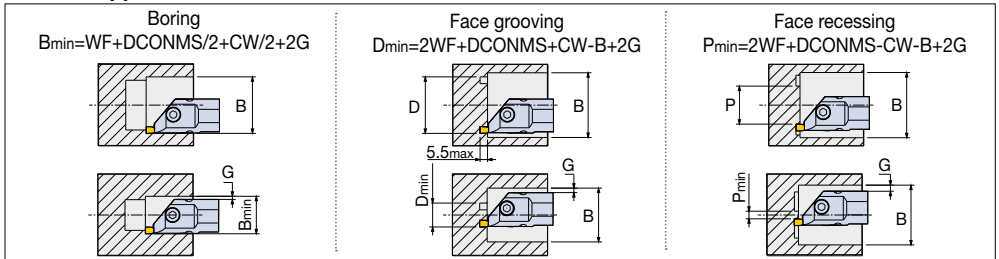

Spare parts

Designation	Screw	Wrench	Seal
TGIFR/L 25	SH M6x1x16	L-W 5	PL 25 (R1/8)
TGIFR/L 32	SH M6x1x16	L-W 5	PL 32 (R1/8)

Internal boring bars for turning and grooving

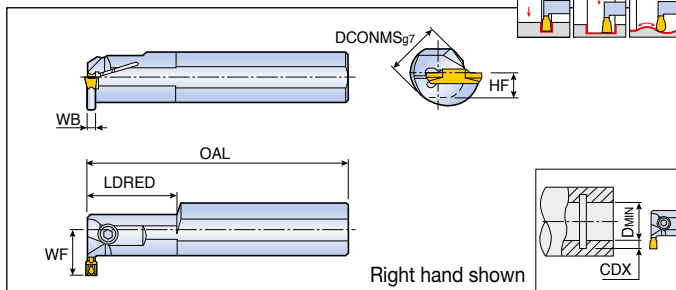

Designation	Insert seat size	Dimension (mm)								Insert
		DCONMS	OAL	LDRED	WF	HF	WB	CDX	DMIN	
TTIR/L 16-2	2	16	125	-	16.5	7.5	1.8	8.5	25	TDC/J/V/UF
20-2	2	20	160	40	15.8	9.0	1.6	6.0	25	TSC/J
25-2	2	25	200	40	17.5	11.5	1.6	5.0	25	TDCT/XU/XY/XT/T
32-2	2	32	250	60	20.8	14.0	1.5	4.7	31	TDIT
20-3	3	20	160	40	15.8	9.0	2.1	6.0	25	B129-B142
25-3	3	25	200	40	17.5	11.5	2.1	5.1	25	
32-3	3	32	250	60	20.8	14.0	2.1	4.7	31	
20-4	4	20	160	40	15.8	9.0	2.9	6.0	25	
25-4	4	25	200	40	17.5	11.5	2.9	5.2	25	
32-4	4	32	250	60	20.8	14.0	2.9	4.7	31	

- ▶ Without "C" on the description: non-coolant hole type
- ▶ Please check insert min. dia for internal grooving B89 page

Machining	TDJ/C/UF/V		TDT		TDT RU/RS		TDCT/TDXU/TDIT/TDXT/TDXV	
	Size (mm)	Min. dia. (mm)	Size (mm)	Min. dia. (mm)	Size (mm)	Min. dia. (mm)	Size (mm)	Min. dia. (mm)
Internal grooving Min. dia. of internal machining	2	40	3	40	2	41	2	24
	3	50	4	40	3	38	3	24
	4	50	5	50	4	38	4	21
	5	60	6	50	5	43	5	30
	6	60	8	62	6	46	6	31
	8	70			8	56	8	33

Spare parts

Designation	Screw	Wrench	Seal*	
TTIR/L 16-2	SH M5x0.8x10	L-W 4	PL 16 (M6)	
TTIR/L 20-2/3/4	SH M5x0.8x12	L-W 4	PL 20 (M6)	
TTIR/L 25-2/3/4	SH M5x0.8x16	L-W 4	PL 25 (R1/8)	
TTIR/L 32-2/3/4	SH M5x0.8x16	L-W 4	PL 32 (R1/8)	
TTIR/L 40-3/4	SH M5x0.8x16	L-W 4	PL 40 (R1/8)	
TTIR/L 50-4	SH M5x0.8x20	L-W 4	PL 40 (R1/8)	
TTIR/L 25-5/6	SH M6x1x16	L-W 5	PL 25 (R1/8)	
TTIR/L 32-5/6	SH M6x1x20	L-W 5	PL 32 (R1/8)	
TTIR/L 40/50-5/6	SH M6x1x25	L-W 5	PL 40 (R1/8)	

- ▶ *: For through coolant type only

TTIR/L-TB



Internal boring bars for turning and grooving with high pressure coolant

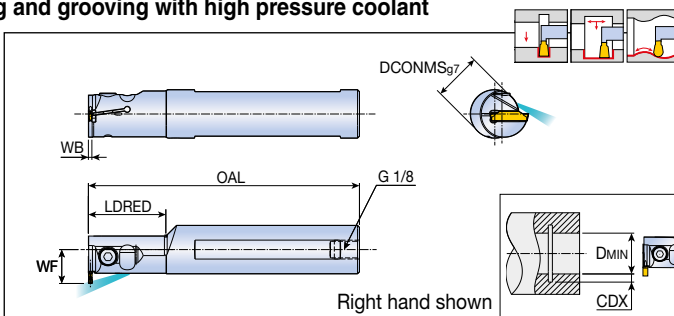

Designation	Insert seat size	Dimension (mm)							Insert
		DCONMS	OAL	LDRED	WF	WB	CDX	DMIN	
TTIR/L 20-2T06-TB	2	20	120	40	17	1.8	6	27	TDC/J/V/UF TSC/J TDCT/XU/XY/XT/T TDIT B129-B142
25-2T06-TB	2	25	150	40	19.5	1.8	6	29	
20-3T06-TB	3	20	120	40	17	2.4	6	27	
25-3T06-TB	3	25	150	40	19.5	2.4	6	29	
32-3T10-TB	3	32	150	60	27	2.4	10	40	
TTIR 20-4T06-TB	4	20	120	40	17	3	6	27	
25-4T06-TB	4	25	150	40	19.5	3	6	29	
32-4T10-TB	4	32	150	60	27	3	10	40	

- ▶ Please refer to B122 page for COOL-BURST accessories
- ▶ Please check insert min. dia for internal grooving B89 page

Spare parts

Designation	Screw	Wrench		
TTIR/L-20-TB	SH M5X0.8X12	L-W 4		
TTIR/L-25/32-TB	SH M5X0.8X16	L-W 4		

Holders for external wide grooving and profiling

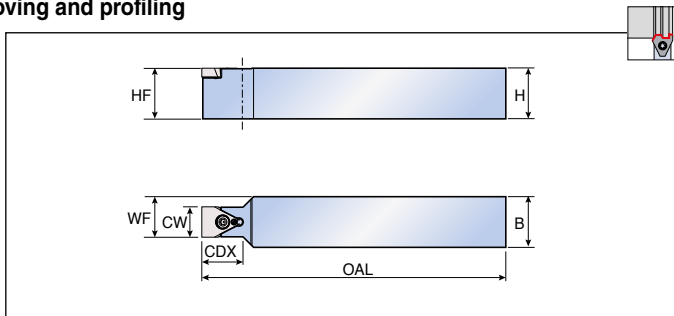

Designation	Dimension (mm)							Insert ⁽¹⁾
	H	HF	B	OAL	WF	CDX	CW	
TTLEN 1212 K10	12	12	12	125	11.0	20	10	TGUX B147
1616 K10	16	16	16	125	13.0	20	10	
2020 M10	20	20	20	150	15.0	20	10	
2525 M10	25	25	25	150	17.5	20	10	
1616 K15	16	16	16	125	15.5	20	15	
2020 M15	20	20	20	150	17.5	20	15	
2525 M15	25	25	25	150	20.0	20	15	
2020 K20	20	20	20	125	20.0	35	20	
2525 M20	25	25	25	150	22.5	35	20	
3232 P20	32	32	32	170	26.0	35	20	
2020 K25	20	20	20	125	22.5	35	25	
2525 M25	25	25	25	150	25.0	35	25	
3232 P25	32	32	32	170	28.5	35	25	

► ⁽¹⁾ Designation of final insert will be different to the semi finished blank

Spare parts

Designation	Screw 	Wrench 		
TTLEN ...K10/K15/M10/M15	TS 40B100I	T 15		
TTLEN ...K20/M20/P20	TS 45120I	T 20		
TTLEN ...K25/M25/P25	TS 45120I	T 20		

TQHR/L-20



HOLDERS for parting and grooving

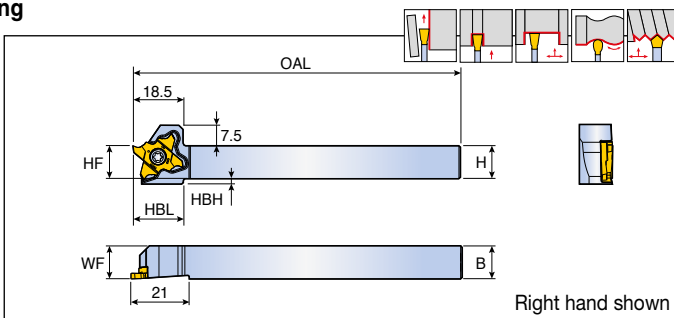

Designation	Dimension (mm)							Insert
	H	HF	B	WF	OAL	HBL	HBH	
TQHR/L 10-20	10	10	10	10	120	18.5	4	TQ... 20 B149-B150
12-20	12	12	12	12	120	18.5	2	
16-20	16	16	16	16	120	-	-	
20-20	20	20	20	20	120	-	-	
25-20	25	25	25	25.3	135	-	-	

► CDX: Refer to insert dimension

TQHR/L-20-Q



HOLDERS for parting and grooving

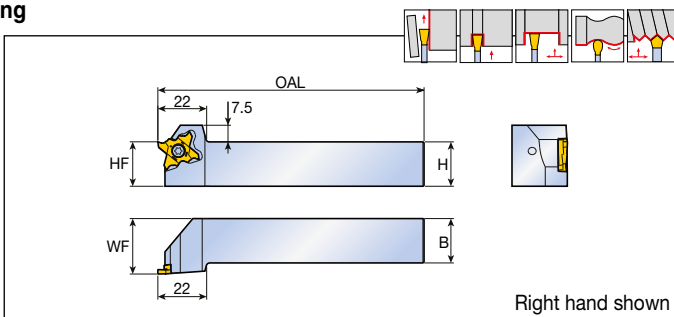

Designation	Dimension (mm)					Insert
	H	HF	B	OAL	WF	
TQHR/L 20-20-Q	20	20	20	120	25	TQ... 20 B149-B150
25-20-Q	25	25	25	135	30.3	

► CDX: Refer to insert dimension

Spare parts

Designation	Screw	Wrench		
	TQHR...	TS 40A100L	T-1508/5	
TQHL...	TS 40A100	T-1508/5		

TQHR/L-20-TB



Holders for parting and grooving with high pressure coolant

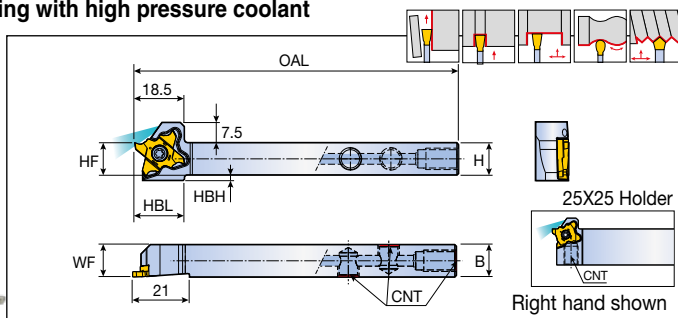

Designation	Dimension (mm)						CNT	Insert	
	H	HF	B	WF	OAL	HBL			HBH
TQHR/L 12-20-TB	12	12	12	12	120	18.5	2	UNF 5/16	TQ... 20
16-20-TB	16	16	16	16	120	-	-	UNF 5/16	B149-B150
20-20-TB	20	20	20	20	120	-	-	G 1/8	B149-B150
25-20-TB	25	25	25	25.3	135	-	-	G 1/8	

- ▶ Please refer to B122 page for COOL-BURST accessories
- ▶ CDX: Refer to insert dimension

TQHR/L-20-TB-Q



Holders for parting and grooving with high pressure coolant

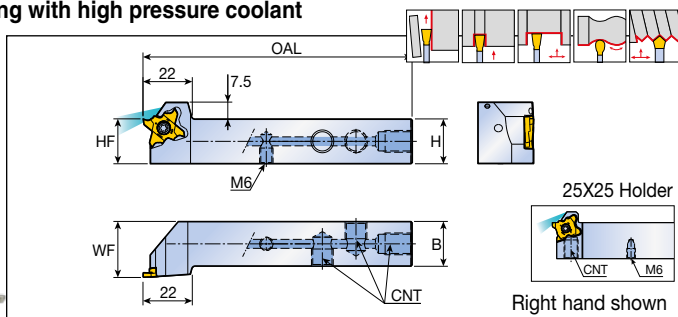

Designation	Dimension (mm)					CNT	Insert
	H	HF	B	OAL	WF		
TQHR/L 20-20-TB-Q	20	20	20	120	25	G 1/8	TQ... 20
25-20-TB-Q	25	25	25	135	30.3	G 1/8	B149-B150

- ▶ Please refer to B122 page for COOL-BURST accessories
- ▶ CDX: Refer to insert dimension

Spare parts

Designation	Screw	Plug 1	Plug 2	Wrench		
	TQHR/L 12/16-20-TB					
TQHR/L 20-20-TB	TS 40A100L ⁽¹⁾	PLG 5/16 UNF	-	T-1508/5	L-W 5/32	-
TQHR/L 25-20-TB	TS 40A100 ⁽²⁾	PLG G1/8-L6.5	-	T-1508/5	L-W 5	-
TQHR/L-TB-Q		PLG G1/8-L6.5	SS M6X1X6-NL	T-1508/5	L-W 5	L-W 3

- ▶ ⁽¹⁾ For right holder
- ▶ ⁽²⁾ For left holder

TMS-TQHIL



Sleeve holders for external grooving

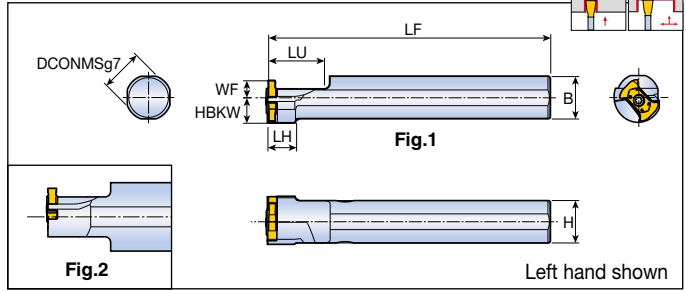

Designation	Dimension (mm)							Fig.	Insert
	DCONMS	H=B	LF	LU	LH	WF	HBKW		
TMS-TQHIL 16-14	16	15	100	20	10	6	9	1	TQIS 14
19.05-14	19.05	18	100	20	-	6	9	1	B162
20-14	20	19	100	20	20	6	9	2	
22-14	22	21	100	20	22	10	7	2	
25-14	25	24	100	20	22	10	7	2	
25.4-14	25.4	24.4	100	20	22	10	7	2	

► CDX: Refer to insert dimension

TMS-TQHIL-TB



Sleeve holders for external grooving with high pressure coolant



COOLBURST

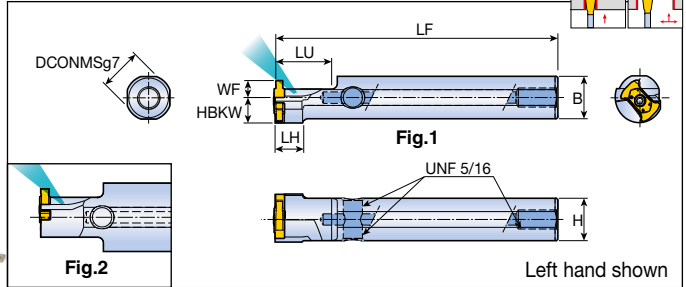

Designation	Dimension (mm)							Fig.	Insert
	DCONMS	H=B	LF	LU	LH	WF	HBKW		
TMS-TQHIL 16-14-TB	16	15	100	20	10	6	9	1	TQIS 14
25-14-TB	25	24	100	20	22	10	5	2	B162

► Please refer to B122 page for COOL-BURST accessories

► CDX: Refer to insert dimension

Spare parts

Designation	Screw	Wrench		Plug
	TMS-TQHIL	TS 25075I/HG	T 8	-
TMS-TQHIL-TB	TS 25075I/HG	T 8	L-W 5/32	PLG 5/16 UNF

TMIHR/L



Internal boring bars for shallow grooving with coolant hole on small diameter

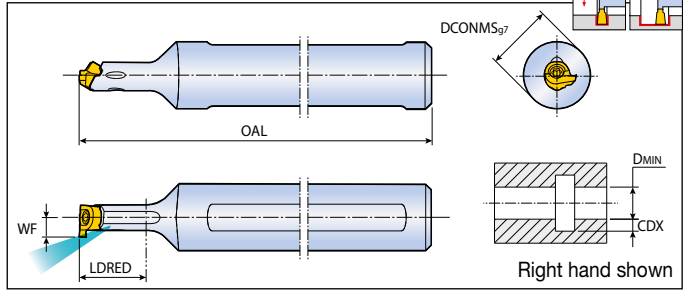

Designation	Dimension (mm)					Insert
	DCONMS	OAL	LDRED	WF	DMIN	
TMIHR/L 12-12-6	12	80	12	3.5	6.0	TMIR/L 6
12-16-8	12	80	16	4.7	8.0	TMIR/L 8 B163

► CDX: Refer to insert dimension

TMIHR/L-C



Internal carbide boring bars for shallow grooving with coolant hole on small diameter

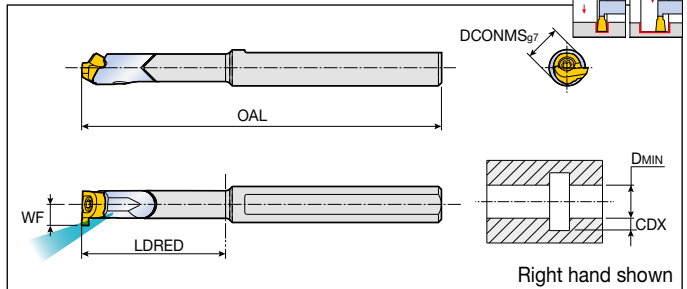

Designation	Dimension (mm)					Insert
	DCONMS	OAL	LDRED	WF	DMIN	
TMIHR/L 06C-18-6	6	54	18	3.5	6.0	TMIR/L 6
06C-24-6	6	60	24	3.5	6.0	TMIR/L 6
12C-24-8	12	92	24	4.7	8.0	TMIR/L 8 B163
12C-32-8	12	100	32	4.7	8.0	TMIR/L 8

► CDX: Refer to insert dimension

Spare parts

Designation	Screw	Wrench		
TMIHR/L 12-12-6	TS 18049/HG-P	T 6P		
TMIHR/L 12-16-8	TS 20055I	T 6		
TMIHR/L 06C	TS 18049/HG-P	T 6P		
TMIHR/L 12C	TS 20055I	T 6		

TMIHN



Internal boring bars for shallow grooving with coolant hole on small diameter

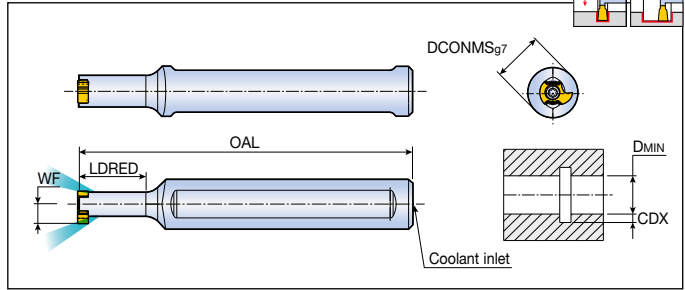

Designation	Dimension (mm)					Coolant inlet	Insert
	DCONMS	OAL	LDRED	WF	DMIN		
TMIHN 12-16-8	12	80	16	4.7	10	Ø3	TMIS 8 B163

► CDX: Refer to insert dimension

TMIHN-C



Internal carbide boring bars for shallow grooving with coolant hole on small diameter

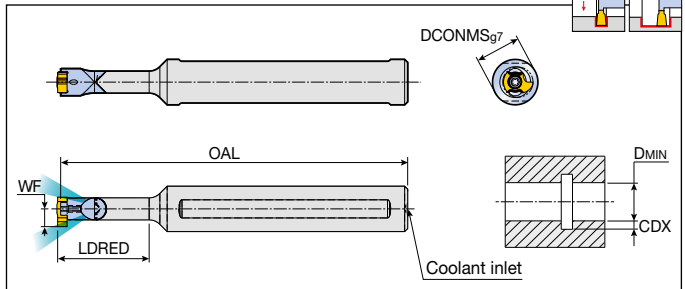

Designation	Dimension (mm)					Coolant inlet	Insert
	DCONMS	OAL	LDRED	WF	DMIN		
TMIHN 12C-24-8	12	92	24	4.7	10	Ø2	TMIS 8
12C-32-8	12	100	32	4.7	10	Ø2	B163

► CDX: Refer to insert dimension

Spare parts

Designation	Screw	Wrench		
TMIHN				
TMIHN -C	TS 22052I/HG	T 7		

Hose

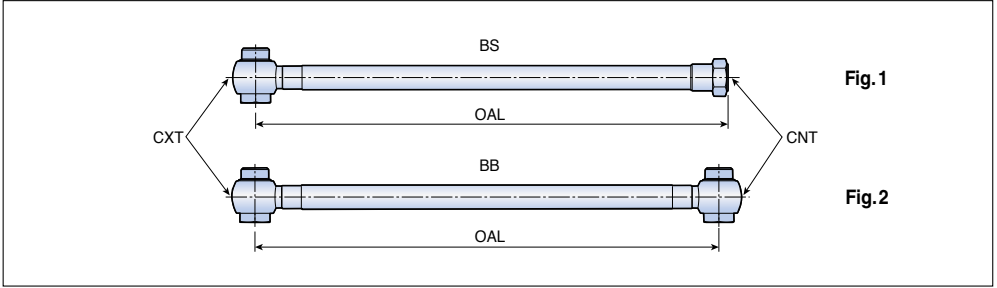

Designation	Dimension				Fig.
	OAL (mm)	CXT	CNT	Max.pressure (Bar)	
TB HOSE G1/8-7/16-200BS	200	G1/8-28 BSPP	7/16-20 UNF (Flare 37°)	260	1
G1/8-7/16-250BS	250	G1/8-28 BSPP	7/16-20 UNF (Flare 37°)	260	1
G1/8-G1/8-200BB	200	G1/8-28 BSPP	G1/8-28 BSPP	260	2
G1/8-G1/8-250BB	250	G1/8-28 BSPP	G1/8-28 BSPP	260	2
5/16-7/16-200BS	200	5/16-24 UNF	7/16-20 UNF (Flare 37°)	200	1
5/16-G1/8-200BS	200	5/16-24 UNF	G1/8-28 BSPP	200	1

► Hose is ordered separately

Spare parts

Designation	Bolt	Seal washer	
TB HOSE 5/16-7/16-200BS	TB BANJO BOLT 5/16" UNF	TB COPPER SEAL 5/16"	
TB HOSE G1/8-G1/8-200BB	TB BANJO BOLT G1/8"	TB COPPER SEAL 1/8"	
TB HOSE G1/8-G1/8-250BB	TB BANJO BOLT G1/8"	TB COPPER SEAL 1/8"	

► Bolt and Seal washer are ordered separately

Seal washer

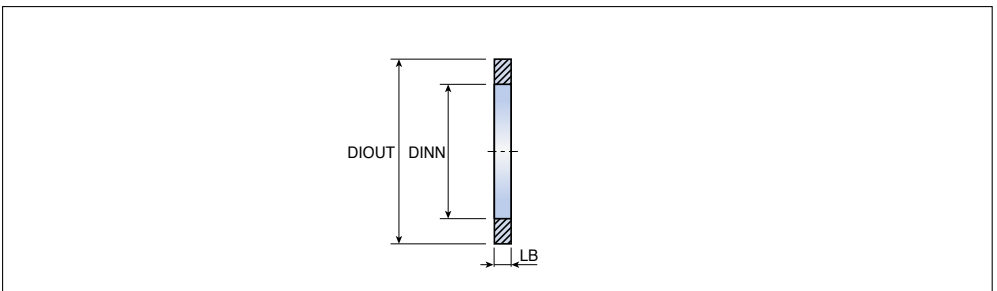

Designation	Dimension (mm)		
	DIOUT	DINN	LB
TB COPPER SEAL 1/8"	15	10	1
SEAL 5/16"	12	8	1

► Seal washer is ordered separately

Connector

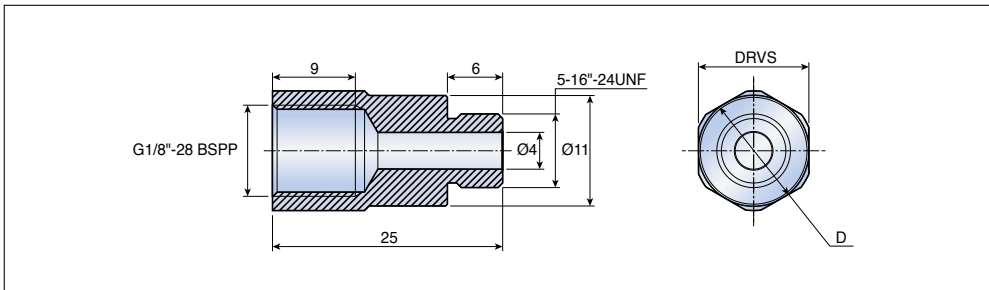

Designation	Dimension (mm)				
	D	DRVS			
TB CONECTOR 5/16"-G1/8"	13	12			
5/16"-G1/8"-12	12	11			

► Connector is ordered separately

Adapter

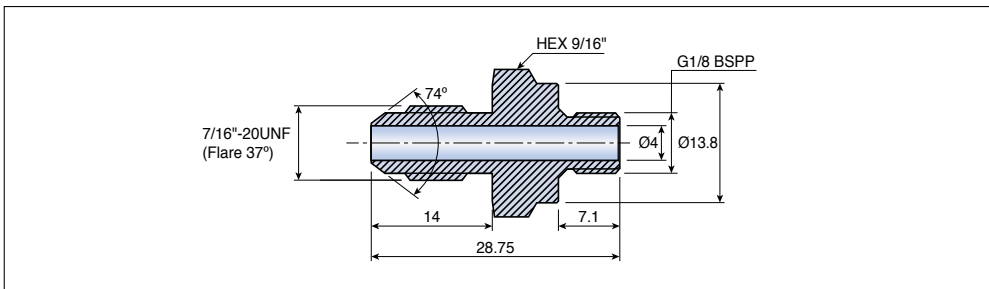

Designation
TB NIPPLE G1/8-7/16 UNF

► Adapter is ordered separately

Parting & Grooving Inserts and Solid Bars



Only for handed insert



1 TaeguTec

2 Cutting edge type

S	D
Single-ended insert	Double-ended insert

3 Chip breaker type

C	J
V	UF
For medium	For light

4 Width of insert

	2 = 2.0 mm 3 = 3.0 mm 4 = 4.0 mm 5 = 5.0 mm 6 = 6.0 mm
--	--

5 Lead angle

	Right hand shown
--	------------------

6 Hand of insert

L	R
Left hand	Right hand

7 Corner type

S	
Sharp corner	Standard corner radius

Insert Designation System

Turning, grooving and face machining

T **D** (**F**) **T** **3.00** **E** - **0.40** **R**

1 2 3 4 5 6 7 8

1 TaeguTec

2 Cutting edge type

S	D
Single-ended insert	Double-ended insert

3 Application type

F	Face turning and grooving
I	Internal turning and grooving
X	Universal

4 Chip breaker type

XU	XY	CT	T	G
Universal chip breaker (General)	Universal chip breaker (Roughing)	Universal chip breaker (Negative land)	For steel, high-temp. alloy and cast iron	Without chip breaker
M	P	RU	RS	A
Pressed for small diameter	Ground for small diameter	General profiling	Precision profiling	For aluminum

5 Width of insert (mm)

CW		<input type="checkbox"/> <input type="checkbox"/> Precision insert
		<input type="checkbox"/> Pressed insert

6 Application type

E	For turning and grooving
No designation	For precision grooving

7 Corner radius (mm)

RE		<input type="checkbox"/> <input type="checkbox"/> Precision insert
		<input type="checkbox"/> Pressed insert

8 Hand of insert - For face machining

L		R	
	Left hand insert on left hand holder		Right hand insert on right hand holder

SFC



Single-ended inserts for parting and deep grooving with C-Type chip breaker

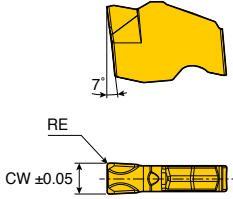

Size	Dimension (mm)			
	CW	RE		
1.6	1.6	0.2		
2	2.0	0.2		
3	3.0	0.2		

Insert	Designation	Insert seat size	Feed (mm/rev)	Cermet		Coated				Uncoated		
				CT3000		TT7505	TT6080	TT5100	TT9080	TT7220	TT8020	K10
	SFC 1.6	1	0.05-0.15						●	●		
	2	2	0.08-0.20						●	●	●	
	3	3	0.10-0.25						●	●	●	

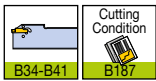

●: Standard items

SFJ



Single-ended inserts for parting and deep grooving with J-Type chip breaker

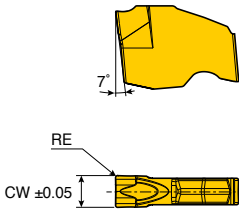

Size	Dimension (mm)			
	CW	RE		
2	2.0	0.2		
3	3.0	0.2		

Insert	Designation	Insert seat size	Feed (mm/rev)	Cermet		Coated				Uncoated		
				CT3000		TT7505	TT6080	TT5100	TT9080	TT7220	TT8020	K10
	SFJ 2	2	0.05-0.15						●	●	●	
	3	3	0.08-0.20						●	●	●	

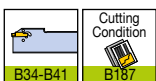

●: Standard items

Double-ended inserts for parting and grooving with C-Type chip breaker

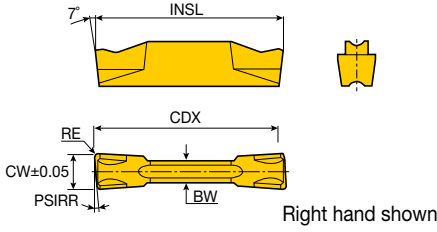

Size	Dimension (mm)					
	CW	RE	BW	INSL	PSIRR/L	CDX
2 (.R/L)	2.0	0.20	1.7	20.0	0°-15°	19
2 RS/LS	2.0	0.02	1.7	19.6	15°	19
3 (.R/L)	3.0	0.20	2.4	20.0	0°-15°	19
3 RS/LS	3.0	0.02	2.4	19.6	6°-15°	19
3.18	3.18	0.20	2.4	20.0	-	19
4 (.R/L)	4.0	0.30	3.0	20.0	0°-15°	19
5 (.R/L)	5.0	0.30	4.0	25.0	0°-4°	24
6	6.0	0.30	5.0	25.0	-	24
8	8.0	0.40	6.0	30.0	-	29

Insert	Designation	Insert seat size	Feed (mm/rev)	Cermet		Coated				Uncoated		
				CT3000		TT7505	TT6080	TT5100	TT9080	TT7220	TT8020	K10
	TDC 2	2	0.05-0.18	●					●	●	●	●
	2-6R/L	2	0.04-0.14						●	●	●	●
	2-8R/L	2	0.04-0.14						●	●		
	2-15R/L	2	0.04-0.12						●	●	●	
	2-15RS/LS	2	0.02-0.12						●	●	●	
	3	3	0.07-0.25	●			●	●	●	●	●	●
	3-6R/L	3	0.06-0.18						●	●	●	●
	3-6RS/LS	3	0.03-0.18						●	●		
	3-15R/L	3	0.06-0.16						●	●	●	
	3-15RS/LS	3	0.03-0.16						●	●	●	
	3.18	3	0.07-0.25						●	●		
	4	4	0.08-0.30	●					●	●	●	●
	4-4R/L	4	0.06-0.24						●	●	●	●
	4-15R/L	4	0.06-0.22						●	●		
	5	5	0.09-0.35						●	●	●	●
	5-4R/L	5	0.07-0.28						●	●	●	●
6	6	0.12-0.40						●	●	●	●	
8	8	0.14-0.43						●	●			



●: Standard items

TDF

Double-ended inserts for parting and grooving with UF-Type chip breaker

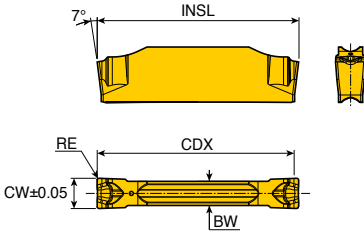

Size	Dimension (mm)				
	CW	RE	BW	INSL	CDX
2	2.0	0.2	1.5	20	19
3	3.0	0.2	2.4	20	19

Insert	Designation	Insert seat size	Feed (mm/rev)	Material							
				Cermet		Coated				Uncoated	
				CT3000	TT7505	TT6080	TT5100	TT9080	TT7220	TT8020	K10
	TDF 2	2	0.03-0.11					●			
	3	3	0.04-0.13					●			



●: Standard items

TDV

Double-ended inserts for parting and grooving with V-Type chip breaker

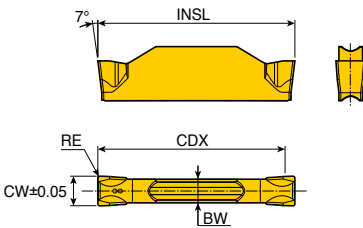

Size	Dimension (mm)				
	CW	RE	BW	INSL	CDX
2	2.0	0.2	1.7	20	19
3	3.0	0.2	2.4	20	19
4	4.0	0.3	3.0	20	19

Insert	Designation	Insert seat size	Feed (mm/rev)	Material							
				Cermet		Coated				Uncoated	
				CT3000	TT7505	TT6080	TT5100	TT9080	TT7220	TT8020	K10
	TDV 2	2	0.04-0.12					●	●		
	3	3	0.06-0.18					●	●		
	4	4	0.08-0.20					●	●		



●: Standard items

Double-ended inserts for turning and grooving

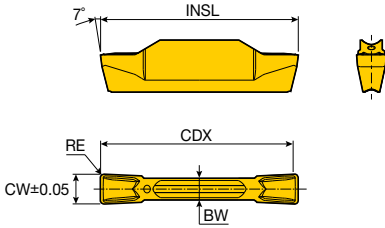

Size	Dimension (mm)				
	CW	RE	BW	INSL	CDX
2	2.0	0.30	1.7	20	19
3	3.0	0.30	2.2	20	19
4	4.0	0.40	3.0	20	19
5	5.0	0.40	4.0	25	24
6	6.0	0.40	5.0	25	24

Insert	Designation	Insert seat size	Turning		Grooving	Cermet		Coated				Uncoated
			ap (mm)	Feed (mm/rev)	Feed (mm/rev)	CT3000	TT7505	TT6080	TT5100	TT9080	TT7220	TT8020
	TDCT 2E-0.3	2	0.4-1.2	0.12-0.18	0.05-0.18			●	●	●	●	●
	3E-0.3	3	0.4-1.8	0.15-0.19	0.07-0.25			●	●	●	●	●
	4E-0.4	4	0.5-2.4	0.18-0.24	0.08-0.30			●	●			●
	5E-0.4	5	0.5-3.0	0.20-0.30	0.09-0.35			●	●			●
	6E-0.4	6	0.5-3.6	0.22-0.36	0.12-0.40			●	●			●



● Standard items

TDMV

Double-ended inserts for turning and grooving with V-type shape

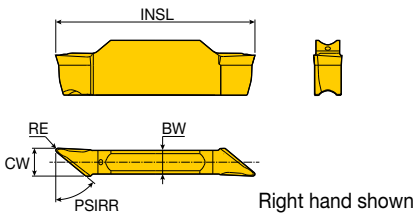

Size	Dimension (mm)				
	CW	RE	PSIRR/L	BW	INSL
2.8E-0.2	2.8	0.2	50	2.4	20
2.8E-0.4	2.8	0.4	50	2.4	20

Insert	Designation	Insert Seat Size	BWT ⁽¹⁾		FWT ⁽²⁾		Grade
			ap (mm)	Feed (mm/rev)	ap (mm)	Feed (mm/rev)	TT9080
	TDMV 2.8E-0.2-R/L	3	0.2-2.5	0.05-0.18	0.3-1.5	0.03-0.15	●
	2.8E-0.4-R/L	3	0.4-2.5	0.08-0.25	0.4-1.5	0.05-0.18	●



- ▶ Recommended to use with TGFR/L type holder
 - ▶ Lower supporter must be modified when using external grooving holder, for example TTER/L type
 - ▶ ⁽¹⁾ BWT: Backward turning
 - ▶ ⁽²⁾ FWT: Forward turning
- Standard items

Double-ended inserts for grooving, turning, face grooving and parting

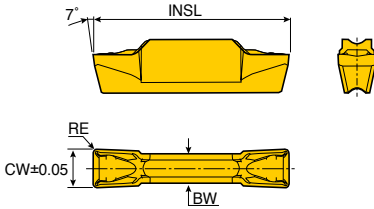

Size	Dimension (mm)			
	CW	RE	BW	INSL
2E-0.3	2.0	0.3	1.7	20.0
3E-0.3	3.0	0.3	2.2	20.0
4E-0.4	4.0	0.4	3.0	20.0
4E-0.8	4.0	0.8	3.0	20.0
5E-0.4	5.0	0.4	4.0	25.0
5E-0.8	5.0	0.8	4.0	25.0
6E-0.4	6.0	0.4	5.0	25.0
6E-0.8	6.0	0.8	5.0	25.0
8E-0.8	8.0	0.8	6.0	30.0

Insert	Designation	Insert seat size	Turning		Grooving	Cermet		Coated				Uncoated	
			ap (mm)	Feed (mm/rev)	Feed (mm/rev)	CT3000	TT7505	TT6080	TT3010	TT5100	TT9080	TT7220	TT8020
	TDXU 2E-0.3	2	0.4-1.2	0.12-0.18	0.03-0.20		●	●	●	●	●	●	●
	3E-0.3	3	0.4-1.8	0.15-0.19	0.07-0.22	●	●	●	●	●	●	●	●
	4E-0.4	4	0.5-2.4	0.18-0.24	0.08-0.27	●	●	●	●	●	●	●	●
	4E-0.8	4	1.0-2.4	0.18-0.24	0.08-0.27	●	●	●	●	●	●	●	●
	5E-0.4	5	0.5-3.0	0.20-0.30	0.10-0.30	●	●	●	●	●	●	●	●
	5E-0.8	5	1.0-3.0	0.23-0.35	0.10-0.30	●	●	●	●	●	●	●	●
	6E-0.4	6	0.5-3.6	0.22-0.36	0.13-0.40		●	●	●	●	●	●	●
	6E-0.8	6	1.0-3.6	0.24-0.42	0.13-0.40		●	●	●	●	●	●	●
8E-0.8	8	1.0-4.8	0.30-0.56	0.14-0.50		●	●	●	●	●	●	●	



●: Standard items

TDXT

Double-ended inserts for grooving, turning and face grooving

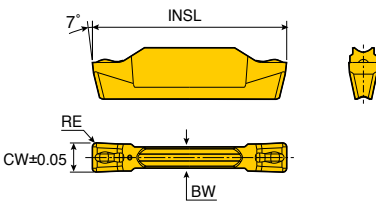

Size	Dimension (mm)			
	CW	RE	BW	INSL
3E-0.4	3.0	0.4	2.2	20.0
4E-0.4	4.0	0.4	3.0	20.0
5E-0.4	5.0	0.4	4.0	25.0
6E-0.8	6.0	0.8	5.0	25.0
8E-0.8	8.0	0.8	6.0	30.0

Insert	Designation	Insert seat size	Turning		Grooving	Cermet		Coated				Uncoated
			ap (mm)	Feed (mm/rev)	Feed (mm/rev)	CT3000	TT7505	TT6080	TT5100	TT9080	TT7220	TT8020
	TDXT 3E-0.4	3	0.5-1.8	0.15-0.22	0.06-0.15	●	●	●	●	●	●	●
	4E-0.4	4	0.5-2.4	0.18-0.30	0.07-0.20	●	●	●	●	●	●	●
	5E-0.4	5	0.5-3.0	0.20-0.35	0.08-0.23	●	●	●	●	●	●	●
	6E-0.8	6	1.0-3.6	0.24-0.42	0.12-0.30		●	●	●	●	●	●
	8E-0.8	8	1.0-4.8	0.30-0.56	0.15-0.35		●	●	●	●	●	●



▶ Non-standard grade production available at the customer's request

●: Standard items

Precision double-ended inserts for external grooving only

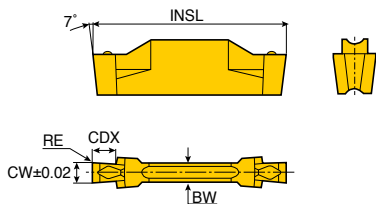

Size	Dimension (mm)				
	CW	RE	BW	INSL	CDX
1.00	1.00	0.00	2.2	20.0	2.5
1.25	1.25	0.20	2.25	20.0	2.5
1.30	1.30	0.00	2.2	20.0	2.5
1.50	1.50	0.20	2.25	20.0	2.5
1.60	1.60	0.10	2.2	20.0	2.5
1.85	1.85	0.10	2.2	20.0	3.5
2.00	2.00	0.20	2.25	20.0	3.5
2.15	2.15	0.15	2.2	20.0	3.5

Insert	Designation	Insert seat size	Grooving	Cermet		Coated				Uncoated
			Feed (mm/rev)	CT3000	TT7505	TT6080	TT5100	TT9080	TT7220	TT8020
	TDT 1.00-0.00*	2	0.02-0.04	●				●	●	●
	1.25-0.20*	2	0.02-0.05	●				●	●	●
	1.30-0.00*	2	0.02-0.05					●	●	●
	1.50-0.20*	2	0.03-0.07	●				●	●	●
	1.60-0.10*	2	0.03-0.07					●	●	●
	1.85-0.10*	2	0.03-0.09					●	●	●
	2.00-0.20	2	0.03-0.09	●				●	●	●
2.15-0.15	2	0.03-0.10					●	●	●	

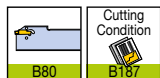

▶ *: Only for grooving. Please use TGFR/L ...-4 holder

●: Standard items

TDT-E

Double-ended inserts for turning and grooving

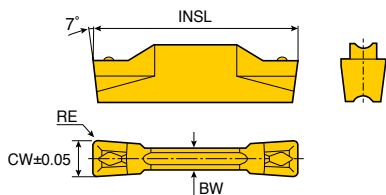

Size	Dimension (mm)			
	CW	RE	BW	INSL
3	3.0	0.4	2.2	20.0
4	4.0	0.4	3.0	20.0
6	6.0	0.8	5.0	25.0

Insert	Designation	Insert seat size	Turning		Grooving	Cermet		Ceramic		Coated				Uncoated	
			ap (mm)	Feed (mm/rev)	Feed (mm/rev)	CT3000	AB30	TT7505	TT6080	TT5100	TT9080	TT7220	TT8020	K10	
	TDT 3E-0.4	3	0.5-1.8	0.15-0.22	0.07-0.15	●				●	●	●	●	●	●
	4E-0.4	4	0.5-2.4	0.18-0.30	0.09-0.18	●				●	●	●	●	●	●
	4E-0.4T CE⁽¹⁾	4	0.5-2.4	0.18-0.30	0.09-0.35		●								
	6E-0.8T CE⁽¹⁾	6	1.0-3.6	0.24-0.42	0.13-0.40		●								



▶ ⁽¹⁾This insert is a pressed ceramic insert

●: Standard items

TDT-E (Full-Radius)



Precision double-ended inserts for external turning, grooving and profiling

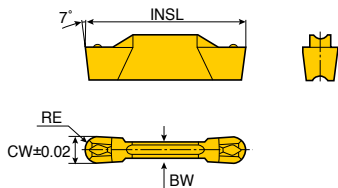

Size	Dimension (mm)			
	CW	RE	BW	INSL
3	3.00	1.50	2.2	20.0
4	4.00	2.00	3.0	20.0
4.78	4.78	2.39	4.0	25.0
5	5.00	2.50	4.0	25.0
6	6.00	3.00	5.0	25.0
8	8.00	4.00	6.0	30.0
10	10.00	5.00	8.0	30.0

Insert	Designation	Insert seat size	Turning		Grooving	Cermet		Coated				Uncoated
			ap (mm)	Feed (mm/rev)	Feed (mm/rev)	CT3000	TT7505	TT6080	TT15100	TT9080	TT7220	TT8020
	TDT 3.00E-1.50	3	0.0-1.5	0.15-0.28	0.08-0.18			●	●	●		●
	4.00E-2.00	4	0.0-2.0	0.18-0.35	0.10-0.20			●	●	●	●	●
	4.78E-2.39	5	0.0-2.4	0.20-0.42	0.12-0.23			●	●	●		
	5.00E-2.50	5	0.0-2.5	0.20-0.42	0.12-0.23			●	●	●		●
	6.00E-3.00	6	0.0-3.0	0.25-0.54	0.15-0.27			●	●	●		●
	8.00E-4.00	8	0.0-4.0	0.30-0.67	0.18-0.35			●	●	●		
	10.00E-5.00	10	0.0-5.0	0.35-0.80	0.22-0.40			●	●			



●: Standard items

TDT-RU (Full-Radius)



Double-ended inserts for external turning, grooving and profiling

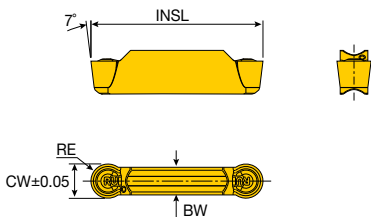

Size	Dimension (mm)			
	CW	RE	BW	INSL
2	2.0	1.0	1.7	20.0
3	3.0	1.5	2.2	20.0
4	4.0	2.0	3.0	20.0
5	5.0	2.5	4.0	25.0
6	6.0	3.0	5.0	25.0
8	8.0	4.0	6.0	30.0

Insert	Designation	Insert seat size	Turning		Grooving	Cermet		Coated				Uncoated	
			ap (mm)	Feed (mm/rev)	Feed (mm/rev)	CT3000	TT7505	TT6080	TT15100	TT3010	TT9080	TT7220	TT8020
	TDT 2E-1.0-RU	2	0.0-1.0	0.10-0.25	0.05-0.15			●	●	●	●	●	●
	3E-1.5-RU	3	0.0-1.5	0.15-0.28	0.08-0.18	●		●	●	●	●	●	●
	4E-2.0-RU	4	0.0-2.0	0.18-0.35	0.10-0.20	●		●	●	●	●	●	●
	5E-2.5-RU	5	0.0-2.5	0.20-0.42	0.12-0.23	●		●	●	●	●	●	●
	6E-3.0-RU	6	0.0-3.0	0.25-0.54	0.15-0.27	●		●	●	●	●	●	●
	8E-4.0-RU	8	0.0-4.0	0.30-0.67	0.18-0.35			●	●	●	●		●



●: Standard items

TDT-RS (Full-Radius)



Precision double-ended inserts for external turning, grooving and profiling

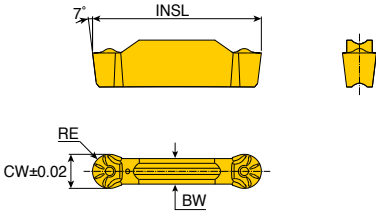

Size	Dimension (mm)			
	CW	RE	BW	INSL
2	2.0	1.0	1.7	20.0
3	3.0	1.5	2.4	20.0
4	4.0	2.0	3.0	20.0
5	5.0	2.5	4.0	25.0
6	6.0	3.0	5.0	25.0

Insert	Designation	Insert seat size	Turning		Grooving	Cermet					Coated					Uncoated
			ap (mm)	Feed (mm/rev)	Feed (mm/rev)	CT3000	TT7505	TT6080	TT5100	TT3010	TT9080	TT7220	TT8020	K10		
	TDT 2.00E-1.00-RS	2	0.0-1.0	0.10-0.22	0.08-0.15								●	●	●	
	3.00E-1.50-RS	3	0.0-1.5	0.15-0.28	0.09-0.18								●	●	●	
	4.00E-2.00-RS	4	0.0-2.0	0.18-0.35	0.10-0.20								●	●	●	
	5.00E-2.50-RS	5	0.0-2.5	0.25-0.54	0.13-0.23								●	●	●	
	6.00E-3.00-RS	6	0.0-3.0	0.30-0.67	0.15-0.27								●	●	●	



●: Standard items

TST-RS (Full-Radius)



Precision single-ended inserts for external turning, grooving and profiling

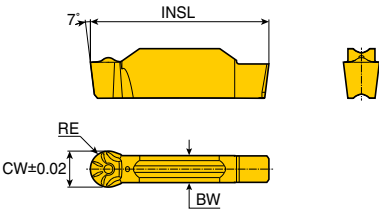

Size	Dimension (mm)			
	CW	RE	BW	INSL
3	3.00	1.50	2.4	19.8
4	4.00	2.00	3.0	19.8
5	5.00	2.50	4.0	25.0
6	6.00	3.00	5.0	25.0

Insert	Designation	Insert seat size	Turning		Grooving	Cermet					Coated					Uncoated
			ap (mm)	Feed (mm/rev)	Feed (mm/rev)	CT3000	TT7505	TT6080	TT5100	TT3010	TT9080	TT7220	TT8020	K10		
	TST 3.00E-1.50-RS	3	0.0-1.5	0.15-0.28	0.09-0.18											
	4.00E-2.00-RS	4	0.0-2.0	0.18-0.35	0.10-0.20								●	●		
	5.00E-2.50-RS	5	0.0-2.5	0.25-0.54	0.13-0.23								●	●		
	6.00E-3.00-RS	6	0.0-3.0	0.30-0.67	0.15-0.27								●	●		



●: Standard items

TDFT-E

Double-ended inserts for face grooving

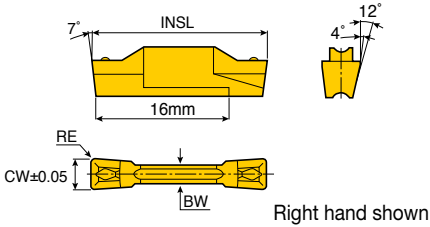

Size	Dimension (mm)			
	CW	RE	BW	INSL
3E	3.0	0.40	2.2	20.0
4E	4.0	0.40	3.0	20.0

Insert	Designation	Insert seat size	Turning		Grooving	Cermet	Coated					Uncoated
			ap (mm)	Feed (mm/rev)	Feed (mm/rev)	CT3000	TT7505	TT6080	TT15100	TT9080	TT7220	TT8020
	TDFT 3E-0.4R/L	3	0.5-2.0	0.15-0.22	0.07-0.15				●	●		●
	4E-0.4R/L	4	0.5-2.4	0.18-0.30	0.09-0.18				●	●		●



► Apply R insert on R tool and L insert on L tool

●: Standard items

TDIT-E

Precision double-ended inserts for internal turning and grooving

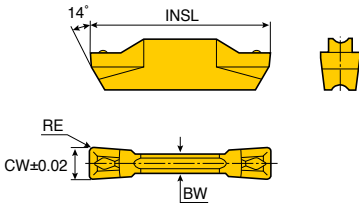

Size	Dimension (mm)			
	CW	RE	BW	INSL
3	3.00	0.40	2.2	20.0
4	4.00	0.40-0.80	3.0	20.0
5	5.00	0.40-0.80	4.0	25.0
6	6.00	0.80-1.20	5.0	25.0
8	8.00	1.20	6.0	30.0

Insert	Designation	Insert seat size	Turning		Grooving	Cermet	Coated					Uncoated
			ap (mm)	Feed (mm/rev)	Feed (mm/rev)	CT3000	TT7505	TT6080	TT15100	TT9080	TT7220	TT8020
	TDIT 3.00E-0.40	3	0.5-1.8	0.15-0.22	0.07-0.15				●	●		●
	4.00E-0.40	4	0.5-2.4	0.18-0.30	0.09-0.18				●	●		●
	4.00E-0.80	4	1.0-2.4	0.18-0.30	0.09-0.18				●	●		●
	5.00E-0.40	5	0.5-2.3	0.20-0.35	0.11-0.20				●	●		●
	5.00E-0.80	5	1.0-3.0	0.23-0.35	0.11-0.21				●	●		●
	6.00E-0.80	6	1.0-3.6	0.24-0.42	0.13-0.30				●	●		●
	6.00E-1.20	6	1.3-3.6	0.24-0.42	0.13-0.30				●	●		●
	8.00E-0.80	8	1.0-4.8	0.30-0.56	0.15-0.40				●	●		●
	8.00E-1.20	8	1.3-4.8	0.30-0.56	0.15-0.40				●	●		●



●: Standard items

TDIT-E (Full-Radius)



Precision double-ended inserts for internal turning, grooving, profiling and undercutting

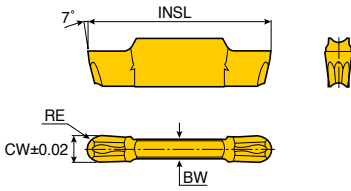

Size	Dimension (mm)			
	CW	RE	BW	INSL
3	3.00	1.50	2.2	20.0
4	4.00	2.00	3.0	20.0
5	5.00	2.50	4.0	25.0
6	6.00	3.00	5.0	25.0

Insert	Designation	Insert seat size	Turning		Grooving	Cermet		Coated			Uncoated	
			ap (mm)	Feed (mm/rev)	Feed (mm/rev)	CT3000	TT7505	TT6080	TT5100	TT9080	TT7220	TT8020
	TDIT 3.00E-1.50	3	0.0-1.5	0.15-0.28	0.08-0.18				●	●	●	
	4.00E-2.00	4	0.0-2.0	0.18-0.35	0.10-0.20				●	●	●	
	5.00E-2.50	5	0.0-2.5	0.20-0.42	0.12-0.23				●	●	●	
	6.00E-3.00	6	0.0-3.0	0.25-0.54	0.15-0.27				●	●	●	



● Standard items

TDIM



Double-ended inserts for internal turning and grooving on small diameter

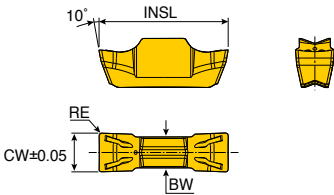

Size	Dimension (mm)			
	CW	RE	BW	INSL
2	2.0	0.15	1.6	10
3	3.0	0.20	2.4	10

Insert	Designation	Insert seat size	Turning		Grooving	Cermet		Coated			Uncoated	
			ap (mm)	Feed (mm/rev)	Feed (mm/rev)	CT3000	TT7505	TT6080	TT5100	TT9080	TT7220	TT8020
	TDIM 2E-0.15	2	0.2-0.6	0.05-0.08	0.03-0.05					●		
	3E-0.2	3	0.3-1.3	0.10-0.14	0.05-0.09					●		

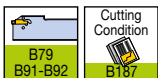

▶ Used holder TTSER/L, TTSIR/L, TGSIR/L

● Standard items

Single-ended CBN inserts for turning and grooving

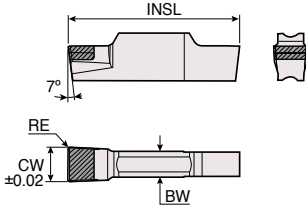

Size	Dimension (mm)				
	CW	RE	BW	INSL	
3	3.0	0.2	2.25	20.0	
4	4.0	0.2	3.0	30.0	
5	5.0	0.4	4.0	25.0	
6	6.0	0.4	5.0	25.0	
8	8.0	0.4	6.0	30.0	

Insert	Designation	Insert seat size	Turning		Grooving	CBN					PCD			
			ap (mm)	Feed (mm/rev)	Feed (mm/rev)	TB610	TB650	TB670	TB2015	TB7015	TB7020	TD1010	TD1020	TD1030
	TSG 3.00H-0.20	3	0.0-0.3	0.02-0.07	0.02-0.05				●					
	4.00H-0.20	4	0.0-0.4	0.03-0.09	0.02-0.07				●					
	5.00H-0.40	5	0.0-0.5	0.05-0.13	0.03-0.10				●					
	6.00H-0.40	6	0.0-0.6	0.05-0.15	0.04-0.12				●					
	8.00H-0.40	8	0.0-0.8	0.07-0.20	0.05-0.16				●					



●: Standard items

TSG (Full-Radius)

Single-ended CBN inserts for turning and grooving

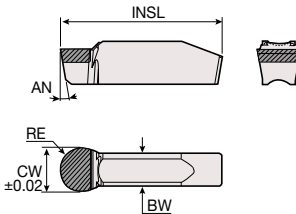

Size	Dimension (mm)					
	CW	RE	BW	INSL	AN	
3	3.0	1.5	2.4	20.0	7	
4	4.0	2.0	3.0	20.0	7	
5	5.0	2.5	4.0	25.0	7	
6	6.0	3.0	5.0	25.0	7	
8	8.0	4.0	6.0	30.0	10	

Insert	Designation	Insert seat size	Turning		Grooving	CBN					PCD			
			ap (mm)	Feed (mm/rev)	Feed (mm/rev)	TB610	TB650	TB670	TB2015	TB7015	TB7020	TD1010	TD1020	TD1030
	TSG 3.00H-1.50	3	0.0-0.3	0.03-0.10	0.02-0.06				●					
	4.00H-2.00	4	0.0-0.4	0.04-0.14	0.02-0.09				●					
	5.00H-2.50	5	0.0-0.5	0.05-0.18	0.03-0.11				●					
	6.00H-3.00	6	0.0-0.6	0.06-0.22	0.04-0.13				●					
	8.00H-4.00	8	0.0-0.8	0.08-0.29	0.05-0.17				●					



●: Standard items

TSG-HF



Single-ended CBN inserts for high feed turning

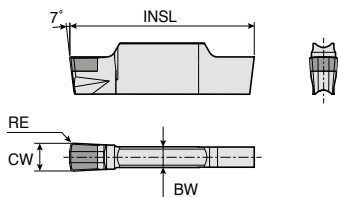

Size	Dimension (mm)				
	CW	RE	BW	INSL	
3	3.0	0.3	2.2	20	
5	5.0	0.3	4.0	25	

Insert	Designation	Insert seat size	Turning		CBN					PCD			
			ap (mm)	Feed (mm/rev)	TB610	TB650	TB670	TB2015	TB7015	TB7020	TD1010	TD1020	TD1030
	TSG 3.0-0.3-HF	3	0.08-0.12	0.40-0.80				●					
	5.0-0.3-HF	5	0.08-0.12	0.40-1.20				●					



●: Standard items

TDA/TSA



Inserts for aluminum wheel machining

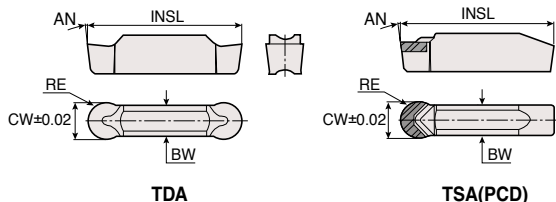

Size	Dimension (mm)				
	CW	RE	BW	INSL	AN
3	3.00	1.5	2.4	20.0	7
4	4.00	2.0	3.0	20.0	7
5	5.00	2.5	4.0	25.0	7
6	6.00	3.0	5.0	25.0	7
8	8.00	4.0	6.0	30.0	10

Insert	Designation	Insert seat size	Turning		Grooving	PCD	Coated					Uncoated
			ap (mm)	Feed (mm/rev)	Feed (mm/rev)	TD1020	TT7505	TT6080	TT5100	TT9080	TT7220	TT8020
	TDA 3.00-1.50	3	0.0-1.5	0.15-0.30	0.08-0.16							●
	4.00-2.00	4	0.0-2.0	0.20-0.43	0.10-0.22							●
	5.00-2.50	5	0.0-2.5	0.20-0.48	0.10-0.25							●
	6.00-3.00	6	0.0-3.0	0.21-0.58	0.11-0.29							●
	8.00-4.00	8	0.0-4.0	0.24-0.67	0.14-0.38							●
	TSA 6.00-3.00	6	0.0-3.0	0.26-0.72	0.13-0.36	●						
	8.00-4.00	8	0.0-4.0	0.24-0.67	0.14-0.38	●						



●: Standard items

Double-ended inserts for face grooving and turning

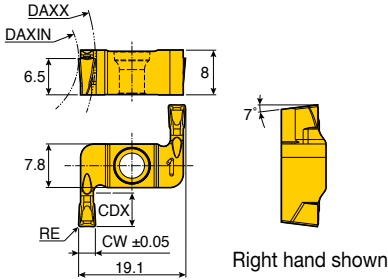

Size	Dimension (mm)				
	CW	RE	CDX	DAXIN	DAXX
2	2	0.3	6	25	N.L.
3	3	0.3	6	24	N.L.
4	4	0.4	6	32	N.L.

Insert	Designation	Turning		Grooving	Cermet		Coated			Uncoated	
		ap (mm)	Feed (mm/rev)	Feed (mm/rev)	CT3000	TT7505	TT6080	TT5100	TT9080	TT7220	TT8020
	TDFX 2E-0.3-D25R/L	0.4-1.2	0.12-0.18	0.03-0.20					●		
	3E-0.3-D24R/L	0.4-1.8	0.15-0.20	0.07-0.20				●			
	4E-0.4-D32R/L	0.5-2.4	0.15-0.24	0.09-0.25				●			

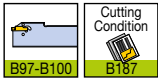

▶ N.L.: No limit

●: Standard items

TDGX

Double-ended threading inserts with 60° partial profile

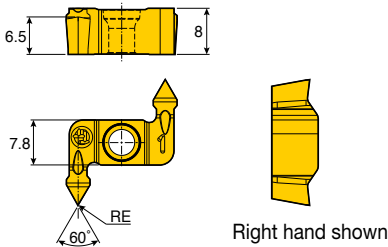

Size	Dimension (mm)				
	RE	TPN	TPX	TPIX	TPIN
4	0.05	0.45	3.5	56	8

Insert	Designation	Cermet		Coated			Uncoated			
		CT3000		TT7505	TT6080	TT5100	TT9080	TT7220	TT8020	K10
	TDGX 4MT-0.05-R/L					●				



▶ TPN: Thread pitch minimum (mm)
▶ TPX: Thread pitch maximum (mm)

▶ TPIX: Thread per inch maximum
▶ TPIN: Thread per inch minimum

●: Standard items

T **Q** **J** - **27** - **3** - **0.2** - **6** - **R**

1 2 3 4 5 6 7 8

1 TaeguTec

2 QUAD-RUSH

3 Chip breaker type

C	J	S
For medium	For light	For light & tailor made

4 Circular circumference of the insert

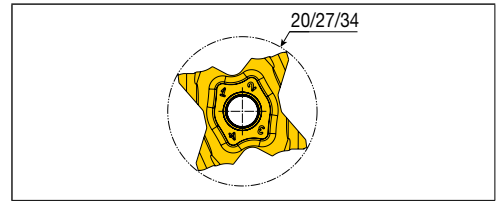

5 Width of insert

	<p>1.00 = 1.0 mm</p> <p>1.50 = 1.5 mm</p> <p>2.53 = 2.53 mm</p> <p>3.18 = 3.18 mm</p>
--	---

6 Corner radius

	<p>0.10 = 0.1 mm</p> <p>0.20 = 0.2 mm</p> <p>0.30 = 0.3 mm</p> <p>0.40 = 0.4 mm</p>
--	---

7 Lead angle

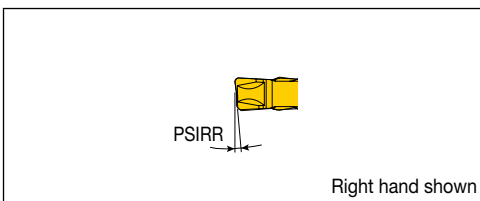

8 Hand of insert

L	R
Left-hand	Right-hand

TQS 20



Precision grooving and parting inserts with ground chip breaker

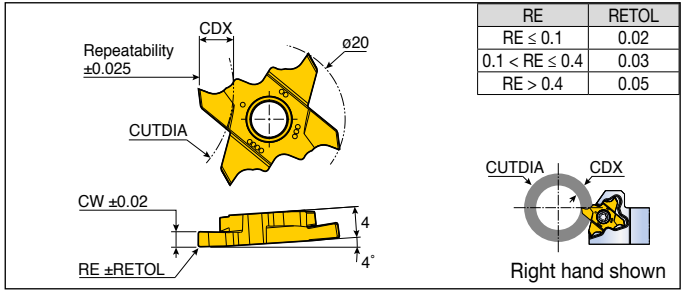

RE	RETOL
RE ≤ 0.1	0.02
0.1 < RE ≤ 0.4	0.03
RE > 0.4	0.05

Designation	Feed (mm/rev)	CW	RE	CDX	CUTDIA						Grade
					CDX ≤ 2.2	≤ 2.7	≤ 3.5	≤ 4.0	≤ 4.5	≤ 5.0	
TQS 20-0.50-0.05-R/L	0.03-0.07	0.50	0.05	2.2	N.L.	-	-	-	-	-	●
20-0.75-0.10-R/L	0.03-0.07	0.75	0.10	2.2	N.L.	-	-	-	-	-	●
20-0.95-0.10-R/L	0.03-0.07	0.95	0.10	2.2	N.L.	-	-	-	-	-	●
20-1.00-0.05-R/L	0.03-0.07	1.00	0.05	2.7	N.L.	N.L.	-	-	-	-	●
20-1.00-0.10-R/L	0.03-0.07	1.00	0.10	2.7	N.L.	N.L.	-	-	-	-	●
20-1.50-0.10-R/L	0.03-0.10	1.50	0.10	5.0	N.L.	N.L.	70	50	30	16	●
20-2.00-0.10-R/L	0.04-0.12	2.00	0.10	5.0	N.L.	N.L.	70	50	30	16	●
20-2.00-0.20-R/L	0.04-0.12	2.00	0.20	5.0	N.L.	N.L.	70	50	30	16	●
20-2.00-1.00-R/L*	0.05-0.13	2.00	1.00	5.0	N.L.	N.L.	70	50	30	16	●
20-2.50-0.10-R/L	0.04-0.15	2.50	0.10	5.0	N.L.	N.L.	70	50	30	16	●
20-3.00-0.10-R/L	0.04-0.16	3.00	0.10	5.0	N.L.	N.L.	70	50	30	16	●
20-3.00-1.50-R/L*	0.04-0.16	3.00	1.50	5.0	N.L.	N.L.	70	50	30	16	●

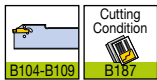

- ▶ N.L.: No limit
- ▶ *: Full radius insert

●: Standard items

TQS 20-MT



Partial profile 60° threading inserts

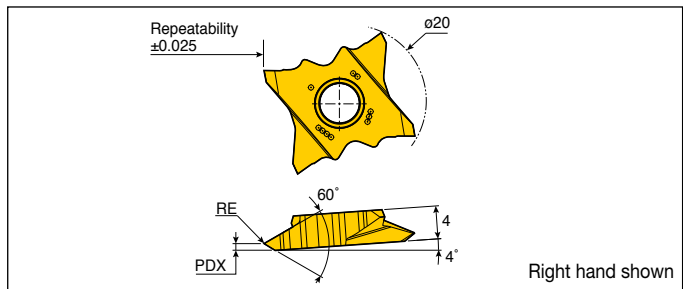

Designation	Dimension (mm)						Grade
	TPN	TPX	TPIX	TPIN	RE	PDX	
TQS 20-MT-0.05-R/L	0.30	1.75	48	14	0.05	0.8	●

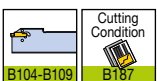

- ▶ TPN: Thread pitch minimum (mm)
- ▶ TPX: Thread pitch maximum (mm)
- ▶ TPIN: Thread per inch minimum
- ▶ TPIX: Thread per inch maximum

●: Standard items

TQJ 27



Precision grooving and parting inserts

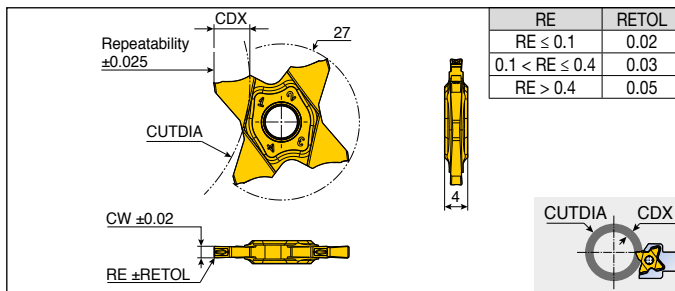

RE	RETOL
RE ≤ 0.1	0.02
0.1 < RE ≤ 0.4	0.03
RE > 0.4	0.05

Designation	Feed (mm/rev)	CW	RE	CDX	CUTDIA											Grade	
					CDX ≤ 3.0	≤ 3.5	≤ 4.0	≤ 4.5	≤ 5.0	≤ 5.5	≤ 5.7	≤ 6.0	≤ 6.2	≤ 6.4	TT9080		
TQJ 27-0.50-0.00	0.02-0.04	0.50	0.00	1.0	-	-	-	-	-	-	-	-	-	-	-	-	●
27-0.50-0.04	0.02-0.04	0.50	0.04	2.5	-	-	-	-	-	-	-	-	-	-	-	-	●
27-0.75-0.10	0.02-0.05	0.75	0.10	2.5	-	-	-	-	-	-	-	-	-	-	-	-	●
27-0.80-0.00	0.02-0.05	0.80	0.00	1.6	-	-	-	-	-	-	-	-	-	-	-	-	●
27-1.00-0.06	0.03-0.07	1.00	0.06	3.5	N.L.	600	-	-	-	-	-	-	-	-	-	-	●
27-1.00-0.10	0.03-0.07	1.00	0.10	3.5	N.L.	600	-	-	-	-	-	-	-	-	-	-	●
27-1.04-0.00	0.03-0.07	1.04	0.00	2.0	-	-	-	-	-	-	-	-	-	-	-	-	●
27-1.20-0.00	0.03-0.07	1.20	0.00	2.0	-	-	-	-	-	-	-	-	-	-	-	-	●
27-1.25-0.10	0.03-0.07	1.25	0.10	3.5	N.L.	600	-	-	-	-	-	-	-	-	-	-	●
27-1.25-0.20	0.03-0.07	1.25	0.20	3.5	N.L.	600	-	-	-	-	-	-	-	-	-	-	●
27-1.40-0.00	0.03-0.08	1.40	0.00	2.0	-	-	-	-	-	-	-	-	-	-	-	-	●
27-1.47-0.00	0.03-0.08	1.47	0.00	2.5	-	-	-	-	-	-	-	-	-	-	-	-	●
27-1.50-0.10	0.03-0.08	1.50	0.10	5.7	N.L.	600	280	180	130	50	35	-	-	-	-	-	●
27-1.50-0.20	0.03-0.08	1.50	0.20	5.7	N.L.	600	280	180	130	50	35	-	-	-	-	-	●
27-1.57-0.10	0.03-0.08	1.57	0.10	3.0	N.L.	-	-	-	-	-	-	-	-	-	-	-	●
27-1.57-0.15	0.03-0.08	1.57	0.15	3.0	N.L.	-	-	-	-	-	-	-	-	-	-	-	●
27-1.70-0.10	0.03-0.08	1.70	0.10	3.0	N.L.	-	-	-	-	-	-	-	-	-	-	-	●
27-1.75-0.10	0.03-0.08	1.75	0.10	3.0	N.L.	-	-	-	-	-	-	-	-	-	-	-	●
27-1.75-0.20	0.03-0.08	1.75	0.20	3.0	N.L.	-	-	-	-	-	-	-	-	-	-	-	●
27-1.78-0.18	0.04-0.10	1.78	0.18	3.0	N.L.	-	-	-	-	-	-	-	-	-	-	-	●
27-1.85-0.20	0.04-0.10	1.85	0.20	3.0	N.L.	-	-	-	-	-	-	-	-	-	-	-	●
27-1.96-0.15	0.04-0.10	1.96	0.15	3.0	N.L.	-	-	-	-	-	-	-	-	-	-	-	●
27-2.00-0.10	0.04-0.10	2.00	0.10	6.4	N.L.	600	280	180	130	105	85	60	50	30	-	-	●
27-2.00-0.20	0.04-0.10	2.00	0.20	6.4	N.L.	600	280	180	130	105	85	60	50	30	-	-	●
27-2.22-0.15	0.04-0.10	2.22	0.15	3.5	N.L.	600	-	-	-	-	-	-	-	-	-	-	●
27-2.30-0.20	0.04-0.10	2.30	0.20	3.5	N.L.	600	-	-	-	-	-	-	-	-	-	-	●
27-2.39-0.15	0.04-0.10	2.39	0.15	5.7	N.L.	600	280	180	130	50	35	-	-	-	-	-	●
27-2.47-0.20	0.04-0.10	2.47	0.20	5.7	N.L.	600	280	180	130	50	35	-	-	-	-	-	●
27-2.50-0.10	0.04-0.10	2.50	0.10	5.7	N.L.	600	280	180	130	50	35	-	-	-	-	-	●
27-2.50-0.30	0.05-0.12	2.50	0.30	5.7	N.L.	600	280	180	130	50	35	-	-	-	-	-	●
27-2.70-0.10	0.05-0.12	2.70	0.10	6.2	N.L.	600	280	180	135	105	95	85	78	-	-	-	●
27-2.87-0.20	0.05-0.12	2.87	0.20	6.2	N.L.	600	280	180	135	105	95	85	78	-	-	-	●

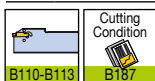

▶ N.L.: No limit

●: Standard items

TQJ 27



Precision grooving and parting inserts

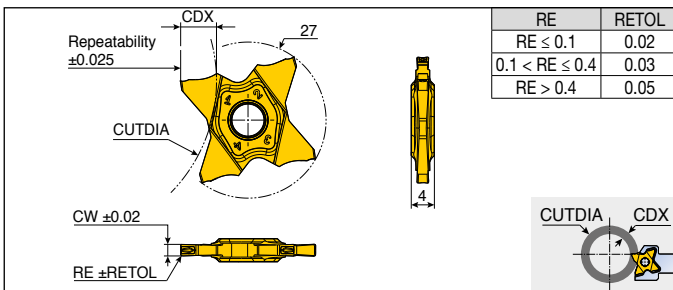

Designation	Feed (mm/rev)	CW	RE	CDX	CUTDIA										Grade
					CDX ≤ 3.0	≤ 3.5	≤ 4.0	≤ 4.5	≤ 5.0	≤ 5.5	≤ 5.7	≤ 6.0	≤ 6.2	≤ 6.4	
TQJ 27-3.00-0.00	0.05-0.12	3.00	0.00	6.4	N.L.	600	280	180	135	105	95	85	78	55	●
27-3.00-0.20	0.05-0.12	3.00	0.20	6.4	N.L.	600	280	180	135	105	95	85	78	55	●
27-3.00-0.30	0.05-0.12	3.00	0.30	6.4	N.L.	600	280	180	135	105	95	85	78	55	●
27-3.00-0.40	0.05-0.12	3.00	0.40	6.4	N.L.	600	280	180	135	105	95	85	78	55	●
27-3.15-0.15	0.05-0.12	3.15	0.15	6.4	N.L.	600	280	180	135	105	95	85	78	68	●
27-3.18-0.20	0.05-0.12	3.18	0.20	6.4	N.L.	600	280	180	135	105	95	85	78	68	●

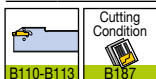

► N.L.: No limit

●: Standard items

TQJ 27



Parting inserts

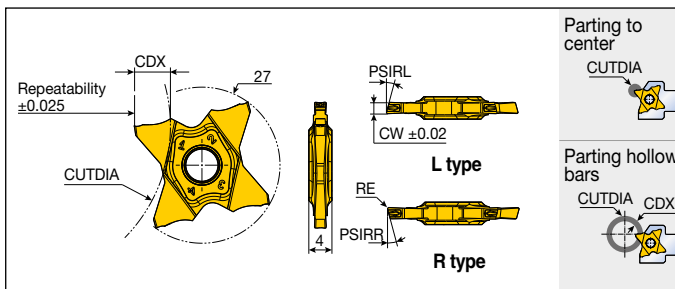

Designation	Feed (mm/rev)	CW	RE	PSIRR/L	Parting to center		Parting hollow bars		Grade
					CUTDIA	CDX	CUTDIA	TT9080	
TQJ 27-1.00-15R/L	0.02-0.06	1.00	0.06	15°	7.0	3.5	600	●	
27-1.50-6R/L	0.02-0.06	1.50	0.06	6°	12.0	5.7	35	●	
27-1.50-15R/L	0.02-0.06	1.50	0.06	15°	12.0	5.7	35	●	
27-2.00-6R/L	0.03-0.08	2.00	0.10	6°	13.0	6.4	30	●	
27-2.00-15R/L	0.03-0.08	2.00	0.10	15°	13.0	6.4	30	●	

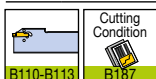

●: Standard items

TQJ 27



Full radius inserts

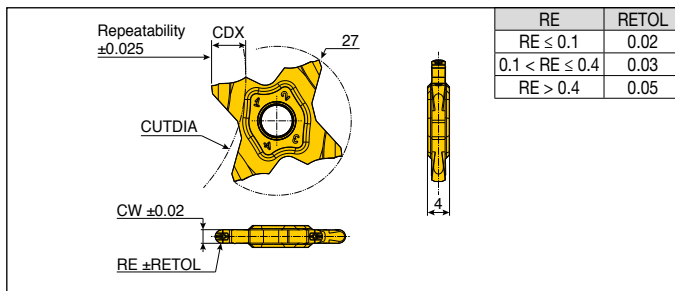

Designation	Feed (mm/rev)	CW	RE	CDX	CUTDIA										Grade	
					CDX ≤ 3.0	≤ 3.5	≤ 4.0	≤ 4.5	≤ 5.0	≤ 5.5	≤ 5.7	≤ 6.0	≤ 6.2	≤ 6.4		TT9080
TQJ 27-1.57-0.79	0.05-0.08	1.57	0.79	3.0	N.L.	-	-	-	-	-	-	-	-	-	-	●
27-2.00-1.00	0.05-0.11	2.00	1.00	3.5	N.L.	600	-	-	-	-	-	-	-	-	-	●
27-2.39-1.20	0.05-0.11	2.39	1.20	5.7	N.L.	600	280	180	130	50	35	-	-	-	-	●
27-3.00-1.50	0.06-0.12	3.00	1.50	6.4	N.L.	600	280	180	135	105	95	85	78	55	-	●

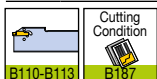

► N.L.: No limit

●: Standard items

TQJ 27



DIN 471 circlip grooving and shallow grooving inserts

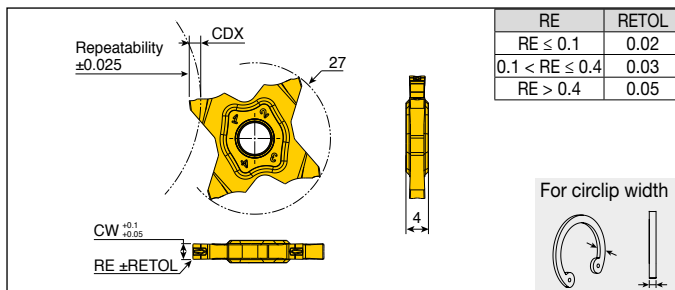

Designation	Feed (mm/rev)	CW	RE	CDX	For circlip width	Grade
						TT9080
TQJ 27-1.10-0.08-CG	0.03-0.07	1.10	0.08	1.50	1.10	●
27-1.30-0.08-CG	0.03-0.07	1.30	0.08	1.50	1.30	●
27-1.60-0.08-CG	0.03-0.08	1.60	0.08	2.00	1.60	●
27-1.85-0.08-CG	0.03-0.08	1.85	0.08	2.00	1.85	●
27-2.15-0.08-CG	0.04-0.10	2.15	0.08	2.50	2.15	●
27-2.65-0.15-CG	0.05-0.12	2.65	0.15	2.50	2.65	●

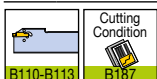

► When selecting insert, please keep in your mind insert tolerance

●: Standard items

TQC 27



Precision grooving and parting inserts

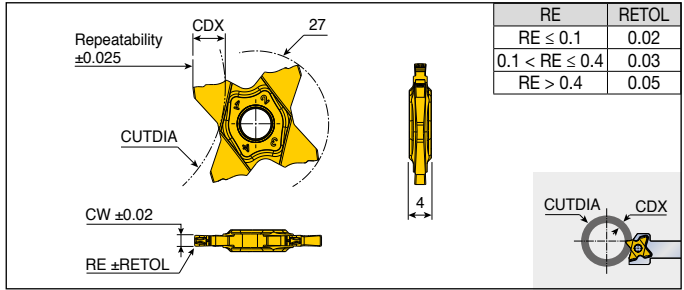

RE	RETOL
RE ≤ 0.1	0.02
0.1 < RE ≤ 0.4	0.03
RE > 0.4	0.05

Designation	Feed (mm/rev)	CW	RE	CDX	CUTDIA										Grade	
					CDX ≤ 3.0	≤ 3.5	≤ 4.0	≤ 4.5	≤ 5.0	≤ 5.5	≤ 5.7	≤ 6.0	≤ 6.2	≤ 6.4		≤ 6.5
TQC 27-1.50-0.10	0.05-0.08	1.50	0.10	5.7	N.L.	600	280	180	130	50	35	-	-	-	-	●
27-1.50-0.20	0.05-0.06	1.50	0.20	5.7	N.L.	600	280	180	130	50	35	-	-	-	-	●
27-1.57-0.15	0.05-0.08	1.57	0.15	3.0	N.L.	-	-	-	-	-	-	-	-	-	-	●
27-1.70-0.10	0.05-0.09	1.70	0.10	3.0	N.L.	-	-	-	-	-	-	-	-	-	-	●
27-1.75-0.10	0.05-0.10	1.75	0.10	3.0	N.L.	-	-	-	-	-	-	-	-	-	-	●
27-1.75-0.20	0.05-0.09	1.75	0.20	3.0	N.L.	-	-	-	-	-	-	-	-	-	-	●
27-1.78-0.18	0.05-0.11	1.78	0.18	3.0	N.L.	-	-	-	-	-	-	-	-	-	-	●
27-1.85-0.20	0.05-0.11	1.85	0.20	3.0	N.L.	-	-	-	-	-	-	-	-	-	-	●
27-1.96-0.15	0.05-0.11	1.96	0.15	3.0	N.L.	-	-	-	-	-	-	-	-	-	-	●
27-2.00-0.10	0.05-0.17	2.00	0.10	6.4	N.L.	600	280	180	130	105	85	60	50	30	-	●
27-2.00-0.20	0.05-0.15	2.00	0.20	6.4	N.L.	600	280	180	130	105	85	60	50	30	-	●
27-2.22-0.15	0.05-0.15	2.22	0.15	3.5	N.L.	600	-	-	-	-	-	-	-	-	-	●
27-2.30-0.20	0.05-0.16	2.30	0.20	3.5	N.L.	600	-	-	-	-	-	-	-	-	-	●
27-2.39-0.15	0.05-0.16	2.39	0.15	5.7	N.L.	600	280	180	130	50	35	-	-	-	-	●
27-2.47-0.20	0.05-0.19	2.47	0.20	5.7	N.L.	600	280	180	130	50	35	-	-	-	-	●
27-2.50-0.10	0.05-0.20	2.50	0.10	5.7	N.L.	600	280	180	130	50	35	-	-	-	-	●
27-2.50-0.30	0.05-0.17	2.50	0.30	5.7	N.L.	600	280	180	130	50	35	-	-	-	-	●
27-2.70-0.10	0.05-0.19	2.70	0.10	6.2	N.L.	600	280	180	135	105	95	85	78	-	-	●
27-2.87-0.20	0.05-0.19	2.87	0.20	6.2	N.L.	600	280	180	135	105	95	85	78	-	-	●
27-3.00-0.00	0.05-0.11	3.00	0	6.4	N.L.	600	280	180	135	105	95	85	78	55	-	●
27-3.00-0.20	0.06-0.23	3.00	0.20	6.4	N.L.	600	280	180	135	105	95	85	78	55	-	●
27-3.00-0.30	0.06-0.25	3.00	0.30	6.4	N.L.	600	280	180	135	105	95	85	78	55	-	●
27-3.00-0.40	0.06-0.25	3.00	0.40	6.4	N.L.	600	280	180	135	105	95	85	78	55	-	●
27-3.15-0.15	0.06-0.21	3.15	0.15	6.4	N.L.	600	280	180	135	105	95	85	78	68	-	●
27-3.18-0.20	0.06-0.23	3.18	0.20	6.4	N.L.	600	280	180	135	105	95	85	78	68	-	●
27-3.30-0.10	0.06-0.23	3.30	0.10	6.5	N.L.	600	280	180	135	105	85	65	50	40	35	●
27-3.48-0.20	0.06-0.23	3.48	0.20	6.5	N.L.	600	280	180	135	105	85	65	50	40	35	●
27-3.56-0.20	0.06-0.23	3.56	0.20	6.5	N.L.	600	280	180	135	105	85	65	55	40	35	●
27-3.74-0.20	0.06-0.23	3.74	0.20	6.5	N.L.	600	280	180	135	105	85	65	55	40	35	●
27-3.98-0.20	0.07-0.30	3.98	0.20	6.5	N.L.	600	280	180	135	105	95	85	78	40	45	●
27-4.00-0.30	0.07-0.30	4.00	0.30	6.5	N.L.	600	280	180	135	105	95	85	78	40	45	●
27-4.00-0.40	0.07-0.30	4.00	0.40	6.5	N.L.	600	280	180	135	105	95	85	78	40	45	●
27-4.00-0.80	0.07-0.30	4.00	0.80	6.5	N.L.	600	280	180	135	105	95	85	78	40	45	●
27-4.15-0.15	0.07-0.30	4.15	0.15	6.5	N.L.	600	280	180	135	105	95	85	78	40	45	●
27-4.23-0.10	0.07-0.30	4.23	0.10	6.5	N.L.	600	280	180	135	105	95	85	78	55	65	●

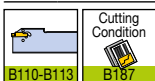

▶ N.L.: No limit

●: Standard items

TQC 27



Parting inserts

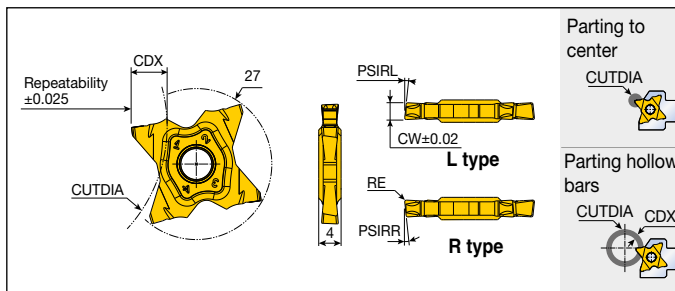

Designation	Feed (mm/rev)	CW	RE	PSIRR/L	Parting to center			Parting hollow bars			Grade
					CUTDIA	CDX	CUTDIA	CDX	CUTDIA		
TQC 27-1.50-6R/L	0.03-0.07	1.50	0.06	6°	12.0	5.7	35				●
27-1.50-15R/L	0.03-0.07	1.50	0.06	15°	12.0	5.7	35				●
27-2.00-6R/L	0.04-0.14	2.00	0.10	6°	13.0	6.4	30				●
27-2.00-15R/L	0.04-0.14	2.00	0.10	15°	13.0	6.4	30				●

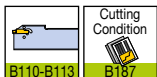

●: Standard items

TQC 27



Full radius inserts

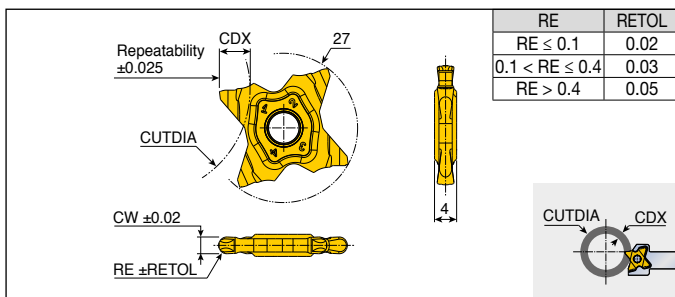

Designation	Feed (mm/rev)	CW	RE	CDX	CUTDIA											Grade		
					CDX ≤ 3.0	≤ 3.5	≤ 4.0	≤ 4.5	≤ 5.0	≤ 5.5	≤ 5.7	≤ 6.0	≤ 6.2	≤ 6.4				
TQC 27-1.57-0.79	0.05-0.09	1.57	0.79	3.0	N.L.	-	-	-	-	-	-	-	-	-	-	-	-	●
27-2.00-1.00	0.05-0.13	2.00	1.00	3.5	N.L.	600	-	-	-	-	-	-	-	-	-	-	-	●
27-2.39-1.20	0.06-0.17	2.39	1.20	5.7	N.L.	600	280	180	130	50	35	-	-	-	-	-	-	●
27-3.00-1.50	0.06-0.20	3.00	1.50	6.4	N.L.	600	280	180	135	105	95	85	78	55	-	-	-	●

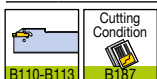

► N.L.: No limit

●: Standard items

TQS 27-MT



Partial profile 60° threading inserts

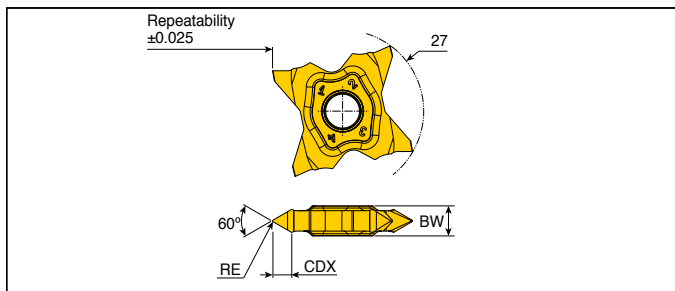

Designation	Dimension (mm)							Grade TT9080
	TPN	TPX	TPIX	TPIN	RE	BW	CDX	
TQS 27-4MT-0.05	0.45	3	48	8	0.05	4	2.8	●
27-4MT-0.14	1.11	3	23	8	0.14	4	2.7	●
27-5MT-0.15	1.25	3	20	8	0.15	5	3.1	●
27-5MT-0.20	1.63	3	16	8	0.20	5	3.1	●
27-6MT-0.25	1.94	3	13	8	0.25	6	3.6	●

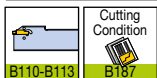

- ▶ TPN: Thread pitch minimum (mm)
- ▶ TPX: Thread pitch maximum (mm)
- ▶ TPIX: Thread per inch maximum
- ▶ TPIN: Thread per inch minimum
- : Standard items

TQS 27-WT



Partial profile 55° threading inserts

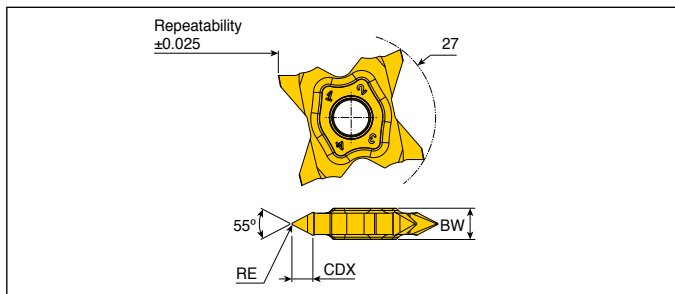

Designation	Dimension (mm)						Grade TT9080
	TPIX	TPIN	RE	BW	CDX		
TQS 27-4WT-0.05	54	10	0.05	4	2.9	●	
27-5WT-0.15	19	10	0.15	5	3.3	●	
27-6WT-0.25	12	9	0.25	6	3.9	●	

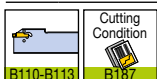

- ▶ TPIX: Thread per inch maximum
- ▶ TPIN: Thread per inch minimum
- : Standard items



TQS 27-ISO



ISO metric full profile, external threading inserts

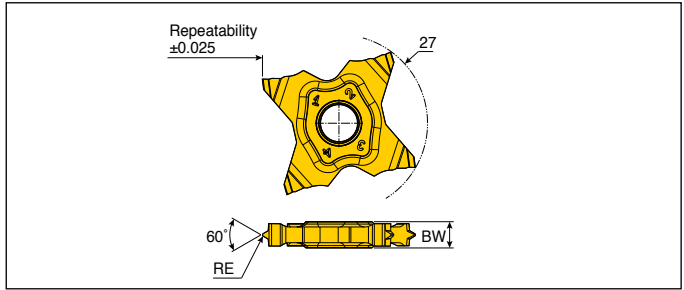

Designation	Dimension (mm)			Grade
	TP	RE	BW	TT9080
TQS 27-0.5-ISO	0.50	0.08	4	●
27-0.75-ISO	0.75	0.11	4	●
27-0.8-ISO	0.80	0.12	4	●
27-1.0-ISO	1.00	0.14	4	●
27-1.25-ISO	1.25	0.18	4	●
27-1.5-ISO	1.50	0.22	4	●
27-1.75-ISO	1.75	0.25	4	●
27-2.0-ISO	2.00	0.28	4	●

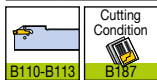

▶ TP: Thread pitch (mm)

●: Standard items

TQS 27-UN



American UN (UNC, UNF, UNEF) full profile, external threading inserts

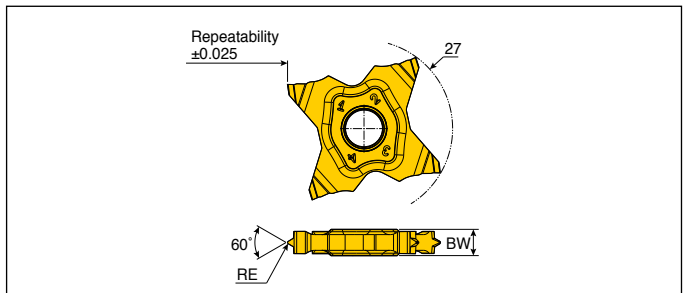

Designation	Dimension (mm)			Grade
	TPI	RE	BW	TT9080
TQS 27-24-UN	24	0.13	4	●
27-20-UN	20	0.16	4	●
27-18-UN	18	0.16	4	●
27-16-UN	16	0.21	4	●
27-14-UN	14	0.23	4	●
27-12-UN	12	0.27	4	●

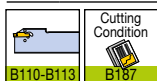

▶ TPI: Thread per inch

●: Standard items

TQS 27-W



Whitworth (BSW, BSF, BSP) full profile, external threading inserts

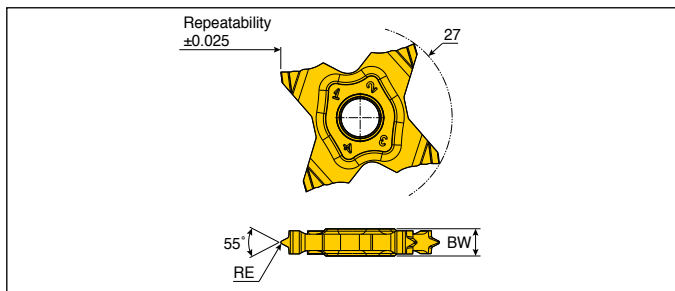

Designation	Dimension (mm)			Grade TT9080
	TPI	RE	BW	
TQS 27-28-W	28	0.09	4	●
27-19-W	19	0.15	4	●
27-18-W	18	0.16	4	●
27-16-W	16	0.19	4	●
27-14-W	14	0.21	4	●
27-12-W	12	0.25	4	●

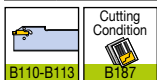

► TPI: Thread per inch

●: Standard items

TQBS 27



4 cutting edges with semi-finished blanks for wide grooving and profiling

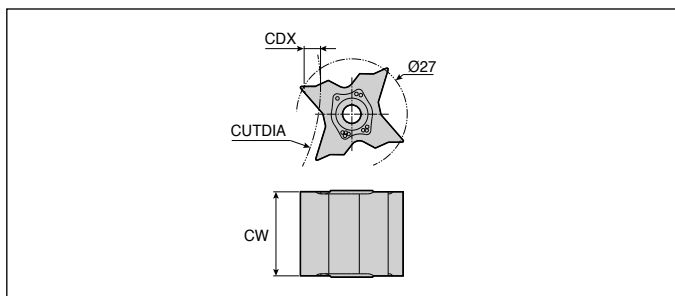

Designation	Dimension (mm)		CUTDIA										Grade UF10
	CW	BW	CDX ≤ 3.0	≤ 3.5	≤ 4.0	≤ 4.5	≤ 5.0	≤ 5.5	≤ 5.7	≤ 6.0	≤ 6.2	≤ 6.4	
TQBS 27-10EW	10.5	11.1	N.L.	600	280	180	135	105	95	85	78	55	●
27-15EW	15.5	16.1	N.L.	600	280	180	135	105	95	85	78	55	●
27-20EW	20.5	21.1	N.L.	600	280	180	135	105	95	85	78	55	●

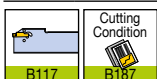

► N.L.: No limit

●: Standard items

TQC 34



Parting inserts

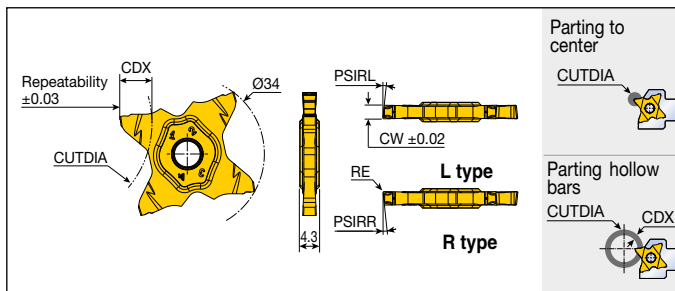

Designation	Feed (mm/rev)	CW	RE	PSIRR/L	Parting to center		Parting hollow bars		Grade
					CUTDIA	CDX	CUTDIA		
TQC 34-1.50-8R/L	0.03-0.10	1.50	0.07	8°	18.5	9	40	●	
34-2.00-6R/L	0.03-0.15	2.00	0.10	6°	18.5	9	40	●	
34-2.00-15R/L	0.03-0.15	2.00	0.10	15°	18.5	9	40	●	
34-3.00-6R/L	0.03-0.18	3.00	0.20	6°	20.0	10	20	●	

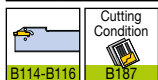

● Standard items

TQC 34



Full radius inserts

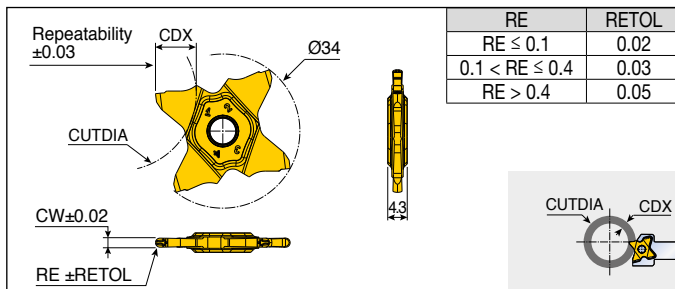

Designation	Feed (mm/rev)	CW	RE	CDX	CUTDIA							Grade
					CDX ≤ 4.0	≤ 5.0	≤ 6.0	≤ 7.0	≤ 8.0	≤ 9.0	≤ 10.0	
TQC 34-2.00-1.00	0.05-0.11	2.00	1.00	9.0	N.L.	400	190	125	90	40	-	●
34-2.39-1.20	0.05-0.11	2.39	1.20	10.0	N.L.	400	190	125	90	45	20	●
34-3.00-1.50	0.06-0.12	3.00	1.50	10.0	N.L.	400	190	125	90	50	20	●

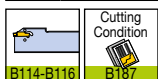

► N.L.: No limit

● Standard items

TMIR/L



Precise inserts for internal shallow grooving on small diameter

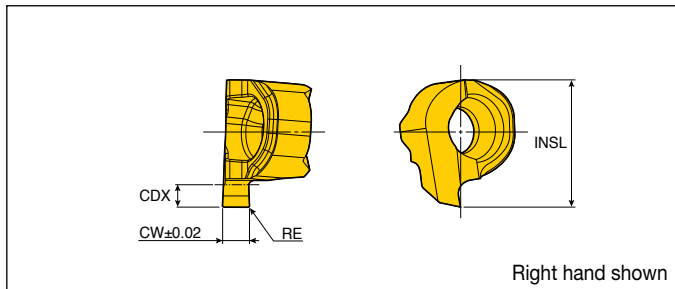

Designation	Feed (mm/rev)	Dimension (mm)				Grade	
		CW	RE	CDX	INSL	TT4430	TT8020
TMIR/L 6-0.50-0.00	0.01-0.03	0.50	0.00	0.5	5.7	●	●
6-1.00-0.00	0.01-0.03	1.00	0.00	1.0	5.7	●	●
6-1.20-0.05	0.01-0.03	1.20	0.05	1.0	5.7	●	●
8-0.50-0.00	0.01-0.03	0.50	0.00	0.7	7.4	●	●
8-1.00-0.00	0.01-0.03	1.00	0.00	1.5	7.4	●	●
8-1.50-0.05	0.01-0.03	1.50	0.05	1.5	7.4	●	●
8-2.00-0.10	0.01-0.03	2.00	0.10	1.5	7.4	●	●

●: Standard items

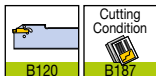

TMIS 8



Precise inserts for internal shallow grooving on small diameter

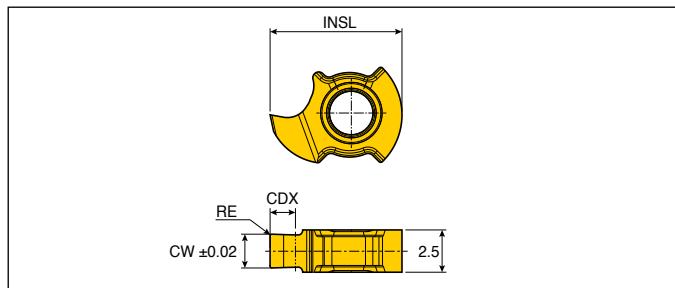

Designation	Feed (mm/rev)	Dimension (mm)				Grade	
		CW	RE	CDX	INSL	TT4430	TT8020
TMIS 8-0.50-0.00	0.01-0.03	0.50	0.00	0.70	7.8	●	●
8-1.00-0.00	0.01-0.03	1.00	0.00	1.50	7.8	●	●
8-1.50-0.05	0.01-0.03	1.50	0.05	1.50	7.8	●	●
8-2.00-0.10	0.01-0.03	2.00	0.10	1.50	7.8	●	●

●: Standard items

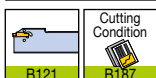

TV **E** **R** **4** **07** **010** **45**
1 2 3 4 5 6 7

1 TaeguTec TOP-CUT series

2 Application type

E External turning
R Reverse turning
B Back turning
T Threading
P Parting

3 Hand of tool

R Right-hand
L Left-hand

4 Insert thickness

4 3.97mm

5 Width of insert

07 0.7mm
10 1.0mm
12 1.2mm
15 1.5mm
18 1.8mm
20 2.0mm

6 Corner radius

000 0mm
003 0.03mm
005 0.05mm
010 0.10mm
015 0.15mm

7 CDX (TVPR/L only)

45 4.5mm
50 5.0mm
60 6.0mm

TVER/L



General turning inserts

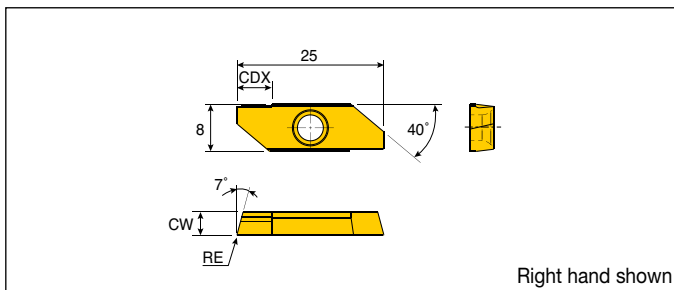

Designation	ap (mm)	Feed (mm/rev)	Dimension (mm)			Grade (TT9010)	
			CW	RE	CDX	R	L
TVER/L 40003	0.1-5.5	0.01-0.15	3.97	0.03	5.5	●	
40010	0.1-5.5	0.01-0.15	3.97	0.10	5.5	●	



●: Standard items

TVRR/L



Reverse turning inserts

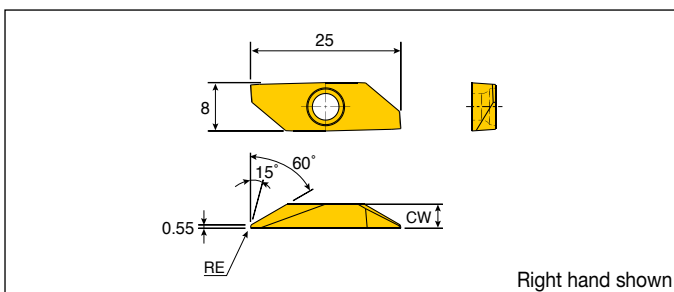

Designation	ap (mm)	Feed (mm/rev)	Dimension (mm)			Grade (TT9010)	
			CW	RE	CDX	R	L
TVRR/L 40003-60	0.1-5.5	0.01-0.15	3.97	0.03	5.5	●	
40010-60	0.1-5.5	0.01-0.15	3.97	0.10	5.5	●	



●: Standard items

Back turning inserts

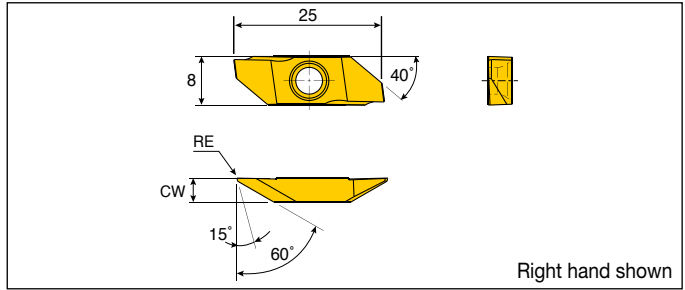

Designation	ap (mm)	Feed (mm/rev)	Dimension (mm)			Grade (TT9010)	
			CW	RE	CDX	R	L
TVBR/L 40003	0.1-5.5	0.01-0.15	3.97	0.03	5.5	●	●
40005	0.1-5.5	0.01-0.15	3.97	0.05	5.5	●	●
40010	0.1-5.5	0.01-0.15	3.97	0.10	5.5	●	●
40015	0.1-5.5	0.01-0.15	3.97	0.15	5.5	●	●
40005-H⁽¹⁾	0.1-5.5	0.01-0.15	3.97	0.05	5.5	●	●
40015-H⁽¹⁾	0.1-5.5	0.01-0.15	3.97	0.15	5.5	●	●



► ⁽¹⁾ With honed edges

●: Standard items

TVTR/L

Threading inserts

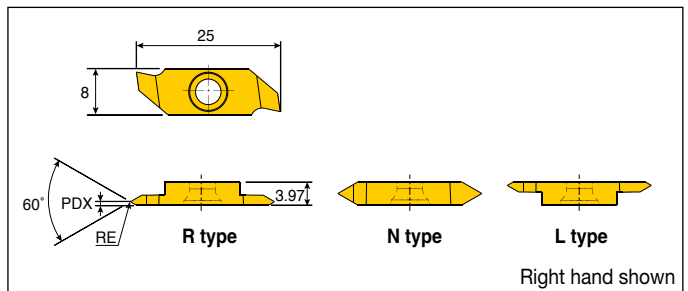

Designation	Dimension (mm)				Grade (TT9010)	
	TPN	TPX	PDX	RE	R	L
TVTR/L 41203-R	0.5	1.0	0.6	0.03	●	
40003-N	0.5	2.0	2.1	0.03	●	●
41203-L	0.5	1.0	0.6	0.03		●



► TVTR 41203-R/L → pitch range: 0.5 - 1.0mm

► TVTR 40003-N → pitch range: 0.5 - 2.0mm

► TPN: Thread pitch minimum (mm), TPX: Thread pitch maximum (mm)

●: Standard items

Grooving and parting inserts

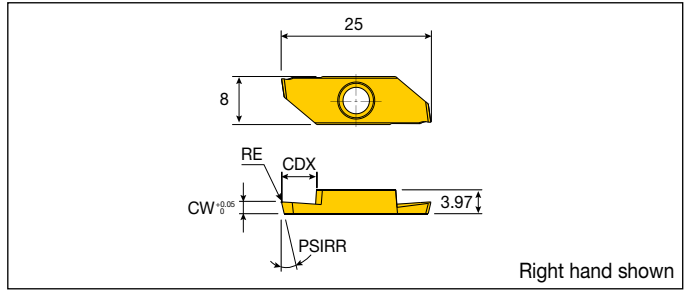

Designation	ap (mm)	Feed (mm/rev)	Dimension (mm)				Grade (TT9010)	
			CW	RE	PSIRR/L	CDX	R	L
TVPR/L 40700-45	0.7	0.02-0.04	0.7	0.00	15°	4.5	●	●
40705-45	0.7	0.02-0.04	0.7	0.05	15°	4.5	●	
41000-60	1.0	0.02-0.04	1.0	0.00	15°	6.0	●	●
41005-60	1.0	0.02-0.04	1.0	0.05	15°	6.0	●	
41000-45	1.0	0.02-0.04	1.0	0.00	15°	4.5	●	
41005-45	1.0	0.02-0.04	1.0	0.05	15°	4.5	●	
41500-60	1.5	0.02-0.07	1.5	0.00	15°	6.0	●	●
41505-60	1.5	0.02-0.07	1.5	0.05	15°	6.0	●	
41500-50	1.5	0.02-0.07	1.5	0.00	15°	5.0	●	
41505-50	1.5	0.02-0.07	1.5	0.05	15°	5.0	●	
42000-60	2.0	0.02-0.07	2.0	0.00	15°	6.0	●	●
42005-60	2.0	0.02-0.07	2.0	0.05	15°	6.0	●	
42000N-60	2.0	0.02-0.09	2.0	0.00	0°	6.0	●	●
42005N-60	2.0	0.02-0.09	2.0	0.05	0°	6.0	●	

●: Standard items



MIN	T	R	04	040	005	D010
1	7	2	3	4	5	6

1 TOP-MICRO series

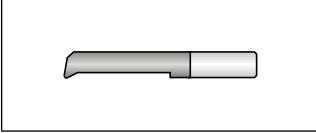

2 Hand of tool

R Right-hand
L Left-hand

3 Shank dia.

04 4.0mm
07 7.0mm

4 Max. depth

050 5.0mm
140 14.0mm

5 Corner radius

010 0.10mm
020 0.20mm

6 Min. bore dia.

D010 1.0mm

7 Application type

T	Turning and chamfering
B	Back turning
P	Turning and profiling
U	Undercutting and chamfering
C	Turning and 45° chamfering
G	Grooving and turning
S	Grooving along shaft
F	Face grooving
R	Full radius for internal boring and profiling
I	ISO full profile internal threading
SL	Sleeve for MINS

Sleeves

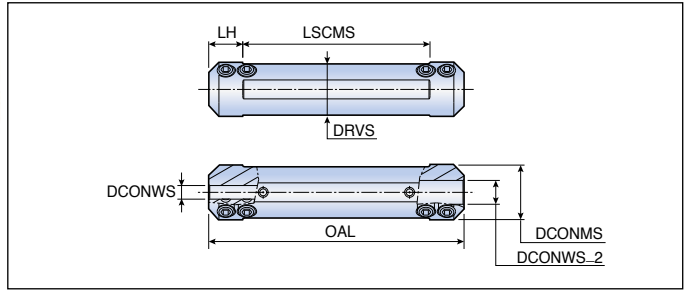

Designation	Dimension (mm)						
	DCONMS	DCONWS	DCONWS_2	OAL	LH	LSCMS	DRVS
MINSL 12-4-4	12	4	4	75	13	49	10.3
14-4-4	14	4	4	75	13	49	12
16-4-7	16	4	7	75	10	55	15
19-4-7	19.05	4	7	89	10	69	17.2
20-4-7	20	4	7	90	10	70	18
22-4-7	22	4	7	90	10	70	20
25-4-7	25	4	7	90	10	70	23.4

Spare parts

Designation	Set screw	Wrench		
MINSL 12	SS M5x0.8x4-MG	L-W 2.5		
MINSL 14/16/19/20/22/25	SS M5x0.8x6-MG	L-W 2.5		

MINS ...-L100C



Sleeves for direct connection for coolant

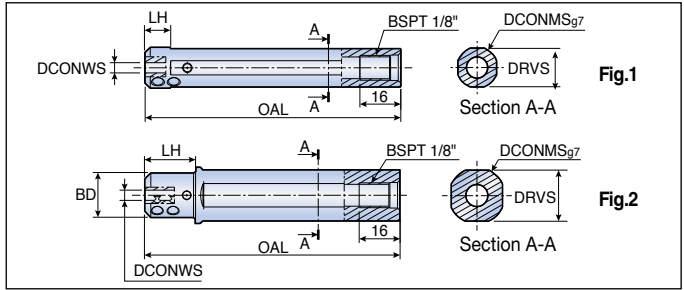

Designation	Dimension (mm)						Fig.
	DCONMS	DCONWS	BD	OAL	LH	DRVS	
MINS 16-4-L100C	16	4	-	100	10	15	1
16-7-L100C	16	7	-	100	10	15	1
20-4-L100C	20	4	17.5	100	20	18	2
20-7-L100C	20	7	17.5	100	20	18	2
22-4-L100C	22	4	17.5	100	20	20	2
22-7-L100C	22	7	17.5	100	20	20	2
25-4-L100C	25	4	18	100	23	23	2
25-7-L100C	25	7	18	100	23	23	2

► All sleeves applicable for Citizen Swiss type machine

Spare parts

Designation	Set screw	Wrench		
MINS ...-L100C	SS M5x0.8x6-MG	L-W 2.5		

MINT R/L 04



Mini carbide bars for internal turning and chamfering

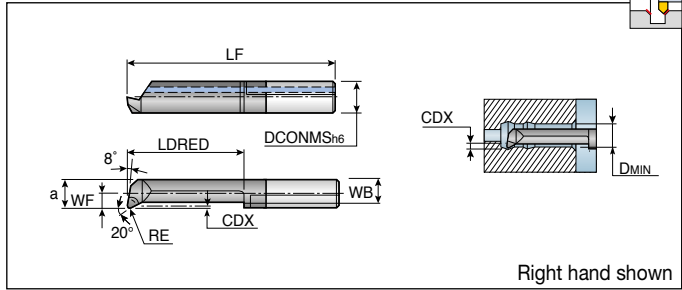

Designation	Dimension (mm)									R/L	Grade TT9030
	DCONMS	WF	a	WB	LF	LDRED	RE	CDX	DMIN		
MINTR04- 020004D006*	4.00	-	0.50	0.35	18.50	3.50	0.04	0.08	0.60	R	●
030004D006*	4.00	-	0.50	0.35	19.50	4.50	0.04	0.08	0.60	R	●
045005D010	4.00	-	0.90	0.70	21.00	6.00	0.05	0.10	1.00	R	●
065005D010	4.00	-	0.90	0.70	23.00	8.00	0.05	0.10	1.00	R	●
040005D020	4.00	-	1.70	1.45	20.50	5.50	0.05	0.10	2.00	R	●
090005D020	4.00	-	1.70	1.45	25.50	10.50	0.05	0.10	2.00	R	●
140005D020	4.00	-	1.70	1.45	30.50	15.50	0.05	0.10	2.00	R	●
090010D028	4.00	0.90	2.60	2.20	25.50	10.50	0.10	0.20	2.80	R	●
150010D028	4.00	0.90	2.60	2.20	31.50	16.50	0.10	0.20	2.80	R	●
190010D028	4.00	0.90	2.60	2.20	35.50	20.50	0.10	0.20	2.80	R	●
090010D040	4.00	1.50	3.50	2.90	25.50	10.50	0.10	0.30	4.00	R	●
150010D040	4.00	1.50	3.50	2.90	31.50	16.50	0.10	0.30	4.00	R	●
190010D040	4.00	1.50	3.50	2.90	35.50	20.50	0.10	0.30	4.00	R	●
230010D040	4.00	1.50	3.50	2.90	39.50	24.50	0.10	0.30	4.00	R	●
270010D040	4.00	1.50	3.50	2.90	43.50	28.50	0.10	0.30	4.00	R	●
MINTL04- 090010D028	4.00	0.90	2.60	2.20	25.50	10.50	0.10	0.20	2.80	L	●
150010D028	4.00	0.90	2.60	2.20	31.50	16.50	0.10	0.20	2.80	L	●
190010D028	4.00	0.90	2.60	2.20	35.50	20.50	0.10	0.20	2.80	L	●
090010D040	4.00	1.50	3.50	2.90	25.50	10.50	0.10	0.30	4.00	L	●
150010D040	4.00	1.50	3.50	2.90	31.50	16.50	0.10	0.30	4.00	L	●
190010D040	4.00	1.50	3.50	2.90	35.50	20.50	0.10	0.30	4.00	L	●

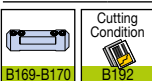

*: Max D.O.C: 0.01 - 0.03, max feed 0.01mm/rev

●: Standard items

Mini carbide bars for internal turning and chamfering

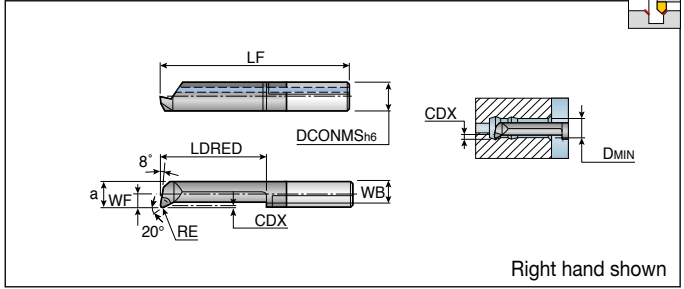

Designation	Dimension (mm)									R/L	Grade TT9030
	DCONMS	WF	a	WB	LF	LDRED	RE	CDX	DMIN		
MINTR07-090015D050	7.00	0.90	4.40	3.65	25.00	10.00	0.15	0.50	5.00	R	●
140015D050	7.00	0.90	4.40	3.65	30.00	15.00	0.15	0.50	5.00	R	●
190015D050	7.00	0.90	4.40	3.65	35.00	20.00	0.15	0.50	5.00	R	●
240015D050	7.00	0.90	4.40	3.65	40.00	25.00	0.15	0.50	5.00	R	●
290015D050	7.00	0.90	4.40	3.65	45.00	30.00	0.15	0.50	5.00	R	●
340015D050	7.00	0.90	4.40	3.65	50.00	35.00	0.15	0.50	5.00	R	●
140015D060	7.00	1.80	5.30	4.40	30.00	15.00	0.15	0.50	6.00	R	●
210015D060	7.00	1.80	5.30	4.40	37.00	22.00	0.15	0.50	6.00	R	●
240015D060	7.00	1.80	5.30	4.40	40.00	25.00	0.15	0.50	6.00	R	●
290015D060	7.00	1.80	5.30	4.40	45.00	30.00	0.15	0.50	6.00	R	●
340015D060	7.00	1.80	5.30	4.40	50.00	35.00	0.15	0.50	6.00	R	●
410015D060	7.00	1.80	5.30	4.40	57.00	42.00	0.15	0.50	6.00	R	●
190015D068	7.00	2.80	6.30	5.40	35.00	20.00	0.15	0.60	6.80	R	●
240015D068	7.00	2.80	6.30	5.40	40.00	25.00	0.15	0.60	6.80	R	●
290015D068	7.00	2.80	6.30	5.40	45.00	30.00	0.15	0.60	6.80	R	●
340015D070	7.00	2.80	6.30	5.40	50.00	35.00	0.15	0.60	7.00	R	●
390015D070	7.00	2.80	6.30	5.40	55.00	40.00	0.15	0.60	7.00	R	●
440015D070	7.00	2.80	6.30	5.40	60.00	45.00	0.15	0.60	7.00	R	●
490015D070	7.00	2.80	6.30	5.40	65.00	50.00	0.15	0.60	7.00	R	●
MINTL07-090015D050	7.00	0.90	4.40	3.65	25.00	10.00	0.15	0.50	5.00	L	●
140015D050	7.00	0.90	4.40	3.65	30.00	15.00	0.15	0.50	5.00	L	●
190015D050	7.00	0.90	4.40	3.65	35.00	20.00	0.15	0.50	5.00	L	●
240015D050	7.00	0.90	4.40	3.65	40.00	25.00	0.15	0.50	5.00	L	●
290015D050	7.00	0.90	4.40	3.65	45.00	30.00	0.15	0.50	5.00	L	●
140015D060	7.00	1.80	5.30	4.40	30.00	15.00	0.15	0.50	6.00	L	●
210015D060	7.00	1.80	5.30	4.40	37.00	22.00	0.15	0.50	6.00	L	●
240015D060	7.00	1.80	5.30	4.40	40.00	25.00	0.15	0.50	6.00	L	●
290015D060	7.00	1.80	5.30	4.40	45.00	30.00	0.15	0.50	6.00	L	●
190015D068	7.00	2.80	6.30	5.40	35.00	20.00	0.15	0.60	6.80	L	●
290015D068	7.00	2.80	6.30	5.40	45.00	30.00	0.15	0.60	6.80	L	●
340015D070	7.00	2.80	6.30	5.40	50.00	35.00	0.15	0.60	7.00	L	●

● Standard items

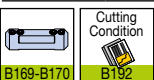

MINP R 04/07



Mini carbide bars for internal turning and profiling

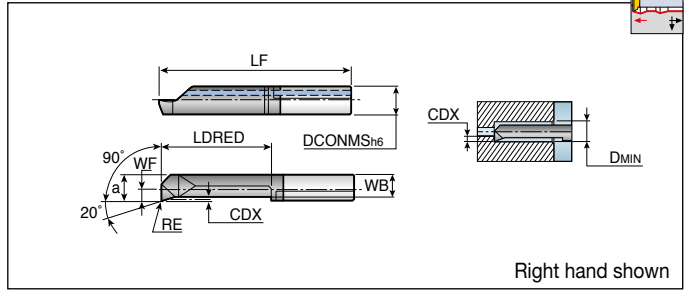

Designation	Dimension (mm)									R/L	Grade
	DCONMS	WF	a	WB	LF	LDRED	RE	CDX	DMIN		
MINPR04-090010D028	4.00	0.90	2.60	2.20	25.50	10.50	0.10	0.20	2.80	R	●
150010D028	4.00	0.90	2.60	2.20	31.50	16.50	0.10	0.20	2.80	R	●
090010D040	4.00	1.50	3.50	2.90	25.50	10.50	0.10	0.30	4.00	R	●
150010D040	4.00	1.50	3.50	2.90	31.50	16.50	0.10	0.30	4.00	R	●
MINPR07-140015D050	7.00	0.90	4.40	3.65	30.00	15.00	0.15	0.50	5.00	R	●
190015D050	7.00	0.90	4.40	3.65	35.00	20.00	0.15	0.50	5.00	R	●

●: Standard items

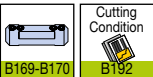

MINC R 07



Mini carbide bars for internal turning and 45° chamfering

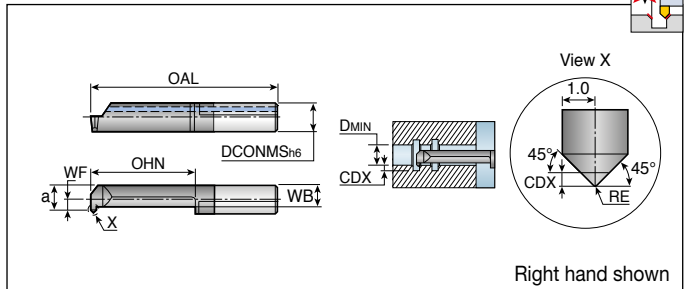

Designation	Dimension (mm)									R/L	Grade
	DCONMS	WF	a	WB	OAL	OHN	RE	CDX	DMIN		
MINCR07-140020D050	7.00	0.90	4.40	3.20	30.00	15.00	0.20	0.70	5.00	R	●
190020D050	7.00	0.90	4.40	3.20	35.00	20.00	0.20	0.70	5.00	R	●
190020D068	7.00	2.80	6.30	3.80	35.00	20.00	0.20	0.70	6.80	R	●

●: Standard items

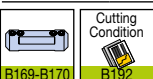

MING R/L 07



Mini carbide bars for grooving and turning

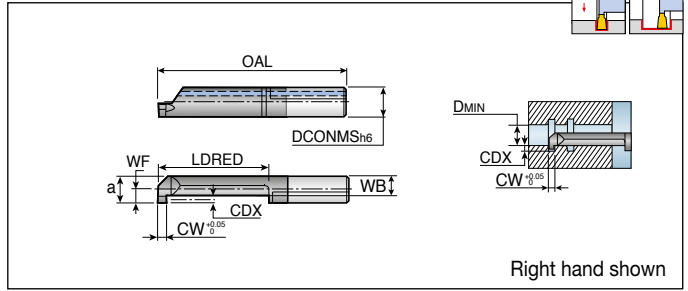

Designation	Dimension (mm)									R/L	Grade TT9030
	DCONMS	CW	WF	a	WB	OAL	LDRED	CDX	DMIN		
MINGR07- 090100D050	7.00	1.00	0.90	4.40	3.00	25.00	10.00	1.00	5.00	R	●
140100D050	7.00	1.00	0.90	4.40	3.00	30.00	15.00	1.00	5.00	R	●
090150D050	7.00	1.50	0.90	4.40	3.00	25.00	10.00	1.00	5.00	R	●
140150D050	7.00	1.50	0.90	4.40	3.00	30.00	15.00	1.00	5.00	R	●
090200D050	7.00	2.00	0.90	4.40	3.00	25.00	10.00	1.00	5.00	R	●
190200D050	7.00	2.00	0.90	4.40	3.00	35.00	20.00	1.00	5.00	R	●
090100D060	7.00	1.00	1.80	5.30	3.10	25.00	10.00	1.80	6.00	R	●
140100D060	7.00	1.00	1.80	5.30	3.10	30.00	15.00	1.80	6.00	R	●
210100D060	7.00	1.00	1.80	5.30	3.10	37.00	22.00	1.80	6.00	R	●
290100D060	7.00	1.00	1.80	5.30	3.10	45.00	30.00	1.80	6.00	R	●
090150D060	7.00	1.50	1.80	5.30	3.10	25.00	10.00	1.80	6.00	R	●
140150D060	7.00	1.50	1.80	5.30	3.10	30.00	15.00	1.80	6.00	R	●
210150D060	7.00	1.50	1.80	5.30	3.10	37.00	22.00	1.80	6.00	R	●
240150D060	7.00	1.50	1.80	5.30	3.10	40.00	25.00	1.80	6.00	R	●
290150D060	7.00	1.50	1.80	5.30	3.10	45.00	30.00	1.80	6.00	R	●
090200D060	7.00	2.00	1.80	5.30	3.10	25.00	10.00	1.80	6.00	R	●
140200D060	7.00	2.00	1.80	5.30	3.10	30.00	15.00	1.80	6.00	R	●
210200D060	7.00	2.00	1.80	5.30	3.10	37.00	22.00	1.80	6.00	R	●
240200D060	7.00	2.00	1.80	5.30	3.10	40.00	25.00	1.80	6.00	R	●
290200D060	7.00	2.00	1.80	5.30	3.10	45.00	30.00	1.80	6.00	R	●
090100D068	7.00	1.00	2.70	6.20	3.30	25.00	10.00	2.50	6.80	R	●
140100D068	7.00	1.00	2.70	6.20	3.30	30.00	15.00	2.50	6.80	R	●
210100D068	7.00	1.00	2.70	6.20	3.30	37.00	22.00	2.50	6.80	R	●
090150D068	7.00	1.50	2.70	6.20	3.30	25.00	10.00	2.50	6.80	R	●
140150D068	7.00	1.50	2.70	6.20	3.30	30.00	15.00	2.50	6.80	R	●
210150D068	7.00	1.50	2.70	6.20	3.30	37.00	22.00	2.50	6.80	R	●
290150D068	7.00	1.50	2.70	6.20	3.30	45.00	30.00	2.50	6.80	R	●
090200D068	7.00	2.00	2.70	6.20	3.30	25.00	10.00	2.50	6.80	R	●
140200D068	7.00	2.00	2.70	6.20	3.30	30.00	15.00	2.50	6.80	R	●
210200D068	7.00	2.00	2.70	6.20	3.30	37.00	22.00	2.50	6.80	R	●
290200D068	7.00	2.00	2.70	6.20	3.30	45.00	29.00	2.50	6.80	R	●
MINGL07- 090100D060	7.00	1.00	1.80	5.30	3.10	25.00	10.00	1.80	6.00	L	●
090150D060	7.00	1.50	1.80	5.30	3.10	25.00	10.00	1.80	6.00	L	●
140200D068	7.00	2.00	2.70	6.20	3.30	30.00	15.00	2.50	6.80	L	●

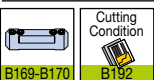

▶ The corner radius is less than 0.1mm

●: Standard items

MINF R/L 07



Mini carbide bars for deep face grooving

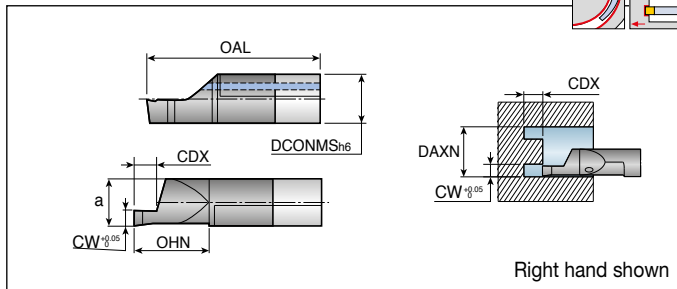
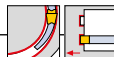

Designation	Dimension (mm)							R/L	Grade TT9030
	DCONMS	CW	a	OAL	OHN	CDX	DAXN		
MINFR07- 110100D060	7.00	1.00	5.20	27.00	11.00	1.50	6.00	R	●
110100D080	7.00	1.00	5.90	27.00	12.00	1.50	8.00	R	●
110150D060	7.00	1.50	5.20	27.00	11.00	2.00	6.00	R	●
110150D080	7.00	1.50	5.90	27.00	12.00	2.50	8.00	R	●
110200D060	7.00	2.00	5.20	27.00	11.00	3.00	6.00	R	●
200200D080	7.00	2.00	5.90	36.00	21.00	3.00	8.00	R	●
210150D080	7.00	1.50	5.90	37.00	22.00	2.50	8.00	R	●
110200D080	7.00	2.00	5.90	27.00	12.00	3.00	8.00	R	●
210200D080	7.00	2.00	5.90	37.00	22.00	3.00	8.00	R	●
110250D080	7.00	2.50	5.90	27.00	12.00	3.50	8.00	R	●
210250D080	7.00	2.50	5.90	37.00	22.00	3.50	8.00	R	●
110300D080	7.00	3.00	5.90	27.00	12.00	3.50	8.00	R	●
210300D080	7.00	3.00	5.90	37.00	22.00	3.50	8.00	R	●
300200D080	7.00	2.00	5.90	46.00	31.00	3.00	8.00	R	●
300300D080	7.00	3.00	5.90	46.00	31.00	3.50	8.00	R	●
MINFL07- 210150D080	7.00	1.50	5.90	37.00	22.00	2.50	8.00	L	●
300200D080	7.00	2.00	5.90	46.00	31.00	3.00	8.00	L	●

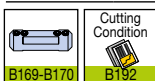

▶ The corner radius is less than 0.1mm

●: Standard items

MINS R 07



Mini carbide bars for grooving along shaft

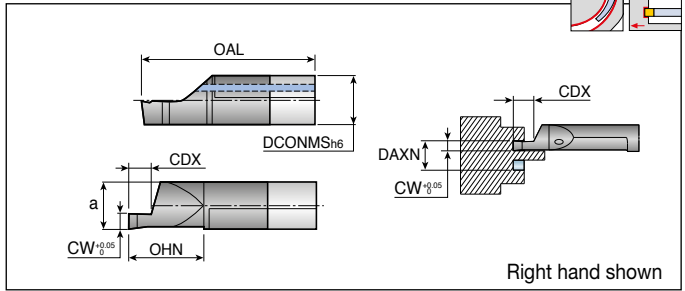

Designation	Dimension (mm)							R/L	Grade TT9030
	DCONMS	CW	a	OAL	OHN	CDX	DAXN		
MINSR07 -200200D060	7.00	2.00	5.20	36.00	21.00	4.00	6.00	R	●

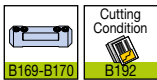

▶ The corner radius is less than 0.1mm

●: Standard items

MINR R 07



Mini carbide bars, full radius for internal turning and profiling

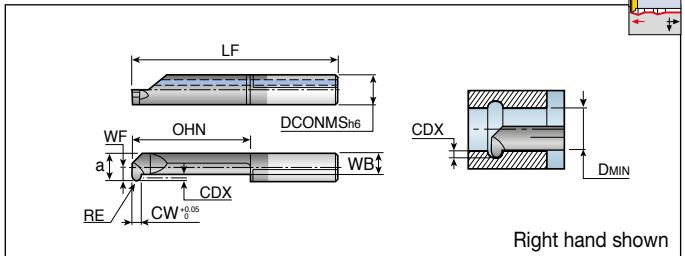

Designation	Dimension (mm)										R/L	Grade TT9030
	DCONMS	CW	WF	a	WB	RE	LF	OHN	CDX	DMIN		
MINRR07-190050D050	7.00	1.00	0.90	4.40	3.10	0.50	35.00	20.00	1.00	5.00	R	●
240050D060	7.00	1.00	1.80	5.30	3.20	0.50	40.00	25.00	1.80	6.00	R	●
290050D068	7.00	1.00	2.80	6.30	3.55	0.50	45.00	30.00	2.50	6.80	R	●

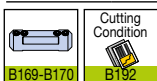

●: Standard items

MINI R 04/07



Mini carbide bars for ISO internal thread turning

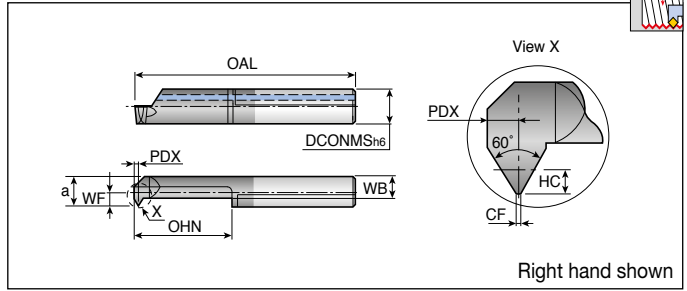

Designation	Dimension (mm)											Grade
	DCONMS	Pitch	HC	CF	PDX	WF	a	WB	OAL	OHN	DMIN	
MINIR04- 14005D040	4.00	0.50	0.30	0.06	0.35	1.50	3.50	2.40	30.00	15.00	4.00	●
MINIR07- 14005D050	7.00	0.50	0.30	0.06	0.35	0.90	4.40	3.30	30.00	15.00	5.00	●
140075D050	7.00	0.75	0.40	0.09	0.45	0.90	4.40	3.30	30.00	15.00	5.00	●
140100D048	7.00	1.00	0.60	0.12	0.55	0.90	4.40	3.30	30.00	15.00	4.80	●
140100D060	7.00	1.00	0.60	0.12	0.55	1.80	5.30	3.40	30.00	15.00	6.00	●
140125D060	7.00	1.25	0.70	0.15	0.65	1.80	5.30	3.40	30.00	15.00	6.00	●
140150D060	7.00	1.50	0.80	0.18	0.75	1.80	5.30	3.40	30.00	15.00	6.00	●
140150D070	7.00	1.50	0.80	0.18	0.75	2.80	6.30	3.80	30.00	15.00	7.00	●

●: Standard items

MINBR 04/07



Mini carbide bars for internal back turning

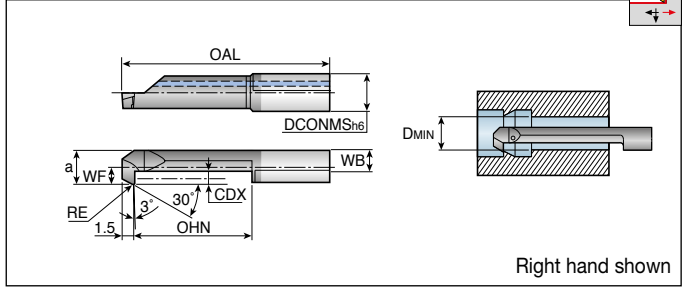

Designation	Dimension (mm)									R/L	Grade TT9030
	DCONMS	WF	a	WB	OAL	OHN	RE	CDX	DMIN		
MINBR04-140020D030	4.00	0.60	2.60	1.80	30.00	15.00	0.20	0.50	3.00	R	●
190020D030	4.00	0.60	2.60	1.80	35.00	20.00	0.20	0.50	3.00	R	●
140015D040	4.00	1.50	3.50	2.40	30.00	15.00	0.15	0.80	4.00	R	●
240015D040	4.00	1.50	3.50	2.40	40.00	25.00	0.15	0.80	4.00	R	●
MINBR07-190020D050	7.00	0.90	4.40	3.10	35.00	20.00	0.20	1.00	5.00	R	●
290020D050	7.00	0.90	4.40	3.10	45.00	30.00	0.20	1.00	5.00	R	●
190020D060	7.00	1.80	5.30	3.20	35.00	20.00	0.20	1.80	6.00	R	●
290020D060	7.00	1.80	5.30	3.20	45.00	30.00	0.20	1.80	6.00	R	●
190020D070	7.00	2.80	6.30	3.50	35.00	20.00	0.20	2.50	7.00	R	●
290020D070	7.00	2.80	6.30	3.50	45.00	30.00	0.20	2.50	7.00	R	●

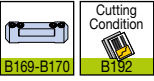

● Standard items

TDIT **3.20** - **0.00** - **0.25** - **TT8020**

1

2

3

4

5

6

1 Main style of insert

T type: Chip breaker
G type: Non-chip breaker

2 Insert width

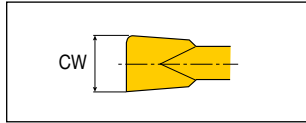

3 Corner radius

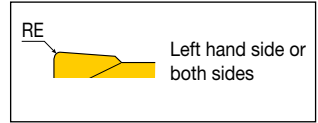

4 Corner radius

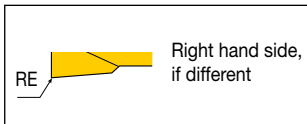

5 Additional codes

6 Grades

Special profile inserts

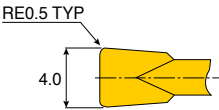
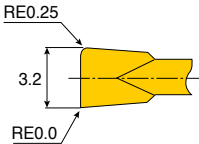
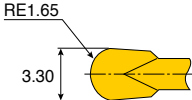
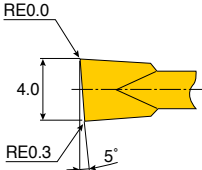
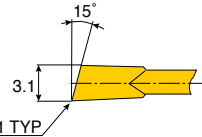
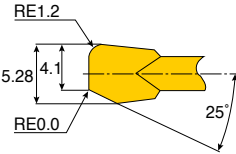
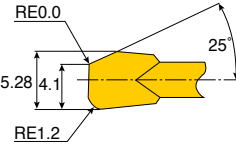

Tailor-made inserts are available upon request

Shape	Designation	Remarks
 <p>RE0.5 TYP 4.0</p>	TDT 4.00-0.50	Symmetrical type
 <p>RE0.25 3.2 RE0.0</p>	TDIT 3.20-0.00-0.25	Non-symmetrical type
 <p>RE1.65 3.30</p>	TDT 3.30-1.65	Full-R type
 <p>RE0.0 4.0 RE0.3 5°</p>	TDT 4.00-0.30-5RA	L: Chamfer on left hand side R: Chamfer on right hand side
 <p>15° 3.1 RE0.1 TYP</p>	TDT 3.10-0.10-15LA	
 <p>RE1.2 5.28 4.1 RE0.0 25°</p>	TDG 5.28-1.20-R25A	
 <p>RE0.0 5.28 4.1 RE1.2 25°</p>	TDT 5.28-1.20-L25A	

Shape	Designation	Remarks
	TDG 4.40-1.82-29A	L: Chamfer on left hand side R: Chamfer on right hand side
	TDT 4.40-1.50-30A	
	TDT 5.28-2.05-45R25L	
	TDG 4.40-0.15-60A	
	TDG 5.40-0.10-30R50L	
	TDT 3.90-4.00	
	TDT 1.90-T3.5C	
	TDT 1.90-0.30-4.20T	

Shape	Designation
	TDG 1.98-T4.5C
	TDFT 3.80E-0.25
	TDIT 2.60-1.30
The others	Available upon customer's request

Heavy Industry

Tailor-made

Designation	Dimension (mm)	Remarks
XNMR 401416-HD		
XNGT 332-GV		

► Specific dimensions

External holder

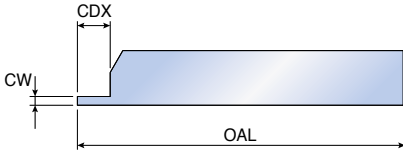

Right handed shown

Internal holder

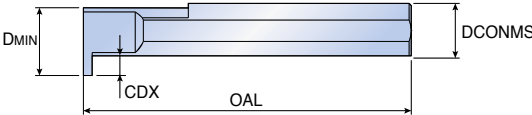

Right handed shown

Facing holder

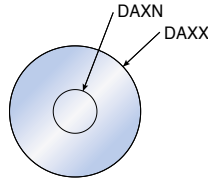
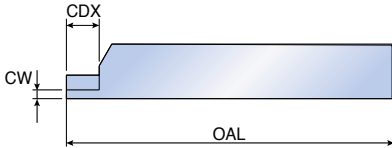

Right handed shown

External holder

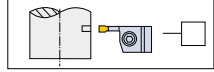

Facing holder

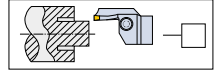
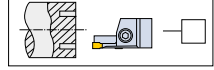

RN type

Internal holder

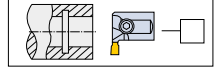

Holder handed

- Right handed
- Left handed

Insert

- Grade: _____
- Chip breaker type: _____

Quantity

• _____ pcs

Workpieces

- Part: _____
- Material: _____
- Hardness: _____

Comment

- Customer: _____
- Address : _____
- Telephone : _____
- E-mail : _____

- Contact: _____
- Fax : _____

Technical Data

► Screw torque

SH type

Designation	Thread	Length	Torx / Hexa	Tightening Torque
SH M4x0.7x16	M4	20	Hexa 3mm	3.5 Nm
SH M4x0.7x20-MO	M4	23.9	Hexa 3 mm	3.5 Nm
SH M5x0.8x10	M5	15	Hexa 4 mm	5.5 Nm
SH M5x0.8x12	M5	17	Hexa 4 mm	5.5 Nm
SH M5x0.8x16	M5	21	Hexa 4 mm	5.5 Nm
SH M5x0.8x20	M5	25	Hexa 4 mm	5.5 Nm
SH M5x0.8x25	M5	30	Hexa 4 mm	5.5 Nm
SH M6x1.0x16	M6	22	Hexa 5 mm	8.0 Nm
SH M6x1.0x20	M6	26	Hexa 5 mm	8.0 Nm
SH M6x1.0x25	M6	31	Hexa 5 mm	8.0 Nm
SH M6X1.0X30	M6	36	Hexa 5mm	8.0 Nm
SH M6x1.0x40	M6	46	Hexa 5 mm	8.0 Nm
SH M8x1.25x20	M8	28	Hexa 6 mm	12.0 Nm
SH M8x1.25x25	M8	33	Hexa 6 mm	12.0 Nm

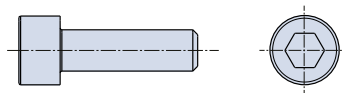

TS type

Designation	Thread	Length	Torx / Hexa	Tightening Torque
TS 22052I/HG	M2.2	5.2	Torx 7	0.9 Nm
TS 25075I/HG	M2.5	7.5	Torx 8	1.2 Nm
TS 35110I	M3.5	11	Torx 15	3.0 Nm
TS 35110IL	M3.5	11	Torx 15	3.0 Nm
TS 40093I	M4	9	Torx 15	3.5 Nm
TS 40097I	M4	9.7	Torx 15	3.5 Nm
TS 40A100	M4	10	Torx 15	3.5 Nm
TS 40A100L	M4	10	Torx 15	3.5 Nm
TS 40A115I	M4	11.5	Torx 15	3.5 Nm
TS 40B100I	M4	10	Torx 15	3.5 Nm
TS 45120I	M4.5	12	Torx 20	5.0 Nm
TS 50125I	M5	12.5	Torx 10/20	5.5 Nm
TS 50125IL	M5	12.5	Torx 10/20	5.5 Nm
TS 50170I-IC	M5	17	Torx 15	3.5 Nm
TS 50170IL-IC	M5	17	Torx 15	3.5 Nm
TS 60190I	M6	19	Hexa 4 mm	6.0 Nm
CSTB-4SD	M4	8	Torx 8	3.5 Nm

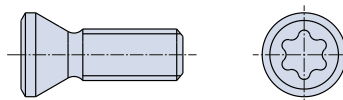

SS type

Designation	Thread	Length	Torx / Hexa	Tightening Torque
SS M5-24145	M5	5.1	Hexa 2.5mm	2.5 Nm

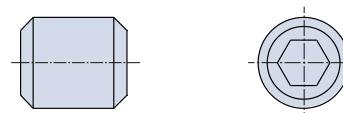

BH type

Designation	Thread	Length	Torx / Hexa	Tightening Torque
BH M6X1X16	M6	24.2	Hexa 4.0mm	5.5 Nm

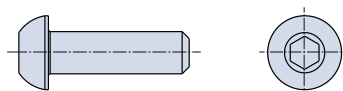

Recommended Cutting Conditions

Parting

ISO	Material	Condition	Tensile strength (N/mm ²)	Hardness HB	Material No.	Cutting speed Vc(m/min)					
						TT9080	TT4430	TT7220 TT8020	K10		
P	Non-alloy steel, cast steel, free cutting steel	<0.25%C	Annealed	420	125	1	140-250	120-220	80-120		
		>=0.25%C	Annealed	650	190	2	130-220	100-190	80-110		
		<0.55%C	Quenched and tempered	850	250	3	90-200	80-170	70-90		
		>=0.55%C	Annealed	750	220	4	100-220	80-190	70-100		
			Quenched and tempered	1000	300	5	70-170	70-140	40-70		
	Low alloy steel and cast steel (Less than 5% of alloying elements)	Annealed		600	200	6	90-120	80-110	70-100		
				930	275	7	80-170	80-140	50-70		
		Quenched and tempered		1000	300	8	70-130	70-110	40-60		
				1200	350	9	50-120	50-100	30-50		
	High alloy steel, cast steel and tool steel	Annealed		680	200	10	60-140	60-120	50-80		
Quenched and tempered			1100	325	11	50-70	40-60	30-60			
M	Stainless steel and cast steel	Ferritic / martensitic		680	200	12	70-170	60-150	60-120		
		Martensitic		820	240	13	60-150	60-120	60-90		
		Austenitic		600	180	14	90-180	80-150	60-90		
K	Gray cast iron (GG)	Ferritic			160	15	150-260			60-80	
		Pearlitic			250	16	130-190			50-70	
	Cast iron nodular (GGG)	Ferritic			180	17	140-230			70-100	
		Pearlitic			260	18	110-180			70-90	
	Malleable cast iron	Ferritic			130	19	170-270			60-85	
		Pearlitic			230	20	140-230			45-75	
N	Aluminum - Wrought alloy	Not cureable			60	21					
		Cured			100	22					
	Aluminum-cast, alloyed	<=12% Si	Not cureable			75	23				
			Cured			90	24				
		>12% Si	High temp.			130	25				
	Copper alloys	>1% Pb	Free cutting			110	26				
			Brass			90	27				
		Electrolitic copper			100	28					
	Non-metallic	Duroplastics, fiber plastics			70 Shore D	29					
		Hard rubber			55 Shore D	30					
S	High temp. alloys	Fe based	Annealed			200	31	40-70			35-50
			Cured			280	32	30-50			25-40
		Ni or Co based	Annealed			250	33	30-40			20-30
			Cured			350	34	15-25			15-20
			Cast			320	35	15-30			15-20
	Titanium, Ti alloys	Pure		Rm 400	190	36	90-190				150-200
		Alpha+beta alloys cured		Rm 1050	310	37	30-60				50-80
H	Hardened steel	Hardened			55HRC	38					
		Hardened			60HRC	39					
	Chilled cast iron	Cast			400	40					
	Cast iron nodular	Hardened			55HRC	41					

► For more information of material groups, see the materials & grades "material conversion table"

■ Steel
 ■ Stainless steel
 ■ Cast iron
 ■ Nonferrous
 ■ High temp. alloys
 ■ Hardened steel

Recommended Cutting Conditions

Grooving and Turning

ISO	Material	Condition	Tensile strength (N/mm ²)	Hardness HB	Material No.	Cutting speed Vc(m/min)		
							TD1020	
P	Non-alloy steel, cast steel, free cutting steel	<0.25%C	Annealed	420	125	1		
		>=0.25%C	Annealed	650	190	2		
		<0.55%C	Quenched and tempered	850	250	3		
		>=0.55%C	Annealed	750	220	4		
			Quenched and tempered	1000	300	5		
	Low alloy steel and cast steel (Less than 5% of alloying elements)		Annealed		600	200	6	
					930	275	7	
			Quenched and tempered		1000	300	8	
					1200	350	9	
	High alloy steel, cast steel and tool steel		Annealed	680	200	10		
Quenched and tempered			1100	325	11			
M	Stainless steel and cast steel	Ferritic / martensitic	680	200	12			
		Martensitic	820	240	13			
		Austenitic	600	180	14			
K	Gray cast iron (GG)	Ferritic		160	15			
		Pearlitic		250	16			
	Cast iron nodular (GGG)	Ferritic		180	17			
		Pearlitic		260	18			
	Malleable cast iron	Ferritic		130	19			
		Pearlitic		230	20			
N	Aluminum - Wrought alloy	Not cureable		60	21	150-2500		
		Cured		100	22	150-2500		
	Aluminum-cast, alloyed	<=12% Si	Not cureable		75	23	150-2500	
			Cured		90	24	150-2500	
	Copper alloys	>12% Si	High temp.		130	25	330-800	
		>1% Pb	Free cutting		110	26		
	Non-metallic		Brass		90	27	330-800	
			Electrolitic copper		100	28	190-400	
	S	High temp. alloys	Fe based	Annealed		200	31	
				Cured		280	32	
Ni or Co based			Annealed		250	33		
			Cured		350	34		
Cast					320	35		
Titanium, Ti alloys		Pure	Rm 400	190	36			
		Alpha+beta alloys cured	Rm 1050	310	37			
H	Hardened steel	Hardened		55HRC	38			
		Hardened		60HRC	39			
	Chilled cast iron	Cast		400	40			
	Cast iron nodular	Hardened		55HRC	41			

► For more information of material groups, see the materials & grades "material conversion table"

■ Steel
 ■ Stainless steel
 ■ Cast iron
 ■ Nonferrous
 ■ High temp. alloys
 ■ Hardened steel

Recommended Cutting Conditions

Grooving and Turning

Cutting speed Vc(m/min)									
TB2015	CT3000	TT7505	TT6080	TT3010	TT5100	TT9080	TT4430	TT7220 TT8020	K10
	100-210				110-220	100-200	90-180	80-150	
	100-200				110-200	100-180	90-160	100-150	
	80-180				90-180	80-160	80-140	70-130	
	80-180				90-180	80-160	80-140	70-120	
	70-150				80-150	70-130	70-110	60-100	
	100-180				110-180	100-160	90-140	80-120	
	90-180				90-180	80-160	80-150	70-130	
	80-170				90-170	80-150	80-130	70-110	
	80-150				90-150	80-130	80-120	60-100	
	90-130				100-150	90-130	90-120	80-110	
	50-80				60-90	50-80	50-70	40-60	
	80-170				90-190	80-170	80-150	70-130	
	80-150				90-170	80-150	80-130	70-110	
	80-170				90-190	80-170	80-150	70-130	
		150-270	110-250						70-100
		120-170	90-140						50-90
		150-250	120-230						70-100
		120-200	90-180						60-90
		120-200	90-180						60-120
		100-180	80-150						50-80
									300-800
									230-310
									280-830
									200-510
									130-300
									120-200
									90-150
					40-60	40-60	30-50	30-40	30-40
					30-50	25-45	20-40	20-30	20-40
					30-40	25-35	20-30	15-25	20-30
					25-35	20-25	15-20	15-20	15-20
					25-35	20-25	15-20	15-20	15-20
					140-180	150-190	130-170	100-150	80-100
					40-80	50-80	40-70	40-60	15-30
90-110		30-50	25-45						20-40
80-100		30-50	25-35						20-30
180-200		30-50	25-45						20-50
90-110		30-50	25-45						20-40

Recommended Cutting Conditions

Face grooving and Internal grooving

ISO	Material	Condition	Tensile strength (N/mm ²)	Hardness HB	Material No.	Cutting speed Vc(m/min)		
						TT7505		
P	Non-alloy steel, cast steel, free cutting steel	<0.25%C	Annealed	420	125	1		
		>=0.25%C	Annealed	650	190	2		
		<0.55%C	Quenched and tempered	850	250	3		
		>=0.55%C	Annealed	750	220	4		
			Quenched and tempered	1000	300	5		
	Low alloy steel and cast steel (Less than 5% of alloying elements)		Annealed		600	200	6	
					930	275	7	
			Quenched and tempered		1000	300	8	
					1200	350	9	
	High alloy steel, cast steel and tool steel		Annealed	680	200	10		
Quenched and tempered			1100	325	11			
M	Stainless steel and cast steel	Ferritic / martensitic	680	200	12			
		Martensitic	820	240	13			
		Austenitic	600	180	14			
K	Gray cast iron (GG)	Ferritic		160	15	90-140		
		Pearlitic		250	16	80-120		
	Cast iron nodular (GGG)	Ferritic		180	17	90-130		
		Pearlitic		260	18	80-110		
	Malleable cast iron	Ferritic		130	19	80-130		
		Pearlitic		230	20	60-100		
N	Aluminum - Wrought alloy	Not cureable		60	21			
		Cured		100	22			
	Aluminum-cast, alloyed	<=12% Si	Not cureable		75	23		
			Cured		90	24		
		>12% Si	High temp.		130	25		
	Copper alloys	>1% Pb	Free cutting		110	26		
			Brass		90	27		
			Electrolytic copper		100	28		
	Non-metallic		Duroplastics, fiber plastics		70 Shore D	29		
			Hard rubber		55 Shore D	30		
S	High temp. alloys	Fe based	Annealed		200	31		
			Cured		280	32		
		Ni or Co based	Annealed		250	33		
			Cured		350	34		
	Titanium, Ti alloys		Pure	Rm 400	190	36		
			Alpha+beta alloys cured	Rm 1050	310	37		
H	Hardened steel	Hardened		55HRC	38	15-25		
		Hardened		60HRC	39	15-25		
	Chilled cast iron	Cast		400	40	15-25		
	Cast iron nodular	Hardened		55HRC	41	15-25		

► For more information of material groups, see the materials & grades "material conversion table"

■ Steel
 ■ Stainless steel
 ■ Cast iron
 ■ Nonferrous
 ■ High temp. alloys
 ■ Hardened steel

Recommended Cutting Conditions

Face grooving and Internal grooving

Cutting speed Vc(m/min)							
TT6080	TT3010	TT5100	TT9080	TT4430	TT7220 TT8020	K10	
		110-160	100-150	100-130	80-110		
		70-110	60-100	60-90	50-80		
		70-120	60-110	60-100	50-90		
		70-120	60-110	60-100	40-70		
		80-120	70-110	70-100	40-60		
		70-100	60-90	60-80	30-50		
		70-100	60-90	60-80	30-50		
		60-90	50-80	50-70	30-40		
		60-140	50-130	50-110	40-80		
		50-140	40-130	40-110	30-80		
70-120						40-60	
60-100						40-60	
70-110						40-60	
60-90						30-50	
60-110						20-40	
50-90						20-40	
						100-300	
						100-300	
						100-300	
						100-300	
						80-200	
						80-150	
						60-100	
	30-50	30-50	20-40	20-30	15-25		
	25-40	20-40	15-30	15-25	10-15		
	25-35	20-30	15-20	15-20	10-15		
	20-30	20-30	15-20	15-20	10-15		
	20-30	20-30	15-20	15-20	10-15		
	100-130	100-130	90-120	80-100	60-80		
	30-60	30-60	20-50	20-40	15-30		
15-20						15-20	
15-20						15-20	
15-25						15-25	
15-25						15-25	

Recommended Cutting Conditions

T-CLAMP ceramic insert

Material		Grooving	Turning
P	High hardened steel	Vc (m/min)	250-350
		F (mm/rev)	0.08-0.20
K	Cast iron	600-800	600-800
		0.1-0.2	0.1-0.24

► Above condition is adapted to TDT 4E-0.4T CE AB30

TOP-MICRO carbide bars







Cutting speed Vc(m/min)	Feed (mm/rev)		
	Turning / Back turning	Grooving	Face grooving
P 30-150	0.01-0.08	0.01-0.05	0.01-0.04
M 30-130			
K 30-150			
N 50-200			
S 10-50			

THREAD MAKING

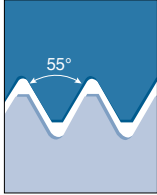
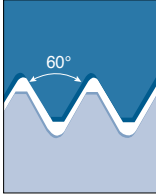
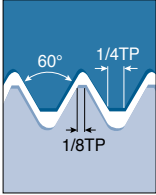
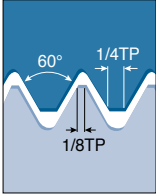

Tool Selection Guide

Threading inserts

Thread		T-THREAD			
		55° thread	60° thread	Metric ISO	American UN
					
Pages		C19	C20	C21 - C25	C26 - C30
Pitch		thread / inch	mm (thread / inch)	mm	thread / inch
Application		General use for 55° thread forms for wide range of pitches	General use for 60° thread forms for wide range of pitches	General usage for all industries	General usage for all industries
 M - type	ER	●	●	●	●
	IR	●	●	●	●
 Regular type	ER/IR	●	●	●	●
	EL/IL	●	●	●	●
 B - type	ER	●	●	●	●
	IR	●	●	●	●
 U - type	IRL	●	●	●	●
	EIRL	●	●		
	ERL			●	
 Multi-tooth type	ER			●	●
	IR			●	●

ER: External right hand

ERL: External right / left hand

EL: External left hand

IRL: Internal Right / left hand

IR: Internal right hand

EIRL: External / internal right / left hand

IL: Internal left hand

Tool Selection Guide







Threading inserts

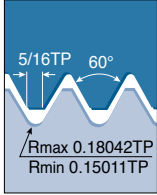
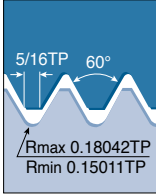
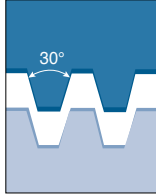
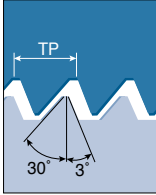

Whitworth	NPT	NPTF	BSPT	STUB ACME	ACME
C31 - C34	C35 - C36	C37	C38	C39	C40
thread / inch	thread / inch	thread / inch	thread / inch	thread / inch	thread / inch
General industries. Pipe fittings and couplings	Steam, gas and water pipes	Steam, gas and water pipes. Dry seal	55° form for steam, gas and water pipes	Shallow ACME profile for motion transmission	Motion transmission. Feed screws
•	•		•		
•	•		•		
•	•	•	•	•	•
•	•		•	•	•
•	•		•		
•	•		•		
					•
					•
•	•				
•	•				

Tool Selection Guide

Threading inserts

		T-THREAD			
		UNJ	MJ	Trapez DIN 103	Sagengengewinde DIN 513
Thread					
Pages		C41 - C42	C43	C44	C46
Pitch		thread / inch	mm	mm	mm
Application		Aviation and aerospace industry	Aviation and aerospace industry	Motion transmission. Feed screws	For high force in one direction
 M - type	ER				
	IR				
 Regular type	ER/IR	●	●	●	●
	EL/IL	●		●	●
 B - type	ER				
	IR	●			
 U - type	ER/IR				●
	EL/IL				●
	ERL/IRL			●	
 Multi-tooth type	ER				
	IR				

ER: External right hand

ERL: External right / left hand

EL: External left hand

IRL: Internal Right / left hand

IR: Internal right hand

EIRL: External / internal right / left hand

IL: Internal left hand

Tool Selection Guide

Threading inserts

T-THREAD					
American buttress	Round DIN 405	API round	API	Buttress casing	Extreme line casing
C47	C48	C49 - C50	C50	C51	C51
thread / inch	thread / inch	thread / inch	thread / inch	thread / inch	thread / inch
For high force in one direction	Pipe coupling in fire fighting, chemical and food industries	60° thread with large radius in the oil and gas industry	60° thread form for pipe connections in the oil and gas industry	Tube and casings in the oil and gas industry	Tube and casings in the oil and gas industry
	•				
	•				
•	•	•	•	•	•
•	•	•	•		
•					

Grades

Thread making grades

Grades	ISO	Characteristics & applications
TT7010 PVD coated	P05 – P25 K05 – K25	<ul style="list-style-type: none"> • General machining of steel and cast iron
TT8010 PVD coated	P30 – P50 M30 – M50 S30 – S50	<ul style="list-style-type: none"> • Toughest grade in threading product line • For a wide range of threading on low carbon steel & low carbon alloy steel • Medium to low speed threading of stainless steel and exotic materials
TT9030 PVD coated	P20 – P40 M20 – M40 S20 – S40	<ul style="list-style-type: none"> • General machining of steel • General machining of stainless steel • General machining of heat-resistant alloy
P30 Carbide	P25 – P35	<ul style="list-style-type: none"> • General machining of steel

T-THREAD

Thread Turning





1 Clamping system

S - Screw clamping

2 Application

E - External
I - Internal

3 Hand of tool

R - Right-hand
L - Left-hand

4 Shank size

External toolholders
Shank: HxB

2020: 20x20 mm

Internal toolholders
Neck diameter

0025: Neck diameter 25 mm

5 Tool length

	mm
D	- 60
F	- 80
H	- 100
K	- 125
L	- 140
M	- 150
P	- 170
R	- 200
S	- 250
T	- 300
U	- 350
V	- 400

6 Insert size

INSL (mm)	IC
06	3.97 mm = 5/32"
08	4.76 mm = 3/16"
08U	4.76 mm = 3/16"
11	6.35 mm = 1/4"
16	9.52 mm = 3/8"
22	12.70 mm = 1/2"
22U	12.70 mm = 1/2"
27	15.88 mm = 5/8"
27U	15.88 mm = 5/8"

7 Optional specifications

U - For U-type inserts
B - Bore for coolant
C - Carbide shank
D - Drop head
G - Gang tool
AD - Short type
SP - Special

External threading toolholders

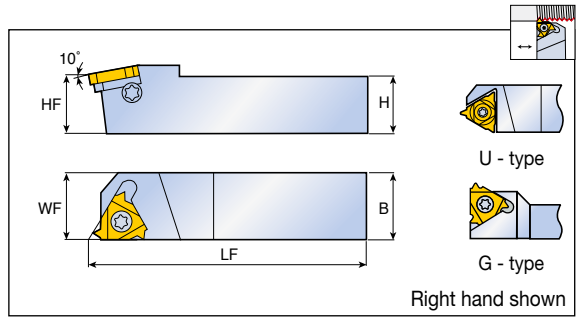

Designation	Dimension (mm)					Insert ⁽²⁾
	H	HF	B	LF	WF	
SER 0808 H11 ⁽¹⁾	8	8	8	100	11	11 ER...
1616 K16G	16	16	16	125	21.7	16 ER...
4040 R27	40	40	40	200	40	27 ER...
SER/L 1010 H11 ⁽¹⁾	10	10	10	100	11	11 ER/L...
1212 F16	12	12	12	80	16	16 ER/L...
1212 X16	12	12	12	120	12	16 ER/L...
1616 H16	16	16	16	100	16	16 ER/L...
2020-16-AD	20	20	20	67	25	16 ER/L...
2020 K16	20	20	20	125	20	16 ER/L...
2525 M16	25	25	25	150	25	16 ER/L...
3232 P16	32	32	32	170	32	16 ER/L...
2525 M22	25	25	25	150	25	22 ER/L...
3232 P22	32	32	32	170	32	22 ER/L...
4040 R22	40	40	40	200	40	22 ER/L...
2525 M22U	25	25	25	150	28	22 UERL...
3232 P22U	32	32	32	170	32	22 UERL...
4040 R22U	40	40	40	200	40	22 UERL...
2525 M27	25	25	25	150	25	27 ER/L...
3232 P27	32	32	32	170	32	27 ER/L...
2525 M27U	25	25	25	150	32	27 UERL...
3232 P27U	32	32	32	170	32	27 UERL...
4040 R27U	40	40	40	200	40	27 UERL...

- ▶ ⁽¹⁾ Toolholders without anvil
- ▶ ⁽²⁾ Right hand inserts (ER) for right hand tools (SER)
- ▶ All Toolholders are made with 1.5° helix angle
- ▶ For multi-tooth inserts use anvils AE16M, AE22M, AE27M

Spare parts

Designation	Insert screw	Anvil screw	Anvil ext. right	Anvil ext. left	Torx wrench	
SER/L...11	S11	A16	AE16	AI16	T-8/5	
SER...16	S16	A16	AE16		T-10/5	
SEL...16	S16	A16		AI16	T-10/5	
SER...22(22U)	S22	A22	AE22(AE22U)		T-20/5	
SEL...22(22U)	S22	A22		AI22(AI22U)	T-20/5	
SER...27(27U)	TS40	A27	AE27(AE27U)		TK40	
SEL...27(27U)	TS40	A27		AI27(AI27U)	TK40	

Internal threading toolholders

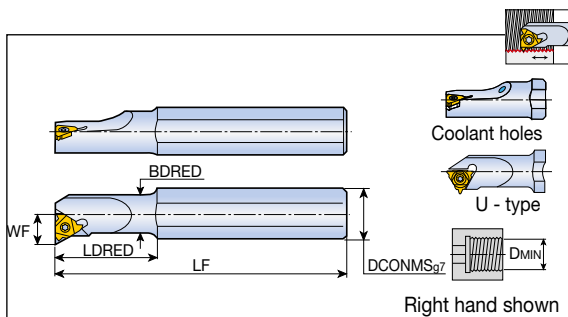

Designation	Dimension (mm)						Coolant hole	Insert ⁽²⁾
	DCONMS	BDRED	LF	LDRED	DMIN	WF		
SIR/L 0005 H06 ⁽¹⁾	12	5.1	100	12	6.4	4.3	X	06 IR/L...
0007 K08 ⁽¹⁾	16	6.6	125	18	9.0	5.3	X	08 IR/L...
0008 K08U ⁽¹⁾	16	7.4	125	21	9.0	6.4	X	08 UIRL...
0010 H11 ⁽¹⁾	10	10	100	-	12	7.4	X	11 IR/L...
SIR 0010 H11B ⁽¹⁾	10	10	100	-	12	7.4	●	11 IR...
SIR/L 0010 K11 ⁽¹⁾	16	10	125	25	12	6.5	X	11 IR/L...
0010 K11B ⁽¹⁾	16	10	125	25	12	7.4	●	11 IR/L...
0013 L11 ⁽¹⁾	16	13	140	32	15	8.9	X	11 IR/L...
0013 M16 ⁽¹⁾	16	13	150	32	16	10.0	X	16 IR/L...
0013 M16B ⁽¹⁾	16	13	150	32	16	10.2	●	16 IR/L...
0016 P16 ⁽¹⁾	20	16	170	40	19	11.4	X	16 IR/L...
0016 P16B ⁽¹⁾	20	16	170	40	19	11.7	●	16 IR/L...
0020-16-AD	20	20	80	-	24	13.7	X	16 IR/L...
0020 P16	20	20	170	-	24	13.4	X	16 IR/L...
0020 P16B	20	20	170	-	24	13.7	●	16 IR/L...
0025-16-AD	25	25	120	-	29	16.3	X	16 IR/L...
0025 R16	25	25	200	-	29	16.3	X	16 IR/L...
0025 R16B	25	25	200	-	29	16.2	●	16 IR/L...
0032 S16	32	32	250	-	36	19.6	X	16 IR/L...
0040 T16	40	40	300	-	44	23.8	X	16 IR/L...
0050 U16	50	50	350	-	54	28.7	X	16 IR/L...
0020 P22 ⁽¹⁾	20	20	170	-	24	15.6	X	22 IR/L...
0025 R22	25	25	200	-	29	17.2	X	22 IR/L...
0025 R22B	25	25	200	-	29	18.1	●	22 IR/L...
0032 S22	32	32	250	-	38	21.5	X	22 IR/L...
0040 T22	40	40	300	-	46	25.8	X	22 IR/L...
0050 U22	50	50	350	-	56	30.6	X	22 IR/L...
0032 S22U	32	32	250	-	38	25.5	X	22 UIRL...
0040 T22U	40	40	300	-	46	29.5	X	22 UIRL...
0032 S27	32	32	250	-	40	22.4	X	27 IR/L...
0040 T27	40	40	300	-	48	26.4	X	27 IR/L...
0050 U27	50	50	350	-	58	31.4	X	27 IR/L...
0060 V27	60	60	400	-	68	36.4	X	27 IR/L...

- ▶ ⁽¹⁾ Toolholders without anvil
- ▶ ⁽²⁾ Right hand inserts (IR) for right hand tools (SIR)
- ▶ For multi-tooth inserts use anvils AI16M, AI22M, AI27M
- ▶ All Toolholders are made with 1.5° helix angle

Internal threading toolholders

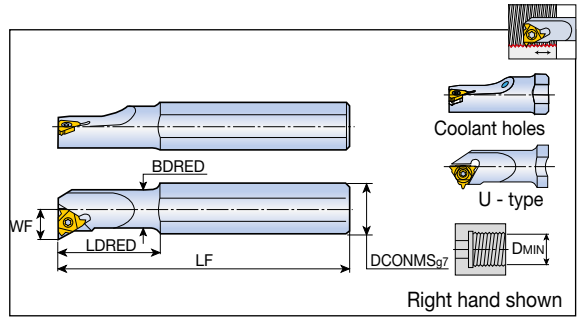

Designation	Dimension (mm)						Coolant hole	Insert ⁽²⁾
	DCONMS	BDRED	LF	LDRED	DMIN	WF		
SIR/L 0032 S27U	32	32	250	-	40	24.7	x	27 UIRL...
0040 T27U	40	40	300	-	48	29.4	x	27 UIRL...
0050 U27U	50	50	350	-	58	34.3	x	27 UIRL...
0060 V27U	60	60	400	-	68	39.3	x	27 UIRL...

- ▶ ⁽²⁾ Right hand inserts (IR) for right hand tools (SIR)
- ▶ For multi-tooth inserts use anvils AI16M, AI22M, AI27M
- ▶ All Toolholders are made with 1.5° helix angle

Spare parts

Designation	Insert screw	Anvil screw	Anvil int. left	Anvil int. right	Torx wrench	
SIR/L...06	TS 20038I					T-6/5
SIR/L...08	TS 20054I					T-6/5
SIR/L...11	S11					T-8/5
SIR/L 0013...16	S16S					T-10/5
SIR/L 0016...16	S16S					T-10/5
SIR...16	S16	A16		A16		T-10/5
SIL...16	S16	A16	AE16			T-10/5
SIR/L 0020...22	S22S					T-20/5
SIR...22	S22	A22		A122		T-20/5
SIR...22U	S22	A22		A122U		T-20/5
SIL...22	S22	A22	AE22			T-20/5
SIL...22U	S22	A22	AE22U			T-20/5
SIR...27	TS40	A27		A127		TK40
SIR...27U	TS40	A27		A127U		TK40
SIL...27	TS40	A27	AE27			TK40
SIL...27U	TS40	A27	AE27U			TK40

Sleeve holders for external threading

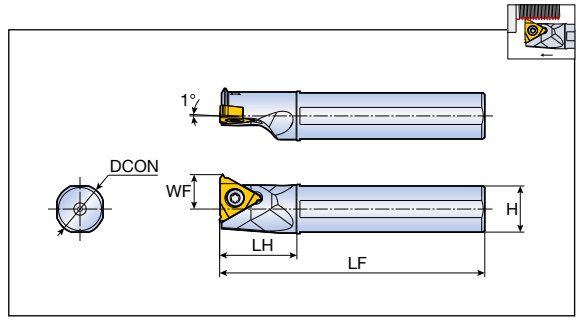

Designation	Dimension (mm)					Insert
	DCON	H	LF	LH	WF	
TMS- 16F SEL 16	16	15	85	25	11	16 ER...
19G SEL 16	19.05	18	90	30	12.5	
19X SEL 16	19.05	18	120	30	12.5	
20G SEL 16	20	19	90	30	13	
20X SEL 16	20	19	120	30	13	
25H SEL 16	25	24	100	30	15.5	
254X SEL 16	25.4	24	120	30	15.7	

► Use left hand toolholders (L) with right hand insert (ER)

Spare parts

Designation	Screw	Wrench		
TMS-SEL	S16	T-10/5		

QH-SIR/L

Screw type threading heads

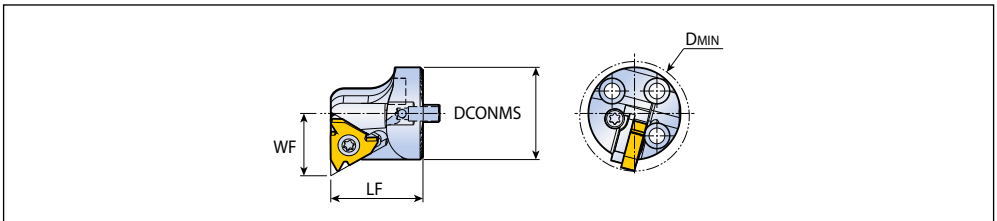

Designation	Dimension (mm)				Coolant hole	Insert
	DCONMS	LF	WF	DMIN		
QH25-SIR/L-16	25	26	16.2	29	●	16 IR/L...
QH32-SIR/L-16	32	27	19.7	36	●	
QH40-SIR/L-16	40	30	23.7	44	●	
QH32-SIR/L-22	32	32	21.6	38	●	22 IR/L...
QH40-SIR/L-22	40	38	25.6	46	●	

► Please refer to C17 page for spare parts

Anti-vibration shanks for boring

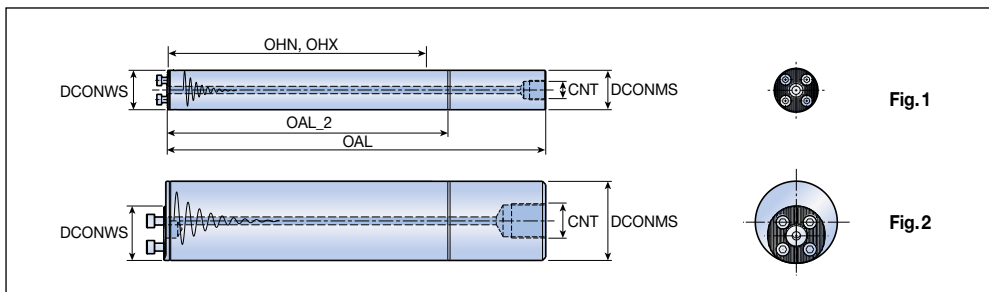

Designation	Dimension (mm)					Coolant hole	Fig.
	DCONMS	DCONWS	OAL	OHX	CNT		
QS25A-7D	25	25	257.5	155	G 1/4	●	1
QS25A-10D	25	25	332.5	230	G 1/4	●	1
QS25E-12D⁽¹⁾	25	25	380.0	280	G 1/8	●	1
QS25E-14D⁽¹⁾	25	25	430.0	330	G 1/8	●	1
QS32A-7D	32	32	323.0	192	G 3/8	●	1
QS32A-10D	32	32	419.0	288	G 3/8	●	1
QS32E-12D⁽¹⁾	32	32	480.0	352	G 1/4	●	1
QS32E-14D⁽¹⁾	32	32	544.0	416	G 1/4	●	1
QS40A-7D	40	40	411.0	251	G 1/2	●	1
QS40A-10D	40	40	531.0	368	G 1/2	●	1
QS40E-12D⁽¹⁾	40	40	608.0	448	G 3/8	●	1
QS40E-14D⁽¹⁾	40	40	688.0	528	G 3/8	●	1
QS50A-7D	50	40	523.0	318	G 1/2	●	2
QS50A-10D	50	40	673.0	468	G 1/2	●	2
QS50E-12D⁽¹⁾	50	40	768.0	568	G 1/2	●	2
QS50E-14D⁽¹⁾	50	40	868.0	668	G 1/2	●	2
QS60A-7D	60	40	633.0	388	G 3/4	●	2
QS60A-10D	60	40	813.0	568	G 3/4	●	2
QS60E-12D⁽¹⁾	60	40	920.0	688	G 3/4	●	2
QS60E-14D⁽¹⁾	60	40	1040.0	808	G 3/4	●	2

► OHX: Maximum overhang

► ⁽¹⁾ Carbide shank

Spare parts

Designation	Insert screw	Anvil screw	Anvil int. left Anvil ext. right	Anvil int. right Anvil ext. left	Torx wrench	Screw	Wrench
QH SIR-16	S16	A16	-	A16	T-10/5		
QH SIL-16	S16	A16	AE16	-	T-10/5		
QH SIR-22	S22	A22	-	A122	T-20/5		
QH SIL-22	S22	A22	AE22	-	T-20/5		
QS25						SH M4x0.7X12	L-W 3
QS32						SH M5x0.8X12	L-W 4
QS40/50/60						SH M6x1X16	L-W 5

16 E R M 1.50 ISO 2M TT9030
1 2 3 4 5 6 7 8

1 Insert size

INSL (mm)	IC
06	3.97 mm = 5/32"
08	4.76 mm = 3/16"
11	6.35 mm = 1/4"
16	9.52 mm = 3/8"
22	12.70 mm = 1/2"
27	15.88 mm = 5/8"

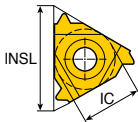

2 Application

E - External
I - Internal
UE - U-type, external
UI - U-type, Internal
UEI - U-type, external and internal

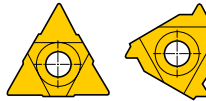

U-type Regular type

3 Hand of tool

R - Right-hand
L - Left-hand
RL - Right and left-hand

4 Type

M - With a chip breaker
B - Peripherally ground & chip breaker
 - No indication regular type

5 Pitch

Full profile

Value by number

0.35 - 9.0 mm (Thread pitch)

72 - 2 TPI (Threads per inch)

Partial profile

Range by letter

	mm (Thread pitch)	TPI (Threads per inch)
A	0.5 - 1.5 mm	48 - 16
AG	0.5 - 3.0 mm	48 - 8
G	1.75 - 3.0 mm	14 - 8
N	3.5 - 5.0 mm	7 - 5
Q	5.5 - 6.0 mm	4.5 - 4
U	5.5 - 9.0 mm	4.5 - 2.75

6 Thread standard

60 - Partial profile 60°
55 - Partial profile 55°
ISO - ISO metric
UN - American UN
W - Whitworth
BSPT - British BSPT
RND - Round DIN 405
TR - Trapeze DIN 103
ACME - ACME
STACME - Stub ACME
ABUT - American buttress
UNJ - UNJ
MJ - MJ ISO 5855
NPT - NPT
API RD - API round
BUT - API buttress casing
API - API
EL - Extreme line casing
SAGE - Sagengewinde DIN 513

7 No. of teeth (Optional)

2M - 2 teeth
3M - 3 teeth

8 Grades

Coated
 TT7010
 TT8010
 TT9030

Uncoated
 P30

Partial Profile 55°



External & internal

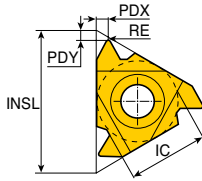



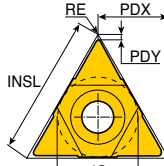

External right hand shown
(Internal left hand)

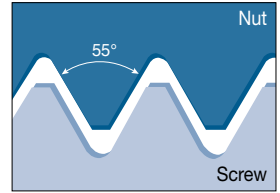

U-type



• Application: General industry

Insert	Designation	Pitch		Dimension (mm)					Coated			Uncoated
		TP (mm)	TPI	IC	INSL	RE	PDY	PDX	TT7010	TT9030	TT8010	P30
External  Regular  B/M	11ER/L A 55	0.5-1.5	48-16	6.35	11	0.05	0.8	0.9	•	•		
	16ER/L A 55	0.5-1.5	48-16	9.52	16	0.05	0.8	0.9		•		•
	16ER/L AG 55	0.5-3.0	48-8	9.52	16	0.05	1.2	1.7	•	•	•	
	16ERB AG 55	0.5-3.0	48-8	9.52	16	0.05	1.2	1.7		•		
	16ERM AG 55	0.5-3.0	48-8	9.52	16	0.07	1.2	1.7	•	•		•
	16ER/L G 55	1.75-3.0	14-8	9.52	16	0.20	1.2	1.7	•	•		
	16ERB G 55	1.75-3.0	14-8	9.52	16	0.20	1.2	1.7		•		
	16ERM G 55	1.75-3.0	14-8	9.52	16	0.23	1.2	1.7	•	•		
	22ER/L N 55	3.5-5.0	7-5	12.70	22	0.42	1.7	2.5	•	•		
27ER Q 55	5.5-6.0	4.5-4	15.88	27	0.60	2.0	2.9		•			
Internal  Regular  B/M	06IR/L A 55	0.5-1.25	48-20	3.97	6	0.05	0.5	0.6			•	
	08IR/L A 55	0.5-1.5	48-16	4.76	8	0.05	0.6	0.7		•	•	
	11IR/L A 55	0.5-1.5	48-16	6.35	11	0.05	0.8	0.9	•	•	•	
	16IR A 55	0.5-1.5	48-16	9.52	16	0.05	0.8	0.9		•		
	16IR/L AG 55	0.5-3.0	48-8	9.52	16	0.05	1.2	1.7	•	•		
	16IRB AG 55	0.5-3.0	48-8	9.52	16	0.05	1.2	1.7		•		
	16IRM AG 55	0.5-3.0	48-8	9.52	16	0.05	1.2	1.7	•	•		
	16IR/L G 55	1.75-3.0	14-8	9.52	16	0.20	1.2	1.7	•	•		
	16IRB G 55	1.75-3.0	14-8	9.52	16	0.20	1.2	1.7		•		
	16IRM G 55	1.75-3.0	14-8	9.52	16	0.20	1.2	1.7	•	•		
 U	22IR/L N 55	3.5-5.0	7-5	12.70	22	0.42	1.7	2.5	•	•		•
	27IR/L Q 55	5.5-6.0	4.5-4	15.88	27	0.60	2.0	2.9		•		
	08UIRL U 55	1.75-2.0	14-11	4.76	8	0.10	0.9	4.0			•	
	22UEIRL U 55	5.5-8.0	4.5-3.25	12.70	22	0.60	0.9	11.0	•			

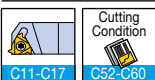

▶ ERB / ERM / IRB / IRM with pressed chip breaker

•: Standard items

Partial Profile 60°



External & internal

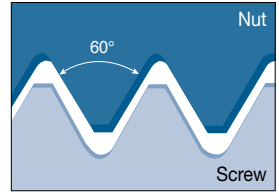
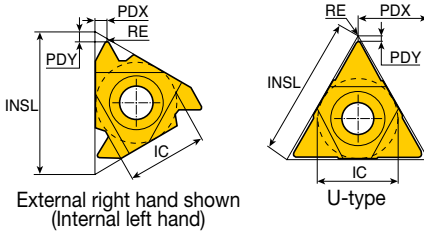

• Application: General industry

Insert	Designation	Pitch		Dimension (mm)					Coated			Uncoated
		TP (mm)	TPI	IC	INSL	RE	PDY	PDX	TT7010	TT9030	TT8010	P30
	11ER/L A 60	0.5-1.5	48-16	6.35	11	0.05	0.8	0.9		●		
	16ER/L A 60	0.5-1.5	48-16	9.52	16	0.05	0.8	0.9	●	●	●	
	16ERB A 60	0.5-1.5	48-16	9.52	16	0.05	0.8	0.9		●		
	16ERM A 60	0.5-1.5	48-16	9.52	16	0.05	0.8	0.9	●	●		●
	16ER/L AG 60	0.5-3.0	48-8	9.52	16	0.06	1.2	1.7	●	●	●	●
	16ERB AG 60	0.5-3.0	48-8	9.52	16	0.05	1.2	1.7		●		
	16ERM AG 60	0.5-3.0	48-8	9.52	16	0.06	1.2	1.7	●	●		●
	16ER/L G 60	1.75-3.0	14-8	9.52	16	0.17	1.2	1.7	●	●	●	
	16ERB G 60	1.75-3.0	14-8	9.52	16	0.17	1.2	1.7		●		
	16ERM G 60	1.75-3.0	14-8	9.52	16	0.17	1.2	1.7	●	●		
	22ER/L N 60	3.5-5.0	7-5	12.70	22	0.32	1.7	2.5	●	●	●	
	22ERM N 60	3.5-5.0	7-5	12.70	22	0.32	1.7	2.5	●	●		●
27ER/L Q 60	5.5-6.0	4.5-4	15.88	27	0.63	2.1	3.1	●	●		●	
	06IR/L A 60	0.5-1.25	48-20	3.97	6	0.05	0.6	0.6			●	
	06IRM A 60	0.5-1.25	48-20	3.97	6	0.05	0.5	0.6			●	
	08IR/L A 60	0.5-1.5	48-16	4.76	8	0.05	0.6	0.7			●	
	08IRM A 60	0.5-1.5	48-16	4.76	8	0.05	0.6	0.7			●	
	11IR/L A 60	0.5-1.5	48-16	6.35	11	0.05	0.8	0.9	●	●	●	
	11IRM A 60	0.5-1.5	48-16	6.35	11	0.05	0.7	0.9	●	●		
	16IR/L A 60	0.5-1.5	48-16	9.52	16	0.05	0.8	0.9	●	●	●	●
	16IRB A 60	0.5-1.5	48-16	9.52	16	0.05	0.8	0.9		●		
	16IRM A 60	0.5-1.5	48-16	9.52	16	0.05	0.8	0.9	●	●		
	16IR/L AG 60	0.5-3.0	48-8	9.52	16	0.05	1.2	1.7	●	●	●	●
	16IRB AG 60	0.5-3.0	48-8	9.52	16	0.05	1.2	1.7		●		
	16IRM AG 60	0.5-3.0	48-8	9.52	16	0.05	1.2	1.7	●	●		●
16IR/L G 60	1.75-3.0	14-8	9.52	16	0.12	1.2	1.7		●	●		
16IRB G 60	1.75-3.0	14-8	9.52	16	0.12	1.2	1.7		●			
16IRM G 60	1.75-3.0	14-8	9.52	16	0.10	1.2	1.7	●	●		●	
22IR/L N 60	3.5-5.0	7-5	12.70	22	0.22	1.7	2.5	●	●			
22IRM N 60	3.5-5.0	7-5	12.70	22	0.19	1.7	2.5	●	●		●	
27IR/L Q 60	5.5-6.0	4.5-4	15.88	27	0.31	2.1	3.1	●	●		●	
	08UIRL U 60	1.75-2.0	14-11	4.76	8	0.10	0.8	4.0			●	
	22UEIRL U 60	5.5-8.0	4.5-3.25	12.70	22	0.28	0.6	11.0	●	●		
	27UEIRL U 60	6.5-9.0	4-2.75	15.88	27	0.28	1.0	13.7	●			

▶ ERB / ERM / IRB / IRM with pressed chip breaker

●: Standard items

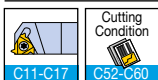

External ISO Metric

Full profile (DIN13 12-1986 class: 6G)

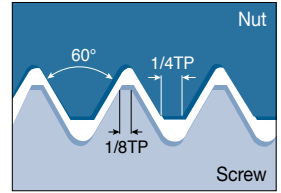
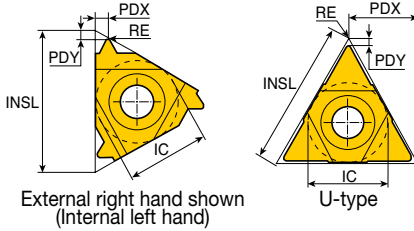

• Application: General industry

Insert	Designation	TP (mm)	Dimension (mm)					Coated			Uncoated
			IC	INSL	RE	PDY	PDX	TT7010	TT9030	TT8010	P30
External	11ER/L 0.35 ISO	0.35	6.35	11	0.04	0.8	0.4		•		
	11ER 0.40 ISO	0.40	6.35	11	0.04	0.7	0.4		•		
Regular	11ER 0.45 ISO	0.45	6.35	11	0.05	0.7	0.4			•	
	11ER/L 0.50 ISO	0.50	6.35	11	0.05	0.6	0.6	•	•		
	11ER 0.60 ISO	0.60	6.35	11	0.07	0.6	0.6		•		
	11ER 0.70 ISO	0.70	6.35	11	0.07	0.6	0.6		•		
	11ER/L 0.75 ISO	0.75	6.35	11	0.08	0.6	0.6		•		
	11ER 0.80 ISO	0.80	6.35	11	0.09	0.6	0.6		•		
	11ER/L 1.00 ISO	1.00	6.35	11	0.12	0.7	0.7		•		
	11ER 1.25 ISO	1.25	6.35	11	0.15	0.8	0.9				
	11ER/L 1.50 ISO	1.50	6.35	11	0.18	0.8	1.0	•	•		
	11ER 1.75 ISO	1.75	6.35	11	0.21	0.8	1.1	•			
B/M	16ER/L 0.35 ISO	0.35	9.52	16	0.04	0.8	0.4		•		
	16ER/L 0.40 ISO	0.40	9.52	16	0.04	0.7	0.4		•		
	16ER 0.45 ISO	0.45	9.52	16	0.05	0.7	0.4		•		
	16ER/L 0.50 ISO	0.50	9.52	16	0.04	0.6	0.6	•	•		
	16ERM 0.50 ISO	0.50	9.52	16	0.04	0.6	0.6		•		
	16ER 0.60 ISO	0.60	9.52	16	0.07	0.6	0.6		•		
	16ER/L 0.70 ISO	0.70	9.52	16	0.07	0.6	0.6	•	•		
	16ER/L 0.75 ISO	0.75	9.52	16	0.08	0.6	0.6	•	•		
	16ERM 0.75 ISO	0.75	9.52	16	0.08	0.6	0.6		•		
	16ER/L 0.80 ISO	0.80	9.52	16	0.09	0.6	0.6	•	•		
	16ERB 0.80 ISO	0.80	9.52	16	0.09	0.6	0.6		•		
	16ER/L 1.00 ISO	1.00	9.52	16	0.12	0.7	0.7	•	•	•	•
	16ERB 1.00 ISO	1.00	9.52	16	0.12	0.7	0.7		•		
	16ERM 1.00 ISO	1.00	9.52	16	0.11	0.7	0.7	•	•		•
	16ER/L 1.25 ISO	1.25	9.52	16	0.15	0.8	0.9	•	•		
	16ERB 1.25 ISO	1.25	9.52	16	0.15	0.8	0.9		•		
	16ERM 1.25 ISO	1.25	9.52	16	0.14	0.8	0.9	•	•		
	16ER/L 1.50 ISO	1.50	9.52	16	0.18	0.8	1.0	•	•	•	•
	16ERB 1.50 ISO	1.50	9.52	16	0.18	0.8	1.0		•		
	16ERM 1.50 ISO	1.50	9.52	16	0.19	0.8	1.0	•	•		•
	16ER/L 1.75 ISO	1.75	9.52	16	0.21	0.9	1.2	•	•	•	
	16ERB 1.75 ISO	1.75	9.52	16	0.21	0.9	1.2		•		
	16ERM 1.75 ISO	1.75	9.52	16	0.20	0.9	1.2	•	•		

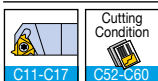

► ERB / ERM with pressed chip breaker



•: Standard items

External ISO Metric

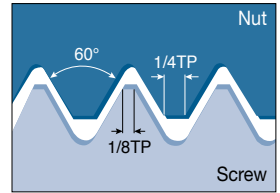
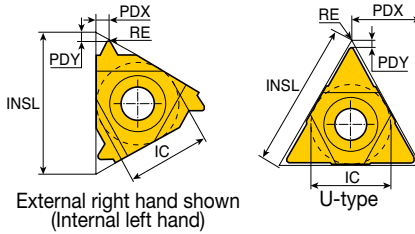
Full profile (DIN13 12-1986 class: 6G)



• Application: General industry

Insert	Designation	TP (mm)	Dimension (mm)					Coated			Uncoated
			IC	INSL	RE	PDY	PDX	TT7010	TT9030	TT8010	P30
 Regular	16ER/L 2.00 ISO	2.00	9.52	16	0.25	1.0	1.3	●	●	●	●
	16ERB 2.00 ISO	2.00	9.52	16	0.25	1.0	1.3		●		
	16ERM 2.00 ISO	2.00	9.52	16	0.24	1.0	1.3	●	●		
	16ER/L 2.50 ISO	2.50	9.52	16	0.31	1.1	1.5	●	●		●
	16ERB 2.50 ISO	2.50	9.52	16	0.31	1.1	1.5		●		
	16ERM 2.50 ISO	2.50	9.52	16	0.30	1.1	1.5	●	●		
	16ER/L 3.00 ISO	3.00	9.52	16	0.38	1.2	1.6	●	●	●	
	16ERB 3.00 ISO	3.00	9.52	16	0.38	1.2	1.6		●		
	16ERM 3.00 ISO	3.00	9.52	16	0.38	1.2	1.6	●	●		●
	22ER/L 3.50 ISO	3.50	12.70	22	0.44	1.6	2.3	●	●		
	22ERM 3.50 ISO	3.50	12.70	22	0.44	1.6	2.3		●		
	22ER/L 4.00 ISO	4.00	12.70	22	0.52	1.6	2.3	●	●		●
	22ERM 4.00 ISO	4.00	12.70	22	0.52	1.6	2.3		●		
	22ER/L 4.50 ISO	4.50	12.70	22	0.58	1.7	2.4	●	●		
	22ER/L 5.00 ISO	5.00	12.70	22	0.64	1.7	2.5	●	●		
22ER/L 6.00 ISO	6.00	12.70	22	0.78	2.0	2.7	●				
27ER 5.50 ISO	5.50	15.88	27	0.70	1.9	2.7		●			
27ER/L 6.00 ISO	6.00	15.88	27	0.78	2.0	2.9	●	●	●		
 U	22UERL 5.50 ISO	5.50	12.70	22	0.70	2.3	11.0	●			
	22UERL 6.00 ISO	6.00	12.70	22	0.78	2.6	11.0	●		●	
	27UERL 8.00 ISO	8.00	15.88	27	1.08	2.4	13.7		●		

▶ ERB / ERM with pressed chip breaker

●: Standard items

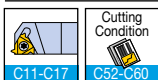

Internal ISO Metric

Full profile (DIN13 12-1986 class: 6H)

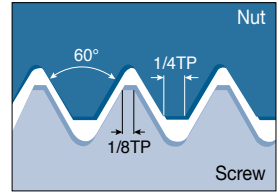
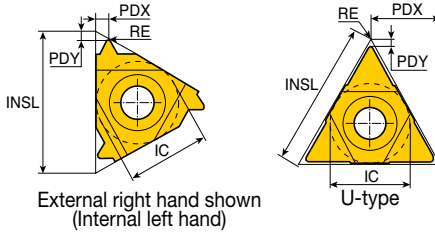

• Application: General industry

Insert	Designation	TP (mm)	Dimension (mm)					Coated			Uncoated
			IC	INSL	RE	PDY	PDX	TT7010	TT9030	TT8010	P30
Internal	06IR/L 0.50 ISO	0.50	3.97	6	0.04	0.6	0.4			•	
	06IR/L 0.75 ISO	0.75	3.97	6	0.06	0.6	0.5			•	
	06IR/L 1.00 ISO	1.00	3.97	6	0.05	0.6	0.6			•	
Regular	06IR/L 1.25 ISO	1.25	3.97	6	0.07	0.6	0.6			•	
	08IR/L 0.50 ISO	0.50	4.76	8	0.04	0.6	0.4			•	
	08IR 0.75 ISO	0.75	4.76	8	0.05	0.6	0.5			•	
B/M	08IR/L 1.00 ISO	1.00	4.76	8	0.07	0.6	0.6		•	•	
	08IR/L 1.25 ISO	1.25	4.76	8	0.09	0.7	0.7		•	•	
	08IR/L 1.50 ISO	1.50	4.76	8	0.10	0.6	0.7		•	•	
	08IR/L 1.75 ISO	1.75	4.76	8	0.15	0.6	0.9			•	
	11IR/L 0.35 ISO	0.35	6.35	11	0.04	0.8	0.3		•		
	11IR 0.40 ISO	0.40	6.35	11	0.03	0.8	0.4		•		
	11IR/L 0.50 ISO	0.50	6.35	11	0.04	0.8	0.6	•	•		
	11IRB 0.50 ISO	0.50	6.35	11	0.04	0.8	0.6		•		
	11IRM 0.50 ISO	0.50	6.35	11	0.04	0.3	0.4		•		
	11IR 0.70 ISO	0.70	6.35	11	0.05	0.6	0.6		•		
	11IR/L 0.75 ISO	0.75	6.35	11	0.05	0.6	0.6		•		
	11IRB 0.75 ISO	0.75	6.35	11	0.05	0.6	0.6		•		
	11IRM 0.75 ISO	0.75	6.35	11	0.06	0.3	0.5		•		
	11IR 0.80 ISO	0.80	6.35	11	0.04	0.6	0.6		•		
	11IR/L 1.00 ISO	1.00	6.35	11	0.07	0.6	0.7	•	•	•	•
	11IRB 1.00 ISO	1.00	6.35	11	0.07	0.6	0.6		•		
	11IRM 1.00 ISO	1.00	6.35	11	0.05	0.6	0.7		•		
11IR/L 1.25 ISO	1.25	6.35	11	0.09	0.8	0.8					
11IR/L 1.50 ISO	1.50	6.35	11	0.12	0.8	1.0	•	•	•	•	
11IRM 1.50 ISO	1.50	6.35	11	0.08	0.8	1.0	•	•			
11IR/L 1.75 ISO	1.75	6.35	11	0.12	0.8	1.0		•			
11IRB 1.75 ISO	1.75	6.35	11	0.12	0.8	1.0		•			
11IRM 1.75 ISO	1.75	6.35	11	0.15	0.6	0.9		•			
11IR/L 2.00 ISO	2.00	6.35	11	0.14	0.8	0.9	•	•	•		
11IRM 2.00 ISO	2.00	6.35	11	0.16	0.6	1.0		•			
16IR 0.35 ISO	0.35	9.52	16	0.02	0.6	0.3		•			
16IR/L 0.40 ISO	0.40	9.52	16	0.03	0.6	0.4		•			
16IR/L 0.50 ISO	0.50	9.52	16	0.04	0.6	0.6	•	•			
16IR 0.60 ISO	0.60	9.52	16	0.04	0.6	0.6		•			

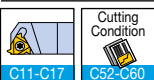

▶ IRB / IRM with pressed chip breaker

•: Standard items

Internal ISO Metric

Full profile (DIN13 12-1986 class: 6H)

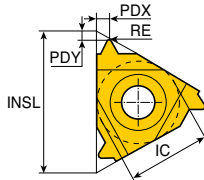



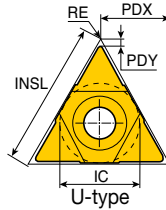

External right hand shown
(Internal left hand)

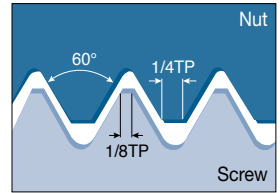

U-type



• Application: General industry

Insert	Designation	TP (mm)	Dimension (mm)					Coated			Uncoated
			IC	INSL	RE	PDY	PDX	TT7010	TT9030	TT8010	P30
 Internal  Regular  B/M	16IR/L 0.70 ISO	0.70	9.52	16	0.05	0.6	0.6	●	●		
	16IR/L 0.75 ISO	0.75	9.52	16	0.05	0.6	0.6	●	●		
	16IR/L 0.80 ISO	0.80	9.52	16	0.05	0.6	0.6	●			
	16IR/L 1.00 ISO	1.00	9.52	16	0.07	0.7	0.8	●	●		●
	16IRB 1.00 ISO	1.00	9.52	16	0.07	0.7	0.8		●		
	16IRM 1.00 ISO	1.00	9.52	16	0.05	0.6	0.7	●	●		●
	16IR/L 1.25 ISO	1.25	9.52	16	0.09	0.8	0.9	●	●		
	16IRB 1.25 ISO	1.25	9.52	16	0.09	0.7	0.8		●		
	16IRM 1.25 ISO	1.25	9.52	16	0.06	0.8	0.9	●	●		
	16IR/L 1.50 ISO	1.50	9.52	16	0.12	0.9	1.0	●	●	●	●
	16IRB 1.50 ISO	1.50	9.52	16	0.12	0.1	1.2		●		
	16IRM 1.50 ISO	1.50	9.52	16	0.08	0.8	1.0	●	●		●
	16IR/L 1.75 ISO	1.75	9.52	16	0.12	0.9	1.2	●	●		
	16IRB 1.75 ISO	1.75	9.52	16	0.12	0.9	1.2		●		
	16IRM 1.75 ISO	1.75	9.52	16	0.10	0.9	1.2	●	●		
	16IR/L 2.00 ISO	2.00	9.52	16	0.16	0.9	1.2	●	●	●	
	16IRB 2.00 ISO	2.00	9.52	16	0.14	1.0	1.2		●		
	16IRM 2.00 ISO	2.00	9.52	16	0.11	1.0	1.3	●	●		
	16IR/L 2.50 ISO	2.50	9.52	16	0.18	1.1	1.5	●	●	●	
	16IRB 2.50 ISO	2.50	9.52	16	0.18	1.2	1.5		●		
16IRM 2.50 ISO	2.50	9.52	16	0.14	1.1	1.5	●	●			
16IR/L 3.00 ISO	3.00	9.52	16	0.21	1.1	1.5	●	●	●		
16IRB 3.00 ISO	3.00	9.52	16	0.21	1.1	1.5		●			
16IRM 3.00 ISO	3.00	9.52	16	0.22	1.1	1.5	●	●			
22IL 3.00 ISO	3.00	12.70	22	0.17	1.1	1.5			●		
22IR/L 3.50 ISO	3.50	12.70	22	0.23	1.6	2.3	●	●			
22IR/L 4.00 ISO	4.00	12.70	22	0.27	1.6	2.3	●	●		●	
22IR/L 4.50 ISO	4.50	12.70	22	0.31	1.6	2.3	●	●			
22IR/L 5.00 ISO	5.00	12.70	22	0.32	1.7	2.5	●	●			
27IR/L 5.50 ISO	5.50	15.88	27	0.36	1.8	2.5	●	●			
27IR/L 6.00 ISO	6.00	15.88	27	0.40	1.8	2.5	●	●			
 U	08UIRL 2.00 ISO	2.00	4.76	8	0.14	0.8	4.3				
	22UIRL 5.50 ISO	5.50	12.70	22	0.36	2.3	11.0	●			
	22UIRL 6.00 ISO	6.00	12.70	22	0.40	2.1	11.0	●			
	27UIRL 8.00 ISO	8.00	15.88	27	0.50	2.5	13.8		●		

▶ IRB / IRM with pressed chip breaker

●: Standard items

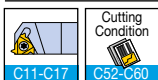

Internal American UN



Full profile, UN, UNC, UNF, UNEF

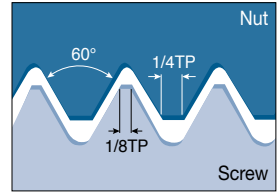
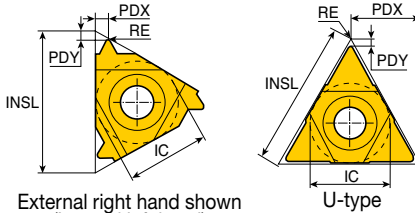

• Application: General industry

Insert	Designation	TPI	Dimension (mm)					Coated			Uncoated	
			IC	INSL	RE	PDY	PDX	TT7010	TT9030	TT8010	P30	
Internal	06IR 32 UN	32	3.97	6	0.04	0.8	0.5				•	
	06IR/L 24 UN	24	3.97	6	0.05	0.7	0.6				•	
	06IR/L 20 UN	20	3.97	6	0.06	0.6	0.6				•	
Regular	06IR 18 UN	18	3.97	6	0.07	0.6	0.7				•	
	08IR 32 UN	32	4.76	8	0.04	0.6	0.5				•	
	08IR 28 UN	28	4.76	8	0.04	0.6	0.6				•	
B/M	08IR 24 UN	24	4.76	8	0.05	0.6	0.6				•	
	08IR/L 20 UN	20	4.76	8	0.06	0.6	0.7				•	
	08IR 18 UN	18	4.76	8	0.07	0.6	0.7				•	
	08IR 16 UN	16	4.76	8	0.09	0.6	0.7				•	
	08IR 14 UN	14	4.76	8	0.10	0.6	0.8			•	•	
	11IR 32 UN	32	6.35	11	0.04	0.6	0.6				•	
	11IR 28 UN	28	6.35	11	0.04	0.6	0.7				•	
	11IR 24 UN	24	6.35	11	0.05	0.7	0.8				•	
	11IR 20 UN	20	6.35	11	0.06	0.8	0.9				•	
	11IR/L 18 UN	18	6.35	11	0.07	0.8	1.0				•	
	11IR/L 16 UN	16	6.35	11	0.09	0.9	1.1				•	
	11IR/L 14 UN	14	6.35	11	0.10	0.9	1.1				•	
	11IR 12 UN	12	6.35	11	0.12	0.9	1.1	•				
	11IR 11 UN	11	6.35	11	0.14	0.8	1.1	•	•			
	16IR 32 UN	32	9.52	16	0.04	0.6	0.6		•	•		
16IR/L 28 UN	28	9.52	16	0.04	0.6	0.7				•		
16IR 24 UN	24	9.52	16	0.05	0.7	0.8				•		
16IRB 24 UN	24	9.52	16	0.05	0.7	0.8				•		
16IR/L 20 UN	20	9.52	16	0.06	0.8	0.9				•		
16IRB 20 UN	20	9.52	16	0.06	0.8	0.9				•		
16IRM 20 UN	20	9.52	16	0.06	0.8	0.9				•		
16IR/L 18 UN	18	9.52	16	0.07	0.8	1.0				•		
16IRB 18 UN	18	9.52	16	0.07	0.8	1.0				•		
16IRM 18 UN	18	9.52	16	0.08	0.8	1.0	•	•				

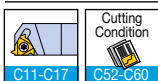

▶ IRB / IRM with pressed chip breaker
 ▶ Tolerance: Class 2B, ANSI B1, 3M-1986

• Standard items

Internal American UN

Full profile, UN, UNC, UNF, UNEF

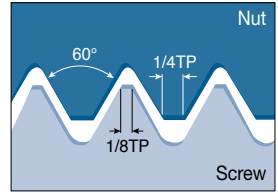
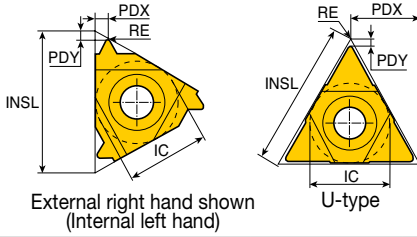

• Application: General industry

Insert	Designation	TPI	Dimension (mm)						Coated			Uncoated
			IC	INSL	RE	PDY	PDX	TT7010	TT9030	TT8010	P30	
Internal Regular B/M	16IR/L 16 UN	16	9.52	16	0.09	0.9	1.1		•			
	16IRB 16 UN	16	9.52	16	0.09	0.9	1.1		•			
	16IRM 16 UN	16	9.52	16	0.09	0.9	1.1	•	•			
	16IR/L 14 UN	14	9.52	16	0.10	0.9	1.2		•			
	16IRB 14 UN	14	9.52	16	0.10	0.9	1.2		•			
	16IRM 14 UN	14	9.52	16	0.11	0.9	1.2	•	•			
	16IR/L 12 UN	12	9.52	16	0.12	1.1	1.4	•	•	•		
	16IRB 12 UN	12	9.52	16	0.12	1.1	1.4		•			
	16IRM 12 UN	12	9.52	16	0.12	1.1	1.4		•			
	16IR 11.5 UN	11.5	9.52	16	0.13	1.1	1.5		•			
	16IR 11 UN	11	9.52	16	0.14	1.1	1.5		•			
	16IR 10 UN	10	9.52	16	0.15	1.1	1.5	•	•			
	16IRB 10 UN	10	9.52	16	0.15	1.1	1.5		•			
	16IR 9 UN	9	9.52	16	0.17	1.2	1.7		•			
	16IR 8 UN	8	9.52	16	0.19	1.1	1.5		•			
	16IRB 8 UN	8	9.52	16	0.19	1.1	1.5		•			
	16IRM 8 UN	8	9.52	16	0.20	1.1	1.5	•	•			
	22IR 7 UN	7	12.70	22	0.22	1.6	2.3		•			
	22IR 6 UN	6	12.70	22	0.26	1.6	2.3		•			
	22IR 5 UN	5	12.70	22	0.32	1.6	2.3		•			
27IR 4 UN	4	15.88	27	0.41	1.8	2.7		•				
Internal U	08UIRL 13 UN	13	4.76	8	0.10	1.0	4.0		•			

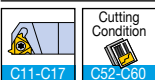

- ▶ IRB / IRM with pressed chip breaker
- ▶ Tolerance: Class 2B, ANSI B1, 3M-1986

• Standard items

Internal Whitworth

Full profile, BSW, BSF, BSP (B.S. 84-1956 DIN 259)

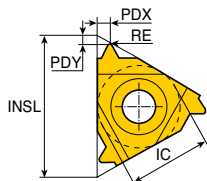

External right hand shown
(Internal left hand)

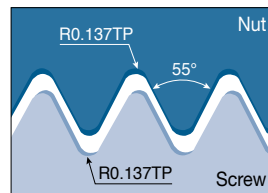
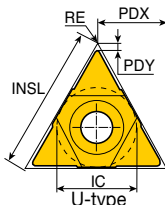

- Application: General industry, fittings and pipe couplings

Insert	Designation	TPI	Dimension (mm)					Coated			Uncoated
			IC	INSL	RE	PDY	PDX	TT7010	TT9030	TT8010	P30
Internal	16IR 32 W	32	9.52	16	0.09	0.6	0.6				•
	16IR 28 W	28	9.52	16	0.09	0.6	0.7	•			
Regular	16IR 26 W	26	9.52	16	0.10	0.7	0.7		•		
	16IR 24 W	24	9.52	16	0.11	0.7	0.8		•		
B/M	16IR/L 20 W	20	9.52	16	0.14	0.8	0.9		•		
	16IRM 20 W	20	9.52	16	0.14	0.8	0.9		•		
	16IR/L 19 W	19	9.52	16	0.15	0.8	1.0	•	•		
	16IRB 19 W	19	9.52	16	0.15	0.8	1.0		•		
	16IRM 19 W	19	9.52	16	0.15	0.8	1.0	•			
	16IR 18 W	18	9.52	16	0.16	0.8	1.0		•		
	16IR 16 W	16	9.52	16	0.18	0.9	1.1		•		
	16IRB 16 W	16	9.52	16	0.18	0.9	1.1		•		
	16IRM 16 W	16	9.52	16	0.18	0.9	1.1		•		
	16IR/L 14 W	14	9.52	16	0.21	1.0	1.2	•	•	•	
	16IRB 14 W	14	9.52	16	0.21	1.0	1.2		•		
	16IRM 14 W	14	9.52	16	0.21	1.0	1.2	•	•		
	16IR/L 12 W	12	9.52	16	0.25	1.1	1.4		•		
	16IR/L 11 W	11	9.52	16	0.27	1.1	1.5	•	•	•	
	16IRB 11 W	11	9.52	16	0.27	1.1	1.5		•		
	16IRM 11 W	11	9.52	16	0.27	1.1	1.5	•	•		
	16IR 10 W	10	9.52	16	0.31	1.1	1.5		•		
	16IRB 10 W	10	9.52	16	0.31	1.1	1.5		•		
	16IR/L 9 W	9	9.52	16	0.34	1.2	1.7	•			
	16IR/L 8 W	8	9.52	16	0.39	1.2	1.5		•		
	22IR 7 W	7	12.70	22	0.45	1.6	2.3		•		
	22IR 6 W	6	12.70	22	0.52	1.6	2.3	•			
	22IR 5 W	5	12.70	22	0.65	1.7	2.4	•			
	27IR 4 W	4	15.88	27	0.82	2.0	2.9		•		

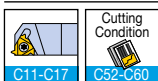

- ▶ IRB / IRM with pressed chip breaker
- ▶ Tolerance: Medium class

- : Standard items

External & Internal NPT





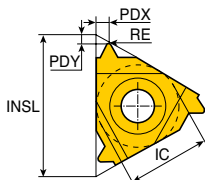

Full profile, national pipe threads (ANSI/ASME B1.20.1-1983)

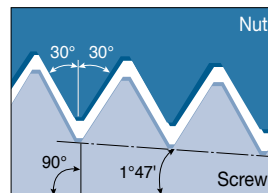

External right hand shown
(Internal left hand)



- Application: Steam, gas and water pipes

Insert	Designation	TPI	Dimension (mm)						Coated			Uncoated
			IC	INSL	RE	PDY	PDX	TT7010	TT9030	TT8010	P30	
External  Regular  B/M	16ER 27 NPT	27	9.52	16	0.04	0.7	0.8		•			
	16ER/L 18 NPT	18	9.52	16	0.06	0.8	1.0	•	•			
	16ERB 18 NPT	18	9.52	16	0.06	0.8	1.0		•			
	16ERM 18 NPT	18	9.52	16	0.05	0.8	1.0		•			
	16ER/L 14 NPT	14	9.52	16	0.07	0.9	1.2		•	•		
	16ERB 14 NPT	14	9.52	16	0.07	0.9	1.2		•			
	16ERM 14 NPT	14	9.52	16	0.05	0.9	1.2	•	•		•	
	16ER/L 11.5 NPT	11.5	9.52	16	0.09	1.1	1.5	•	•		•	
	16ERB 11.5 NPT	11.5	9.52	16	0.09	1.1	1.5		•			
	16ERM 11.5 NPT	11.5	9.52	16	0.09	1.1	1.5		•			
	16ER 8 NPT	8	9.52	16	0.12	1.3	1.8	•	•			
	16ERB 8 NPT	8	9.52	16	0.12	1.3	1.8		•			
16ERM 8 NPT	8	9.52	16	0.15	1.3	1.8	•	•				
Internal  Regular  B/M	06IR 27 NPT	27	3.97	6	0.04	0.6	0.6				•	
	08IR 27 NPT	27	4.76	8	0.04	0.6	0.6				•	
	08IR/L 18 NPT	18	4.76	8	0.06	0.6	0.6				•	•
	11IR/L 18 NPT	18	6.35	11	0.06	0.8	1.0	•	•			
	11IR/L 14 NPT	14	6.35	11	0.07	0.8	1.0		•			
	16IR 18 NPT	18	9.52	16	0.06	0.8	1.0		•			
	16IR/L 14 NPT	14	9.52	16	0.07	0.9	1.2	•	•	•		
	16IRB 14 NPT	14	9.52	16	0.07	0.9	1.2		•			
	16IRM 14 NPT	14	9.52	16	0.05	0.9	1.2		•			
	16IR 11.5 NPT	11.5	9.52	16	0.09	1.1	1.5		•			
	16IRB 11.5 NPT	11.5	9.52	16	0.09	1.1	1.5		•			
	16IRM 11.5 NPT	11.5	9.52	16	0.09	1.1	1.5	•	•		•	
	16IR/L 8 NPT	8	9.52	16	0.12	1.3	1.8		•			
	16IRB 8 NPT	8	9.52	16	0.12	1.3	1.8		•			
	16IRM 8 NPT	8	9.52	16	0.12	1.3	1.8		•			

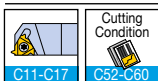

▶ ERB / ERM / IRB / IRM with pressed chip breaker

- Standard items

External & Internal Trapez

DIN 103

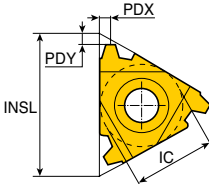

External right hand shown
(Internal left hand)

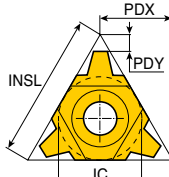

U-type

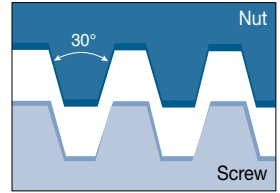

• Application: Feed screws

Insert	Designation	TP (mm)	Dimension (mm)				Coated			Uncoated	
			IC	INSL	PDY	PDX	TT7010	TT9030	TT8010	P30	
 External Regular	16ER 1.5 TR	1.5	9.52	16	1.0	1.1	•	•			
	16ER/L 2 TR	2.0	9.52	16	1.0	1.3	•	•			
	16ER/L 3 TR	3.0	9.52	16	1.3	1.5	•	•			
	22ER/L 4 TR	4.0	12.70	22	1.8	1.9	•	•			
	22ER/L 5 TR	5.0	12.70	22	2.0	2.4	•	•			
	22ER/L 6 TR	6.0	12.70	22	2.0	2.4		•			
	27ER/L 6 TR	6.0	15.88	27	2.3	2.7	•	•			
	27ER/L 7 TR	7.0	15.88	27	2.2	2.6	•	•			
 Internal Regular	08IR 1.5 TR	1.5	4.76	8	0.6	0.6			•		
	16IR 1.5 TR	1.5	9.52	16	1.0	1.1	•				
	16IR/L 2 TR	2.0	9.52	16	1.0	1.3	•	•			
	16IR/L 3 TR	3.0	9.52	16	1.3	1.5		•	•		
	22IR/L 4 TR	4.0	12.70	22	1.8	1.9	•	•			
	22IR/L 5 TR	5.0	12.70	22	2.0	2.4	•	•			
	22IR/L 6 TR	6.0	12.70	22	2.0	2.4	•	•	•	•	
	27IR/L 6 TR	6.0	15.88	27	2.3	2.7	•	•			
	27IR 7 TR	7.0	15.88	27	2.2	2.6	•				
 Internal / External U	22UERL 6 TR	6.0	12.70	22	2.0	11.0		•			
	22UERL 7 TR	7.0	12.70	22	2.3	11.0	•	•			
	22UERL 8 TR	8.0	12.70	22	2.5	11.0	•				
	27UERL 8 TR	8.0	15.88	27	2.5	13.7	•	•			
	27UERL 9 TR	9.0	15.88	27	3.0	13.7	•	•			
	27UERL 10 TR⁽¹⁾	10.0	15.88	27	3.2	13.7		•			
	08UIRL 2 TR	2.0	4.76	8	0.9	4.0			•		
	22UIRL 6 TR	6.0	12.70	22	2.0	11.0	•	•			
	22UIRL 7 TR	7.0	12.70	22	2.3	11.0	•				
	27UIRL 8 TR	8.0	15.88	27	2.5	13.7	•				
	27UIRL 9 TR	9.0	15.88	27	3.0	13.7	•	•			
	27UIRL 10 TR⁽¹⁾	10.0	15.88	27	3.2	13.7		•			

▶ ⁽¹⁾ One cutting edge only
▶ DIN 103 04 / 1977, 150 2901 / 1977 Class 7H (7E)

• Standard items

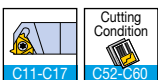

External & Internal American Buttress

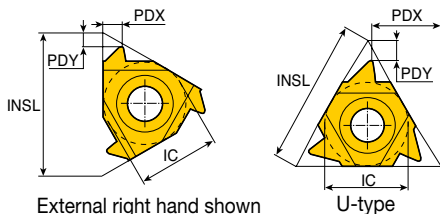



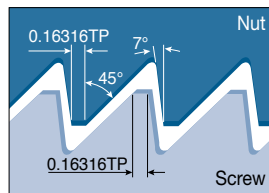

External right hand shown
(Internal left hand)

U-type



• Application: For high forces in one direction

Insert	Designation	TPI	Dimension (mm)				Coated			Uncoated
			IC	INSL	PDY	PDX	TT7010	TT9030	TT8010	P30
 External Regular	16ER 20 ABUT	20	9.52	16	1.0	1.3		•		
	16ER 16 ABUT	16	9.52	16	1.1	1.5		•		
	16ER 12 ABUT	12	9.52	16	1.4	2.0		•		
	16ER/L 10 ABUT	10	9.52	16	1.5	2.3		•		
	22ER 8 ABUT	8	12.70	22	2.1	3.3		•		
	22ER 6 ABUT	6	12.70	22	2.1	3.4		•		
 External U	22UER 4 ABUT	4	12.70	22	2.3	9.5		•		
	27UER 3 ABUT	3	15.88	27	3.1	11.7		•		
 Internal Regular	11IR 20 ABUT	20	6.35	11	1.0	1.3		•		
	11IR 16 ABUT	16	6.35	11	1.0	1.5		•		
	16IR 20 ABUT	20	9.52	16	1.0	1.3		•		
	16IR/L 16 ABUT	16	9.52	16	1.0	1.5		•		
	16IR/L 12 ABUT	12	9.52	16	1.4	2.0	•	•		
	16IR 10 ABUT	10	9.52	16	1.5	2.3		•		
	22IR 8 ABUT	8	12.70	22	2.1	3.3		•		
	22IR/L 6 ABUT	6	12.70	22	2.1	3.4		•		
 Internal U	22UIR 4 ABUT	4	12.70	22	2.3	9.5	•			

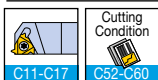

▶ ANSI B1.9-1973 class 2

• Standard items

API - Oil Threads



Round profile, multi-tooth

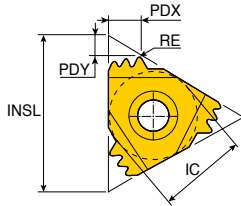

External right hand shown
(Internal left hand)

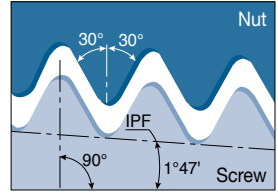

• Application: Oil & gas industry

Insert	Designation	TPI	Dimension (mm)						CICT ⁽¹⁾	Coated		Uncoated	
			IC	INSL	RE	IPF	PDY	PDX		TT7010	TT9030	TT8010	P30
Internal / External 	22ER/IR 10 API RD 2M	10	12.70	22	0.36	0.75	2.4	3.7	2		●		
	27ER/IR 8 API RD 2M	8	15.88	27	0.43	0.75	3.0	4.5	2		●		

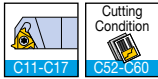

- ▶ API Spec 5B8-1996
- ▶ ⁽¹⁾ Number of teeth per corner

●: Standard items

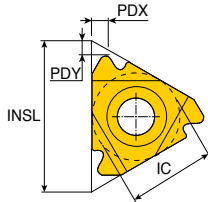

API - Oil Thread Profile

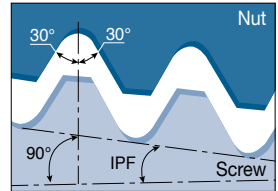

External right hand shown
(Internal left hand)



• Application: Oil & gas industry

Insert	Designation	TPI	Dimension (mm)						Connection No. or size	Coated		Uncoated	
			IC	INSL	IPF	PDY	PDX	TT7010		TT9030	TT8010	P30	
External 	22ER 5 API 403⁽¹⁾	5	12.70	22	3	1.8	2.5	2.375"-4.5"REG		●			
	27ER 4 API 382⁽²⁾	4	15.88	27	2	2.1	2.8	NC23-NC50	●	●			
	27ER 4 API 383⁽²⁾	4	15.88	27	3	2.1	2.8	NC56-NC77		●			
	27ER/L 4 API 502⁽³⁾	4	15.88	27	2	2.0	3.0	6-5/8"REG	●	●			
Regular	27ER 4 API 503⁽³⁾	4	15.88	27	3	2.0	3.0	5-1/2, 7-5/8, 8-5/8"REG		●			
Internal 	22IR 5 API 403⁽¹⁾	5	12.70	22	3	1.8	2.5	2.375"-4.5"REG	●	●			
	27IR 4 API 382⁽²⁾	4	15.88	27	2	2.1	2.8	NC23-NC50	●	●			
	27IR/L 4 API 502⁽³⁾	4	15.88	27	2	2.0	3.0	6-5/8"REG	●				
	Regular												

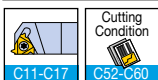

- ▶ ⁽¹⁾ V-0.040 ⁽²⁾ V-0.038R ⁽³⁾ V-0.050
- ▶ 0.050, API spec 74-1994

●: Standard items

Recommended Cutting Conditions



Machining data for thread turning insert

ISO	Material	Condition	Tensile strength (N/mm ²)	Hardness HB	Material No.	
P	Non-alloy steel, cast steel, free cutting steel	<0.25%C	Annealed	420	125	1
		>=0.25%C	Annealed	650	190	2
		<0.55%C	Quenched and tempered	850	250	3
		>=0.55%C	Annealed	750	220	4
			Quenched and tempered	1000	300	5
	Low alloy steel and cast steel (Less than 5% of alloying elements)	Quenched and tempered	600	200	6	
			930	275	7	
			1000	300	8	
			1200	350	9	
	High alloy steel, cast steel and tool steel	Annealed	680	200	10	
Quenched and tempered		1100	325	11		
M	Stainless steel and cast steel	Ferritic / martensitic	680	200	12	
		Martensitic	820	240	13	
		Austenitic	600	180	14	
K	Gray cast iron (GG)	Ferritic		160	15	
		Pearlitic		250	16	
	Cast iron nodular (GGG)	Ferritic		180	17	
		Pearlitic		260	18	
Malleable cast iron	Ferritic		130	19		
	Pearlitic		230	20		
N	Aluminum - Wrought alloy	Not cureable		60	21	
		Cured		100	22	
	Aluminum-cast, alloyed	<=12% Si	Not cureable		75	23
			Cured		90	24
		>12% Si	High temp.		130	25
	Copper alloys	>1% Pb	Free cutting		110	26
			Brass		90	27
			Electrolitic copper		100	28
	Non-metallic	Duroplastics, fiber plastics		70 Shore D	29	
		Hard rubber		55 Shore D	30	
S	High temp. alloys	Fe based	Annealed	200	31	
			Cured	280	32	
		Ni or Co based	Annealed	250	33	
			Cured	350	34	
			Cast	320	35	
	Titanium, Ti alloys	Pure	Rm 400	190	36	
Alpha+beta alloys cured		Rm 1050	310	37		
H	Hardened steel	Hardened		55HRC	38	
		Hardened		60HRC	39	
	Chilled cast iron	Cast		400	40	
	Cast iron nodular	Hardened		55HRC	41	

► For more information of material groups, see the materials & grades "material conversion table"

■ Steel
 ■ Stainless steel
 ■ Cast iron
 ■ Nonferrous
 ■ High temp. alloys
 ■ Hardened steel

Recommended Cutting Conditions



Machining data for thread turning insert

Cutting speed (m/min)					
Coated			Uncoated		
TT7010	TT9030	TT8010	P30		
120-200	140-220	85-125	80-120		
120-200	140-220	85-125	80-120		
110-190	130-210	80-120	70-110		
110-190	130-210	80-120	70-110		
90-170	110-190	70-100	65-95		
70-120	70-120	50-70	70-110		
90-170	110-190	70-100	65-95		
80-120	100-140	60-100	70-110		
70-120	90-140	40-80	40-80		
70-100	70-100	40-70	40-70		
40-80	40-80	40-70	40-70		
85-125	90-130	40-70	40-70		
120-180	130-190	80-120	80-120		
50-100	60-110	40-60	40-60		
	100-140	80-120			
	110-150	80-120			
	110-150	80-120			
	80-120	80-120			
	110-150	60-100			
	80-120	55-95			
	1300-1500	700-900			
	400-600	330-430			
	500-800	350-450			
	370-470	300-360			
	200-280	150-210			
	260-340	160-240			
	350-450	250-310			
	100-140	80-120			
	250-350	160-200			
	250-350	150-210			
	50-70	20-50			
	30-50	20-50			
	30-50	20-40			
	20-40	15-30			
	20-40	15-30			
	120-140	90-110			
	40-60	20-50			
	30-60	20-35			
	20-40	20-30			
	20-40	20-30			
	20-30	15-25			

▶ Thread helix angle and anvil selection

■ Helix angle λ evaluation

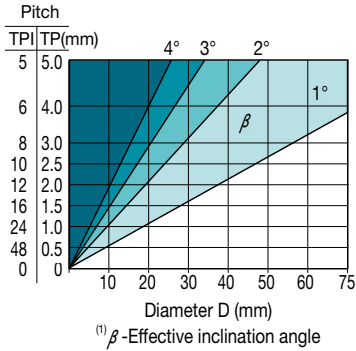

$$\operatorname{tg} \lambda = \frac{1 \times \text{TP}}{3.14 \cdot D}$$

$$\lambda^\circ = \frac{20 \times \text{TP}}{D}$$

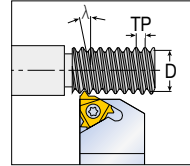

TP - Thread pitch (mm)
 D - Effective diameter of thread (mm)
 λ - Angle of inclination

▶ Anvil selection according to thread helix angle λ

		Standard							
Thread helix angle λ		> 4°	3° - 4°	2° - 3°	1° - 2°	0° - 1°	Negative anvils		
Inclination angle β		4.5°	3.5°	2.5°	1.5°	0.5°	-0.5°	-1.5°	
INSL(C)	Toolholder	Anvil designation							
16	EX RH OR IN LH	AE 16 +4.5	AE 16 +3.5	AE 16 +2.5	AE 16	AE 16 +0.5	AE 16 -0.5	AE 16 -1.5	
(3/8)	EX LH OR IN RH	AI 16 +4.5	AI 16 +3.5	AI 16 +2.5	AI 16	AI 16 +0.5	AI 16 -0.5	AI 16 -1.5	
22	EX RH OR IN LH	AE 22 +4.5	AE 22 +3.5	AE 22 +2.5	AE 22	AE 22 +0.5	AE 22 -0.5	AE 22 -1.5	
(1/2)	EX LH OR IN RH	AI 22 +4.5	AI 22 +3.5	AI 22 +2.5	AI 22	AI 22 +0.5	AI 22 -0.5	AI 22 -1.5	
27	EX RH OR IN LH	AE 27 +4.5	AE 27 +3.5	AE 27 +2.5	AE 27	AE 27 +0.5	AE 27 -0.5	AE 27 -1.5	
(5/8)	EX LH OR IN RH	AI 27 +4.5	AI 27 +3.5	AI 27 +2.5	AI 27	AI 27 +0.5	AI 27 -0.5	AI 27 -1.5	
22U	EX RH OR IN LH	AE 22U +4.5	AE 22U +3.5	AE 22U +2.5	AE 22U	AE 22U +0.5	AE 22U -0.5	AE 22U -1.5	
(1/2U)	EX LH OR IN RH	AI 22U +4.5	AI 22U +3.5	AI 22U +2.5	AI 22U	AI 22U +0.5	AI 22U -0.5	AI 22U -1.5	
27U	EX RH OR IN LH	AE 27U +4.5	AE 27U +3.5	AE 27U +2.5	AE 27U	AE 27U +0.5	AE 27U -0.5	AE 27U -1.5	
(5/8U)	EX LH OR IN RH	AI 27U +4.5	AI 27U +3.5	AI 27U +2.5	AI 27U	AI 27U +0.5	AI 27U -0.5	AI 27U -1.5	

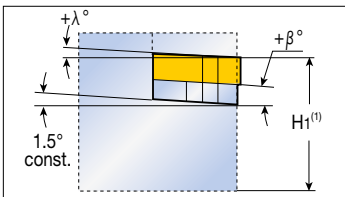

- Anvils for positive inclination angle β applicable when turning
- RH thread with RH holder or LH thread with LH holder

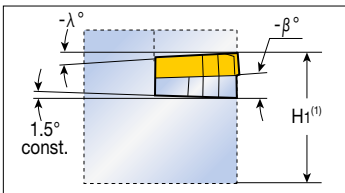

- Anvils for negative inclination β used when turning
- RH thread with LH holder or LH thread with RH holder

▶ ⁽¹⁾ H1 remains constant for every anvil combination.

▶ Anvil selection according to thread helix angle λ

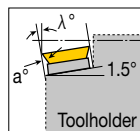
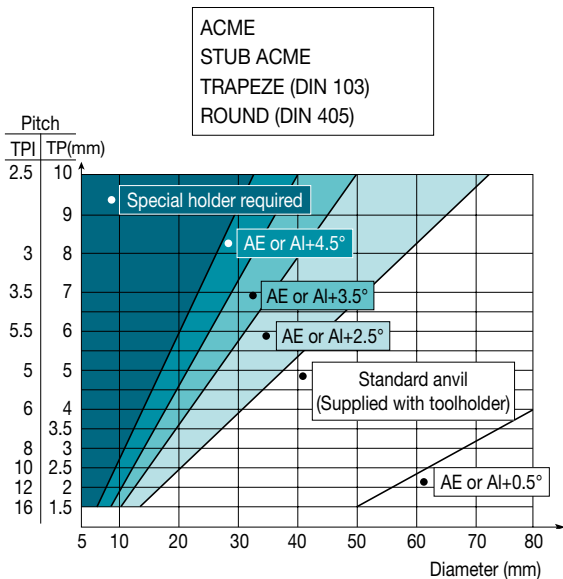

AE anvils : EX-RH and IN-LH toolholders

AI anvils : IN-RH and EX-LH toolholders

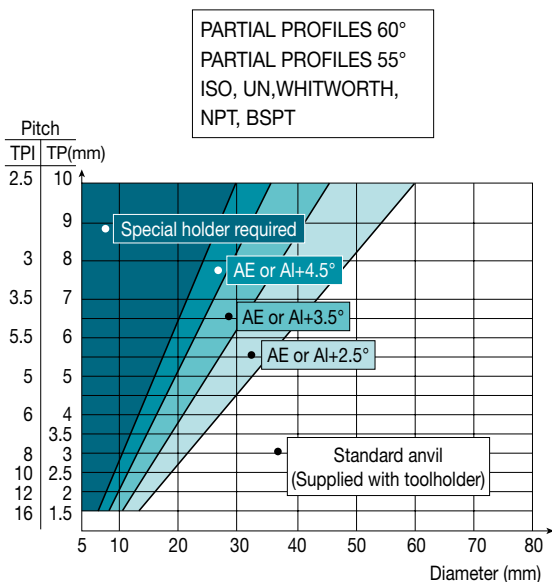

AE anvils : EX-RH and IN-LH toolholders

AI anvils : IN-RH and EX-LH toolholders

► **Maximum depth of first cut for CNC control / external threading
- M-type inserts**

Full profile	Pitch		Insert designation	No. of passes		Max. depth for first pass (D ₁) mm	
	TP (mm)	TPI		Min.	Max.	Low carbon steel	
						Eq. ⁽²⁾	Dim. ⁽³⁾
ISO metric	1.00		16 ERM 1.00 ISO	5	9	0.34	0.51
	1.25		16 ERM 1.25 ISO	6	11	0.42	0.63
	1.50		16 ERM 1.50 ISO	6	12	0.46	0.69
	1.75		16 ERM 1.75 ISO	8	13	0.48	0.72
	2.00		16 ERM 2.00 ISO	8	14	0.50	0.75
	2.50		16 ERM 2.50 ISO	10	15	0.53	0.80
	3.00		16 ERM 3.00 ISO	12	17	0.56	0.84
American UN		24	16 ERM 24 UN	5	9	0.34	0.51
		20	16 ERM 20 UN	6	10	0.42	0.63
		18	16 ERM 18 UN	6	11	0.46	0.69
		16	16 ERM 16 UN	7	12	0.47	0.71
		14	16 ERM 14 UN	6	13	0.46	0.69
		12	16 ERM 12 UN	8	14	0.50	0.75
		8	16 ERM 8 UN	12	17	0.56	0.84
British BSW		19	16 ERM 19 W	6	11	0.35	0.52
		16	16 ERM 16 W	7	12	0.47	0.71
		14	16 ERM 14 W	8	13	0.50	0.75
		11	16 ERM 11 W	9	14	0.44	0.66
NPT		18	16 ERM 18 NPT	10	20	0.24	0.36
		14	16 ERM 14 NPT	13	26	0.24	0.36
		11.5	16 ERM 11.5 NPT	15	24	0.27	0.40
		8	16 ERM 8 NPT	17	30	0.31	0.46
Round		6	16 ERM 6 RND	9	20	0.42	0.63
Partial profile 60°		48-16	16 ERM A 60	(1)		0.22	0.33
		14-8	16 ERM G 60		0.50	0.75	
		48-8	16 ERM AG 60		0.24	0.36	
		7-5	16 ERM N 60		0.41	0.62	
Partial profile 55°		14-8	16 ERM G 55		0.50	0.75	
		48-8	16 ERM AG 55	0.22	0.33		

► ⁽¹⁾ As per the number of passes for the relevant pitch

⁽²⁾ Equal depth of cut method

⁽³⁾ Diminished depth of cut for each pass method

Max. depth for first pass (D1) mm							
High carbon steel		Alloy steel		Stainless steel		Nonferrous aluminum	
Eq. ⁽²⁾	Dim. ⁽³⁾	Eq. ⁽²⁾	Dim. ⁽³⁾	Eq. ⁽²⁾	Dim. ⁽³⁾	Eq. ⁽²⁾	Dim. ⁽³⁾
0.31	0.46	0.27	0.41	0.22	0.33	0.48	0.71
0.38	0.57	0.34	0.50	0.27	0.41	0.59	0.88
0.41	0.62	0.37	0.55	0.30	0.45	0.64	0.97
0.43	0.65	0.38	0.58	0.31	0.47	0.67	1.01
0.45	0.68	0.40	0.60	0.33	0.49	0.70	1.05
0.48	0.72	0.42	0.64	0.34	0.52	0.74	1.12
0.50	0.76	0.45	0.67	0.36	0.55	0.78	1.18
0.31	0.46	0.27	0.41	0.22	0.33	0.48	0.71
0.38	0.57	0.34	0.50	0.27	0.41	0.59	0.88
0.41	0.62	0.37	0.55	0.30	0.45	0.64	0.97
0.42	0.64	0.38	0.57	0.31	0.46	0.66	0.99
0.41	0.62	0.37	0.55	0.28	0.41	0.64	0.97
0.45	0.68	0.40	0.60	0.33	0.49	0.70	1.05
0.50	0.76	0.45	0.67	0.36	0.55	0.78	1.18
0.32	0.47	0.28	0.42	0.21	0.31	0.49	0.73
0.42	0.64	0.38	0.57	0.31	0.46	0.66	0.99
0.45	0.68	0.40	0.60	0.33	0.49	0.70	1.05
0.40	0.59	0.35	0.53	0.29	0.43	0.62	0.92
0.22	0.32	0.19	0.29	0.16	0.23	0.34	0.50
0.22	0.32	0.19	0.29	0.14	0.22	0.34	0.50
0.24	0.36	0.22	0.32	0.18	0.26	0.38	0.56
0.28	0.41	0.25	0.37	0.20	0.30	0.43	0.64
0.38	0.57	0.34	0.50	0.27	0.41	0.59	0.88
0.20	0.30	0.18	0.26	0.14	0.21	0.31	0.46
0.45	0.68	0.40	0.60	0.33	0.49	0.70	1.05
0.22	0.32	0.19	0.29	0.16	0.23	0.34	0.50
0.37	0.56	0.33	0.50	0.27	0.40	0.57	0.87
0.45	0.68	0.40	0.60	0.33	0.49	0.70	1.05
0.20	0.30	0.18	0.26	0.14	0.21	0.31	0.46

▶ Maximum depth of first cut for CNC control / internal threading - M-type inserts

Full profile	Pitch		Insert designation	No. of passes		Max. depth for first pass (D1) mm	
	TP (mm)	TPI		Min.	Max.	Low carbon steel	
						Eq. ⁽²⁾	Dim. ⁽³⁾
ISO metric	1.50		11 IRM 1.50 ISO	10	20	0.20	0.30
	1.00		16 IRM 1.00 ISO	9	16	0.14	0.20
	1.25		16 IRM 1.25 ISO	9	16	0.19	0.28
	1.50		16 IRM 1.50 ISO	10	20	0.20	0.30
	1.75		16 IRM 1.75 ISO	11	18	0.21	0.32
	2.00		16 IRM 2.00 ISO	12	21	0.22	0.33
	2.50		16 IRM 2.50 ISO	14	21	0.23	0.34
	3.00		16 IRM 3.00 ISO	16	22	0.24	0.35
American UN		20	16 IRM 20 UN	7	13	0.20	0.30
		18	16 IRM 18 UN	8	15	0.20	0.30
		16	16 IRM 16 UN	11	19	0.20	0.30
		14	16 IRM 14 UN	11	20	0.21	0.31
		12	16 IRM 12 UN	12	21	0.23	0.34
		8	16 IRM 8 UN	14	20	0.24	0.36
British BSW		19	16 IRM 19 W	7	12	0.28	0.42
		16	16 IRM 16 W	9	14	0.26	0.39
		14	16 IRM 14 W	10	16	0.27	0.41
		11	16 IRM 11 W	12	19	0.31	0.46
NPT		14	16 IRM 14 NPT	21	35	0.13	0.20
		11.5	16 IRM 11.5 NPT	21	33	0.17	0.25
		8	16 IRM 8 NPT	20	34	0.23	0.34
Round		6	16 IRM 6 RND	12	24	0.30	0.46
Partial profile 60°		48-16	06 IRM A 60	(1)		0.22	0.33
		48-16	08 IRM A 60			0.13	0.20
		48-16	11 IRM A 60			0.13	0.20
		48-16	16 IRM A 60			0.13	0.20
		14-8	16 IRM G 60			0.22	0.33
		48-8	16 IRM AG 60			0.14	0.21
		7-5	22 IRM N 60			0.23	0.34
Partial profile 55°		14-8	16 IRM G 55			0.34	0.50
		48-8	16 IRM AG 55			0.14	0.20

▶ ⁽¹⁾ As per the number of passes for the relevant pitch

⁽²⁾ Equal depth of cut method

⁽³⁾ Diminished depth of cut for each pass method

▶ Number of cutting passes for regular type inserts

Pitch	TP (mm)	0.5	1.0	1.5	2.0	2.5	3.0	4.0	6.0
	TPI	48	24	16	12	10	8	6	4
Number of passes		4-6	5-9	5-12	6-14	7-15	8-17	10-20	11-22

▶ For mini-tools (06IR or 08IR) add 1-3 passes. Increase for hard materials

Max. depth for first pass (D1) mm							
High carbon steel		Alloy steel		Stainless steel		Nonferrous aluminum	
Eq. ⁽²⁾	Dim. ⁽³⁾	Eq. ⁽²⁾	Dim. ⁽³⁾	Eq. ⁽²⁾	Dim. ⁽³⁾	Eq. ⁽²⁾	Dim. ⁽³⁾
0.18	0.27	0.16	0.24	0.12	0.18	0.28	0.42
0.13	0.18	0.11	0.16	0.09	0.13	0.20	0.28
0.17	0.25	0.15	0.22	0.12	0.18	0.27	0.39
0.18	0.27	0.16	0.24	0.12	0.18	0.28	0.42
0.19	0.29	0.17	0.26	0.14	0.21	0.29	0.45
0.20	0.30	0.18	0.26	0.14	0.21	0.31	0.46
0.21	0.31	0.18	0.27	0.15	0.22	0.32	0.48
0.22	0.32	0.19	0.29	0.16	0.23	0.34	0.50
0.18	0.27	0.16	0.24	0.12	0.18	0.28	0.42
0.18	0.27	0.16	0.24	0.12	0.18	0.28	0.42
0.18	0.27	0.16	0.24	0.13	0.20	0.28	0.42
0.19	0.28	0.17	0.25	0.13	0.19	0.29	0.43
0.21	0.31	0.18	0.27	0.15	0.22	0.32	0.48
0.22	0.32	0.19	0.29	0.16	0.23	0.34	0.50
0.25	0.38	0.22	0.34	0.17	0.25	0.39	0.59
0.23	0.35	0.21	0.31	0.17	0.25	0.36	0.55
0.24	0.37	0.22	0.33	0.18	0.27	0.38	0.57
0.28	0.41	0.25	0.37	0.20	0.30	0.43	0.64
0.12	0.18	0.10	0.16	0.08	0.12	0.18	0.28
0.15	0.23	0.14	0.20	0.11	0.16	0.24	0.35
0.21	0.31	0.18	0.27	0.14	0.20	0.32	0.48
0.27	0.41	0.24	0.37	0.20	0.30	0.42	0.64
0.20	0.30	0.18	0.26	0.14	0.21	0.31	0.46
0.12	0.18	0.10	0.16	0.08	0.13	0.18	0.28
0.12	0.18	0.10	0.16	0.08	0.13	0.18	0.28
0.20	0.30	0.18	0.26	0.14	0.21	0.31	0.46
0.13	0.19	0.11	0.17	0.09	0.14	0.20	0.29
0.21	0.31	0.18	0.27	0.15	0.22	0.32	0.48
0.31	0.45	0.27	0.40	0.22	0.33	0.48	0.70
0.13	0.18	0.11	0.16	0.09	0.13	0.20	0.28

► Recommended number of passes for multi-tooth insert

Full profile	Insert description	No. of passes	1 st pass	2 nd pass	3 rd pass	4 th pass	External / internal
ISO metric	16 ER 1.0 ISO 3M	2	0.39	0.24	-	-	External
	16 ER 1.5 ISO 2M	3	0.40	0.31	0.21	-	External
	22 ER 1.5 ISO 3M	2	0.54	0.38	-	-	External
	22 ER 2.0 ISO 2M	3	0.56	0.42	0.27	-	External
	22 ER 2.0 ISO 3M	2	0.75	0.50	-	-	External
	27 ER 3.0 ISO 2M	4	0.60	0.52	0.44	0.30	External
	16 IR 1.0 ISO 3M	2	0.32	0.26	-	-	Internal
	16 IR 1.5 ISO 2M	3	0.36	0.29	0.22	-	Internal
	22 IR 1.5 ISO 3M	2	0.49	0.38	-	-	Internal
	22 IR 2.0 ISO 2M	3	0.50	0.40	0.25	-	Internal
	22 IR 2.0 ISO 3M	2	0.72	0.43	-	-	Internal
27 IR 3.0 ISO 2M	4	0.57	0.45	0.38	0.33	Internal	
UN	16 ER 16 UN 2M	3	0.45	0.32	0.20	-	External
	22 ER 16 UN 3M	2	0.60	0.37	-	-	External
	22 ER 12 UN 2M	3	0.60	0.39	0.31	-	External
	22 ER 12 UN 3M	2	0.80	0.50	-	-	External
	27 ER 8 UN 2M	4	0.63	0.55	0.42	0.36	External
	16 IR 16 UN 2M	3	0.40	0.29	0.23	-	Internal
	22 IR 16 UN 3M	2	0.57	0.35	-	-	Internal
	22 IR 12 UN 2M	3	0.55	0.39	0.28	-	Internal
	22 IR 12 UN 3M	2	0.75	0.47	-	-	Internal
	27 IR 8 UN 2M	4	0.65	0.49	0.42	0.27	Internal
NPT	22 ER 11.5 NPT 2M	4	0.55	0.46	0.35	0.32	External
	27 ER 11.5 NPT 3M	3	0.75	0.57	0.36	-	External
	27 ER 8 NPT 2M	4	0.80	0.62	0.54	0.45	External
	22 IR 11.5 NPT 2M	4	0.55	0.46	0.35	0.32	Internal
	27 IR 11.5 NPT 3M	3	0.75	0.57	0.36	-	Internal
	27 IR 8 NPT 2M	4	0.80	0.62	0.54	0.45	Internal
Whitworth	16 ER 14 W 2M	3	0.51	0.39	0.26	-	External
	22 ER 14 W 3M	2	0.72	0.44	-	-	External
	22 ER 11 W 2M	3	0.65	0.46	0.37	-	External
	16 IR 14 W 2M	3	0.51	0.39	0.26	-	Internal
	22 IR 14 W 3M	2	0.72	0.44	-	-	Internal
	22 IR 11 W 2M	3	0.65	0.46	0.37	-	Internal
API round	22 ER 10 API RD 2M	3	0.58	0.53	0.30	-	External
	27 ER 10 API RD 3M	2	0.98	0.43	-	-	External
	27 ER 8 API RD 2M	3	0.82	0.59	0.40	-	External
	22 IR 10 API RD 2M	3	0.58	0.53	0.30	-	Internal
	27 IR 10 API RD 3M	2	0.98	0.43	-	-	Internal
	27 IR 8 API RD 2M	3	0.82	0.59	0.40	-	Internal

HOLEMAKING



HOLEMAKING



contents

Tool Selection Guide	D4
Grades	D16
Indexable Drills	
TOP-DRILL (Ø12-Ø80)	D18
T-DRILL (Ø12.5-Ø80)	D34
Head Changeable Drills	
DRILL-SFEED (Ø12-Ø25.9)	D55
WIN-DRILL (Small dia. Ø4-Ø5.9)	D58
DRILL-RUSH (Ø6-Ø25.9)	D59
WIN-DRILL (Modular type Ø6-Ø20.9)	D71
MODU-R-DRILL (Ø26-Ø50)	D75
SPADE-RUSH (Ø20-Ø41)	D80
Solid Drills	
SOLID-3-DRILL (Ø4-Ø12)	D83
H-DRILL (Ø3-Ø12)	D89
T-CHAMFER (Ø7-Ø20)	D107
Multifunctional Tools	
TOP-CAP (Ø8-Ø32)	D51

Guide to Icons



➤ External Coolant



➤ Internal Coolant



➤ Through Hole



➤ Blind Hole



➤ Tube Page

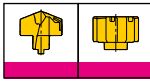

➤ Head Page



➤ Pad Page



➤ Cartridge Page

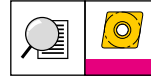

➤ Insert Page

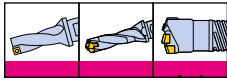

➤ Drill Body & Deep Drill Head Page



➤ Assembly Page



➤ Technical Data Page



➤ Cutting Condition Page



Reaming Tools

XM-REAM (Ø8-Ø12)	D112
TM-REAM (Ø11.5-Ø32)	D115
TB-REAM (Ø8-Ø32)	D118
TS-REAM (Ø3-Ø12)	D122

Deep Drilling Tools

WIN-GUN (Ø10-Ø25)	D125
T-DEEP	D127

Drilling Heads & Inserts

	D180
--	------

Recommended Cutting Conditions

	D226
--	------

Technical Data











	D272
--	------

Tailor-made Order Form

	D282
--	------

Tool Selection Guide

Drilling tools

Series			Indexable drill				
			<i>TOPDRILL</i>		<i>TDRILL</i>		<i>TOPCAP</i>
			TOP 2/3/4/5	TOP-CA	TDR 2/3/4/5	TDR-CA	TCAP
							
Pages			D18-D29	D30-D33	D34-D46	D47-D49	D51-D53
DC(mm)			Ø12.0-Ø50.0	Ø51.0-Ø80.0	Ø12.5-Ø50.0	Ø51.0-Ø80.0	Ø8.0-Ø32.0
Drilling depth(L/D)			2, 3, 4, 5 x Dc	2, 3, 4 x Dc	2, 3, 4, 5 x Dc	2.5, 3.5 x Dc	2.25, 3 x Dc
Hole tolerance			IT 11-13	IT 12-13	IT 12-13	IT 12-13	IT 10-12
Application	General drilling		●	●	●	●	●
	Cross hole drilling		●	●	●	●	
	Irregular surface drilling		○	○	○	○	●
	Interrupted drilling		○	○	○	○	
	Chamfering						
Coolant supply			Internal	Internal	Internal	Internal	Internal

Tool Selection Guide









Drilling tools

Head changeable drill					
<i>DRILLSPEED</i>	<i>WINDRILL</i>	<i>DRILLRUSH</i>			<i>WINDRILL</i>
3ED	TCD...AO	TCD	TCD-M	TCD...AO 3/5/8D	TCD-MRS/TCDM
					
D55-D57	D58	D59-D67	D68	D70	D71-D74
Ø12.0-Ø25.9	Ø4.0-Ø5.9	Ø6.0-Ø25.9	M8-M24 (ISO)	Ø6.0-Ø9.9	Ø6.0-Ø20.9
3, 5, 8 x Dc	3, 5 x Dc	1, 5, 3, 5, 8, 12 x Dc		3, 5, 8 x Dc	2, 3, 4 x Dc
IT 9-10	IT 9-10	IT 9-10	IT 9-10	IT 9-10	IT 9-10
●	●	●	●	●	●
○	●	●		●	●
			●		
Internal	Internal	Internal	Internal	Internal	Internal

● Recommended, ○ Suitable

Tool Selection Guide

Drilling tools

Series		Head changeable drill			Solid carbide drill
		<i>WINGUN</i>	<i>MODURDRILL</i>	<i>SPADERUSH</i>	<i>SOLID3DRILL</i>
		TCDGN	TNDH-TP/ MDB	LCD	3HD
					
Pages		D125-D126	D75-D79	D80-D82	D83-D88
DC(mm)		Ø10.0-Ø25.9	Ø26.0-Ø50.0	Ø20.0-Ø41.0	Ø4.0-Ø12.0
Drilling depth(L/D)		16, 20 x Dc	3, 5 x Dc	3, 5, 8 x Dc	3, 5, 8, 12 x Dc
Hole tolerance		IT 9-10	IT 10-12	IT 9-10	IT 8-10
Application	General drilling		•	•	•
	Cross hole drilling		•	•	•
	Irregular surface drilling				
	Interrupted drilling				
	Chamfering				
Coolant supply		Internal	Internal	Internal	Internal

Tool Selection Guide













Drilling tools

Solid carbide drill				
HDRILL				
NHD-PE/PI	NHD-KI	SHO 10/15/20	SHO-M	CDF
				
D89-D100	D101-D102	D104	D105	D106
Ø3.0-Ø12.0	Ø3.0-Ø12.0	Ø4.0-Ø10.0	M4-M10 (ISO)	Ø3.0-Ø12.7
3, 5 x Dc	3, 5 x Dc	10, 15, 20 x Dc		
IT 8-10	IT 8-10	IT 8-10	IT 8-10	IT 8-10
●	●	●	●	●
●	●	○		
			●	
External / Internal	Internal	Internal	Internal	External

● Recommended, ○ Suitable

Tool Selection Guide





Reaming tools

Series			Indexable reamer		Solid reamer		
			<i>XM-REAM</i>	<i>TM-REAM</i>	<i>TB-REAM</i>	<i>TS-REAM</i>	
			XR-S0	TM	TB	TS	
							
Pages			D112-D113	D115	D118-D119	D122-D123	
DC(mm)			Ø8.000-Ø12.999	Ø11.501-Ø32.000	Ø8.000-Ø32.000	Ø3.000-Ø12.000	
Reaming depth(L/D)			3, 5 x Dc	3, 5, 8 x Dc	5-9 x Dc	7.5-10 x Dc	
Hole tolerance			IT 7 ★	IT 7 ★	IT 6 ★★	IT 7	
Application		Through	Blind				
	General reaming			•	•	•	•
	Cross hole reaming					•	•
	Irregular surface reaming					•	•
	Interrupted reaming			•	•	•	•
Coolant supply			Internal	Internal	Internal	Internal	

★ Up to IT 6 tolerance ★★ Up to IT 5 tolerance

Tool Selection Guide

Deep drilling tools

Series		Indexable deep drill head				
						
		TRGD/TRGD3 /TRGDL	TBTA3	TBTA5	TBTA7	TBTA9
						
Pages		D127-D133	D134-D139	D140-D143	D144-D146	D147-D149
DC(mm)		Ø10.0-Ø36.0	Ø38.00-Ø106.99	Ø107.00-Ø168.99	Ø169.00-Ø232.99	Ø233.00-Ø293.99
Drilling depth(L/D)		10-25 x Dc	100 x Dc	100 x Dc	100 x Dc	100 x Dc
Hole tolerance		IT 10-11	IT 10	IT 10	IT 10	IT 10
Surface finish			3µm	3µm	3µm	3µm
Single tube	Outer four thread		●	●	●	●
	Inner single thread		●	●	●★	●
Double tube	Outer four thread		●	●		

★ In case of inner single thread connection TBTA7 series can cover up to dia. 245.99mm









Series		Indexable deep drill & boring head			Brazed deep drill head	
						
		TBTA-FB	TBTA-TR	TBTA-R	BTA-SE/DE	BTS-SE
						
Pages		D150-D155	D162-D165	D156-D161	D166-D168	D169
DC(mm)		Ø25.00-Ø89.00	Ø16.00-Ø40.00	Ø25.00-Ø110.99	Ø12.60-Ø65.00	Ø8.00-Ø20.00
Drilling depth(L/D)		100 x Dc	100 x Dc	100 x Dc	100 x Dc	100 x Dc
Hole tolerance		IT 10	IT 10	IT 7 - IT 9	IT 9	IT 9
Surface finish		3µm	3µm	1-2µm	2µm	2µm
Single tube	Outer four thread	●	●	●	●	●★
	Inner single thread	●	●	●		
Double tube	Outer four thread	●	●		●	

★ Two start thread: Diameter 12.60 to 15.59mm

● Recommended

Tool Selection Guide

Drill inserts

		TOPDRILL		TDRILL		DRILLSPEED			
		SOMT		SPMG / SPGG		3ED-P+		3ED-F	
Series									
Pages		D180-D181		D182-D183		D184-D186		D187	
Size		04/05/06/07/08 09/11/13/15		05/06/07/09 11/12/14		Ø12.0-Ø25.9		Ø12.0-Ø25.9	
Chip former		DP, DK, DL, DA		DG, DK, DA		P+		F	
Grades		TT9080, TT9300 TT8020, TT6080, K10		TT9030, TT8020 TT7400, TT6030, K10		TT5130		TT5130	
Application	General drilling		•	•	•	•	•	•	
	Cross hole drilling		•	•	•	•	•		
	Irregular surface drilling		○	○	○	○	○		
	Interrupted drilling		○	○					
	Chamfering								

Tool Selection Guide









Drill inserts

WINDRILL		DRILLRUSH			
TCD-P	TCD-P/M/K/N	TCD-P+	TCD-F	AOMT	CRNG
					
D188	D189-D195	D196-D200	D201-D202	D203	D203
Ø4.0-Ø5.9	Ø6.0-Ø25.9	Ø6.0-Ø25.9	Ø6.0-Ø25.9	03,04,06-C30/C45	08-45CD
P	P/M/K/N	P+	F	-	-
TT9080	TT9080 UF10	TT9080	TT9080	TT9080	TT9080
●	●	●	●		
●	●	●	●		
○	○	○	○		
				●	●

● Recommended, ○ Suitable

Tool Selection Guide

Drill inserts

			MODURDRILL		SPADEFUSH	
			TCD-P-CO+	SPGX...DW	LCD-P	LCD-P+
Series						
Pages			D204	D204	D205-D206	D207
Size			Ø15.9-Ø25.9	06/07/09/11/14	Ø20.0-Ø41.0	Ø20.0-Ø34.5
Chip former			P-CO+	DW	P	P+
Grades			TT9080	TT9080	TT9080	TT9080
Application	General drilling		●	●	●	●
	Cross hole drilling		●	●	●	●
	Irregular surface drilling		○	○	○	○
	Interrupted drilling					
	Chamfering					

Tool Selection Guide









Drill inserts

<i>SPADE RUSH</i>	<i>T CHAMFER</i>	<i>TOP CAP</i>	<i>T DEEP</i>	
LCD-F	XCGT-C	XCGT-TA XCMT	NPHT NPMT	NPMX TPMX
				
D208-D209	D210	D211-D212	D213 -D215	D216
Ø20.0-Ø41.0	06/09	04/05/06/07/08 10/13/17	06/07/08/09 /11/13	08/14/17/24/28
F	C30/C45/C60	TA/GV/TC	R(L)-G... /R(L)-HF..	R-B/R-G
TT9080	TT9080	TT9080, TT8020, TT9030, K10	TT9030, TT9130, TT8125, TT6130, TT5030	TT9030, TT9130, TT8125, TT7200, TT6130, TT6020, TT5100, TT5030
●		●	●	●
●			○	○
○				
	●			

● Recommended, ○ Suitable











Tool Selection Guide

Drill inserts

		T_{DEEP}			
		TOGT	ZSGT	LOGT	TPMX XPMT
Series					
Pages		D218	D217	D217	D219
Size		07/08/09/10/11 /12/13/14	06	06	14/16/17/24
Chip former		RS/GF	RS	RS	LG/-45
Grades		TT9030	TT9130	TT9130, TT8125	TT9030, TT9130, TT6020, TT5100
Application	General drilling		•	•	•
	Cross hole drilling				○
	Irregular surface drilling				
	Interrupted drilling				
	Chamfering				

Tool Selection Guide

Reamer heads & blades

			<i>XM-REAM</i>	<i>TM-REAM</i>	<i>TBREAM</i>	
			XR	TM	TB	
Series						
Pages			D114	D116 - D117	D121	
Size			Ø8.000-Ø12.000	Ø11.50-Ø32.000	1/2/3/4	
Chip former			AS/BL	AS/BL	A06/B06/B12	
Grades			TT9030	TT9030	TT5030, TT5050	
Application		Through	Blind			
	General reaming			●	●	●
	Cross hole reaming					
	Irregular surface reaming					
	Interrupted reaming					

● Recommended, ○ Suitable

Grades

Holemaking grades

Grades	ISO	Characteristics & applications
TT6080 PVD carbide	K05 – K25 H05 – H25	<ul style="list-style-type: none"> • General machining for gray and ductile cast iron • Finish and medium machining of hardened steel
TT9300 CVD carbide	P10 – P25	<ul style="list-style-type: none"> • High speed drilling of carbon & alloy steel
TT5130 PVD carbide	P20 – P40 K20 – K40	<ul style="list-style-type: none"> • High speed drilling of carbon & alloy steel
TT9080 PVD carbide	P20 – P40 M20 – M40 S20 – S40	<ul style="list-style-type: none"> • General machining of steel • General machining of stainless steel • General machining of heat-resistant alloy
TT9030 PVD carbide	P20 – P40 M20 – M40 S20 – S40	<ul style="list-style-type: none"> • General machining of steel • General machining of stainless steel • General machining of heat-resistant alloy
TT8020 PVD carbide	P30 – P50 M30 – M50 S30 – S50	<ul style="list-style-type: none"> • Interrupted and rough machining of steel • Interrupted and rough machining of stainless steel • Low speed and interrupted machining of heat-resistant alloy
K10 Uncoated	K05 – K15 N05 – N15 S05 – S15	<ul style="list-style-type: none"> • General machining of cast iron • General machining of aluminum alloys and non-ferrous materials • General machining of heat-resistant alloy
UF1A/UF10 Uncoated	N10 – N25 S10 – S30	<ul style="list-style-type: none"> • General machining of aluminum alloys and non-ferrous materials • General machining of heat-resistant alloy

Selection guide for holemaking grades

For steel

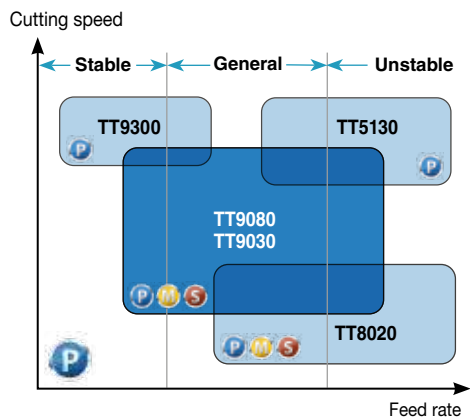

For cast iron

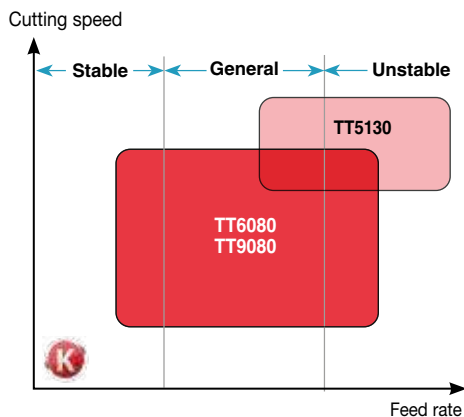

Drilling Tools



TOP 2...-T2



Indexable drill holders



- Drilling depth: 2x diameter

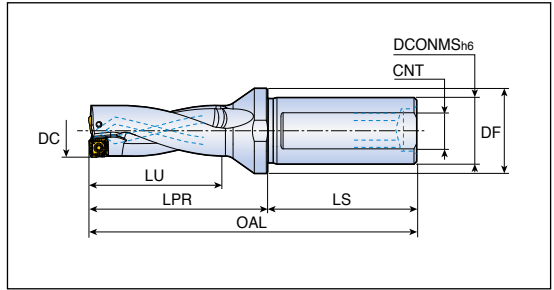

Designation	Dimension (mm)							Insert
	DC	DCONMS	DF	LU	LPR	LS	CNT	
TOP 2120-20T2-04	12.0	20	25	24	44	50	M13X1.0	SOMT 04...DP
2125-20T2-04	12.5	20	25	26	46	50	M13X1.0	D180
2130-20T2-04	13.0	20	25	26	46	50	M13X1.0	
2135-20T2-04	13.5	20	25	28	46	50	M13X1.0	
2140-20T2-05	14.0	20	25	28	46	50	M13X1.0	SOMT 05...DP/DL/DK/DA
2145-20T2-05	14.5	20	25	30	49	50	M13X1.0	D180-D181
2150-20T2-05	15.0	20	25	30	49	50	M13X1.0	
2155-20T2-05	15.5	20	25	32	52	50	M13X1.0	
2160-20T2-05	16.0	20	25	32	52	50	M13X1.0	
2165-25T2-06	16.5	25	32	34	54	56	M16X1.5	SOMT 06...DP/DL/DK/DA
2170-25T2-06	17.0	25	32	34	54	56	M16X1.5	D180-D181
2175-25T2-06	17.5	25	32	36	57	56	M16X1.5	
2180-25T2-06	18.0	25	32	36	57	56	M16X1.5	
2185-25T2-06	18.5	25	32	38	59	56	M16X1.5	
2190-25T2-06	19.0	25	32	38	59	56	M16X1.5	
2195-25T2-07	19.5	25	32	40	63	56	M16X1.5	SOMT 07...DP/DL/DK/DA
2200-25T2-07	20.0	25	32	40	63	56	M16X1.5	D180-D181
2205-25T2-07	20.5	25	32	42	65	56	M16X1.5	
2210-25T2-07	21.0	25	32	42	65	56	M16X1.5	
2215-25T2-07	21.5	25	32	44	67	56	M16X1.5	
2220-25T2-07	22.0	25	32	44	67	56	M16X1.5	
2225-25T2-08	22.5	25	32	46	68	56	M16X1.5	SOMT 08...DP/DL/DK/DA
2230-25T2-08	23.0	25	32	46	68	56	M16X1.5	D180-D181
2230-32T2-08	23.0	32	40	46	68	60	M22X2.0	
2235-25T2-08	23.5	25	32	48	70	56	M16X1.5	
2235-32T2-08	23.5	32	40	48	70	60	M22X2.0	
2240-25T2-08	24.0	25	32	48	70	56	M16X1.5	
2240-32T2-08	24.0	32	40	48	70	60	M22X2.0	
2245-25T2-08	24.5	25	32	50	72	56	M16X1.5	
2245-32T2-08	24.5	32	40	50	72	60	M22X2.0	
2250-25T2-08	25.0	25	32	50	72	56	M16X1.5	
2250-32T2-08	25.0	32	40	50	72	60	M22X2.0	
2255-25T2-08	25.5	25	32	52	73	56	M16X1.5	
2255-32T2-08	25.5	32	40	52	73	60	M22X2.0	
2260-25T2-08	26.0	25	32	52	73	56	M16X1.5	
2260-32T2-08	26.0	32	40	52	73	60	M22X2.0	



► OAL: LPR+LS

D226

Indexable drill holders



- Drilling depth: 2x diameter

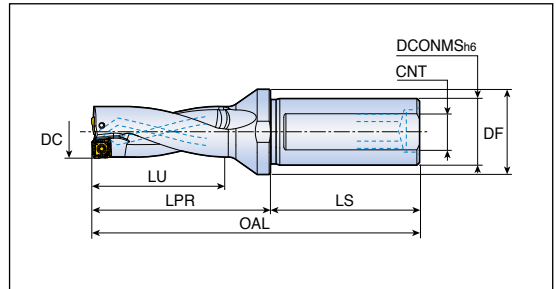

Designation	Dimension (mm)							Insert
	DC	DCONMS	DF	LU	LPR	LS	CNT	
TOP 2265-32T2-09	26.5	32	40	54	77	60	M22X2.0	SOMT 09...DP/DL/DK/DA D180-D181
2270-25T2-09	27.0	25	40	54	77	56	M16X1.5	
2270-32T2-09	27.0	32	40	54	77	60	M22X2.0	
2275-32T2-09	27.5	32	40	56	79	60	M22X2.0	
2280-25T2-09	28.0	25	40	56	79	56	M16X1.5	
2280-32T2-09	28.0	32	40	56	79	60	M22X2.0	
2285-32T2-09	28.5	32	40	58	81	60	M22X2.0	
2290-25T2-09	29.0	25	40	58	81	56	M16X1.5	
2290-32T2-09	29.0	32	40	58	81	60	M22X2.0	
2295-32T2-09	29.5	32	40	60	83	60	M22X2.0	
2300-32T2-09	30.0	32	40	60	83	60	M22X2.0	
2305-32T2-09	30.5	32	40	62	85	60	M22X2.0	
2310-32T2-09	31.0	32	40	62	85	60	M22X2.0	
2320-32T2-11	32.0	32	40	64	87	60	M22X2.0	
2320-40T2-11	32.0	40	50	64	87	70	M30X2.0	
2330-32T2-11	33.0	32	40	66	89	60	M22X2.0	
2330-40T2-11	33.0	40	50	66	89	70	M30X2.0	
2340-32T2-11	34.0	32	40	68	91	60	M22X2.0	
2340-40T2-11	34.0	40	50	68	91	70	M30X2.0	
2350-32T2-11	35.0	32	40	70	93	60	M22X2.0	
2350-40T2-11	35.0	40	50	70	93	70	M30X2.0	
2360-32T2-11	36.0	32	40	72	95	60	M22X2.0	
2360-40T2-11	36.0	40	50	72	95	70	M30X2.0	
2370-32T2-13	37.0	32	50	74	102	60	M22X2.0	SOMT 13...DP/DL/DK/DA D180-D181
2370-40T2-13	37.0	40	50	74	102	70	M30X2.0	
2380-32T2-13	38.0	32	50	76	104	60	M22X2.0	
2380-40T2-13	38.0	40	50	76	104	70	M30X2.0	
2390-32T2-13	39.0	32	50	78	106	60	M22X2.0	
2390-40T2-13	39.0	40	50	78	106	70	M30X2.0	
2400-32T2-13	40.0	32	50	80	108	60	M22X2.0	
2400-40T2-13	40.0	40	50	80	108	70	M30X2.0	
2410-40T2-13	41.0	40	50	82	110	70	M30X2.0	
2420-40T2-13	42.0	40	50	84	112	70	M30X2.0	
2430-40T2-13	43.0	40	50	86	114	70	M30X2.0	



► OAL: LPR+LS

TOP 2...-T2



Indexable drill holders



- Drilling depth: 2x diameter

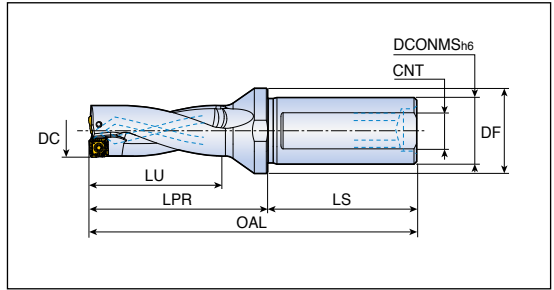

Designation	Dimension (mm)							Insert
	DC	DCONMS	DF	LU	LPR	LS	CNT	
TOP 2440-40T2-15	44.0	40	60	88	123	70	M30X2.0	SOMT 15...DP/DL/DK/DA D180-D181
2450-40T2-15	45.0	40	60	90	125	70	M30X2.0	
2460-40T2-15	46.0	40	60	92	127	70	M30X2.0	
2470-40T2-15	47.0	40	60	94	129	70	M30X2.0	
2480-40T2-15	48.0	40	60	96	131	70	M30X2.0	
2490-40T2-15	49.0	40	60	98	133	70	M30X2.0	
2500-40T2-15	50.0	40	60	100	135	70	M30X2.0	

► OAL: LPR+LS

Spare parts

Designation	Screw	Wrench	Plug*	
TOP 2120 - 2135	TS 18041/HG	TD 6P	SL 20M	
TOP 2140 - 2160	TS 20043/HG-P	TD 6P	SL 20M	
TOP 2165 - 2220	TS 22052/HG-P	TD 7P	SL 25M	
TOP 2225 - 2260	SO 25065I	TD 7	SL 25M / SL 32M	
TOP 2265 - 2360	TS 35088I	TD 10	SL 25M / SL 32M / SL 40M	
TOP 2370 - 2430	TS 40093I	TD 15	SL 32M / SL 40M	
TOP 2440 - 2550	TS 50115I	TD 20	SL 40M	



► * Notice: Cooling hole plug for lathe should be ordered separately
Order example) Plug for shank diameter 25.0mm: SL 25M

TOP 3...-T2



Indexable drill holders



- Drilling depth: 3x diameter

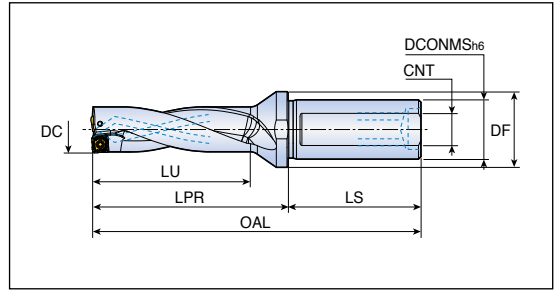

Designation	Dimension (mm)							Insert
	DC	DCONMS	DF	LU	LPR	LS	CNT	
TOP 3120-20T2-04	12.0	20	25	36	56	50	M13X1.0	SOMT 04...DP
3125-20T2-04	12.5	20	25	39	59	50	M13X1.0	D180
3130-20T2-04	13.0	20	25	39	59	50	M13X1.0	
3135-20T2-04	13.5	20	25	42	60	50	M13X1.0	
3140-20T2-05	14.0	20	25	42	60	50	M13X1.0	SOMT 05...DP/DL/DK/DA
3145-20T2-05	14.5	20	25	45	64	50	M13X1.0	D180-D181
3150-20T2-05	15.0	20	25	45	64	50	M13X1.0	
3155-20T2-05	15.5	20	25	48	68	50	M13X1.0	
3160-20T2-05	16.0	20	25	48	68	50	M13X1.0	
3165-25T2-06	16.5	25	32	51	71	56	M16X1.5	SOMT 06...DP/DL/DK/DA
3167-25T2-06 *	16.7	25	32	51	71	56	M16X1.5	D180-D181
3170-25T2-06	17.0	25	32	51	71	56	M16X1.5	
3175-25T2-06	17.5	25	32	54	75	56	M16X1.5	
3180-25T2-06	18.0	25	32	54	75	56	M16X1.5	
3185-25T2-06	18.5	25	32	57	78	56	M16X1.5	
3190-25T2-06	19.0	25	32	57	78	56	M16X1.5	
3195-25T2-07	19.5	25	32	60	83	56	M16X1.5	SOMT 07...DP/DL/DK/DA
3200-25T2-07	20.0	25	32	60	83	56	M16X1.5	D180-D181
3205-25T2-07	20.5	25	32	63	86	56	M16X1.5	
3210-25T2-07	21.0	25	32	63	86	56	M16X1.5	
3215-25T2-07	21.5	25	32	66	89	56	M16X1.5	
3220-25T2-07	22.0	25	32	66	89	56	M16X1.5	
3222-25T2-07 *	22.2	25	32	66	89	56	M16X1.5	
3225-25T2-08	22.5	25	32	69	91	56	M16X1.5	SOMT 08...DP/DL/DK/DA
3230-25T2-08	23.0	25	32	69	91	56	M16X1.5	D180-D181
3230-32T2-08	23.0	32	40	69	91	60	M22X2.0	
3235-25T2-08	23.5	25	32	72	94	56	M16X1.5	
3235-32T2-08	23.5	32	40	72	94	60	M22X2.0	
3240-25T2-08	24.0	25	32	72	94	56	M16X1.5	
3240-32T2-08	24.0	32	40	72	94	60	M22X2.0	
3245-25T2-08	24.5	25	32	75	97	56	M16X1.5	
3245-32T2-08	24.5	32	40	75	97	60	M22X2.0	
3250-25T2-08	25.0	25	32	75	97	56	M16X1.5	
3250-32T2-08	25.0	32	40	75	97	60	M22X2.0	
3254-25T2-08 *	25.4	25	32	75	97	56	M16X1.5	



- ▶ *: Inch sized hole
- ▶ OAL: LPR+LS

Indexable drill holders



- Drilling depth: 3x diameter

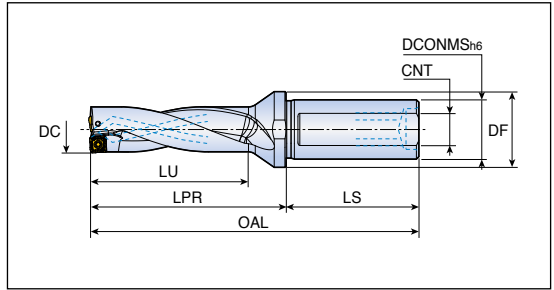

Designation	Dimension (mm)							Insert
	DC	DCONMS	DF	LU	LPR	LS	CNT	
TOP 3255-25T2-08	25.5	25	32	78	99	56	M16X1.5	SOMT 08...DP/DL/DK/DA D180-D181
3255-32T2-08	25.5	32	40	78	99	60	M22X2.0	
3260-25T2-08	26.0	25	32	78	99	56	M16X1.5	SOMT 09...DP/DL/DK/DA D180-D181
3260-32T2-08	26.0	32	32	78	99	60	M22X2.0	
3265-25T2-09	26.5	25	40	81	104	56	M16X1.5	SOMT 09...DP/DL/DK/DA D180-D181
3265-32T2-09	26.5	32	40	81	104	60	M22X2.0	
3270-25T2-09	27.0	25	40	81	104	56	M16X1.5	SOMT 11...DP/DL/DK/DA D180-D181
3270-32T2-09	27.0	32	40	81	104	60	M22X2.0	
3275-25T2-09	27.5	25	40	84	107	56	M16X1.5	SOMT 11...DP/DL/DK/DA D180-D181
3275-32T2-09	27.5	32	40	84	107	60	M22X2.0	
3280-25T2-09	28.0	25	40	84	107	56	M16X1.5	SOMT 13...DP/DL/DK/DA D180-D181
3280-32T2-09	28.0	32	40	84	107	60	M22X2.0	
3285-25T2-09	28.5	25	40	87	110	56	M16X1.5	SOMT 13...DP/DL/DK/DA D180-D181
3285-32T2-09	28.5	32	40	87	110	60	M22X2.0	
3290-25T2-09	29.0	25	40	87	110	56	M16X1.5	SOMT 13...DP/DL/DK/DA D180-D181
3290-32T2-09	29.0	32	40	87	110	60	M22X2.0	
3295-32T2-09	29.5	32	40	90	113	60	M22X2.0	SOMT 13...DP/DL/DK/DA D180-D181
3300-32T2-09	30.0	32	40	90	113	60	M22X2.0	
3305-32T2-09	30.5	32	40	93	116	60	M22X2.0	SOMT 13...DP/DL/DK/DA D180-D181
3310-32T2-09	31.0	32	40	93	116	60	M22X2.0	
3320-32T2-11	32.0	32	40	96	119	60	M22X2.0	SOMT 13...DP/DL/DK/DA D180-D181
3320-40T2-11	32.0	40	50	96	119	70	M30X2.0	
3330-32T2-11	33.0	32	40	99	122	60	M22X2.0	SOMT 13...DP/DL/DK/DA D180-D181
3330-40T2-11	33.0	40	50	99	122	70	M30X2.0	
3340-32T2-11	34.0	32	40	102	125	60	M22X2.0	SOMT 13...DP/DL/DK/DA D180-D181
3340-40T2-11	34.0	40	50	102	125	70	M30X2.0	
3350-32T2-11	35.0	32	40	105	128	60	M22X2.0	SOMT 13...DP/DL/DK/DA D180-D181
3350-40T2-11	35.0	40	50	105	128	70	M30X2.0	
3360-32T2-11	36.0	32	40	108	131	60	M22X2.0	SOMT 13...DP/DL/DK/DA D180-D181
3360-40T2-11	36.0	40	50	108	131	70	M30X2.0	
3370-32T2-13	37.0	32	50	111	139	60	M22X2.0	SOMT 13...DP/DL/DK/DA D180-D181
3370-40T2-13	37.0	40	50	111	139	70	M30X2.0	
3380-32T2-13	38.0	32	50	114	142	60	M22X2.0	SOMT 13...DP/DL/DK/DA D180-D181
3380-40T2-13	38.0	40	50	114	142	70	M30X2.0	
3390-32T2-13	39.0	32	50	117	145	60	M22X2.0	SOMT 13...DP/DL/DK/DA D180-D181



► OAL: LPR+LS

Indexable drill holders



- Drilling depth: 3x diameter

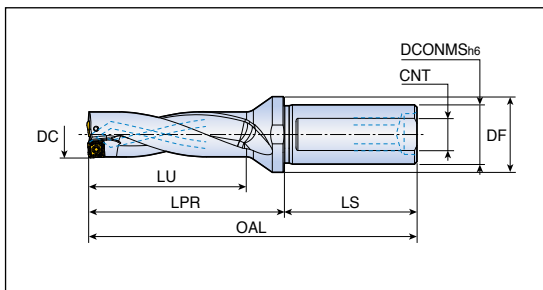

Designation	Dimension (mm)							Insert
	DC	DCONMS	DF	LU	LPR	LS	CNT	
TOP 3390-40T2-13	39.0	40	50	117	145	70	M30X2.0	SOMT 13...DP/DL/DK/DA D180-D181
3400-32T2-13	40.0	32	50	120	148	60	M22X2.0	
3400-40T2-13	40.0	40	50	120	148	70	M30X2.0	
3410-40T2-13	41.0	40	50	123	151	70	M30X2.0	
3420-40T2-13	42.0	40	50	126	154	70	M30X2.0	
3430-40T2-13	43.0	40	50	129	157	70	M30X2.0	
3440-40T2-15	44.0	40	60	132	167	70	M30X2.0	SOMT 15...DP/DL/DK/DA D180-D181
3450-40T2-15	45.0	40	60	135	170	70	M30X2.0	
3460-40T2-15	46.0	40	60	138	173	70	M30X2.0	
3470-40T2-15	47.0	40	60	141	176	70	M30X2.0	
3480-40T2-15	48.0	40	60	144	179	70	M30X2.0	
3490-40T2-15	49.0	40	60	147	182	70	M30X2.0	
3500-40T2-15	50.0	40	60	150	185	70	M30X2.0	

► OAL: LPR+LS

Spare parts

Designation	Screw	Wrench	Plug*	
TOP 3120 - 3135	TS 18041/HG	TD 6P	SL 20M	
TOP 3140 - 3160	TS 20043I/HG-P	TD 6P	SL 20M	
TOP 3165 - 3220	TS 22052I/HG-P	TD 7P	SL 25M	
TOP 3225 - 3260	SO 25065I	TD 7	SL 25M / SL 32M	
TOP 3265 - 3360	TS 35088I	TD 10	SL 25M / SL 32M / SL 40M	
TOP 3370 - 3430	TS 40093I	TD 15	SL 32M / SL 40M	
TOP 3440 - 3500	TS 50115I	TD 20	SL 40M	

► * Notice: Cooling hole plug for lathe should be ordered separately
 Order example) Plug for shank diameter 25.0mm: SL 25M



TOP 4...-T2



Indexable drill holders



- Drilling depth: 4x diameter

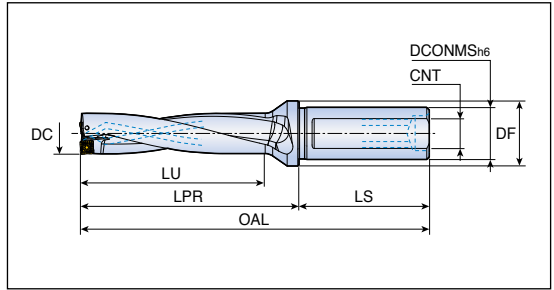

Designation	Dimension (mm)							Insert
	DC	DCONMS	DF	LU	LPR	LS	CNT	
TOP 4120-20T2-04	12.0	20	25	48	68	50	M13X1.0	SOMT 04...DP
4125-20T2-04	12.5	20	25	52	72	50	M13X1.0	D180
4130-20T2-04	13.0	20	25	52	72	50	M13X1.0	
4135-20T2-04	13.5	20	25	56	74	50	M13X1.0	
4140-20T2-05	14.0	20	25	56	74	50	M13X1.0	SOMT 05...DP/DL/DK/DA
4145-20T2-05	14.5	20	25	60	79	50	M13X1.0	D180-D181
4150-20T2-05	15.0	20	25	60	79	50	M13X1.0	
4155-20T2-05	15.5	20	25	64	84	50	M13X1.0	
4160-20T2-05	16.0	20	25	64	84	50	M13X1.0	
4165-25T2-06	16.5	25	32	68	88	56	M16X1.5	SOMT 06...DP/DL/DK/DA
4170-25T2-06	17.0	25	32	68	88	56	M16X1.5	D180-D181
4175-25T2-06	17.5	25	32	72	93	56	M16X1.5	
4180-25T2-06	18.0	25	32	72	93	56	M16X1.5	
4185-25T2-06	18.5	25	32	76	97	56	M16X1.5	
4190-25T2-06	19.0	25	32	76	97	56	M16X1.5	
4195-25T2-07	19.5	25	32	80	103	56	M16X1.5	SOMT 07...DP/DL/DK/DA
4200-25T2-07	20.0	25	32	80	103	56	M16X1.5	D180-D181
4205-25T2-07	20.5	25	32	84	107	56	M16X1.5	
4210-25T2-07	21.0	25	32	84	107	56	M16X1.5	
4215-25T2-07	21.5	25	32	88	111	56	M16X1.5	
4220-25T2-07	22.0	25	32	88	111	56	M16X1.5	
4225-25T2-08	22.5	25	32	92	114	56	M16X1.5	SOMT 08...DP/DL/DK/DA
4230-25T2-08	23.0	25	32	92	114	56	M16X1.5	D180-D181
4230-32T2-08	23.0	32	40	92	114	60	M22X2.0	
4235-25T2-08	23.5	25	32	96	118	56	M16X1.5	
4235-32T2-08	23.5	32	40	96	118	60	M22X2.0	
4240-25T2-08	24.0	25	32	96	118	56	M16X1.5	
4240-32T2-08	24.0	32	40	96	118	60	M22X2.0	
4245-25T2-08	24.5	25	32	100	122	56	M16X1.5	
4245-32T2-08	24.5	32	40	100	122	60	M22X2.0	
4250-25T2-08	25.0	25	32	100	122	56	M16X1.5	
4250-32T2-08	25.0	32	40	100	122	60	M22X2.0	
4254-25T2-08 *	25.4	25	32	100	122	56	M16X1.5	
4255-25T2-08	25.5	25	32	104	125	56	M16X1.5	
4255-32T2-08	25.5	32	40	104	125	60	M22X2.0	



- ▶ *: Inch sized hole
- ▶ OAL: LPR+LS

TOP 4...-T2

Indexable drill holders



- Drilling depth: 4x diameter

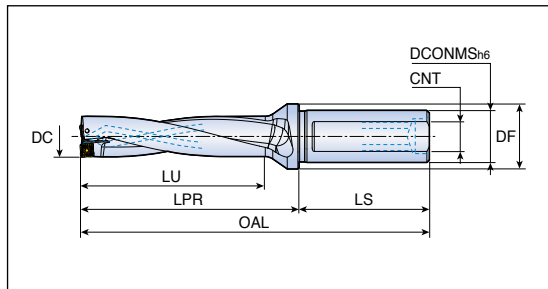

Designation	Dimension (mm)							Insert
	DC	DCONMS	DF	LU	LPR	LS	CNT	
TOP 4260-25T2-08	26.0	25	32	104	125	56	M16X1.5	SOMT 08...DP/DL/DK/DA D180-D181
4260-32T2-08	26.0	32	40	104	125	60	M22X2.0	
4265-25T2-09	26.5	25	40	108	131	56	M16X1.5	
4265-32T2-09	26.5	32	40	108	131	60	M22X2.0	
4270-25T2-09	27.0	25	40	108	131	56	M16X1.5	
4270-32T2-09	27.0	32	40	108	131	60	M22X2.0	
4275-25T2-09	27.5	25	40	112	135	56	M16X1.5	
4275-32T2-09	27.5	32	40	112	135	60	M22X2.0	
4280-25T2-09	28.0	25	40	112	135	56	M16X1.5	
4280-32T2-09	28.0	32	40	112	135	60	M22X2.0	
4285-25T2-09	28.5	25	40	116	139	56	M16X1.5	
4285-32T2-09	28.5	32	40	116	139	60	M22X2.0	
4286-32T2-09 *	28.6	32	40	116	139	60	M22X2.0	
4290-25T2-09	29.0	25	40	116	139	56	M16X1.5	
4290-32T2-09	29.0	32	40	116	139	60	M22X2.0	
4295-32T2-09	29.5	32	40	120	143	60	M22X2.0	
4300-32T2-09	30.0	32	40	120	143	60	M22X2.0	
4305-32T2-09	30.5	32	40	124	147	60	M22X2.0	
4310-32T2-09	31.0	32	40	124	147	60	M22X2.0	
4318-32T2-11 *	31.8	32	40	128	151	60	M22X2.0	SOMT 11...DP/DL/DK/DA D180-D181
4320-32T2-11	32.0	32	40	128	151	60	M22X2.0	
4320-40T2-11	32.0	40	50	128	151	70	M30X2.0	
4330-32T2-11	33.0	32	40	132	155	60	M22X2.0	
4330-40T2-11	33.0	40	50	132	155	70	M30X2.0	
4340-32T2-11	34.0	32	40	136	159	60	M22X2.0	
4340-40T2-11	34.0	40	50	136	159	70	M30X2.0	
4349-40T2-11 *	34.9	40	50	140	163	70	M30X2.0	
4350-32T2-11	35.0	32	40	140	163	60	M22X2.0	
4350-40T2-11	35.0	40	50	140	163	70	M30X2.0	
4360-32T2-11	36.0	32	40	144	167	60	M22X2.0	
4360-40T2-11	36.0	40	50	144	167	70	M30X2.0	
4370-32T2-13	37.0	32	50	148	176	60	M22X2.0	SOMT 13...DP/DL/DK/DA D180-D181
4370-40T2-13	37.0	40	50	148	176	70	M30X2.0	
4371-40T2-13 *	37.1	40	50	148	176	70	M30X2.0	



- ▶ *: Inch sized hole
- ▶ OAL: LPR+LS

Indexable drill holders



- Drilling depth: 4x diameter

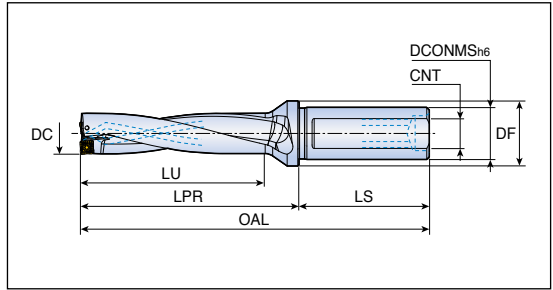

Designation	Dimension (mm)							Insert
	DC	DCONMS	DF	LU	LPR	LS	CNT	
TOP 4380-32T2-13	38.0	32	50	152	180	60	M22X2.0	SOMT 13...DP/DL/DK/DA D180-D181
4380-40T2-13	38.0	40	50	152	180	70	M30X2.0	
4381-40T2-13 *	38.1	40	50	152	180	70	M30X2.0	
4390-32T2-13	39.0	32	50	156	184	60	M22X2.0	
4390-40T2-13	39.0	40	50	156	184	70	M30X2.0	
4400-32T2-13	40.0	32	50	160	188	60	M22X2.0	
4400-40T2-13	40.0	40	50	160	188	70	M30X2.0	
4410-40T2-13	41.0	40	50	164	192	70	M30X2.0	
4413-40T2-13 *	41.3	40	50	164	192	70	M30X2.0	
4420-40T2-13	42.0	40	50	168	196	70	M30X2.0	
4429-40T2-13 *	42.9	40	50	172	200	70	M30X2.0	
4430-40T2-13	43.0	40	50	172	200	70	M30X2.0	
4440-40T2-15	44.0	40	60	176	211	70	M30X2.0	
4445-40T2-15 *	44.5	40	60	180	215	70	M30X2.0	
4450-40T2-15	45.0	40	60	180	215	70	M30X2.0	
4460-40T2-15	46.0	40	60	184	219	70	M30X2.0	
4470-40T2-15	47.0	40	60	188	223	70	M30X2.0	
4476-40T2-15 *	47.6	40	60	192	227	70	M30X2.0	
4480-40T2-15	48.0	40	60	192	227	70	M30X2.0	
4490-40T2-15	49.0	40	60	196	231	70	M30X2.0	
4500-40T2-15	50.0	40	60	200	235	70	M30X2.0	
4508-40T2-15 *	50.8	40	60	204	239	70	M30X2.0	

▶ * Marked items are for inch sized hole

▶ OAL = LPR+LS

Spare parts

Designation	Screw 	Wrench 	Plug* 	
TOP 4120 - 4135	TS 18041/HG	TD 6P	SL 20M	
TOP 4140 - 4160	TS 20043I/HG-P	TD 6P	SL 20M	
TOP 4165 - 4220	TS 22052I/HG-P	TD 7P	SL 25M	
TOP 4225 - 4260	SO 25065I	TD 7	SL 25M / SL 32M	
TOP 4265 - 4360	TS 35088I	TD 10	SL 25M / SL 32M / SL 40M	
TOP 4370 - 4430	TS 40093I	TD 15	SL 32M / SL 40M	
TOP 4440 - 4508	TS 50115I	TD 20	SL 40M	



▶ * Notice: Cooling hole plug for lathe should be ordered separately
Order example) Plug for shank diameter 25.0mm: SL 25M

Indexable drill holders

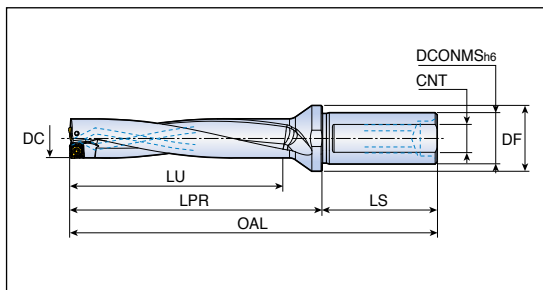

- Drilling depth: 5x diameter



Designation	Dimension (mm)							Insert
	DC	DCONMS	DF	LU	LPR	LS	CNT	
TOP 5120-20T2-04	12.0	20	25	60	80	50	M13X1.0	SOMT 04...DP
5125-20T2-04	12.5	20	25	65	85	50	M13X1.0	D180
5130-20T2-04	13.0	20	25	65	85	50	M13X1.0	
5135-20T2-04	13.5	20	25	70	88	50	M13X1.0	
5140-20T2-05	14.0	20	25	70	88	50	M13X1.0	SOMT 05...DP/DL/DK/DA
5145-20T2-05	14.5	20	25	75	94	50	M13X1.0	D180-D181
5150-20T2-05	15.0	20	25	75	94	50	M13X1.0	
5155-20T2-05	15.5	20	25	80	100	50	M13X1.0	
5160-20T2-05	16.0	20	25	80	100	50	M13X1.0	
5165-25T2-06	16.5	25	32	85	105	56	M16X1.5	SOMT 06...DP/DL/DK/DA
5170-25T2-06	17.0	25	32	85	105	56	M16X1.5	D180-D181
5175-25T2-06	17.5	25	32	90	111	56	M16X1.5	
5180-25T2-06	18.0	25	32	90	111	56	M16X1.5	
5185-25T2-06	18.5	25	32	95	116	56	M16X1.5	
5190-25T2-06	19.0	25	32	95	116	56	M16X1.5	
5195-25T2-07	19.5	25	32	100	123	56	M16X1.5	SOMT 07...DP/DL/DK/DA
5200-25T2-07	20.0	25	32	100	123	56	M16X1.5	D180-D181
5205-25T2-07	20.5	25	32	105	128	56	M16X1.5	
5210-25T2-07	21.0	25	32	105	128	56	M16X1.5	
5215-25T2-07	21.5	25	32	110	133	56	M16X1.5	
5220-25T2-07	22.0	25	32	110	133	56	M16X1.5	
5222-25T2-07 *	22.2	25	32	110	133	56	M16X1.5	
5225-25T2-08	22.5	25	32	115	137	56	M16X1.5	SOMT 08...DP/DL/DK/DA
5230-25T2-08	23.0	25	32	115	137	56	M16X1.5	D180-D181
5230-32T2-08	23.0	32	40	115	137	60	M22X2.0	
5235-25T2-08	23.5	25	32	120	142	56	M16X1.5	
5235-32T2-08	23.5	32	40	120	142	60	M22X2.0	
5240-25T2-08	24.0	25	32	120	142	56	M16X1.5	
5240-32T2-08	24.0	32	40	120	142	60	M22X2.0	
5245-25T2-08	24.5	25	32	125	147	56	M16X1.5	
5245-32T2-08	24.5	32	40	125	147	60	M22X2.0	
5250-25T2-08	25.0	25	32	125	147	56	M16X1.5	
5250-32T2-08	25.0	32	40	125	147	60	M22X2.0	
5255-25T2-08	25.5	25	32	130	151	56	M16X1.5	
5255-32T2-08	25.5	32	40	130	151	60	M22X2.0	



- ▶ *: Inch sized hole
- ▶ OAL: LPR+LS

TOP 5...-T2



Indexable drill holders



- Drilling depth: 5x diameter

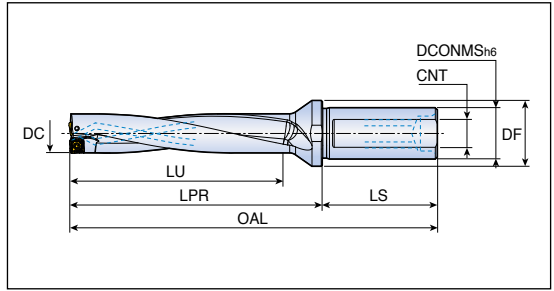

Designation	Dimension (mm)							Insert
	DC	DCONMS	DF	LU	LPR	LS	CNT	
TOP 5260-25T2-08	26.0	25	32	130	151	56	M16X1.5	SOMT 08...DP/DL/DK/DA
5260-32T2-08	26.0	32	40	130	151	60	M22X2.0	D180-D181
5265-32T2-09	26.5	32	40	135	158	60	M22X2.0	SOMT 09...DP/DL/DK/DA
5270-25T2-09	27.0	25	40	135	158	56	M16X1.5	D180-D181
5270-32T2-09	27.0	32	40	135	158	60	M22X2.0	
5275-32T2-09	27.5	32	40	140	163	60	M22X2.0	
5280-25T2-09	28.0	25	40	140	163	56	M16X1.5	
5280-32T2-09	28.0	32	40	140	163	60	M22X2.0	
5282-32T2-09 *	28.2	32	40	140	163	60	M22X2.0	
5285-32T2-09	28.5	32	40	145	168	60	M22X2.0	
5290-25T2-09	29.0	25	40	145	168	56	M16X1.5	
5290-32T2-09	29.0	32	40	145	168	60	M22X2.0	
5295-32T2-09	29.5	32	40	150	173	60	M22X2.0	
5300-32T2-09	30.0	32	40	150	173	60	M22X2.0	
5305-32T2-09	30.5	32	40	155	178	60	M22X2.0	
5310-32T2-09	31.0	32	40	155	178	60	M22X2.0	
5320-32T2-11	32.0	32	40	160	183	60	M22X2.0	SOMT 11...DP/DL/DK/DA
5320-40T2-11	32.0	40	50	160	183	70	M30X2.0	D180-D181
5330-32T2-11	33.0	32	40	165	188	60	M22X2.0	
5330-40T2-11	33.0	40	50	165	188	70	M30X2.0	
5340-32T2-11	34.0	32	40	170	193	60	M22X2.0	
5340-40T2-11	34.0	40	50	170	193	70	M30X2.0	
5350-32T2-11	35.0	32	40	175	198	60	M22X2.0	
5350-40T2-11	35.0	40	50	175	198	70	M30X2.0	
5360-32T2-11	36.0	32	40	180	203	60	M22X2.0	
5360-40T2-11	36.0	40	50	180	203	70	M30X2.0	
5370-32T2-13	37.0	32	50	185	213	60	M22X2.0	SOMT 13...DP/DL/DK/DA
5370-40T2-13	37.0	40	50	185	213	70	M30X2.0	D180-D181
5380-32T2-13	38.0	32	50	190	218	60	M22X2.0	
5380-40T2-13	38.0	40	50	190	218	70	M30X2.0	
5390-32T2-13	39.0	32	50	195	223	60	M22X2.0	
5390-40T2-13	39.0	40	50	195	223	70	M30X2.0	
5400-32T2-13	40.0	32	50	200	228	60	M22X2.0	
5400-40T2-13	40.0	40	50	200	228	70	M30X2.0	



- ▶ *: Inch sized hole
- ▶ OAL: LPR+LS

Indexable drill holders



- Drilling depth: 5x diameter

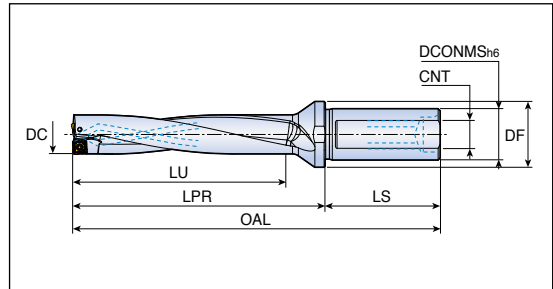

Designation	Dimension (mm)							Insert
	DC	DCONMS	DF	LU	LPR	LS	CNT	
TOP 5410-40T2-13	41.0	40	50	205	233	70	M30X2.0	SOMT 13...DP/DL/DK/DA
5420-40T2-13	42.0	40	50	210	238	70	M30X2.0	D180-D181
5430-40T2-13	43.0	40	50	215	243	70	M30X2.0	
5440-40T2-15	44.0	40	60	220	255	70	M30X2.0	SOMT 15...DP/DL/DK/DA
5450-40T2-15	45.0	40	60	225	260	70	M30X2.0	D180-D181
5460-40T2-15	46.0	40	60	230	265	70	M30X2.0	
5470-40T2-15	47.0	40	60	235	270	70	M30X2.0	
5480-40T2-15	48.0	40	60	240	275	70	M30X2.0	
5490-40T2-15	49.0	40	60	245	280	70	M30X2.0	
5500-40T2-15	50.0	40	60	250	285	70	M30X2.0	

► OAL: LPR+LS

Spare parts

Designation	Screw 	Wrench 	Plug* 	
TOP 5120 - 5135	TS 18041/HG	TD 6P	SL 20M	
TOP 5140 - 5160	TS 200431/HG-P	TD 6P	SL 20M	
TOP 5165 - 5220	TS 220521/HG-P	TD 7P	SL 25M	
TOP 5225 - 5260	SO 25065I	TD 7	SL 25M / SL 32M	
TOP 5265 - 5360	TS 35088I	TD 10	SL 25M / SL 32M / SL 40M	
TOP 5370 - 5430	TS 40093I	TD 15	SL 32M / SL 40M	
TOP 5440 - 5500	TS 50115I	TD 20	SL 40M	



► * Notice: Cooling hole plug for lathe should be ordered separately
 Order example) Plug for shank diameter 25.0mm: SL 25M

TOP 20...CA



Indexable drill holders for cartridge



- Drilling depth: 2x diameter

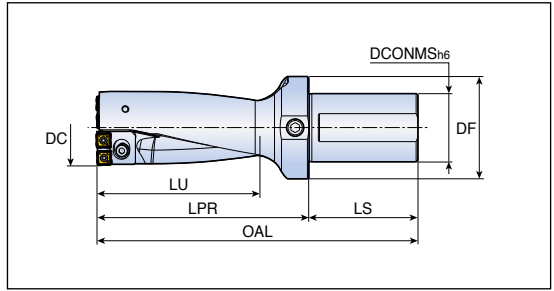

Designation	Dimension (mm)							Setting Plate	Insert
	DC	DCONMS	DF	OAL	LU	LPR	LS		
TOP 2051-55-50T2-09CA	51	50	64	223	110	143	80	-	SOMT 09...
	52	50	64	223	110	143	80	TOP-0901	DP/DL/DK/DA
	53	50	64	223	110	143	80	TOP-0902	D180-D181
	54	50	64	223	110	143	80	TOP-0903	
	55	50	64	223	110	143	80	TOP-0904	
TOP 2056-60-50T2-11CA	56	50	64	236	120	156	80	-	SOMT 11...
	57	50	64	236	120	156	80	TOP-0901	DP/DL/DK/DA
	58	50	64	236	120	156	80	TOP-0902	D180-D181
	59	50	64	236	120	156	80	TOP-0903	
	60	50	64	236	120	156	80	TOP-0904	
TOP 2061-65-50T2-11CA	61	50	69	249	130	169	80	-	SOMT 11...
	62	50	69	249	130	169	80	TOP-0901	DP/DL/DK/DA
	63	50	69	249	130	169	80	TOP-0902	D180-D181
	64	50	69	249	130	169	80	TOP-0903	
	65	50	69	249	130	169	80	TOP-0904	
TOP 2066-70-50T2-11CA	66	50	69	262	140	182	80	-	SOMT 11...
	67	50	69	262	140	182	80	TOP-0901	DP/DL/DK/DA
	68	50	69	262	140	182	80	TOP-0902	D180-D181
	69	50	69	262	140	182	80	TOP-0903	
	70	50	69	262	140	182	80	TOP-0904	
TOP 2071-75-50T2-13CA	71	50	74	275	150	195	80	-	SOMT 13...
	72	50	74	275	150	195	80	TOP-0901	DP/DL/DK/DA
	73	50	74	275	150	195	80	TOP-0902	D180-D181
	74	50	74	275	150	195	80	TOP-0903	
	75	50	74	275	150	195	80	TOP-0904	
TOP 2076-80-50T2-13CA	76	50	74	288	160	208	80	-	SOMT 13...
	77	50	74	288	160	208	80	TOP-0901	DP/DL/DK/DA
	78	50	74	288	160	208	80	TOP-0902	D180-D181
	79	50	74	288	160	208	80	TOP-0903	
	80	50	74	288	160	208	80	TOP-0904	



► OAL: LPR+LS

TOP 30...CA



Indexable drill holders for cartridge



- Drilling depth: 3xdiameter

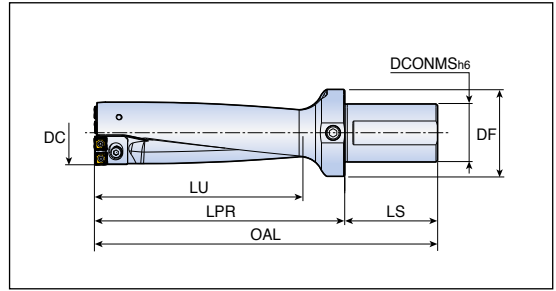

Designation	Dimension (mm)							Setting Plate	Insert
	DC	DCONMS	DF	OAL	LU	LPR	LS		
TOP 3051-55-50T2-09CA	51	50	64	278	165	198	80	-	SOMT 09... DP/DL/DK/DA
	52	50	64	278	165	198	80	TOP-0901	D180-D181
	53	50	64	278	165	198	80	TOP-0902	
	54	50	64	278	165	198	80	TOP-0903	
	55	50	64	278	165	198	80	TOP-0904	
TOP 3056-60-50T2-11CA	56	50	64	296	180	216	80	-	
	57	50	64	296	180	216	80	TOP-0901	D180-D181
	58	50	64	296	180	216	80	TOP-0902	
	59	50	64	296	180	216	80	TOP-0903	
	60	50	64	296	180	216	80	TOP-0904	
TOP 3061-65-50T2-11CA	61	50	69	314	195	234	80	-	
	62	50	69	314	195	234	80	TOP-0901	D180-D181
	63	50	69	314	195	234	80	TOP-0902	
	64	50	69	314	195	234	80	TOP-0903	
	65	50	69	314	195	234	80	TOP-0904	
TOP 3066-70-50T2-11CA	66	50	69	332	210	252	80	-	
	67	50	69	332	210	252	80	TOP-0901	D180-D181
	68	50	69	332	210	252	80	TOP-0902	
	69	50	69	332	210	252	80	TOP-0903	
	70	50	69	332	210	252	80	TOP-0904	
TOP 3071-75-50T2-13CA	71	50	74	350	225	270	80	-	
	72	50	74	350	225	270	80	TOP-0901	D180-D181
	73	50	74	350	225	270	80	TOP-0902	
	74	50	74	350	225	270	80	TOP-0903	
	75	50	74	350	225	270	80	TOP-0904	
TOP 3076-80-50T2-13CA	76	50	74	368	240	288	80	-	
	77	50	74	368	240	288	80	TOP-0901	D180-D181
	78	50	74	368	240	288	80	TOP-0902	
	79	50	74	368	240	288	80	TOP-0903	
	80	50	74	368	240	288	80	TOP-0904	

Cutting Condition ▶ OAL: LPR+LS
D230

TOP 40...CA



Indexable drill holders for cartridge



• Drilling depth: 4x diameter

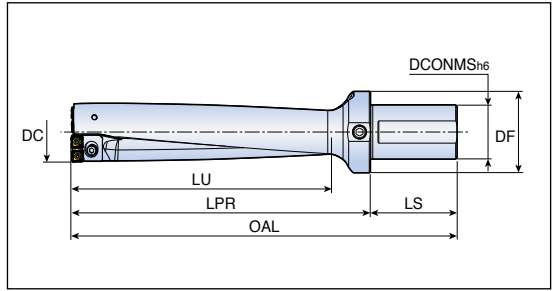

Designation	Dimension (mm)							Setting Plate	Insert
	DC	DCONMS	DF	OAL	LU	LPR	LS		
TOP 4051-55-50T2-09CA	51	50	64	333	220	253	80	-	SOMT 09...
	52	50	64	333	220	253	80	TOP-0901	DP/DL/DK/DA
	53	50	64	333	220	253	80	TOP-0902	D180-D181
	54	50	64	333	220	253	80	TOP-0903	
	55	50	64	333	220	253	80	TOP-0904	
TOP 4056-60-50T2-11CA	56	50	64	356	240	276	80	-	SOMT 11...
	57	50	64	356	240	276	80	TOP-0901	DP/DL/DK/DA
	58	50	64	356	240	276	80	TOP-0902	D180-D181
	59	50	64	356	240	276	80	TOP-0903	
	60	50	64	356	240	276	80	TOP-0904	
TOP 4061-65-50T2-11CA	61	50	69	379	260	299	80	-	SOMT 11...
	62	50	69	379	260	299	80	TOP-0901	DP/DL/DK/DA
	63	50	69	379	260	299	80	TOP-0902	D180-D181
	64	50	69	379	260	299	80	TOP-0903	
	65	50	69	379	260	299	80	TOP-0904	
TOP 4066-70-50T2-11CA	66	50	69	402	280	322	80	-	SOMT 11...
	67	50	69	402	280	322	80	TOP-0901	DP/DL/DK/DA
	68	50	69	402	280	322	80	TOP-0902	D180-D181
	69	50	69	402	280	322	80	TOP-0903	
	70	50	69	402	280	322	80	TOP-0904	
TOP 4071-75-50T2-13CA	71	50	74	425	300	345	80	-	SOMT 13...
	72	50	74	425	300	345	80	TOP-0901	DP/DL/DK/DA
	73	50	74	425	300	345	80	TOP-0902	D180-D181
	74	50	74	425	300	345	80	TOP-0903	
	75	50	74	425	300	345	80	TOP-0904	
TOP 4076-80-50T2-13CA	76	50	74	448	320	368	80	-	SOMT 13...
	77	50	74	448	320	368	80	TOP-0901	DP/DL/DK/DA
	78	50	74	448	320	368	80	TOP-0902	D180-D181
	79	50	74	448	320	368	80	TOP-0903	
	80	50	74	448	320	368	80	TOP-0904	



► OAL: LPR+LS

Indexable drill holders for cartridge

Spare parts

Designation	Screw	Cartridge for peripheral	Cartridge for center
TOP ..51-55-50T2-09CA	TS 35088I	TOP 09CA-P1	TOP 09CA-C1
TOP ..56-60-50T2-11CA	TS 35088I	TOP 11CA-P1	TOP 11CA-C1
TOP ..61-65-50T2-11CA	TS 35088I	TOP 11CA-P2	TOP 11CA-C2
TOP ..66-70-50T2-11CA	TS 35088I	TOP 11CA-P3	TOP 11CA-C3
TOP ..71-75-50T2-13CA	TS 40093I	TOP 13CA-P1	TOP 13CA-C1
TOP ..76-80-50T2-13CA	TS 40093I	TOP 13CA-P2	TOP 13CA-C2

Spare parts for cartridge

Designation	Cartridge clamping screw	Washer	Setting plate screw
TOP 09CA-P1	SH M4x0.7x16	MW 4.3x8	TS 20043I/HG-P
TOP 09CA-C1	SH M4x0.7x16	MW 4.3x8	-
TOP 11CA-P1	SH M5x0.8x16	MW 5.5x10	TS 20043I/HG-P
TOP 11CA-C1	SH M5x0.8x16	MW 5.5x10	-
TOP 11CA-P2	SH M5x0.8x16	MW 5.5x10	TS 20043I/HG-P
TOP 11CA-C2	SH M5x0.8x16	MW 5.5x10	-
TOP 11CA-P3	SH M5x0.8x16	MW 5.5x10	TS 20043I/HG-P
TOP 11CA-C3	SH M5x0.8x16	MW 5.5x10	-
TOP 13CA-P1	SH M6x1.0x20	MW 6.4x12	TS 20043I/HG-P
TOP 13CA-C1	SH M6x1.0x20	MW 6.4x12	-
TOP 13CA-P2	SH M6x1.0x20	MW 6.4x12	TS 20043I/HG-P
TOP 13CA-C2	SH M6x1.0x20	MW 6.4x12	-

TDR 2...-T2



Indexable drill holders



- Drilling depth: 2x diameter

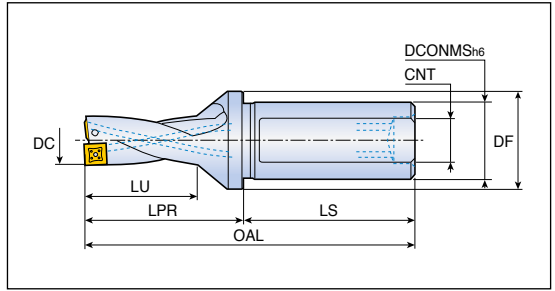

Designation	Dimension (mm)							Insert
	DC	DCONMS	DF	LU	LPR	LS	CNT	
TDR 2125-20T2-05	12.5	20	25	26	44	50	M13X1.0	SPMG 05...
2130-20T2-05	13.0	20	25	26	44	50	M13X1.0	DG/DK
2135-20T2-05	13.5	20	25	28	46	50	M13X1.0	SPGG 05..DA
2140-20T2-05	14.0	20	25	28	46	50	M13X1.0	D182-D183
2145-20T2-05	14.5	20	25	30	49	50	M13X1.0	
2150-20T2-05	15.0	20	25	30	49	50	M13X1.0	
2155-25T2-06	15.5	25	32	32	52	56	M16X1.5	SPMG 06...
2160-25T2-06	16.0	25	32	32	52	56	M16X1.5	DG/DK
2165-25T2-06	16.5	25	32	34	54	56	M16X1.5	SPGG 06..DA
2170-25T2-06	17.0	25	32	34	54	56	M16X1.5	D182-D183
2175-25T2-06	17.5	25	32	36	57	56	M16X1.5	
2180-25T2-06	18.0	25	32	36	57	56	M16X1.5	
2185-25T2-06	18.5	25	32	38	59	56	M16X1.5	
2190-25T2-06	19.0	25	32	38	59	56	M16X1.5	
2195-25T2-06	19.5	25	32	40	63	56	M16X1.5	
2200-25T2-06	20.0	25	32	40	63	56	M16X1.5	
2205-25T2-06	20.5	25	32	42	65	56	M16X1.5	
2210-25T2-06	21.0	25	32	42	65	56	M16X1.5	
2215-25T2-06	21.5	25	32	44	67	56	M16X1.5	
2220-25T2-07	22.0	25	32	44	67	56	M16X1.5	SPMG 07...
2225-25T2-07	22.5	25	32	46	71	56	M16X1.5	DG/DK
2225-32T2-07	22.5	32	40	46	71	60	M22X2.0	SPGG 07..DA
2230-25T2-07	23.0	25	32	46	71	56	M16X1.5	D182-D183
2230-32T2-07	23.0	32	40	46	71	60	M22X2.0	
2235-25T2-07	23.5	25	32	48	74	56	M16X1.5	
2235-32T2-07	23.5	32	40	48	74	60	M22X2.0	
2240-25T2-07	24.0	25	32	48	74	56	M16X1.5	
2240-32T2-07	24.0	32	40	48	74	60	M22X2.0	
2245-25T2-07	24.5	25	32	50	77	56	M16X1.5	
2245-32T2-07	24.5	32	40	50	77	60	M22X2.0	
2250-25T2-07	25.0	25	32	50	77	56	M16X1.5	
2250-32T2-07	25.0	32	40	50	77	60	M22X2.0	
2255-25T2-07	25.5	25	32	52	79	56	M16X1.5	
2255-32T2-07	25.5	32	40	52	79	60	M22X2.0	
2260-25T2-07	26.0	25	32	52	79	56	M16X1.5	



► OAL: LPR+LS

TDR 2...-T2



Indexable drill holders



- Drilling depth: 2x diameter

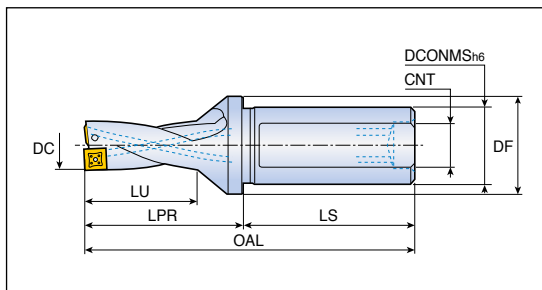

Designation	Dimension (mm)							Insert
	DC	DCONMS	DF	LU	LPR	LS	CNT	
TDR 2260-32T2-07	26.0	32	40	52	79	60	M22X2.0	SPMG 07... DG/DK SPGG 07..DA D182-D183
2265-25T2-07	26.5	25	32	54	81	56	M16X1.5	
2265-32T2-07	26.5	32	40	54	81	60	M22X2.0	
2270-25T2-07	27.0	25	32	54	81	56	M16X1.5	
2270-32T2-07	27.0	32	40	54	81	60	M22X2.0	
2275-25T2-07	27.5	25	32	56	84	56	Rc 1/8	
2275-32T2-07	27.5	32	40	56	84	60	Rc 1/4	SPMG 09... DG/DK SPGG 09..DA D182-D183
2280-25T2-09	28.0	25	40	56	84	56	Rc 1/8	
2280-32T2-09	28.0	32	40	56	84	60	Rc 1/4	
2285-25T2-09	28.5	25	40	58	86	56	Rc 1/8	
2285-32T2-09	28.5	32	40	58	86	60	Rc 1/4	
2290-25T2-09	29.0	25	40	58	86	56	Rc 1/8	
2290-32T2-09	29.0	32	40	58	86	60	Rc 1/4	
2295-32T2-09	29.5	32	40	60	91	60	Rc 1/4	
2295-40T2-09	29.5	40	50	60	91	70	Rc 1/4	
2300-32T2-09	30.0	32	40	60	91	60	Rc 1/4	
2300-40T2-09	30.0	40	50	60	91	70	Rc 1/4	
2305-32T2-09	30.5	32	40	62	94	60	Rc 1/4	
2305-40T2-09	30.5	40	50	62	94	70	Rc 1/4	
2310-32T2-09	31.0	32	40	62	94	60	Rc 1/4	
2310-40T2-09	31.0	40	50	62	94	70	Rc 1/4	
2315-32T2-09	31.5	32	40	64	96	60	Rc 1/4	
2315-40T2-09	31.5	40	50	64	96	70	Rc 1/4	
2320-32T2-09	32.0	32	40	64	96	60	Rc 1/4	
2320-40T2-09	32.0	40	50	64	96	70	Rc 1/4	
2325-32T2-09	32.5	32	40	66	99	60	Rc 1/4	
2325-40T2-09	32.5	40	50	66	99	70	Rc 1/4	
2330-32T2-09	33.0	32	40	66	99	60	Rc 1/4	
2330-40T2-09	33.0	40	50	66	99	70	Rc 1/4	
2340-32T2-11	34.0	32	50	68	101	60	Rc 1/4	SPMG 11... DG/DK SPGG 11..DA D182-D183
2340-40T2-11	34.0	40	55	68	101	70	Rc 1/4	
2350-32T2-11	35.0	32	50	70	104	60	Rc 1/4	
2350-40T2-11	35.0	40	55	70	104	70	Rc 1/4	
2360-32T2-11	36.0	32	50	72	107	60	Rc 1/4	
2360-40T2-11	36.0	40	55	72	107	70	Rc 1/4	

► OAL: LPR+LS



TDR 2...-T2



Indexable drill holders



- Drilling depth: 2x diameter

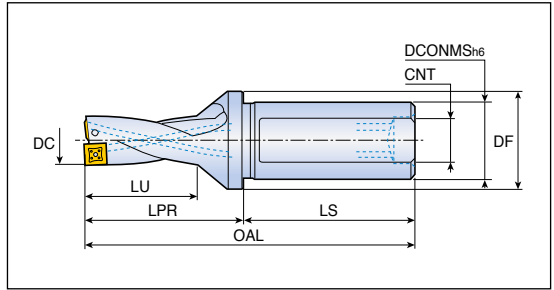

Designation	Dimension (mm)							Insert
	DC	DCONMS	DF	LU	LPR	LS	CNT	
TDR 2370-32T2-11	37.0	32	50	74	110	60	Rc 1/4	SPMG 11... DG/DK SPGG 11..DA D182-D183
2370-40T2-11	37.0	40	55	74	110	70	Rc 1/4	
2380-32T2-11	38.0	32	50	76	113	60	Rc 1/4	
2380-40T2-11	38.0	40	55	76	113	70	Rc 1/4	
2390-32T2-11	39.0	32	50	78	115	60	Rc 1/4	
2390-40T2-11	39.0	40	55	78	115	70	Rc 1/4	
2400-32T2-11	40.0	32	50	80	118	60	Rc 1/4	
2400-40T2-11	40.0	40	55	80	118	70	Rc 1/4	
2410-40T2-11	41.0	40	55	82	121	70	Rc 1/4	
2420-40T2-14	42.0	40	60	84	123	70	Rc 1/4	
2430-40T2-14	43.0	40	60	86	126	70	Rc 1/4	
2440-40T2-14	44.0	40	60	88	128	70	Rc 1/4	
2450-40T2-14	45.0	40	60	90	132	70	Rc 1/4	
2460-40T2-14	46.0	40	60	92	135	70	Rc 1/4	
2470-40T2-14	47.0	40	60	94	137	70	Rc 1/4	
2480-40T2-14	48.0	40	60	96	140	70	Rc 1/4	
2490-40T2-14	49.0	40	60	98	142	70	Rc 1/4	
2500-40T2-14	50.0	40	60	100	145	70	Rc 1/4	

► OAL: LPR+LS

Spare parts

Designation	Screw	Wrench	Plug*	
TDR 2125 - 2150	TS 20043I/HG-P	TD 6P	SL 20 M	
TDR 2155 - 2215	TS 22052I/HG	TD 7	SL 25 M	
TDR 2220 - 2270	TS 25064I	TD 8	SL 25 M / SL 32 M	
TDR 2275	TS 25064I	TD 8	-	
TDR 2280 - 2330	TS 35088I	TD 10	-	
TDR 2340 - 2390	TS 40093I	TD 15	-	
TDR 2400 - 2410	TS 40093I	TD 15	-	
TDR 2420 - 2500	SO 50090I	TD 20	-	

- * Notice: Cooling hole plug for lathe should be ordered separately
 Order example) Plug for shank diameter 25.0mm: SL 25M



D232

TDR 3...-T2



Indexable drill holders



- Drilling depth: 3x diameter

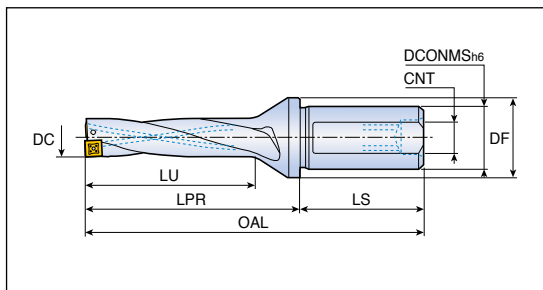

Designation	Dimension (mm)							Insert
	DC	DCONMS	DF	LU	LPR	LS	CNT	
TDR 3125-20T2-05	12.5	20	25	39	57	50	M13X1.0	SPMG 05...
3130-20T2-05	13.0	20	25	39	57	50	M13X1.0	DG/DK
3135-20T2-05	13.5	20	25	42	60	50	M13X1.0	SPGG 05..DA
3140-20T2-05	14.0	20	25	42	60	50	M13X1.0	D182-D183
3145-20T2-05	14.5	20	25	45	64	50	M13X1.0	
3150-20T2-05	15.0	20	25	45	64	50	M13X1.0	
3155-25T2-06	15.5	25	32	48	68	56	M16X1.5	SPMG 06...
3160-25T2-06	16.0	25	32	48	68	56	M16X1.5	DG/DK
3165-25T2-06	16.5	25	32	51	71	56	M16X1.5	SPGG 06..DA
3170-25T2-06	17.0	25	32	51	71	56	M16X1.5	D182-D183
3175-25T2-06	17.5	25	32	54	75	56	M16X1.5	
3180-25T2-06	18.0	25	32	54	75	56	M16X1.5	
3185-25T2-06	18.5	25	32	57	78	56	M16X1.5	
3190-25T2-06	19.0	25	32	57	78	56	M16X1.5	
3195-25T2-06	19.5	25	32	60	83	56	M16X1.5	
3200-25T2-06 *	20.0	25	32	60	83	56	M16X1.5	
3205-25T2-06	20.5	25	32	63	86	56	M16X1.5	
3209-25T2-06 *	20.9	25	32	63	86	56	M16X1.5	
3210-25T2-06	21.0	25	32	63	86	56	M16X1.5	
3215-25T2-06	21.5	25	32	66	89	56	M16X1.5	
3220-25T2-07	22.0	25	32	66	89	56	M16X1.5	SPMG 07...
3225-25T2-07	22.5	25	32	69	94	56	M16X1.5	DG/DK
3225-32T2-07	22.5	32	40	69	94	60	M22X2.0	SPGG 07..DA
3230-25T2-07	23.0	25	32	69	94	56	M16X1.5	D182-D183
3230-32T2-07	23.0	32	40	69	94	60	M22X2.0	
3235-25T2-07	23.5	25	32	72	98	56	M16X1.5	
3235-32T2-07	23.5	32	40	72	98	60	M22X2.0	
3239-25T2-07 *	23.9	25	32	72	98	56	M16X1.5	
3239-32T2-07 *	23.9	32	45	72	98	60	M22X2.0	
3240-25T2-07	24.0	25	32	72	98	56	M16X1.5	
3240-32T2-07	24.0	32	40	72	98	60	M22X2.0	
3245-25T2-07	24.5	25	32	75	102	56	M16X1.5	
3245-32T2-07	24.5	32	40	75	102	60	M22X2.0	
3250-25T2-07	25.0	25	32	75	102	56	M16X1.5	
3250-32T2-07	25.0	32	40	75	102	60	M22X2.0	



- ▶ *: Pre-thread hole making
- ▶ OAL: LPR+LS

TDR 3...-T2



Indexable drill holders



- Drilling depth: 3xdiameter

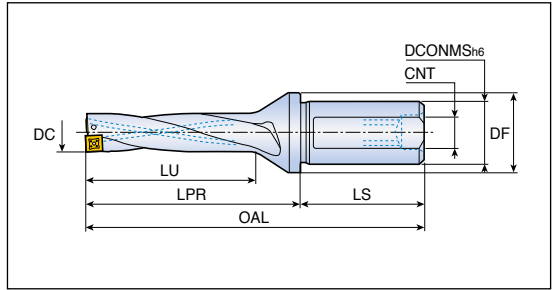

Designation	Dimension (mm)							Insert
	DC	DCONMS	DF	LU	LPR	LS	CNT	
TDR 3255-25T2-07	25.5	25	32	78	105	56	M16X1.5	SPMG 07... DG/DK SPGG 07..DA D182-D183
3255-32T2-07	25.5	32	40	78	105	60	M22X2.0	
3260-25T2-07	26.0	25	32	78	105	56	M16X1.5	
3260-32T2-07	26.0	32	40	78	105	60	M22X2.0	
3264-25T2-07 *	26.4	25	45	81	108	56	M16X1.5	
3264-32T2-07 *	26.4	32	45	81	108	60	M22X2.0	
3265-25T2-07	26.5	25	32	81	108	56	M16X1.5	
3265-32T2-07	26.5	32	40	81	108	60	M22X2.0	
3270-25T2-07	27.0	25	32	81	108	56	M16X1.5	
3270-32T2-07	27.0	32	40	81	108	60	M22X2.0	
3275-25T2-07	27.5	25	32	84	112	56	Rc 1/8	
3275-32T2-07	27.5	32	40	84	112	60	Rc 1/4	
3280-25T2-09	28.0	25	40	84	112	56	Rc 1/8	SPMG 09... DG/DK SPGG 09..DA D182-D183
3280-32T2-09	28.0	32	40	84	112	60	Rc 1/4	
3285-25T2-09	28.5	25	40	87	115	56	Rc 1/8	
3285-32T2-09	28.5	32	40	87	115	56	Rc 1/4	
3290-25T2-09	29.0	25	40	87	115	56	Rc 1/8	
3290-32T2-09	29.0	32	40	87	115	60	Rc 1/4	
3294-32T2-09 *	29.4	32	55	90	121	60	Rc 1/4	
3294-40T2-09 *	29.4	40	55	90	121	70	Rc 1/4	
3295-32T2-09	29.5	32	40	90	121	60	Rc 1/4	
3295-40T2-09	29.5	40	50	90	121	70	Rc 1/4	
3300-32T2-09	30.0	32	40	90	121	60	Rc 1/4	
3300-40T2-09	30.0	40	50	90	121	70	Rc 1/4	
3305-32T2-09	30.5	32	40	93	125	60	Rc 1/4	
3305-40T2-09	30.5	40	50	93	125	70	Rc 1/4	
3310-32T2-09	31.0	32	40	93	125	60	Rc 1/4	
3310-40T2-09	31.0	40	50	93	125	70	Rc 1/4	
3315-32T2-09	31.5	32	40	96	128	60	Rc 1/4	
3315-40T2-09	31.5	40	50	96	128	70	Rc 1/4	
3320-32T2-09	32.0	32	40	96	128	60	Rc 1/4	
3320-40T2-09	32.0	40	50	96	128	70	Rc 1/4	



- ▶ *: Pre-thread hole making
- ▶ OAL: LPR+LS

TDR 3...-T2



Indexable drill holders



- Drilling depth: 3xdiameter

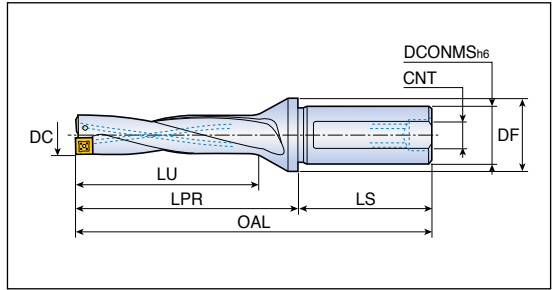

Designation	Dimension (mm)							Insert
	DC	DCONMS	DF	LU	LPR	LS	CNT	
TDR 3420-40T2-14	42.0	40	60	126	165	70	Rc 1/4	SPMG 14...
3430-40T2-14	43.0	40	60	129	169	70	Rc 1/4	DG/DK
3440-40T2-14	44.0	40	60	132	172	70	Rc 1/4	SPGG 14..DA
3450-40T2-14	45.0	40	60	135	177	70	Rc 1/4	D182-D183
3460-40T2-14	46.0	40	60	138	181	70	Rc 1/4	
3470-40T2-14	47.0	40	60	141	184	70	Rc 1/4	
3480-40T2-14	48.0	40	60	144	188	70	Rc 1/4	
3490-40T2-14	49.0	40	60	147	191	70	Rc 1/4	
3500-40T2-14	50.0	40	60	150	195	70	Rc 1/4	

► OAL: LPR+LS

Spare parts

Designation	Screw	Wrench	Plug*	
TDR 3125 - 3150	TS 20043I/HG-P	TD 6P	SL 20 M	
TDR 3155 - 3215	TS 22052I/HG	TD 7	SL 25 M	
TDR 3220 - 3270	TS 25064I	TD 8	SL 25 M / SL 32 M	
TDR 3275	TS 25064I	TD 8	-	
TDR 3280 - 3330	TS 35088I	TD 10	-	
TDR 3340 - 3390	TS 40093I	TD 15	-	
TDR 3400 - 3410	TS 40093I	TD 15	-	
TDR 3420 - 3500	SO 50090I	TD 20	-	



► * Notice: Cooling hole plug for lathe should be ordered separately
 Order example) Plug for shank diameter 25.0mm : SL 25M

Indexable drill holders



- Drilling depth: 4x diameter

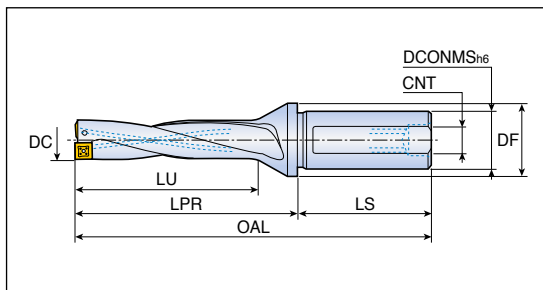

Designation	Dimension (mm)							Insert
	DC	DCONMS	DF	LU	LPR	LS	CNT	
TDR 4125-20T2-05	12.5	20	25	52	70	50	M13X1.0	SPMG 05...
4130-20T2-05	13.0	20	25	52	70	50	M13X1.0	DG/DK
4135-20T2-05	13.5	20	25	56	74	50	M13X1.0	SPGG 05..DA
4140-20T2-05	14.0	20	25	56	74	50	M13X1.0	D182-D183
4145-20T2-05	14.5	20	25	60	79	50	M13X1.0	
4150-20T2-05	15.0	20	25	60	79	50	M13X1.0	
4155-25T2-06	15.5	25	32	64	84	56	M16X1.5	SPMG 06...
4160-25T2-06	16.0	25	32	64	84	56	M16X1.5	DG/DK
4165-25T2-06	16.5	25	32	68	88	56	M16X1.5	SPGG 06..DA
4170-25T2-06	17.0	25	32	68	88	56	M16X1.5	D182-D183
4175-25T2-06	17.5	25	32	72	93	56	M16X1.5	
4180-25T2-06	18.0	25	32	72	93	56	M16X1.5	
4185-25T2-06	18.5	25	32	76	97	56	M16X1.5	
4190-25T2-06	19.0	25	32	76	97	56	M16X1.5	
4195-25T2-06	19.5	25	32	80	103	56	M16X1.5	
4200-25T2-06	20.0	25	32	80	103	56	M16X1.5	
4205-25T2-06	20.5	25	32	84	107	56	M16X1.5	
4210-25T2-06	21.0	25	32	84	107	56	M16X1.5	
4215-25T2-06	21.5	25	32	88	111	56	M16X1.5	
4220-25T2-07	22.0	25	32	88	111	56	M16X1.5	SPMG 07...
4225-25T2-07	22.5	25	32	92	117	56	M16X1.5	DG/DK
4225-32T2-07	22.5	32	40	92	117	60	M22X2.0	SPGG 07..DA
4230-25T2-07	23.0	25	32	92	117	56	M16X1.5	D182-D183
4230-32T2-07	23.0	32	40	92	117	60	M22X2.0	
4235-25T2-07	23.5	25	32	96	122	56	M16X1.5	
4235-32T2-07	23.5	32	40	96	122	60	M22X2.0	
4240-25T2-07	24.0	25	32	96	122	56	M16X1.5	
4240-32T2-07	24.0	32	40	96	122	60	M22X2.0	
4245-25T2-07	24.5	25	32	100	127	56	M16X1.5	
4245-32T2-07	24.5	32	40	100	127	60	M22X2.0	
4250-25T2-07	25.0	25	32	100	127	56	M16X1.5	
4250-32T2-07	25.0	32	40	100	127	60	M22X2.0	
4255-25T2-07	25.5	25	32	104	131	56	M16X1.5	
4255-32T2-07	25.5	32	40	104	131	60	M22X2.0	
4260-25T2-07	26.0	25	32	104	131	56	M16X1.5	



► OAL: LPR+LS

TDR 4...-T2



Indexable drill holders



- Drilling depth: 4x diameter

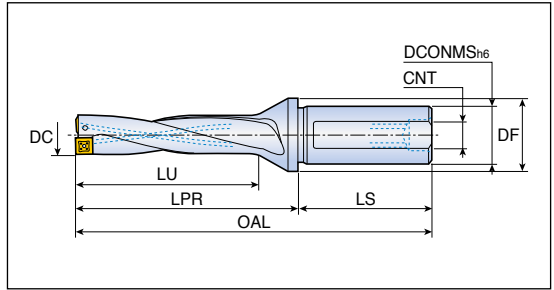

Designation	Dimension (mm)							Insert
	DC	DCONMS	DF	LU	LPR	LS	CNT	
TDR 4260-32T2-07	26.0	32	40	104	131	60	M22X2.0	SPMG 07...
4265-25T2-07	26.5	25	32	108	135	56	M16X1.5	DG/DK
4265-32T2-07	26.5	32	40	108	135	60	M22X2.0	SPGG 07..DA
4270-25T2-07	27.0	25	32	108	135	56	M16X1.5	D182-D183
4270-32T2-07	27.0	32	40	108	135	60	M22X2.0	
4275-25T2-07	27.5	25	32	112	140	56	Rc 1/8	
4275-32T2-07	27.5	32	40	112	140	60	Rc 1/4	
4280-25T2-09	28.0	25	40	112	140	56	Rc 1/8	SPMG 09...
4280-32T2-09	28.0	32	40	112	140	60	Rc 1/4	DG/DK
4285-25T2-09	28.5	25	40	116	144	56	Rc 1/8	SPGG 09..DA
4285-32T2-09	28.5	32	40	116	144	60	Rc 1/4	D182-D183
4290-25T2-09	29.0	25	40	116	144	56	Rc 1/8	
4290-32T2-09	29.0	32	40	116	144	60	Rc 1/4	
4295-32T2-09	29.5	32	40	120	151	60	Rc 1/4	
4295-40T2-09	29.5	40	50	120	151	70	Rc 1/4	
4300-32T2-09	30.0	32	40	120	151	60	Rc 1/4	
4300-40T2-09	30.0	40	50	120	151	70	Rc 1/4	
4305-32T2-09	30.5	32	40	124	156	60	Rc 1/4	
4305-40T2-09	30.5	40	50	124	156	70	Rc 1/4	
4310-32T2-09	31.0	32	40	124	156	60	Rc 1/4	
4310-40T2-09	31.0	40	50	124	156	70	Rc 1/4	
4315-32T2-09	31.5	32	40	128	160	60	Rc 1/4	
4315-40T2-09	31.5	40	50	128	160	70	Rc 1/4	
4320-32T2-09	32.0	32	40	128	160	60	Rc 1/4	
4320-40T2-09	32.0	40	50	128	160	70	Rc 1/4	
4325-32T2-09	32.5	32	40	132	165	60	Rc 1/4	
4325-40T2-09	32.5	40	50	132	165	70	Rc 1/4	
4330-32T2-09	33.0	32	40	132	165	60	Rc 1/4	
4330-40T2-09	33.0	40	50	132	165	70	Rc 1/4	
4340-32T2-11	34.0	32	50	136	169	60	Rc 1/4	SPMG 11...
4340-40T2-11	34.0	40	55	136	169	70	Rc 1/4	DG/DK
4350-32T2-11	35.0	32	50	140	174	60	Rc 1/4	SPGG 11..DA
4350-40T2-11	35.0	40	55	140	174	70	Rc 1/4	D182-D183
4360-32T2-11	36.0	32	50	144	179	60	Rc 1/4	
4360-40T2-11	36.0	40	55	144	179	70	Rc 1/4	

Cutting Condition D232 ▶ OAL: LPR+LS

TDR 4...-T2



Indexable drill holders



- Drilling depth: 4xdiameter

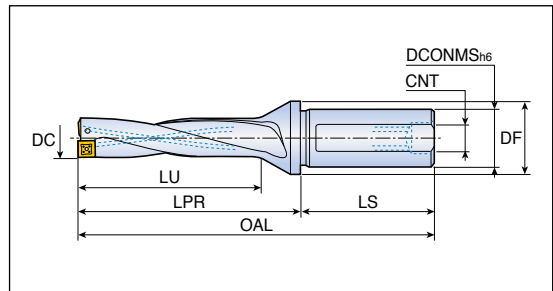

Designation	Dimension (mm)							Insert
	DC	DCONMS	DF	LU	LPR	LS	CNT	
TDR 4370-32T2-11	37.0	32	50	148	184	60	Rc 1/4	SPMG 11...
4370-40T2-11	37.0	40	55	148	184	70	Rc 1/4	DG/DK
4380-32T2-11	38.0	32	50	152	189	60	Rc 1/4	SPGG 11..DA
4380-40T2-11	38.0	40	55	152	189	70	Rc 1/4	D182-D183
4390-32T2-11	39.0	32	50	156	193	60	Rc 1/4	
4390-40T2-11	39.0	40	55	156	193	70	Rc 1/4	
4400-32T2-11	40.0	32	50	160	198	60	Rc 1/4	
4400-40T2-11	40.0	40	55	160	198	70	Rc 1/4	
4410-40T2-11	41.0	40	55	164	203	70	Rc 1/4	
4420-40T2-14	42.0	40	60	168	207	70	Rc 1/4	SPMG 14...
4430-40T2-14	43.0	40	60	172	212	70	Rc 1/4	DG/DK
4440-40T2-14	44.0	40	60	176	216	70	Rc 1/4	SPGG 14..DA
4450-40T2-14	45.0	40	60	180	222	70	Rc 1/4	D182-D183
4460-40T2-14	46.0	40	60	184	227	70	Rc 1/4	
4470-40T2-14	47.0	40	60	188	231	70	Rc 1/4	
4480-40T2-14	48.0	40	60	192	236	70	Rc 1/4	
4490-40T2-14	49.0	40	60	196	240	70	Rc 1/4	
4500-40T2-14	50.0	40	60	200	245	70	Rc 1/4	

► OAL = LPR+LS

Spare parts

Designation	Screw 	Wrench 	Plug* 	
TDR 4125 - 4150	TS 20043I/HG-P	TD 6P	SL 20 M	
TDR 4155 - 4215	TS 22052I/HG	TD 7	SL 25 M	
TDR 4220 - 4270	TS 25064I	TD 8	SL 25 M / SL 32 M	
TDR 4275	TS 25064I	TD 8	-	
TDR 4280 - 4330	TS 35088I	TD 10	-	
TDR 4340 - 4390	TS 40093I	TD 15	-	
TDR 4400 - 4410	TS 40093I	TD 15	-	
TDR 4420 - 4500	SO 50090I	TD 20	-	

► * Notice: Cooling hole plug for lathe should be ordered separately
 Order example) Plug for shank diameter 25.0mm: SL 25M



TDR 5...-T2



Indexable drill holders



- Drilling depth: 5x diameter

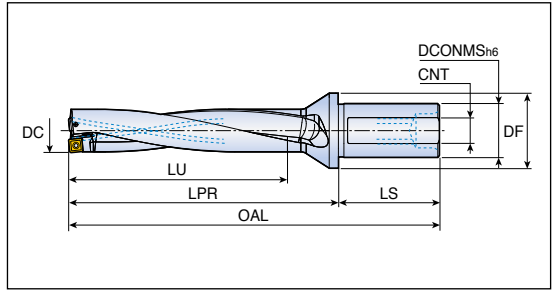

Designation	Dimension (mm)							Insert
	DC	DCONMS	DF	LU	LPR	LS	CNT	
TDR 5125-20T2-05	12.5	20	25	65	83	50	M13X1.0	SPMG 05...
5130-20T2-05	13.0	20	25	65	83	50	M13X1.0	DG/DK
5135-20T2-05	13.5	20	25	70	88	50	M13X1.0	SPGG 05..DA
5140-20T2-05	14.0	20	25	70	88	50	M13X1.0	D182-D183
5145-20T2-05	14.5	20	25	75	94	50	M13X1.0	
5150-20T2-05	15.0	20	25	75	94	50	M13X1.0	
5155-25T2-06	15.5	25	32	80	100	56	M16X1.5	SPMG 06...
5160-25T2-06	16.0	25	32	80	100	56	M16X1.5	DG/DK
5165-25T2-06	16.5	25	32	85	105	56	M16X1.5	SPGG 06..DA
5170-25T2-06	17.0	25	32	85	105	56	M16X1.5	D182-D183
5175-25T2-06	17.5	25	32	90	111	56	M16X1.5	
5180-25T2-06	18.0	25	32	90	111	56	M16X1.5	
5185-25T2-06	18.5	25	32	95	116	56	M16X1.5	
5190-25T2-06	19.0	25	32	95	116	56	M16X1.5	
5195-25T2-06	19.5	25	32	100	123	56	M16X1.5	
5200-25T2-06	20.0	25	32	100	123	56	M16X1.5	
5205-25T2-06	20.5	25	32	105	128	56	M16X1.5	
5210-25T2-06	21.0	25	32	105	128	56	M16X1.5	
5215-25T2-06	21.5	25	32	110	133	56	M16X1.5	
5220-25T2-07	22.0	25	32	110	133	56	M22X2.0	SPMG 07...
5225-32T2-07	22.5	32	40	115	140	60	M22X2.0	DG/DK
5230-32T2-07	23.0	32	40	115	140	60	M22X2.0	SPGG 07..DA
5235-32T2-07	23.5	32	40	120	146	60	M22X2.0	D182-D183
5240-32T2-07	24.0	32	40	120	146	60	M22X2.0	
5245-32T2-07	24.5	32	40	125	152	60	M22X2.0	
5250-32T2-07	25.0	32	40	125	152	60	M22X2.0	
5255-32T2-07	25.5	32	40	130	157	60	M22X2.0	
5260-32T2-07	26.0	32	40	130	157	60	M22X2.0	
5265-32T2-07	26.5	32	40	135	162	60	M22X2.0	
5270-32T2-07	27.0	32	40	135	162	60	M22X2.0	
5275-32T2-07	27.5	32	40	140	168	60	Rc 1/4	



► OAL: LPR + LS

TDR 5...-T2



Indexable drill holders



- Drilling depth: 5x diameter

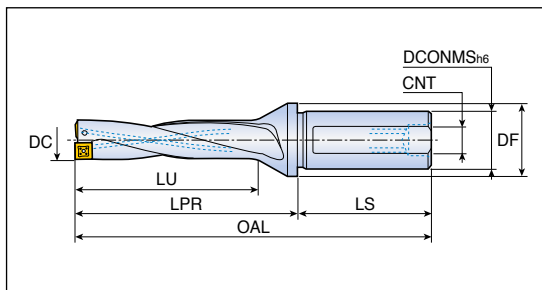

Designation	Dimension (mm)							Insert	
	DC	DCONMS	DF	LU	LPR	LS	CNT		
TDR 5280-32T2-09	28.0	32	40	140	168	60	Rc 1/4	SPMG 09... DG/DK SPGG 09..DA D182-D183	
5285-32T2-09	28.5	32	40	145	173	60	Rc 1/4		
5290-32T2-09	29.0	32	40	145	173	60	Rc 1/4		
5295-32T2-09	29.5	32	40	150	181	60	Rc 1/4		
5300-32T2-09	30.0	32	40	150	181	60	Rc 1/4		
5300-40T2-09	30.0	40	50	150	181	70	Rc 1/4		
5310-32T2-09	31.0	32	40	155	187	60	Rc 1/4		
5310-40T2-09	31.0	40	50	155	187	70	Rc 1/4		
5320-32T2-09	32.0	32	40	160	192	60	Rc 1/4		
5320-40T2-09	32.0	40	50	160	192	70	Rc 1/4		
5330-32T2-09	33.0	32	40	165	198	60	Rc 1/4		
5330-40T2-09	33.0	40	50	165	198	70	Rc 1/4		
5340-32T2-11	34.0	32	50	170	203	60	Rc 1/4		SPMG 11... DG/DK SPGG 11..DA D182-D183
5340-40T2-11	34.0	40	55	170	203	70	Rc 1/4		
5350-32T2-11	35.0	32	50	175	209	60	Rc 1/4		
5350-40T2-11	35.0	40	55	175	209	70	Rc 1/4		
5360-32T2-11	36.0	32	50	180	215	60	Rc 1/4		
5360-40T2-11	36.0	40	55	180	215	70	Rc 1/4		
5370-32T2-11	37.0	32	50	185	221	60	Rc 1/4		
5370-40T2-11	37.0	40	55	185	221	70	Rc 1/4		
5380-32T2-11	38.0	32	50	190	227	60	Rc 1/4		
5380-40T2-11	38.0	40	55	190	227	70	Rc 1/4		
5390-32T2-11	39.0	32	50	195	232	60	Rc 1/4		
5390-40T2-11	39.0	40	55	195	232	70	Rc 1/4		
5400-32T2-11	40.0	32	50	200	238	60	Rc 1/4		
5400-40T2-11	40.0	40	55	200	238	70	Rc 1/4		
5410-40T2-11	41.0	40	55	205	244	70	Rc 1/4		

Cutting Condition **D234** ▶ OAL: LPR+LS

TDR 5...-T2



Indexable drill holders



- Drilling depth: 5x diameter

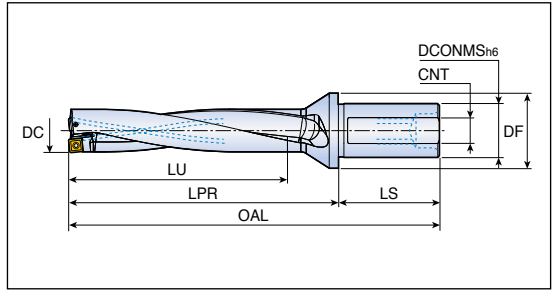

Designation	Dimension (mm)							Insert
	DC	DCONMS	DF	LU	LPR	LS	CNT	
TDR 5420-40T2-14	42.0	40	60	210	249	70	Rc 1/4	SPMG 14...
5430-40T2-14	43.0	40	60	215	255	70	Rc 1/4	DG/DK
5440-40T2-14	44.0	40	60	220	260	70	Rc 1/4	SPGG 14..DA
5450-40T2-14	45.0	40	60	225	267	70	Rc 1/4	D182-D183
5460-40T2-14	46.0	40	60	230	273	70	Rc 1/4	
5470-40T2-14	47.0	40	60	235	278	70	Rc 1/4	
5480-40T2-14	48.0	40	60	240	284	70	Rc 1/4	
5490-40T2-14	49.0	40	60	245	289	70	Rc 1/4	
5500-40T2-14	50.0	40	60	250	295	70	Rc 1/4	

► OAL: LPR+LS

Spare parts

Designation	Screw	Wrench	Plug*	
TDR 5125 - 5150	TS 20043I/HG-P	TD 6P	SL 20 M	
TDR 5155 - 5215	TS 22052I/HG	TD 7	SL 25 M	
TDR 5220 - 5270	TS 25064I	TD 8	SL 25 M / SL 32 M	
TDR 5275	TS 25064I	TD 8	-	
TDR 5280 - 5330	TS 35088I	TD 10	-	
TDR 5340 - 5390	TS 40093I	TD 15	-	
TDR 5400 - 5410	TS 40093I	TD 15	-	
TDR 5420 - 5500	SO 50090I	TD 20	-	



► * Notice: Cooling hole plug for lathe should be ordered separately
Order example) Plug for shank diameter 25.0mm: SL 25M

TDR 25...CA-T



Indexable cartridge drill holders



- Drilling depth: 2.5x diameter

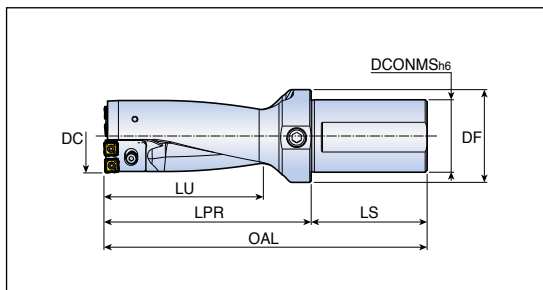

Designation	Dimension (mm)						Setting plate	Insert
	DC	DCONMS	DF	LU	LPR	LS		
TDR 2551-53-50T2-07CA-T	51	50	64	133	170	80	-	SPMG 07... DG/DK SPGG 07..DA D182-D183
	52	50	64	133	170	80	TDP-0701	
	53	50	64	133	170	80	TDP-0702	
2554-56-50T2-07CA-T	54	50	64	140	180	80	-	SPMG 07... DG/DK SPGG 07..DA D182-D183
	55	50	64	140	180	80	TDP-0701	
	56	50	64	140	180	80	TDP-0702	
2557-62-50T2-09CA-T	57	50	64	155	201	80	-	SPMG 09... DG/DK SPGG 09..DA D182-D183
	58	50	64	155	201	80	TDP-0901	
	59	50	64	155	201	80	TDP-0902	
	60	50	64	155	201	80	TDP-0903	
	61	50	64	155	201	80	TDP-0904	
	62	50	64	155	201	80	TDP-0905	
2563-66-50T2-09CA-T	63	50	69	165	215	80	-	SPMG 09... DG/DK SPGG 09..DA D182-D183
	64	50	69	165	215	80	TDP-0901	
	65	50	69	165	215	80	TDP-0902	
	66	50	69	165	215	80	TDP-0903	
2567-73-50T2-11CA-T	67	50	69	183	240	80	-	SPMG 11... DG/DK SPGG 11..DA D182-D183
	68	50	69	183	240	80	TDP-1101	
	69	50	69	183	240	80	TDP-1102	
	70	50	69	183	240	80	TDP-1103	
	71	50	69	183	240	80	TDP-1104	
	72	50	69	183	240	80	TDP-1105	
	73	50	69	183	240	80	TDP-1106	
2574-80-50T2-12CA-T	74	50	74	200	250	80	-	SPMG 12...DG D182
	75	50	74	200	250	80	TDP-1101	
	76	50	74	200	250	80	TDP-1102	
	77	50	74	200	250	80	TDP-1103	
	78	50	74	200	250	80	TDP-1104	
	79	50	74	200	250	80	TDP-1105	
	80	50	74	200	250	80	TDP-1106	



► OAL: LPR+LS

TDR 35...CA-T



Indexable cartridge drill holders



- Drilling depth: 3.5xdiameter

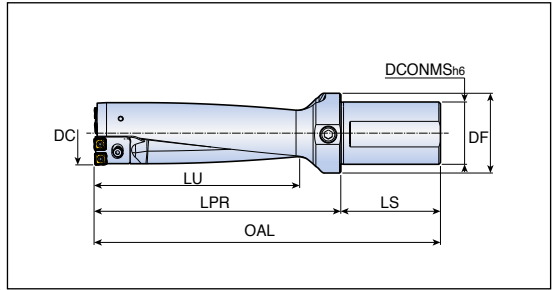

Designation	Dimension (mm)						Setting plate	Insert
	DC	DCONMS	DF	LU	LPR	LS		
TDR 3551-53-50T2-07CA-T	51	50	64	186	223	80	-	SPMG 07...
	52	50	75	186	223	80	TDP-0701	DG/DK SPGG 07..DA
	53	50	75	186	223	80	TDP-0702	SPGG 07..DA D182-D183
3554-56-50T2-07CA-T	54	50	75	196	236	80	-	SPMG 07...
	55	50	75	196	236	80	TDP-0701	DG/DK SPGG 07..DA
	56	50	75	196	236	80	TDP-0702	SPGG 07..DA D182-D183
3557-62-50T2-09CA-T	57	50	75	217	263	80	-	SPMG 09...
	58	50	75	217	263	80	TDP-0901	DG/DK
	59	50	75	217	263	80	TDP-0902	SPGG 09..DA
	60	50	75	217	263	80	TDP-0903	D182-D183
	61	50	75	217	263	80	TDP-0904	
	62	50	75	217	263	80	TDP-0905	
3563-66-50T2-09CA-T	63	50	75	231	281	80	-	SPMG 09...
	64	50	75	231	281	80	TDP-0901	DG/DK
	65	50	75	231	281	80	TDP-0902	SPGG 09..DA
	66	50	75	231	281	80	TDP-0903	D182-D183
3567-73-50T2-11CA-T	67	50	75	256	313	80	-	SPMG 11...
	68	50	75	256	313	80	TDP-1101	DG/DK
	69	50	75	256	313	80	TDP-1102	SPGG 11..DA
	70	50	75	256	313	80	TDP-1103	D182-D183
	71	50	75	256	313	80	TDP-1104	
	72	50	75	256	313	80	TDP-1105	
	73	50	75	256	313	80	TDP-1106	



► OAL: LPR+LS

TDR 35...CA-T



Indexable cartridge drill holders



- Drilling depth: 3.5x diameter

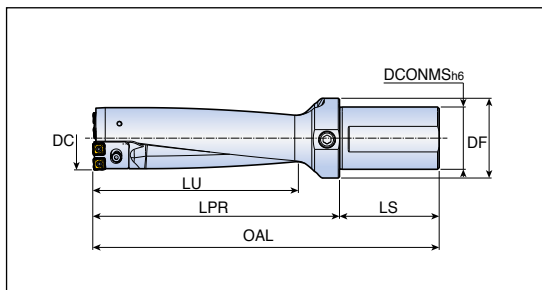

Designation	Dimension (mm)						Setting plate	Insert
	DC	DCONMS	DF	LU	LPR	LS		
TDR 3574-80-50T2-12CA-T	74	50	75	280	330	80	-	SPMG 12...DG D182
	75	50	75	280	330	80	TDP-1101	
	76	50	75	280	330	80	TDP-1102	
	77	50	75	280	330	80	TDP-1103	
	78	50	75	280	330	80	TDP-1104	
	79	50	75	280	330	80	TDP-1105	
80	50	75	280	330	80	TDP-1106		

▶ OAL: LPR+LS

Spare parts

Designation	Screw	Cartridge for peripheral	Cartridge for center
TDR.. 51-53...	TS 250641	TDR 07CA-P1-T	TDR 07CA-C1-T
TDR.. 54-56...	TS 250641	TDR 07CA-P2-T	TDR 07CA-C2-T
TDR.. 57-62...	TS 350881	TDR 09CA-P1-T	TDR 09CA-C1-T
TDR.. 63-66...	TS 350881	TDR 09CA-P2-T	TDR 09CA-C2-T
TDR.. 67-73...	TS 400931	TDR 11CA-P1-T	TDR 11CA-C1-T
TDR.. 74-80...	TS 400931	TDR 12CA-P2-T	TDR 12CA-C2-T

Spare parts for cartridges

Designation	Cartridge clamping screw	Washer	Setting plate screw
TDR 07CA-P1-T	SH M4x0.7x16	MW 4.3x8	TS 20043I/HG-P
TDR 07CA-C1-T	SH M4x0.7x16	MW 4.3x8	-
TDR 07CA-P2-T	SH M4x0.7x16	MW 4.3x8	TS 20043I/HG-P
TDR 07CA-C2-T	SH M4x0.7x16	MW 4.3x8	-
TDR 09CA-P1-T	SH M5x0.8x16	MW 5.5x10	SO 30055I
TDR 09CA-C1-T	SH M5x0.8x16	MW 5.5x10	-
TDR 09CA-P2-T	SH M5x0.8x16	MW 5.5x10	SO 30055I
TDR 09CA-C2-T	SH M5x0.8x16	MW 5.5x10	-
TDR 11CA-P1-T	SH M6x1.0x20	MW 6.4x12	SO 30055I
TDR 11CA-C1-T	SH M6x1.0x20	MW 6.4x12	-
TDR 12CA-P2-T	SH M6x1.0x20	MW 6.4x12	SO 30055I
TDR 12CA-C2-T	SH M6x1.0x20	MW 6.4x12	-



TCAP...-2.25DN



Multi-function toolholders - 2.25xD



• Internal coolant

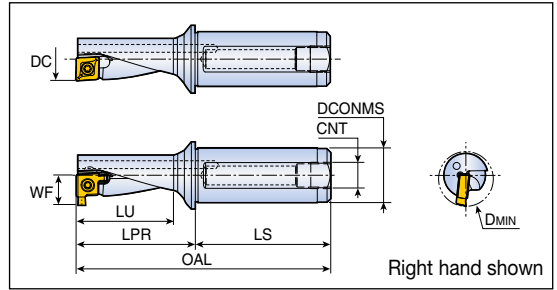
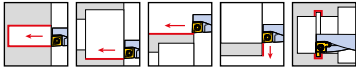

Designation	Dimension (mm)								Insert	
	DC	DCONMS	WF	LU	LPR	LS	DMIN	CNT	For drilling, boring, turning	For grooving
TCAP 08R/L-2.25DN	8	12	-	18.0	22.5	42	-	G 1/16	XCM(G)T 04...TC/TA	-
10R/L-2.25DN-GV	10	12	7.1	22.5	27.5	42	12.0	G 1/16	XCM(G)T 05...TC/TA	XCMT 05R...GV
12R/L-2.25DN-GV	12	16	8.5	27.0	33.0	45	14.5	G 1/8	XCM(G)T 06...TC/TA	XCMT 06R...GV
14R/L-2.25DN-GV	14	16	9.5	31.5	38.5	45	16.5	G 1/8	XCM(G)T 07...TC/TA	XCMT 07R...GV
16R/L-2.25DN-GV	16	20	11.1	36.0	44.0	50	19.0	G 1/8	XCM(G)T 08...TC/TA	XCMT 08R...GV
20R/L-2.25DN-GV	20	25	13.2	45.0	55.0	56	23.5	G 1/8	XCM(G)T 10...TC/TA	XCMT 10R...GV
25R/L-2.25DN-GV	25	32	16.5	56.2	69.0	61	29.0	G 1/8	XCM(G)T 13...TC/TA	XCMT 13R...GV
32R/L-2.25DN-GV	32	40	20.5	72.0	86.0	74	36.5	G 1/8	XCM(G)T 17...TC/TA	XCMT 17R...GV
									D211-D212	D211

- ▶ OAL: LPR+LS
- ▶ Grooving insert is available for right handed type

Spare parts

Designation	Screw	Wrench	
TCAP 08	TS 18034I/HG-P	T 6P	-
TCAP 10	TS 20038I/HG-P	T 6P	-
TCAP 12	TS 22052I/HG-P	T 7P	-
TCAP 14	TS 25064I/HG-P	T 8P	-
TCAP 16	TS 30100I/HG-P	-	TD 9P
TCAP 20	TS 35088I/HG-P	-	TD10P
TCAP 25	TS 45A100I/HG	-	TD 20
TCAP 32	TS 45A100I/HG	-	TD 20



TCAP...-3.0DN



Multi-function toolholders - 3.0xD



• Internal coolant

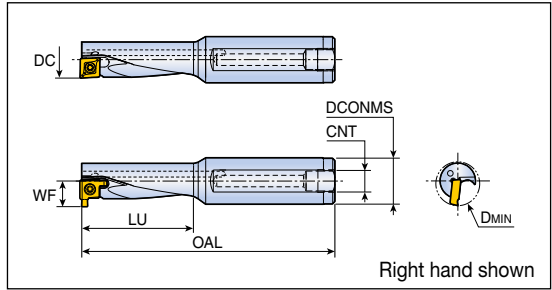
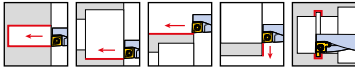

Designation	Dimension (mm)							Insert	
	DC	DCONMS	WF	LU	OAL	DMIN	CNT	For drilling, boring, turning	For grooving
TCAP 08R/L-3.0DN12	8	12	-	24	80	-	G 1/16	XCM(G)T 04...TC/TA	-
10R/L-3.0DN-GV	10	12	7.1	30	85	12.0	G 1/16	XCM(G)T 05...TC/TA	XCMT 05R...GV
12R/L-3.0DN-GV	12	16	8.5	36	95	14.5	G 1/8	XCM(G)T 06...TC/TA	XCMT 06R...GV
14R/L-3.0DN-GV	14	16	9.5	42	100	16.5	G 1/8	XCM(G)T 07...TC/TA	XCMT 07R...GV
16R/L-3.0DN-GV	16	20	11.1	48	110	19.0	G 1/8	XCM(G)T 08...TC/TA	XCMT 08R...GV
20R/L-3.0DN-GV	20	25	13.2	60	130	23.5	G 1/8	XCM(G)T 10...TC/TA	XCMT 10R...GV
25R/L-3.0DN-GV	25	32	16.5	75	150	29.0	G 1/8	XCM(G)T 13...TC/TA	XCMT 13R...GV
32R/L-3.0DN-GV	32	40	20.5	96	185	36.5	G 1/8	XCM(G)T 17...TC/TA	XCMT 17R...GV
								D211-D212	D211

- ▶ OA: LPR+LS
- ▶ Grooving insert is available for right handed type

Spare parts

Designation	Screw	Wrench	
TCAP 08	TS 18034I/HG-P	T 6P	-
TCAP 10	TS 20038I/HG-P	T 6P	-
TCAP 12	TS 22052I/HG-P	T 7P	-
TCAP 14	TS 25064I/HG-P	T 8P	-
TCAP 16	TS 30100I/HG-P	-	TD 9P
TCAP 20	TS 35088I/HG-P	-	TD10P
TCAP 25	TS 45A100I/HG	-	TD 20
TCAP 32	TS 45A100I/HG	-	TD 20



S...SXUCR/L



Boring bars with TOP-CAP inserts



- For boring
- External coolant

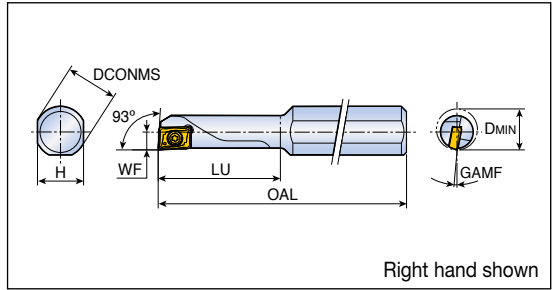
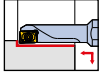

Designation	Dimension (mm)							Insert
	DCONMS	H	OAL	LU	WF	DMIN	GAMF	
S10H SXUCR/L 04-06 ⁽¹⁾	10	9	100	21	3.0	6	9°	XCMT 04...R/L TC
S10J SXUCR/L 04-07 ⁽¹⁾	10	9	110	24.5	3.5	7	5°	D212
S10K SXUCR/L 04-08 ⁽¹⁾	10	9	110	28	4.0	8	2°	
S10L SXUCR/L 05-10	10	9	125	35	5.0	10	2°	XCMT 05...TC
								D212

▶ ⁽¹⁾ Right hand Insert should be used in right hand boring bar

Spare parts

Designation	Screw	Wrench		
S10H SXUCR/L 04-06	TS 18034I/HG-P	T 6P		
S10J SXUCR/L 04-07	TS 18034I/HG-P	T 6P		
S10K SXUCR/L 04-08	TS 18034I/HG-P	T 6P		
S10L SXUCR/L 05-10	TS 20038I/HG-P	T 6P		



Sleeves for clamping unit

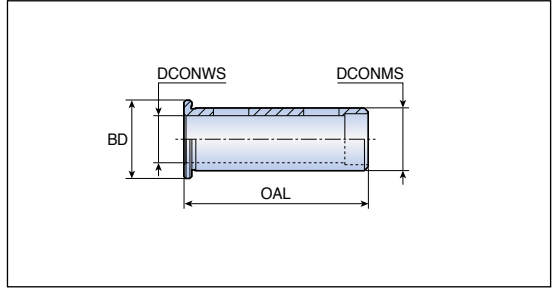

Designation	Dimension (mm)				Toolholders
	DCONMS	DCONWS	BD	OAL	
TSL 16-12	16	12	20	47	TCAP 10R/L...
25-20	25	20	32	55	TCAP 16R/L...

TBSL

Sleeves for boring bar

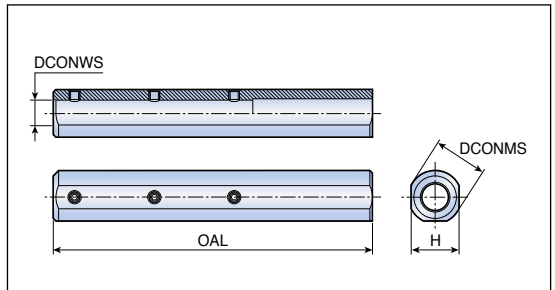

Designation	Dimension (mm)			
	DCONMS	DCONWS	OAL	H
TBSL 20-10-120	20	10	120	18

Spare parts

Designation	Screw	Wrench		
TBSL 20-10-120	SS M4x0.7x4	L-W 2		

3ED...T...-3D

Head changeable 3 flute drill holder

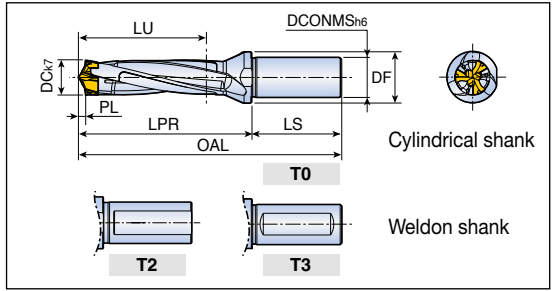

- Drilling depth: 3x diameter



Designation	Dimension (mm)								Clamping key
	DC	DCONMS	DF	LU	LPR	LS	PL	SSC	
3ED 120-124-16T3/T0-3D	12.0-12.4	16	20	40.0	60.7	48	2.74	12	K 3ED D12-D13
125-129-16T3/T0-3D	12.5-12.9	16	20	41.5	62.5	48	2.76	12	
130-134-16T3/T0-3D	13.0-13.4	16	20	43.0	64.8	48	2.91	13	
135-139-16T3/T0-3D	13.5-13.9	16	20	44.5	66.6	48	2.93	13	K 3ED D14-D15
140-144-16T3/T0-3D	14.0-14.4	16	20	46.0	68.9	48	3.17	14	
145-149-16T3/T0-3D	14.5-14.9	16	20	47.5	70.7	48	3.19	14	
150-159-20T3/T0-3D	15.0-15.9	20	25	49.0	73.9	50	3.31	15	K 3ED D16-D17
160-169-20T3/T0-3D	16.0-16.9	20	25	52.0	79.0	50	3.70	16	
170-179-20T3/T0-3D	17.0-17.9	20	25	55.0	84.0	50	3.88	17	
180-189-25T2/T0-3D	18.0-18.9	25	32	58.0	90.1	56	4.07	18	K 3ED D18-D19
190-199-25T2/T0-3D	19.0-19.9	25	32	61.0	94.7	56	4.26	19	
200-209-25T2/T0-3D	20.0-20.9	25	32	64.0	99.3	56	4.44	20	
210-219-25T2/T0-3D	21.0-21.9	25	32	67.0	103.8	56	4.62	21	K 3ED D20-D21
220-229-25T2/T0-3D	22.0-22.9	25	32	70.0	108.4	56	4.78	22	
230-239-32T2/T0-3D	23.0-23.9	32	42	73.0	112.8	60	5.02	23	
240-249-32T2/T0-3D	24.0-24.9	32	42	76.0	117.4	60	5.18	24	K 3ED D22-D23
250-259-32T2/T0-3D	25.0-25.9	32	42	79.0	122.0	60	5.29	25	



- ▶ OAL: LPR+LS
- ▶ SSC: Seat size code

3ED...T...-5D



Head changeable 3 flute drill holder



• Drilling depth: 5x diameter

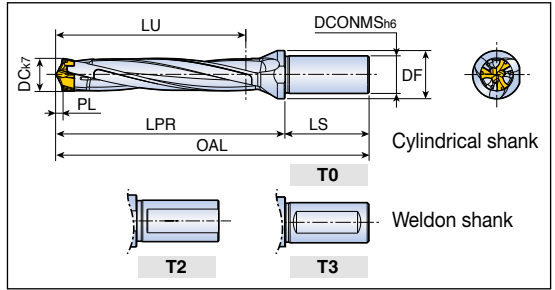

Designation	Dimension (mm)								Clamping key
	DC	DCONMS	DF	LU	LPR	LS	PL	SSC	
3ED 120-124-16T3/T0-5D	12.0-12.4	16	20	64.0	84.7	48	2.74	12	K 3ED D12-D13
125-129-16T3/T0-5D	12.5-12.9	16	20	66.5	87.5	48	2.76	12	
130-134-16T3/T0-5D	13.0-13.4	16	20	69.0	90.8	48	2.91	13	
135-139-16T3/T0-5D	13.5-13.9	16	20	71.5	93.6	48	2.93	13	K 3ED D14-D15
140-144-16T3/T0-5D	14.0-14.4	16	20	74.0	96.9	48	3.17	14	
145-149-16T3/T0-5D	14.5-14.9	16	20	76.5	99.7	48	3.19	14	
150-159-20T3/T0-5D	15.0-15.9	20	25	79.0	103.9	50	3.31	15	K 3ED D16-D17
160-169-20T3/T0-5D	16.0-16.9	20	25	84.0	111.0	50	3.70	16	
170-179-20T3/T0-5D	17.0-17.9	20	25	89.0	118.0	50	3.88	17	
180-189-25T2/T0-5D	18.0-18.9	25	32	94.0	126.1	56	4.07	18	K 3ED D18-D19
190-199-25T2/T0-5D	19.0-19.9	25	32	99.0	132.7	56	4.26	19	K 3ED D20-D21
200-209-25T2/T0-5D	20.0-20.9	25	32	104.0	139.3	56	4.44	20	
210-219-25T2/T0-5D	21.0-21.9	25	32	109.0	145.8	56	4.62	21	
220-229-25T2/T0-5D	22.0-22.9	25	32	114.0	152.4	56	4.78	22	K 3ED D22-D23
230-239-32T2/T0-5D	23.0-23.9	32	42	119.0	158.8	60	5.02	23	K 3ED D24-D25
240-249-32T2/T0-5D	24.0-24.9	32	42	124.0	165.4	60	5.18	24	
250-259-32T2/T0-5D	25.0-25.9	32	42	129.0	172.0	60	5.29	25	

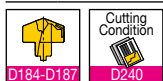

▶ OAL: LPR+LS
▶ SSC: Seat size code

3ED...T...-8D



Head changeable 3 flute drill holder



- Drilling depth: 8x diameter

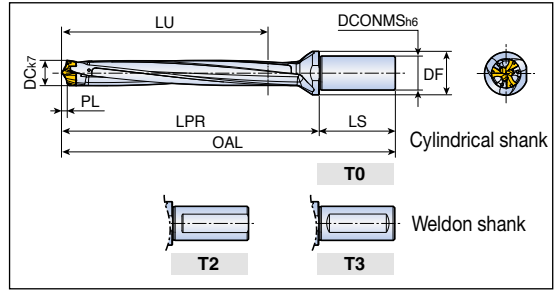

Designation	Dimension (mm)								Clamping key
	DC	DCONMS	DF	LU	LPR	LS	PL	SSC	
3ED 120-124-16T3/T0-8D	12.0-12.4	16	20	100	120.7	48	2.74	12	K 3ED D12-D13
125-129-16T3/T0-8D	12.5-12.9	16	20	104	125.0	48	2.76	12	
130-134-16T3/T0-8D	13.0-13.4	16	20	108	129.8	48	2.91	13	
135-139-16T3/T0-8D	13.5-13.9	16	20	112	134.1	48	2.93	13	K 3ED D14-D15
140-144-16T3/T0-8D	14.0-14.4	16	20	116	138.9	48	3.17	14	
145-149-16T3/T0-8D	14.5-14.9	16	20	120	143.2	48	3.19	14	
150-159-20T3/T0-8D	15.0-15.9	20	25	124	148.9	50	3.31	15	K 3ED D16-D17
160-169-20T3/T0-8D	16.0-16.9	20	25	132	159.0	50	3.70	16	
170-179-20T3/T0-8D	17.0-17.9	20	25	140	169.0	50	3.88	17	
180-189-25T2/T0-8D	18.0-18.9	25	32	148	180.1	56	4.07	18	K 3ED D18-D19
190-199-25T2/T0-8D	19.0-19.9	25	32	156	189.7	56	4.26	19	
200-209-25T2/T0-8D	20.0-20.9	25	32	164	199.3	56	4.44	20	
210-219-25T2/T0-8D	21.0-21.9	25	32	172	208.8	56	4.62	21	K 3ED D20-D21
220-229-25T2/T0-8D	22.0-22.9	25	32	180	218.4	56	4.78	22	
230-239-32T2/T0-8D	23.0-23.9	32	42	188	227.8	60	5.02	23	
240-249-32T2/T0-8D	24.0-24.9	32	42	196	237.4	60	5.18	24	K 3ED D22-D23
250-259-32T2/T0-8D	25.0-25.9	32	42	204	247.0	60	5.29	25	
									K 3ED D24-D25



- ▶ OAL: LPR+LS
- ▶ SSC: Seat size code

TCD...-3D



Head changeable drill holders - Cylindrical type shank



- Drilling depth: 3xdiameter

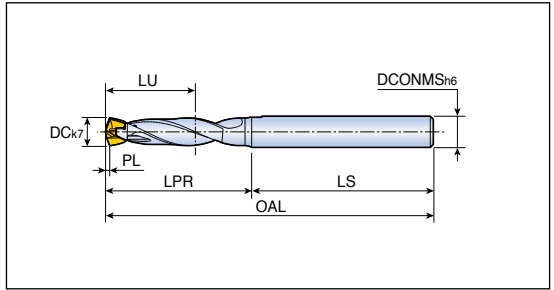

Designation	Dimension (mm)							Clamping key
	DC	DCONMS	LU	LPR	LS	PL	SSC	
TCD 040-044-06A0-3D	4.0-4.4	6	13	22.7	35	0.62	4	K TCD D040-D049
045-049-06A0-3D	4.5-4.9	6	14	24.7	35	0.66	4.5	
050-054-06A0-3D	5.0-5.4	6	16	26.3	35	0.73	5	K TCD D050-D059
055-059-06A0-3D	5.5-5.9	6	17	28.2	35	0.81	5.5	



- ▶ OAL: LPR+LS
- ▶ SSC: Seat size code

TCD...-5D



Head changeable drill holders - Cylindrical type shank



- Drilling depth: 5xdiameter

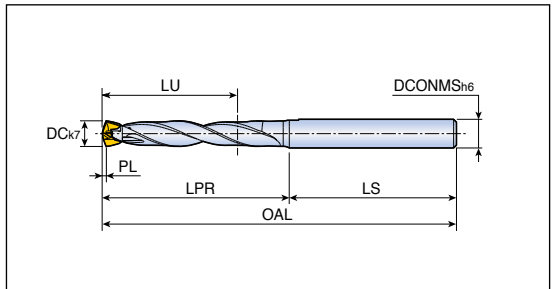

Designation	Dimension (mm)							Clamping key
	DC	DCONMS	LU	LPR	LS	PL	SSC	
TCD 040-044-06A0-5D	4.0-4.4	6	21	30.7	35	0.62	4	K TCD D040-D049
045-049-06A0-5D	4.5-4.9	6	23	33.7	35	0.66	4.5	
050-054-06A0-5D	5.0-5.4	6	26	36.3	35	0.73	5	K TCD D050-D059
055-059-06A0-5D	5.5-5.9	6	28	39.2	35	0.81	5.5	



- ▶ OAL: LPR+LS
- ▶ SSC: Seat size code

TCD...T...-1.5D



Head changeable drill holders - Weldon type shank



- Drilling depth: 1.5x diameter

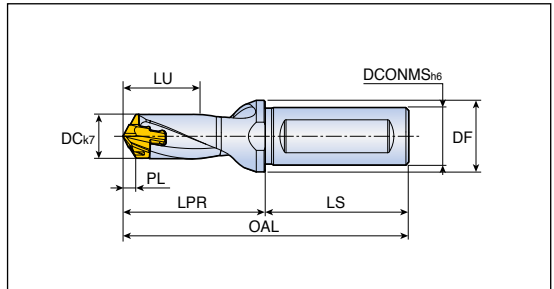

Designation	Dimension (mm)								Clamping key	
	DC	DCONMS	DF	LU	LPR	LS	PL	SSC		
TCD 060-064-12T3-1.5D	6.0-6.4	12	16	10	23.0	45	0.96	6	K TCD D060-D099	
065-069-12T3-1.5D	6.5-6.9	12	16	11	24.1	45	1.18	6.5		
070-074-12T3-1.5D	7.0-7.4	12	16	12	25.1	45	1.01	7		
075-079-12T3-1.5D	7.5-7.9	12	16	12	25.9	45	1.10	7		
080-089-12T3-1.5D	8.0-8.9	12	16	13	27.4	45	1.20	8		
090-099-12T3-1.5D	9.0-9.9	12	16	15	29.3	45	1.35	9		
100-109-16T3-1.5D	10.0-10.9	16	20	17	31.2	48	1.50	10		K TCD D100-D199
110-119-16T3-1.5D	11.0-11.9	16	20	19	33.1	48	1.67	11		
120-129-16T3-1.5D	12.0-12.9	16	20	20	35.0	48	1.82	12		
130-139-16T3-1.5D	13.0-13.9	16	20	22	37.1	48	1.96	13		
140-149-16T3-1.5D	14.0-14.9	16	20	23	41.1	48	2.12	14		
150-159-20T3-1.5D	15.0-15.9	20	25	25	46.2	50	2.27	15		
160-169-20T3-1.5D	16.0-16.9	20	25	26	49.3	50	2.42	16		
170-179-20T3-1.5D	17.0-17.9	20	25	29	52.4	50	2.59	17		
180-189-25T2-1.5D	18.0-18.9	25	32	30	55.5	56	2.73	18		
190-199-25T2-1.5D	19.0-19.9	25	32	32	58.5	56	2.88	19	K TCD D200-D269	
200-209-25T2-1.5D	20.0-20.9	25	32	33	61.6	56	3.02	20		
210-219-25T2-1.5D	21.0-21.9	25	32	35	64.7	56	3.18	21		
220-229-25T2-1.5D	22.0-22.9	25	32	36	67.8	56	3.24	22		
230-239-32T2-1.5D	23.0-23.9	32	42	38	70.8	60	3.46	23		
240-249-32T2-1.5D	24.0-24.9	32	42	40	73.9	60	3.62	24		
250-259-32T2-1.5D	25.0-25.9	32	42	42	77.0	60	3.80	25		

D189-D202

Sleeve
D109

Cutting Condition
D242

- ▶ OAL: LPR+LS
- ▶ SSC: Seat size code

TCD...S0-1.5D



Head changeable drill holders - Cylindrical type shank



• Drilling depth: 1.5x diameter

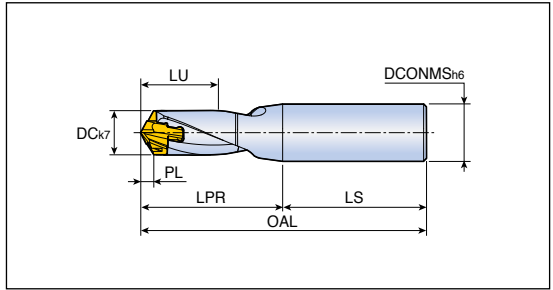

Designation	Dimension (mm)							Clamping key
	DC	DCONMS	LU	LPR	LS	PL	SSC	
TCD 060-064-12S0-1.5D	6.0-6.4	12	10	23.0	45	0.96	6	K TCD D060-D099
065-069-12S0-1.5D	6.5-6.9	12	11	24.1	45	1.18	6.5	
070-074-12S0-1.5D	7.0-7.4	12	12	25.1	45	1.01	7	
075-079-12S0-1.5D	7.5-7.9	12	12	25.9	45	1.10	7	
080-089-12S0-1.5D	8.0-8.9	12	13	27.4	45	1.20	8	
090-099-12S0-1.5D	9.0-9.9	12	15	29.3	45	1.35	9	
100-109-16S0-1.5D	10.0-10.9	16	17	31.2	48	1.50	10	K TCD D100-D199
110-119-16S0-1.5D	11.0-11.9	16	19	33.1	48	1.67	11	
120-129-16S0-1.5D	12.0-12.9	16	20	35.0	48	1.82	12	
130-139-16S0-1.5D	13.0-13.9	16	22	37.1	48	1.96	13	
140-149-16S0-1.5D	14.0-14.9	16	23	41.1	48	2.12	14	
150-159-20S0-1.5D	15.0-15.9	20	25	46.2	50	2.27	15	
160-169-20S0-1.5D	16.0-16.9	20	26	49.3	50	2.42	16	K TCD D200-D269
170-179-20S0-1.5D	17.0-17.9	20	29	52.4	50	2.59	17	
180-189-25S0-1.5D	18.0-18.9	25	30	55.5	56	2.73	18	
190-199-25S0-1.5D	19.0-19.9	25	32	58.5	56	2.88	19	
200-209-25S0-1.5D	20.0-20.9	25	33	61.6	56	3.02	20	
210-219-25S0-1.5D	21.0-21.9	25	35	64.7	56	3.18	21	
220-229-25S0-1.5D	22.0-22.9	25	36	67.8	56	3.24	22	
230-239-32S0-1.5D	23.0-23.9	32	38	70.8	60	3.46	23	
240-249-32S0-1.5D	24.0-24.9	32	40	73.9	60	3.62	24	
250-259-32S0-1.5D	25.0-25.9	32	42	77.0	60	3.80	25	

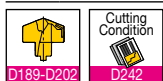

▶ OAL: LPR+LS
▶ SSC: Seat size code

Head changeable drill holders - Weldon type shank



- Drilling depth: 3xdiameter

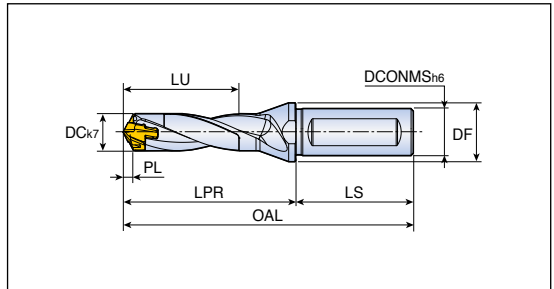

Designation	Dimension (mm)								Clamping key	
	DC	DCONMS	DF	LU	LPR	LS	PL	SSC		
TCD 060-064-12T3-3D	6.0-6.4	12	16	19	32.0	45	0.96	6	K TCD D060-D099	
065-069-12T3-3D	6.5-6.9	12	16	21	33.8	45	1.18	6.5		
070-074-12T3-3D	7.0-7.4	12	16	22	35.6	45	1.01	7		
075-079-12T3-3D	7.5-7.9	12	16	24	37.1	45	1.10	7		
080-084-12T3-3D	8.0-8.4	12	16	25	39.4	45	1.20	8		
085-089-12T3-3D	8.5-8.9	12	16	27	40.9	45	1.29	8		
090-094-12T3-3D	9.0-9.4	12	16	28	42.8	45	1.35	9		
095-099-12T3-3D	9.5-9.9	12	16	30	44.3	45	1.44	9		
100-104-16T3-3D	10.0-10.4	16	20	32	46.2	48	1.50	10		K TCD D100-D199
105-109-16T3-3D	10.5-10.9	16	20	34	47.7	48	1.59	10		
110-114-16T3-3D	11.0-11.4	16	20	35	49.6	48	1.67	11		
115-119-16T3-3D	11.5-11.9	16	20	37	51.1	48	1.76	11		
120-124-16T3-3D	12.0-12.4	16	20	38	53.0	48	1.82	12		
125-129-16T3-3D	12.5-12.9	16	20	39	54.5	48	1.91	12		
130-134-16T3-3D	13.0-13.4	16	20	41	56.6	48	1.96	13		
135-139-16T3-3D	13.5-13.9	16	20	43	58.1	48	2.05	13		
140-144-16T3-3D	14.0-14.4	16	20	44	62.2	48	2.12	14		
145-149-16T3-3D	14.5-14.9	16	20	46	63.7	48	2.21	14		
150-159-20T3-3D	15.0-15.9	20	25	47	68.7	50	2.27	15	K TCD D200-D269	
160-169-20T3-3D	16.0-16.9	20	25	50	73.3	50	2.42	16		
170-179-20T3-3D	17.0-17.9	20	25	54	77.9	50	2.59	17		
180-189-25T2-3D	18.0-18.9	25	32	57	82.5	56	2.73	18		
190-199-25T2-3D	19.0-19.9	25	32	60	87.0	56	2.88	19		
200-209-25T2-3D	20.0-20.9	25	32	63	91.6	56	3.02	20		
210-219-25T2-3D	21.0-21.9	25	32	66	96.2	56	3.18	21		
220-229-25T2-3D	22.0-22.9	25	32	69	100.8	56	3.24	22		
230-239-32T2-3D	23.0-23.9	32	42	72	105.3	60	3.46	23		
240-249-32T2-3D	24.0-24.9	32	42	76	109.9	60	3.62	24		
250-259-32T2-3D	25.0-25.9	32	42	79	114.5	60	3.80	25		

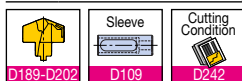

- ▶ OAL: LPR+LS
- ▶ SSC: Seat size code

TCD...S0-3D

Head changeable drill holders - Cylindrical type shank



- Drilling depth: 3x diameter

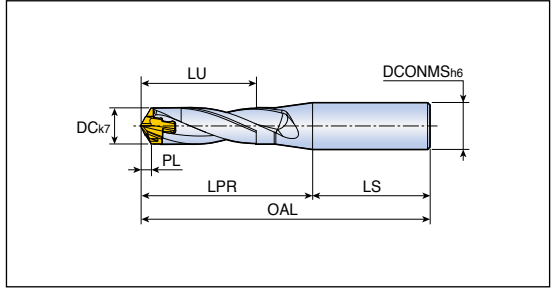

Designation	Dimension (mm)							Clamping key	
	DC	DCONMS	LU	LPR	LS	PL	SSC		
TCD 060-064-12S0-3D	6.0-6.4	12	19	32.0	45	0.96	6	K TCD D060-D099	
065-069-12S0-3D	6.5-6.9	12	21	33.8	45	1.18	6.5		
070-074-12S0-3D	7.0-7.4	12	22	35.6	45	1.01	7		
075-079-12S0-3D	7.5-7.9	12	24	37.1	45	1.10	7		
080-084-12S0-3D	8.0-8.4	12	25	39.4	45	1.20	8		
085-089-12S0-3D	8.5-8.9	12	27	40.9	45	1.29	8		
090-094-12S0-3D	9.0-9.4	12	28	42.8	45	1.35	9		
095-099-12S0-3D	9.5-9.9	12	30	44.3	45	1.44	9		
100-104-16S0-3D	10.0-10.4	16	32	46.2	48	1.50	10		K TCD D100-D199
105-109-16S0-3D	10.5-10.9	16	34	47.7	48	1.59	10		
110-114-16S0-3D	11.0-11.4	16	35	49.6	48	1.67	11		
115-119-16S0-3D	11.5-11.9	16	37	51.1	48	1.76	11		
120-124-16S0-3D	12.0-12.4	16	38	53.0	48	1.82	12		
125-129-16S0-3D	12.5-12.9	16	39	54.5	48	1.91	12		
130-134-16S0-3D	13.0-13.4	16	41	56.6	48	1.96	13		
135-139-16S0-3D	13.5-13.9	16	43	58.1	48	2.05	13		
140-144-16S0-3D	14.0-14.4	16	44	62.1	48	2.12	14		
145-149-16S0-3D	14.5-14.9	16	46	63.7	48	2.21	14		
150-159-20S0-3D	15.0-15.9	20	47	68.7	50	2.27	15	K TCD D200-D269	
160-169-20S0-3D	16.0-16.9	20	50	73.3	50	2.42	16		
170-179-20S0-3D	17.0-17.9	20	54	77.9	50	2.59	17		
180-189-25S0-3D	18.0-18.9	25	57	82.5	56	2.73	18		
190-199-25S0-3D	19.0-19.9	25	60	87.0	56	2.88	19		
200-209-25S0-3D	20.0-20.9	25	63	91.6	56	3.02	20		
210-219-25S0-3D	21.0-21.9	25	66	96.2	56	3.18	21		
220-229-25S0-3D	22.0-22.9	25	69	100.8	56	3.24	22		
230-239-32S0-3D	23.0-23.9	32	72	105.3	60	3.46	23		
240-249-32S0-3D	24.0-24.9	32	76	109.9	60	3.62	24		
250-259-32S0-3D	25.0-25.9	32	79	114.5	60	3.80	25		

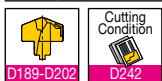

- ▶ OAL: LPR+LS
- ▶ SSC: Seat size code

Head changeable drill holders - Weldon type shank



- Drilling depth: 5xdiameter

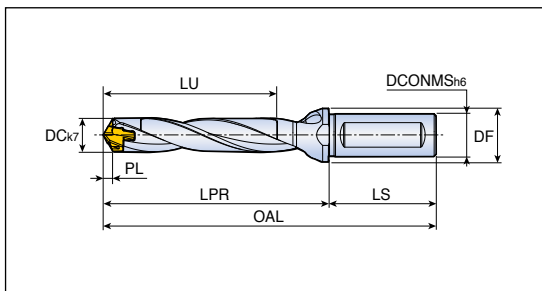

Designation	Dimension (mm)								Clamping key	
	DC	DCONMS	DF	LU	LPR	LS	PL	SSC		
TCD 060-064-12T3-5D	6.0-6.4	12	16	31	44.0	45	0.96	6	K TCD D060-D099	
065-069-12T3-5D	6.5-6.9	12	16	34	46.8	45	1.18	6.5		
070-074-12T3-5D	7.0-7.4	12	16	36	49.6	45	1.01	7		
075-079-12T3-5D	7.5-7.9	12	16	39	52.1	45	1.10	7		
080-084-12T3-5D	8.0-8.4	12	16	41	55.4	45	1.20	8		
085-089-12T3-5D	8.5-8.9	12	16	44	57.9	45	1.29	8		
090-094-12T3-5D	9.0-9.4	12	16	46	60.8	45	1.35	9		
095-099-12T3-5D	9.5-9.9	12	16	49	63.3	45	1.44	9		
100-104-16T3-5D	10.0-10.4	16	20	52	66.2	48	1.50	10		K TCD D100-D199
105-109-16T3-5D	10.5-10.9	16	20	55	68.7	48	1.59	10		
110-114-16T3-5D	11.0-11.4	16	20	57	71.6	48	1.67	11		
115-119-16T3-5D	11.5-11.9	16	20	60	74.1	48	1.76	11		
120-124-16T3-5D	12.0-12.4	16	20	62	77.0	48	1.82	12		
125-129-16T3-5D	12.5-12.9	16	20	64	79.5	48	1.91	12		
130-134-16T3-5D	13.0-13.4	16	20	67	82.6	48	1.96	13		
135-139-16T3-5D	13.5-13.9	16	20	70	85.1	48	2.05	13		
140-144-16T3-5D	14.0-14.4	16	20	72	90.2	48	2.12	14		
145-149-16T3-5D	14.5-14.9	16	20	75	92.7	48	2.21	14		
150-159-20T3-5D	15.0-15.9	20	25	77	98.7	50	2.27	15	K TCD D200-D269	
160-169-20T3-5D	16.0-16.9	20	25	82	105.3	50	2.42	16		
170-179-20T3-5D	17.0-17.9	20	25	88	111.9	50	2.59	17		
180-189-25T2-5D	18.0-18.9	25	32	93	118.5	56	2.73	18		
190-199-25T2-5D	19.0-19.9	25	32	98	125.0	56	2.88	19		
200-209-25T2-5D	20.0-20.9	25	32	103	131.6	56	3.02	20		
210-219-25T2-5D	21.0-21.9	25	32	108	138.2	56	3.18	21		
220-229-25T2-5D	22.0-22.9	25	32	113	144.8	56	3.24	22		
230-239-32T2-5D	23.0-23.9	32	42	118	151.3	60	3.46	23		
240-249-32T2-5D	24.0-24.9	32	42	124	157.9	60	3.62	24		
250-259-32T2-5D	25.0-25.9	32	42	129	164.5	60	3.80	25		

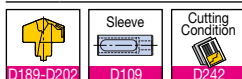

- ▶ OAL: LPR+LS
- ▶ SSC: Seat size code

TCD...S0-5D



Head changeable drill holders - Cylindrical type shank



- Drilling depth: 5x diameter

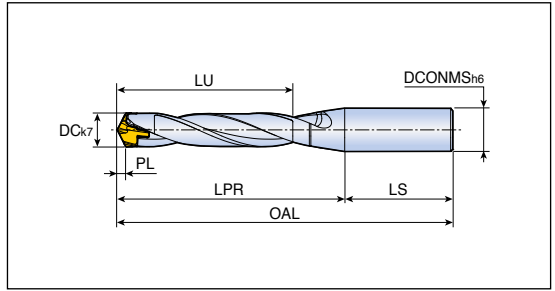

Designation	Dimension (mm)							Clamping key	
	DC	DCONMS	LU	LPR	LS	PL	SSC		
TCD 060-064-12S0-5D	6.0-6.4	12	31	44.0	45	0.96	6	K TCD D060-D099	
065-069-12S0-5D	6.5-6.9	12	34	46.8	45	1.18	6.5		
070-074-12S0-5D	7.0-7.4	12	36	49.6	45	1.01	7		
075-079-12S0-5D	7.5-7.9	12	39	52.1	45	1.10	7		
080-084-12S0-5D	8.0-8.4	12	41	55.4	45	1.20	8		
085-089-12S0-5D	8.5-8.9	12	44	57.9	45	1.29	8		
090-094-12S0-5D	9.0-9.4	12	46	60.8	45	1.35	9		
095-099-12S0-5D	9.5-9.9	12	49	63.3	45	1.44	9		
100-104-16S0-5D	10.0-10.4	16	52	66.2	48	1.50	10		K TCD D100-D199
105-109-16S0-5D	10.5-10.9	16	55	68.7	48	1.59	10		
110-114-16S0-5D	11.0-11.4	16	57	71.6	48	1.67	11		
115-119-16S0-5D	11.5-11.9	16	60	74.1	48	1.76	11		
120-124-16S0-5D	12.0-12.4	16	62	77.0	48	1.82	12		
125-129-16S0-5D	12.5-12.9	16	64	79.5	48	1.91	12		
130-134-16S0-5D	13.0-13.4	16	67	82.6	48	1.96	13		
135-139-16S0-5D	13.5-13.9	16	70	85.1	48	2.05	13		
140-144-16S0-5D	14.0-14.4	16	72	90.2	48	2.12	14		
145-149-16S0-5D	14.5-14.9	16	75	92.7	48	2.21	14		
150-159-20S0-5D	15.0-15.9	20	77	98.7	50	2.27	15	K TCD D200-D269	
160-169-20S0-5D	16.0-16.9	20	82	105.3	50	2.42	16		
170-179-20S0-5D	17.0-17.9	20	88	111.9	50	2.59	17		
180-189-25S0-5D	18.0-18.9	25	93	118.5	56	2.73	18		
190-199-25S0-5D	19.0-19.9	25	98	125.0	56	2.88	19		
200-209-25S0-5D	20.0-20.9	25	103	131.6	56	3.02	20		
210-219-25S0-5D	21.0-21.9	25	108	138.2	56	3.18	21		
220-229-25S0-5D	22.0-22.9	25	113	144.8	56	3.24	22		
230-239-32S0-5D	23.0-23.9	32	118	151.3	60	3.46	23		
240-249-32S0-5D	24.0-24.9	32	124	157.9	60	3.62	24		
250-259-32S0-5D	25.0-25.9	32	129	164.5	60	3.80	25		

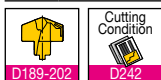

- ▶ OAL: LPR+LS
- ▶ SSC: Seat size code

TCD...T...-8D



Head changeable drill holders - Weldon type shank



- Drilling depth: 8xdiameter

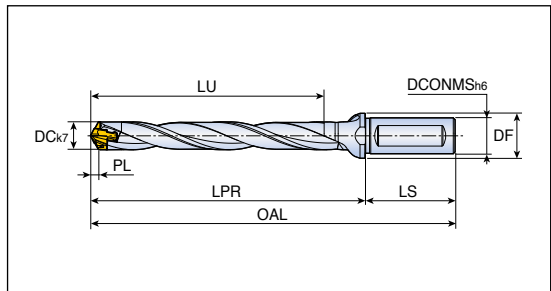

Designation	Dimension (mm)								Clamping key
	DC	DCONMS	DF	LU	LPR	LS	PL	SSC	
TCD 070-074-12T3-8D	7.0-7.4	12	16	57	70.6	45	1.01	7	K TCD D060-D099
075-079-12T3-8D	7.5-7.9	12	16	61	74.6	45	1.10	7	
080-084-12T3-8D	8.0-8.4	12	16	65	79.4	45	1.20	8	
085-089-12T3-8D	8.5-8.9	12	16	69	83.4	45	1.29	8	
090-094-12T3-8D	9.0-9.4	12	16	73	87.8	45	1.35	9	
095-099-12T3-8D	9.5-9.9	12	16	77	91.8	45	1.44	9	
100-104-16T3-8D	10.0-10.4	16	20	82	96.2	48	1.50	10	K TCD D100-D199
105-109-16T3-8D	10.5-10.9	16	20	86	100.2	48	1.59	10	
110-114-16T3-8D	11.0-11.4	16	20	90	104.6	48	1.67	11	
115-119-16T3-8D	11.5-11.9	16	20	94	108.6	48	1.76	11	
120-124-16T3-8D	12.0-12.4	16	20	98	113.0	48	1.82	12	
125-129-16T3-8D	12.5-12.9	16	20	102	117.0	48	1.91	12	
130-134-16T3-8D	13.0-13.4	16	20	106	121.6	48	1.96	13	
135-139-16T3-8D	13.5-13.9	16	20	110	125.6	48	2.05	13	
140-144-16T3-8D	14.0-14.4	16	20	114	132.2	48	2.12	14	
145-149-16T3-8D	14.5-14.9	16	20	118	136.2	48	2.21	14	
150-159-20T3-8D	15.0-15.9	20	25	122	143.7	50	2.27	15	K TCD D200-D269
160-169-20T3-8D	16.0-16.9	20	25	130	153.3	50	2.42	16	
170-179-20T3-8D	17.0-17.9	20	25	139	162.9	50	2.59	17	
180-189-25T2-8D	18.0-18.9	25	32	147	172.5	56	2.73	18	
190-199-25T2-8D	19.0-19.9	25	32	155	182.0	56	2.88	19	
200-209-25T2-8D	20.0-20.9	25	32	163	191.6	56	3.02	20	
210-219-25T2-8D	21.0-21.9	25	32	171	201.2	56	3.18	21	
220-229-25T2-8D	22.0-22.9	25	32	179	210.8	56	3.24	22	
230-239-32T2-8D	23.0-23.9	32	42	187	220.3	60	3.46	23	
240-249-32T2-8D	24.0-24.9	32	42	196	229.9	60	3.62	24	
250-259-32T2-8D	25.0-25.9	32	42	204	239.5	60	3.80	25	



- ▶ It is recommended to make the pilot hole with a 1.5D holder
- ▶ OAL: LPR+LS
- ▶ SSC: Seat size code

TCD...S0-8D



Head changeable drill holders - Cylindrical type shank



- Drilling depth: 8x diameter

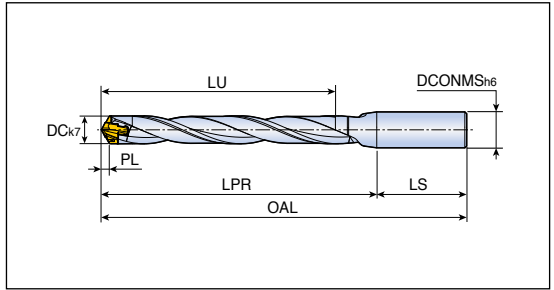

Designation	Dimension (mm)							Clamping key	
	DC	DCONMS	LU	LPR	LS	PL	SSC		
TCD 060-064-12S0-8D	6.0-6.4	12	49	62.0	45	0.96	6	K TCD D060-D099	
065-069-12S0-8D	6.5-6.9	12	53	66.3	45	1.18	6.5		
070-074-12S0-8D	7.0-7.4	12	57	70.6	45	1.01	7		
075-079-12S0-8D	7.5-7.9	12	61	74.6	45	1.10	7		
080-084-12S0-8D	8.0-8.4	12	65	79.4	45	1.20	8		
085-089-12S0-8D	8.5-8.9	12	69	83.4	45	1.29	8		
090-094-12S0-8D	9.0-9.4	12	73	87.8	45	1.35	9		
095-099-12S0-8D	9.5-9.9	12	77	91.8	45	1.44	9		
100-104-16S0-8D	10.0-10.4	16	82	96.2	48	1.50	10		K TCD D100-D199
105-109-16S0-8D	10.5-10.9	16	86	100.2	48	1.59	10		
110-114-16S0-8D	11.0-11.4	16	90	104.6	48	1.67	11		
115-119-16S0-8D	11.5-11.9	16	94	108.6	48	1.76	11		
120-124-16S0-8D	12.0-12.4	16	98	113.0	48	1.82	12		
125-129-16S0-8D	12.5-12.9	16	102	117.0	48	1.91	12		
130-134-16S0-8D	13.0-13.4	16	106	121.6	48	1.96	13		
135-139-16S0-8D	13.5-13.9	16	110	125.6	48	2.05	13		
140-144-16S0-8D	14.0-14.4	16	114	132.2	48	2.12	14		
145-149-16S0-8D	14.5-14.9	16	118	136.2	48	2.21	14		
150-159-20S0-8D	15.0-15.9	20	122	143.7	50	2.27	15	K TCD D200-D269	
160-169-20S0-8D	16.0-16.9	20	130	153.3	50	2.42	16		
170-179-20S0-8D	17.0-17.9	20	139	162.9	50	2.59	17		
180-189-25S0-8D	18.0-18.9	25	147	172.5	56	2.73	18		
190-199-25S0-8D	19.0-19.9	25	155	182.0	56	2.88	19		
200-209-25S0-8D	20.0-20.9	25	163	191.6	56	3.02	20		
210-219-25S0-8D	21.0-21.9	25	171	201.2	56	3.18	21		
220-229-25S0-8D	22.0-22.9	25	179	210.8	56	3.24	22		
230-239-32S0-8D	23.0-23.9	32	187	220.3	60	3.46	23		
240-249-32S0-8D	24.0-24.9	32	196	229.9	60	3.62	24		
250-259-32S0-8D	25.0-25.9	32	204	239.5	60	3.80	25		



- ▶ It is recommended to make the pilot hole with a 1.5D holder
- ▶ OAL: LPR+LS
- ▶ SSC: Seat size code

TCD...S0-12D



Head changeable drill holders - Cylindrical type shank

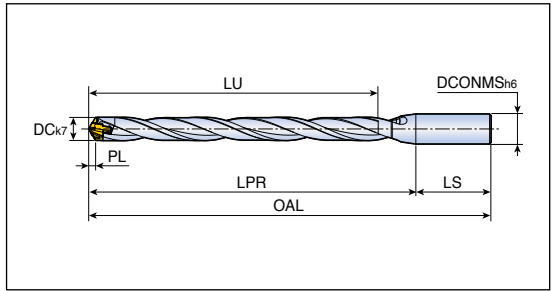

• Drilling depth: 12xdiameter



Designation	Dimension (mm)							Clamping key
	DC	DCONMS	LU	LPR	LS	PL	SSC	
TCD 080-084-12S0-12D	8.0-8.4	12	97	111.4	45	1.20	8	K TCD D060-D099
085-089-12S0-12D	8.5-8.9	12	103	117.4	45	1.29	8	
090-094-12S0-12D	9.0-9.4	12	109	123.8	45	1.35	9	
095-099-12S0-12D	9.5-9.9	12	115	129.8	45	1.44	9	
100-104-16S0-12D	10.0-10.4	16	122	136.2	48	1.50	10	
105-109-16S0-12D	10.5-10.9	16	128	142.2	48	1.59	10	
110-114-16S0-12D	11.0-11.4	16	134	148.6	48	1.67	11	
115-119-16S0-12D	11.5-11.9	16	140	154.6	48	1.76	11	
120-124-16S0-12D	12.0-12.4	16	146	161.0	48	1.82	12	
125-129-16S0-12D	12.5-12.9	16	152	167.0	48	1.91	12	
130-134-16S0-12D	13.0-13.4	16	158	173.6	48	1.96	13	
135-139-16S0-12D	13.5-13.9	16	164	179.6	48	2.05	13	
140-144-16S0-12D	14.0-14.4	16	170	188.2	48	2.12	14	
145-149-16S0-12D	14.5-14.9	16	176	194.2	48	2.21	14	
150-159-20S0-12D	15.0-15.9	20	182	203.7	50	2.27	15	K TCD D200-D269
160-169-20S0-12D	16.0-16.9	20	194	217.3	50	2.42	16	
170-179-20S0-12D	17.0-17.9	20	207	230.9	50	2.59	17	
180-189-25S0-12D	18.0-18.9	25	219	244.5	56	2.73	18	
190-199-25S0-12D	19.0-19.9	25	221	258.0	56	2.88	19	
200-209-25S0-12D	20.0-20.9	25	243	271.6	56	3.02	20	
210-219-25S0-12D	21.0-21.9	25	255	285.2	56	3.18	21	
220-229-25S0-12D	22.0-22.9	25	267	298.8	56	3.24	22	
230-239-32S0-12D	23.0-23.9	32	289	312.3	60	3.46	23	
240-249-32S0-12D	24.0-24.9	32	292	325.9	60	3.62	24	
250-259-32S0-12D	25.0-25.9	32	304	339.5	60	3.80	25	



- ▶ It is recommended to make the pilot hole with a 1.5D holder
- ▶ OAL: LPR+LS
- ▶ SSC: Seat size code

Head changeable drill holders for pre-thread hole

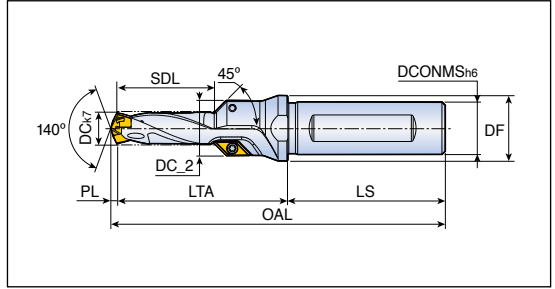

Designation	ISO thread	DC	Dimension (mm)							Drill dia. range	Insert
			SDL	LTA	LS	DC_2	DCONMS	DF	PL		
TCD 068x21x12T3-M8	M8	6.8	21	43.77	45	13.5	12	16	1.23	6.5-6.9	AOMT 06...-C45 D203
085x26x12T3-M10	M10	8.5	26	48.71	45	15.5	12	16	1.29	8.5-8.9	
102x30x16T3-M12	M12	10.2	30	52.46	48	17.0	16	20	1.54	10.0-10.4	
120x35x16T3-M14	M14	12.0	35	59.18	48	19.0	16	20	1.82	12.0-12.4	
140x39x20T3-M16	M16	14.0	39	66.88	50	21.0	20	25	2.12	14.0-14.4	
175x42x20T3-M20	M20	17.5	42	69.32	50	24.5	20	27	2.68	17.0-17.9	
210x48x25T2-M24	M24	21.0	48	76.82	56	28.0	25	32	3.18	21.0-21.9	

▶ OAL: LTA+LS+PL

Spare parts

Designation	Screw	Wrench	Clamping key	
TCD 068	TS 22046I	TD 7	K TCD D060-D099	
TCD 085	TS 22046I	TD 7	K TCD D060-D099	
TCD 102 - 175	TS 22046I	TD 7	K TCD D100-D199	
TCD 210	TS 22046I	TD 7	K TCD D200-D269	



Plug for coolant supply in a stationary machines

TaeguTec supplies special plugs with an internal thread for coolant connections used on lathes that can be pressed into the cavity on the back end of the shank.

Description	Shank diameter	Internal thread
PL-TCD-12	12	G 1/16
PL-TCD-16	16	G 1/16
PL-TCD-20	20	G 1/8
PL-TCD-25	25	G 1/8
PL-TCD-32	32	G 1/8



Chamfering ring tools

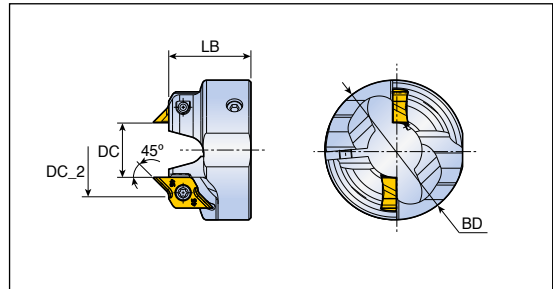

Designation	Dimension (mm)				Chamfer size	Chamfer insert
	DC	DC_2	BD	LB		
CFR D100-A45	9.8	16.56	34	20	2.5	CRNG 08...-45CD D203
D105-A45	10.3	17.06	34	20	2.5	
D110-A45	10.8	17.56	34	20	2.5	
D115-A45	11.3	18.06	34	20	2.5	
D120-A45	11.8	18.56	34	20	2.5	
D125-A45	12.3	19.06	34	20	2.5	
D130-A45	12.8	19.56	34	20	2.5	
D135-A45	13.3	20.06	34	20	2.5	
D140-A45	13.8	20.56	38	22	2.5	
D145-A45	14.3	21.06	38	22	2.5	
D150-A45	14.6	21.36	38	22	2.5	
D160-A45	15.6	22.36	42	23	2.5	
D170-A45	16.6	23.36	42	23	2.5	
D180-A45	17.6	24.36	42	23	2.5	
D190-A45	18.6	25.36	42	24	2.5	
D200-A45	19.6	26.36	42	24	2.5	
D210-A45	20.6	27.36	47	24	2.5	
D220-A45	21.6	28.36	47	24	2.5	
D230-A45	22.6	29.36	47	24	2.5	
D240-A45	23.6	30.36	47	24	2.5	
D250-A45	24.6	31.36	47	24	2.5	

Spare parts

Designation	Insert screw 	Wrench 	Clamping screw 	L-wrench
CFR D100 - D135	SO 250651	TD 7	SH M3x0.5x10 ⁽¹⁾	L-W2.5
CFR D140 - D150	SO 250651	TD 7	SH M4x0.7x12 ⁽²⁾	L-W3
CFR D160 - D250	SO 250651	TD 7	SH M5x0.8x16 ⁽³⁾	L-W4



► ⁽¹⁾ Clamping torque: 2-3 [N*m] ⁽²⁾ Clamping torque: 3.5-4.5 [N*m] ⁽³⁾ Clamping torque: 5-6 [N*m]

TCD...A0-3D/5D/8D



Head changeable drill holders - Cylindrical type shank



- Drilling depth: 3/5/8xdiameter

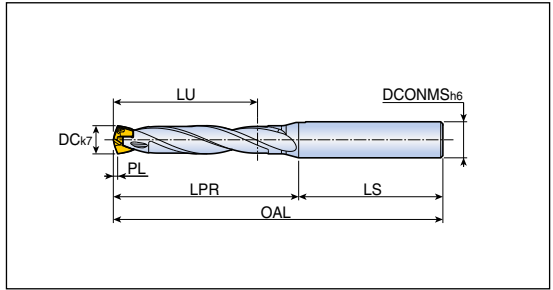

Designation	Dimension (mm)							Clamping key
	DC	DCONMS	LU	LPR	LS	PL	SSC	
TCD 060-064-08A0-3D	6.0-6.4	8	19	28.0	36	0.96	6	K TCD D060-D099
065-069-08A0-3D	6.5-6.9	8	21	29.8	36	1.18	6.5	
070-074-08A0-3D	7.0-7.4	8	22	31.6	36	1.01	7	
075-079-08A0-3D	7.5-7.9	8	24	33.1	36	1.10	7.5	
080-084-10A0-3D	8.0-8.4	10	25	35.4	40	1.20	8	
085-089-10A0-3D	8.5-8.9	10	27	36.9	40	1.29	8.5	
090-094-10A0-3D	9.0-9.4	10	28	38.8	40	1.35	9	
095-099-10A0-3D	9.5-9.9	10	30	40.3	40	1.44	9.5	
TCD 060-064-08A0-5D	6.0-6.4	8	31	40.0	36	0.96	6	
065-069-08A0-5D	6.5-6.9	8	34	42.8	36	1.18	6.5	
070-074-08A0-5D	7.0-7.4	8	36	45.6	36	1.01	7	
075-079-08A0-5D	7.5-7.9	8	39	48.1	36	1.10	7.5	
080-084-10A0-5D	8.0-8.4	10	41	51.4	40	1.20	8	
085-089-10A0-5D	8.5-8.9	10	44	53.9	40	1.29	8.5	
090-094-10A0-5D	9.0-9.4	10	46	56.8	40	1.35	9	
095-099-10A0-5D	9.5-9.9	10	49	59.3	40	1.44	9.5	
TCD 060-064-08A0-8D	6.0-6.4	8	49	58.0	36	0.96	6	K TCD D060-D099
065-069-08A0-8D	6.5-6.9	8	53	62.3	36	1.18	6.5	
070-074-08A0-8D	7.0-7.4	8	57	66.6	36	1.01	7	
075-079-08A0-8D	7.5-7.9	8	61	70.6	36	1.10	7.5	
080-084-10A0-8D	8.0-8.4	10	65	75.4	40	1.20	8	
085-089-10A0-8D	8.5-8.9	10	69	79.4	40	1.29	8.5	
090-094-10A0-8D	9.0-9.4	10	73	83.8	40	1.35	9	
095-099-10A0-8D	9.5-9.9	10	77	87.8	40	1.44	9.5	

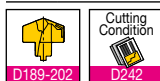

- ▶ OAL: LPR+LS
- ▶ SSC: Seat size code

TCDM...-M12-2D



Head changeable drill holder with T-FLEXTEC type shank



• Drilling depth: 2xdiameter

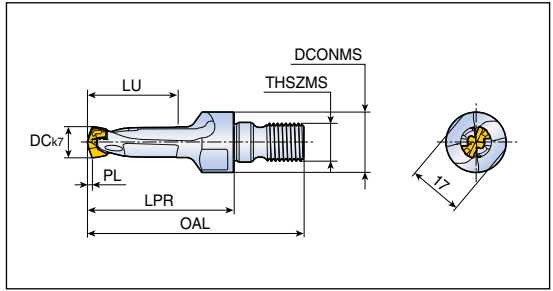

Designation	Dimension (mm)								Clamping key
	DC	DCONMS	LU	LPR	PL	OAL	THSZMS	SSC	
TCDM 100-104-M12-2D	10.0-10.4	19	28.7	46.2	1.5	68.2	M12	10	K TCD D100-D199
105-109-M12-2D	10.5-10.9	19	29.7	47.2	1.6	69.2	M12	10	
110-114-M12-2D	11.0-11.4	19	31.1	48.6	1.7	70.6	M12	11	
115-119-M12-2D	11.5-11.9	19	32.1	49.6	1.8	71.6	M12	11	
120-124-M12-2D	12.0-12.4	19	33.5	51.0	1.8	73.0	M12	12	
125-129-M12-2D	12.5-12.9	19	34.5	52.0	1.9	74.0	M12	12	
130-134-M12-2D	13.0-13.4	19	36.1	53.6	2.0	75.6	M12	13	
135-139-M12-2D	13.5-13.9	19	37.1	54.6	2.1	76.6	M12	13	
140-144-M12-2D	14.0-14.4	19	38.7	56.2	2.1	78.2	M12	14	
145-149-M12-2D	14.5-14.9	19	39.7	57.2	2.2	79.2	M12	14	
150-159-M12-2D	15.0-15.9	19	41.2	58.7	2.3	80.7	M12	15	

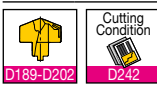

► SSC: Seat size code
 ► Matched with T-FLEXTEC holder

TCDM...-M12-3D



Head changeable drill holder with T-FLEXTEC type shank



- Drilling depth: 3xdiameter

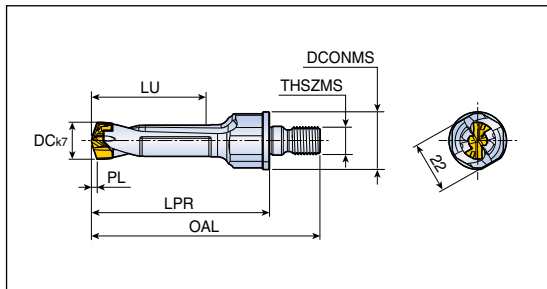

Designation	Dimension (mm)								Clamping key	
	DC	DCONMS	LU	LPR	PL	OAL	THSZMS	SSC		
TCDM 060-064-M12-3D	6.0-6.4	25	19.0	42.0	1.0	64.0	M12	6	K TCD D060-D099	
065-069-M12-3D	6.5-6.9	25	20.7	44.3	1.2	66.3	M12	6.5		
070-074-M12-3D	7.0-7.4	25	22.0	45.6	1.0	67.6	M12	7		
075-079-M12-3D	7.5-7.9	25	23.6	47.6	1.1	69.6	M12	7		
080-084-M12-3D	8.0-8.4	25	25.2	49.4	1.2	71.4	M12	8		
085-089-M12-3D	8.5-8.9	25	26.8	50.4	1.3	72.4	M12	8		
090-094-M12-3D	9.0-9.4	25	28.4	52.8	1.4	74.8	M12	9		
095-099-M12-3D	9.5-9.9	25	29.9	54.8	1.4	76.8	M12	9		
100-104-M12-3D	10.0-10.4	25	31.5	56.2	1.5	78.2	M12	10		K TCD D100-D199
105-109-M12-3D	10.5-10.9	25	33.1	58.2	1.6	80.2	M12	10		
110-114-M12-3D	11.0-11.4	25	34.7	59.6	1.7	81.6	M12	11		
115-119-M12-3D	11.5-11.9	25	36.3	61.6	1.8	83.6	M12	11		
120-124-M12-3D	12.0-12.4	25	37.8	63.0	1.8	85.0	M12	12		
125-129-M12-3D	12.5-12.9	25	39.4	64.0	1.9	86.0	M12	12		
130-134-M12-3D	13.0-13.4	25	41.0	66.6	2.0	88.6	M12	13		
135-139-M12-3D	13.5-13.9	25	42.6	68.6	2.1	90.6	M12	13		
140-144-M12-3D	14.0-14.4	25	44.1	70.2	2.1	92.2	M12	14		
145-149-M12-3D	14.5-14.9	25	45.7	72.2	2.2	94.2	M12	14		
150-159-M12-3D	15.0-15.9	25	47.3	73.7	2.3	95.7	M12	15	K TCD D200-D269	
160-169-M12-3D	16.0-16.9	25	50.4	77.3	2.4	99.3	M12	16		
170-179-M12-3D	17.0-17.9	25	53.6	80.9	2.6	102.9	M12	17		
180-189-M12-3D	18.0-18.9	25	56.7	84.5	2.7	106.5	M12	18		
190-199-M12-3D	19.0-19.9	25	59.9	88.0	2.9	110.0	M12	19		
200-209-M12-3D	20.0-20.9	25	63.0	91.6	3.0	113.6	M12	20		



- ▶ SSC: Seat size code
- ▶ Matched with T-FLEXTEC holder

TCDM...-M12-4D



Head changeable drill holder with T-FLEXTEC type shank



- Drilling depth: 4xdiameter

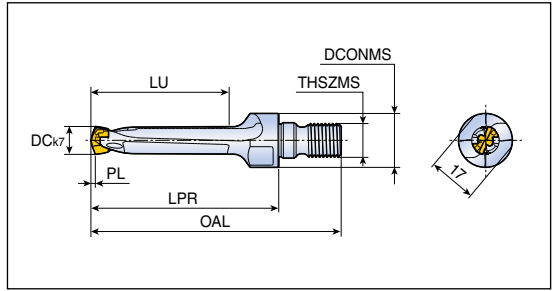

Designation	Dimension (mm)								Clamping key
	DC	DCONMS	LU	LPR	PL	OAL	THSZMS	SSC	
TCDM 100-104-M12-4D	10.0-10.4	19	48.7	66.2	1.5	88.2	M12	10	K TCD D100-D199
105-109-M12-4D	10.5-10.9	19	50.7	68.2	1.6	90.2	M12	10	
110-114-M12-4D	11.0-11.4	19	53.1	70.6	1.7	92.6	M12	11	
115-119-M12-4D	11.5-11.9	19	55.1	72.6	1.8	94.6	M12	11	
120-124-M12-4D	12.0-12.4	19	57.5	75.0	1.8	97.0	M12	12	
125-129-M12-4D	12.5-12.9	19	59.5	77.0	1.9	99.0	M12	12	
130-134-M12-4D	13.0-13.4	19	62.1	79.6	2.0	101.6	M12	13	
135-139-M12-4D	13.5-13.9	19	64.1	81.6	2.1	103.6	M12	13	
140-144-M12-4D	14.0-14.4	19	66.7	84.2	2.1	106.2	M12	14	
145-149-M12-4D	14.5-14.9	19	68.7	86.2	2.2	108.2	M12	14	
150-159-M12-4D	15.0-15.9	19	71.2	88.7	2.3	110.7	M12	15	



- ▶ SSC: Seat size code
- ▶ Matched with T-FLEXTEC holder

TFLEX-TCD-M12



T-FLEXTEC shank

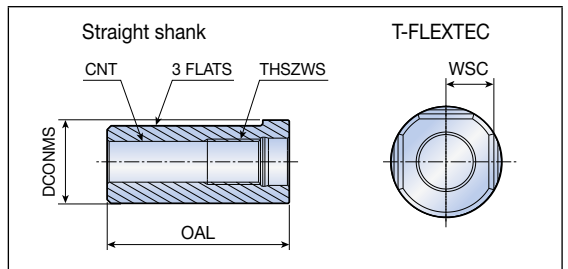

Designation	Dimension (mm)				CNT
	THSZWS	DCONMS	OAL	WSC	
TFLEX 160X36-TCD-M12	M12	16	36	7.5	UNF 5/16
1905X36-TCD-M12	M12	19.05	36	8.5	UNF 5/16
200X36-TCD-M12	M12	20	36	8.5	G 1/8
220X48-TCD-M12	M12	22	48	9.5	G 1/8
250X54-TCD-M12	M12	25	54	11	G 1/8
254X54-TCD-M12	M12	25.4	54	11	G 1/8

Modular drill heads

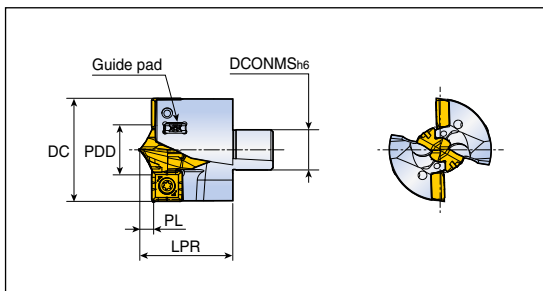

Designation	Dimension (mm)					Clamping Key	Insert	
	DC	DCONMS	LPR	PL	PDD		Center	Outer
TNDH 2600-C26-TP	26	10.4	24.9	3.98	15.9	K TCD D15-D16 CO	TCD-159-P-CO+	SPGX 06...DW
2700-C26-TP	27	10.4	25.4	4.14	16.9	K TCD D15-D16 CO	TCD-169-P-CO+	D204
2800-C28-TP	28	11.2	26.9	4.29	17.9	K TCD D17-D19 CO	TCD-179-P-CO+	
2900-C28-TP	29	11.2	26.6	3.97	15.9	K TCD D15-D16 CO	TCD-159-P-CO+	SPGX 07...DW
3000-C30-TP	30	12.0	28.3	4.14	16.9	K TCD D15-D16 CO	TCD-169-P-CO+	D204
3100-C30-TP	31	12.0	28.5	4.30	17.9	K TCD D17-D19 CO	TCD-179-P-CO+	
3200-C32-TP	32	12.8	30.3	4.46	18.9	K TCD D17-D19 CO	TCD-189-P-CO+	
3300-C32-TP	33	12.8	29.8	3.97	15.9	K TCD D15-D16 CO	TCD-159-P-CO+	SPGX 09...DW
3400-C34-TP	34	13.6	31.6	4.14	16.9	K TCD D15-D16 CO	TCD-169-P-CO+	D204
3500-C34-TP	35	13.6	31.8	4.30	17.9	K TCD D17-D19 CO	TCD-179-P-CO+	
3600-C36-TP	36	14.4	33.5	4.46	18.9	K TCD D17-D19 CO	TCD-189-P-CO+	
3700-C36-TP	37	14.4	33.3	4.14	16.9	K TCD D15-D16 CO	TCD-169-P-CO+	SPGX 11...DW
3800-C38-TP	38	15.2	35.0	4.30	17.9	K TCD D17-D19 CO	TCD-179-P-CO+	D204
3900-C38-TP	39	15.2	35.2	4.46	18.9	K TCD D17-D19 CO	TCD-189-P-CO+	
4000-C40-TP	40	16.0	36.9	4.62	19.9	K TCD D17-D19 CO	TCD-199-P-CO+	
4100-C40-TP	41	16.0	37.1	4.78	20.9	K TCD D20-D21 CO	TCD-209-P-CO+	
4200-C42-TP	42	16.8	38.9	4.95	21.9	K TCD D20-D21 CO	TCD-219-P-CO+	
4300-C42-TP	43	16.8	38.9	5.11	22.9	K TCD D22-D23 CO	TCD-229-P-CO+	

- ▶ DCONMS: Holder connection size
- ▶ Guide pad is sold separately from drill head

Spare parts

Designation	For double pitch screw		For SPGX		For Guide pad	
	Screw1	Wrench1	Screw2	Wrench2	Screw3	Wrench3
TNDH 2600-2800	TDPS 0512-T7	TD 7	TS 220521/HG	TD 7	TS 200431/HG-P	TD 6P
TNDH 2900-3200	TDPS 0512-T7	TD 7	TS 250641	TD 8	TS 200431/HG-P	TD 6P
TNDH 3300-3500	TDPS 0512-T7	TD 7	TS 350881	TD 10	TS 200431/HG-P	TD 6P
TNDH 3600	TDPS 0618-T8	TD 8	TS 350881	TD 10	TS 200431/HG-P	TD 6P
TNDH 3700-4300	TDPS 0618-T8	TD 8	TS 400931	TD 15	TS 200431/HG-P	TD 6P



MDB...T2-3

Modular drill holders - Weldon type shank



- Drilling depth: 3x diameter

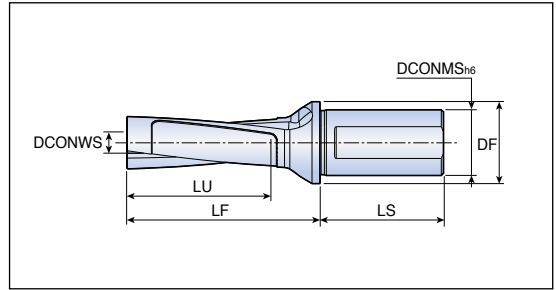

Designation	Dimension (mm)						
	DC	DCONWS	DCONMS	DF	LU	LF	LS
MDB D26/27-081-32T2-C26-3	26-27	10.4	32	40	60	94.3	60
D28/29-087-32T2-C28-3	28-29	11.2	32	40	64	100.5	60
D30/31-093-32T2-C30-3	30-31	12.0	32	40	69	105.5	60
D32/33-099-32T2-C32-3	32-33	12.8	32	40	73	111.7	60
D34/35-105-40T2-C34-3	34-35	13.6	40	50	78	120.2	68
D36/37-111-40T2-C36-3	36-37	14.4	40	50	82	126.5	68
D38/39-117-40T2-C38-3	38-39	15.2	40	50	86	131.4	68
D40/41-123-40T2-C40-3	40-41	16.0	40	50	91	137.6	68
D42/43-129-40T2-C42-3	42-43	16.8	40	50	95	143.8	68
D44/45-135-40T2-C44-3	44-45	17.6	40	50	99	150.0	68
D46/47-141-50T2-C46-3	46-47	18.4	50	60	104	154.5	80
D48/50-150-50T2-C48-3	48-50	19.2	50	60	111	160.9	80

- ▶ DC: Cutting diameter range
- ▶ DCONWS: Modular head connection size
- ▶ Refer to the Modular head information on page [D75-D76](#)

Spare parts

Designation	Wrench	Wrench handle		
MDB D26/27-D34/35-3	BLD H-W2.5x210	SW6-T-SH		
MDB D36/37-D42/43-3	BLD H-W3.0x225	SW6-T-SH		
MDB D44/45-D48/50-3	BLD H-W4.0x255	SW6-T-SH		

- ▶ Wrench: Disassemble the modular head from the modular body (Insert from the rear shank)



MDB...T2-5

Modular drill holders - Weldon type shank



- Drilling depth: 5x diameter

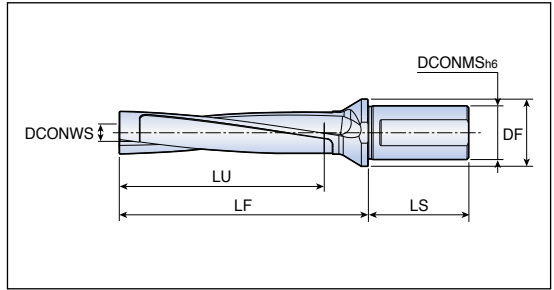

Designation	Dimension (mm)						
	DC	DCONWS	DCONMS	DF	LU	LF	LS
MDB D26/27-135-32T2-C26-5	26-27	10.4	32	40	114	148.3	60
D28/29-145-32T2-C28-5	28-29	11.2	32	40	122	158.5	60
D30/31-155-32T2-C30-5	30-31	12.0	32	40	131	167.5	60
D32/33-165-32T2-C32-5	32-33	12.8	32	40	139	177.7	60
D34/35-175-40T2-C34-5	34-35	13.6	40	50	148	190.2	68
D36/37-185-40T2-C36-5	36-37	14.4	40	50	156	200.5	68
D38/39-195-40T2-C38-5	38-39	15.2	40	50	164	209.4	68
D40/41-205-40T2-C40-5	40-41	16.0	40	50	173	219.6	68
D42/43-215-40T2-C42-5	42-43	16.8	40	50	181	229.8	68
D44/45-225-40T2-C44-5	44-45	17.6	40	50	189	240.0	68
D46/47-235-50T2-C46-5	46-47	18.4	50	60	198	248.5	80
D48/50-250-50T2-C48-5	48-50	19.2	50	60	211	258.9	80

- ▶ DC: Cutting diameter range
- ▶ DCONWS: Modular head connection size
- ▶ Refer to the Modular head information on page D75-D76

Spare parts

Designation	Wrench	Wrench handle		
MDB D26/27-D34/35-5	BLD H-W2.5x280	SW6-T-SH		
MDB D36/37-D42/43-5	BLD H-W3.0x310	SW6-T-SH		
MDB D44/45-D48/50-5	BLD H-W4.0x350	SW6-T-SH		

- ▶ Wrench: Disassemble the modular head from the modular body (Insert from the rear shank)



MDB...T2-7

Modular drill holders - Weldon type shank



- Drilling depth: 7xdiameter

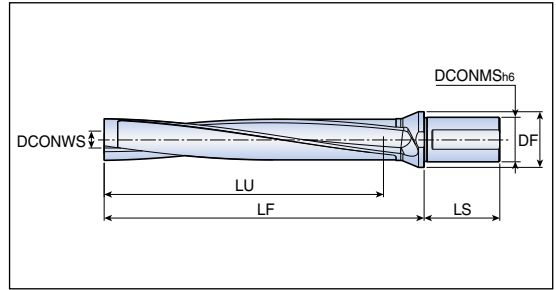

Designation	Dimension (mm)						
	DC	DCONWS	DCONMS	DF	LU	LF	LS
MDB D26/27-189-32T2-C26-7	26-27	10.4	32	40	168	202.3	60
D28/29-203-32T2-C28-7	28-29	11.2	32	40	180	216.5	60
D30/31-217-32T2-C30-7	30-31	12.0	32	40	193	229.5	60
D32/33-231-32T2-C32-7	32-33	12.8	32	40	205	243.7	60
D34/35-245-40T2-C34-7	34-35	13.6	40	50	218	260.2	68
D36/37-259-40T2-C36-7	36-37	14.4	40	50	230	274.5	68
D38/39-273-40T2-C38-7	38-39	15.2	40	50	242	287.4	68
D40/41-287-40T2-C40-7	40-41	16.0	40	50	255	301.6	68

- ▶ DC: Cutting diameter range
- ▶ DCONWS: Modular head connection size
- ▶ Refer to the Modular head information on page [D75-D76](#)

Spare parts

Designation	Wrench	Wrench handle		
MDB D26/27-7	BLD H-W2.5x280	SW6-T-SH		
MDB D28/29-D34/35-7	BLD H-W2.5x350	SW6-T-SH		
MDB D36/37-D40/41-7	BLD H-W3.0x400	SW6-T-SH		

- ▶ Wrench: Disassemble the modular head from the modular body (Insert from the rear shank)



Head changeable drill holders - Weldon type shank



- Drilling depth: 3x diameter

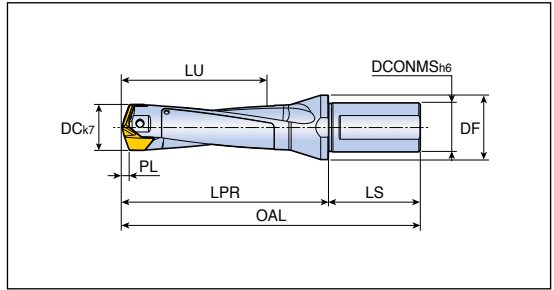

Designation	Dimension (mm)							
	DC	DCONMS	DF	LU	LPR	LS	PL	SSC
LCD 200-209-25T2-3D	20.0-20.9	25	32	63	92.1	56	3.11	20
210-219-25T2-3D	21.0-21.9	25	32	66	95.3	56	3.29	21
220-229-25T2-3D	22.0-22.9	25	32	69	98.4	56	3.42	22
230-239-25T2-3D	23.0-23.9	25	32	73	101.6	56	3.60	23
240-249-32T2-3D	24.0-24.9	32	40	76	110.7	60	3.73	24
250-259-32T2-3D	25.0-25.9	32	40	79	113.9	60	3.91	25
260-269-32T2-3D	26.0-26.9	32	40	82	117.0	60	4.04	26
270-279-32T2-3D	27.0-27.9	32	40	85	120.2	60	4.22	27
280-289-32T2-3D	28.0-28.9	32	40	88	128.4	60	4.35	28
290-299-32T2-3D	29.0-29.9	32	40	92	131.5	60	4.53	29
300-309-32T2-3D	30.0-30.9	32	42	95	134.7	60	4.67	30
310-319-32T2-3D	31.0-31.9	32	42	98	137.9	60	4.85	31
320-329-40T2-3D	32.0-32.9	40	48	101	143.0	68	4.98	32
330-339-40T2-3D	33.0-33.9	40	48	104	146.2	68	5.16	33
340-349-40T2-3D	34.0-34.9	40	48	107	149.3	68	5.34	34
350-359-40T2-3D	35.0-35.9	40	48	110	152.4	68	5.44	35
360-369-40T2-3D	36.0-36.9	40	48	114	155.6	68	5.62	36
370-379-40T2-3D	37.0-37.9	40	48	117	158.8	68	5.80	37
380-389-40T2-3D	38.0-38.9	40	50	120	166.9	68	5.91	38
390-399-40T2-3D	39.0-39.9	40	50	123	170.1	68	6.09	39
400-410-40T2-3D	40.0-41.0	40	50	126	173.3	68	6.27	40

► OAL: LPR+LS ► SSC: Seat size code

Spare parts

Designation	Screw	Wrench	Wrench handle	
LCD 200-219-3D	TS 40178D25	BLD T20/S7	SW6-T-SH	
LCD 220-239-3D	TS 40198D28	BLD T20/S7	SW6-T-SH	
LCD 240-259-3D	TS 40210D3	BLD T20/S7	SW6-T-SH	
LCD 260-279-3D	TS 50230D3	BLD T20/S7	SW6-T-SH	
LCD 280-299-3D	TS 50250D35	BLD T25/S7	SW6-T-SH	
LCD 300-319-3D	TS 60265D4	BLD T25/S7	SW6-T-SH	
LCD 320-349-3D	TS 60285D42	BLD T25/S7	SW6-T-SH	
LCD 350-379-3D	TS 60320D5	BLD T25/S7	SW6-T-SH	
LCD 380-410-3D	TS 80340D6	BLD T25/S7	SW6-T-SH	



Head changeable drill holders - Weldon type shank



- Drilling depth: 5xdiameter

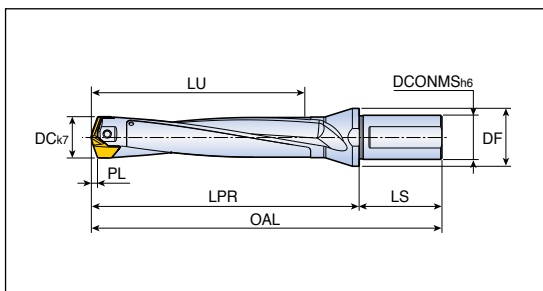

Designation	Dimension (mm)							
	DC	DCONMS	DF	LU	LPR	LS	PL	SSC
LCD 200-209-25T2-5D	20.0-20.9	25	32	103	132.1	56	3.11	20
210-219-25T2-5D	21.0-21.9	25	32	108	137.3	56	3.29	21
220-229-25T2-5D	22.0-22.9	25	32	113	142.4	56	3.42	22
230-239-25T2-5D	23.0-23.9	25	32	119	147.6	56	3.60	23
240-249-32T2-5D	24.0-24.9	32	40	124	158.7	60	3.73	24
250-259-32T2-5D	25.0-25.9	32	40	129	163.9	60	3.91	25
260-269-32T2-5D	26.0-26.9	32	40	134	169.0	60	4.04	26
270-279-32T2-5D	27.0-27.9	32	40	139	174.2	60	4.22	27
280-289-32T2-5D	28.0-28.9	32	40	144	184.4	60	4.35	28
290-299-32T2-5D	29.0-29.9	32	40	150	189.5	60	4.53	29
300-309-32T2-5D	30.0-30.9	32	42	155	194.7	60	4.67	30
310-319-32T2-5D	31.0-31.9	32	42	160	199.9	60	4.85	31
320-329-40T2-5D	32.0-32.9	40	48	165	207.0	68	4.98	32
330-339-40T2-5D	33.0-33.9	40	48	170	212.2	68	5.16	33
340-349-40T2-5D	34.0-34.9	40	48	175	217.3	68	5.34	34
350-359-40T2-5D	35.0-35.9	40	48	180	222.4	68	5.44	35
360-369-40T2-5D	36.0-36.9	40	48	186	227.6	68	5.62	36
370-379-40T2-5D	37.0-37.9	40	48	191	232.8	68	5.80	37
380-389-40T2-5D	38.0-38.9	40	50	196	242.9	68	5.91	38
390-399-40T2-5D	39.0-39.9	40	50	201	248.1	68	6.09	39
400-410-40T2-5D	40.0-41.0	40	50	206	253.3	68	6.27	40

- ▶ OAL: LPR+LS
- ▶ SSC: Seat size code

Spare parts

Designation	Screw	Wrench	Wrench handle	
LCD 200-219-5D	TS 40178D25	BLD T20/S7	SW6-T-SH	
LCD 220-239-5D	TS 40198D28	BLD T20/S7	SW6-T-SH	
LCD 240-259-5D	TS 40210D3	BLD T20/S7	SW6-T-SH	
LCD 260-279-5D	TS 50230D3	BLD T20/S7	SW6-T-SH	
LCD 280-299-5D	TS 50250D35	BLD T25/S7	SW6-T-SH	
LCD 300-319-5D	TS 60265D4	BLD T25/S7	SW6-T-SH	
LCD 320-349-5D	TS 60285D42	BLD T25/S7	SW6-T-SH	
LCD 350-379-5D	TS 60320D5	BLD T25/S7	SW6-T-SH	
LCD 380-410-5D	TS 80340D6	BLD T25/S7	SW6-T-SH	



Head changeable drill holders - Weldon type shank



- Drilling depth: 8x diameter

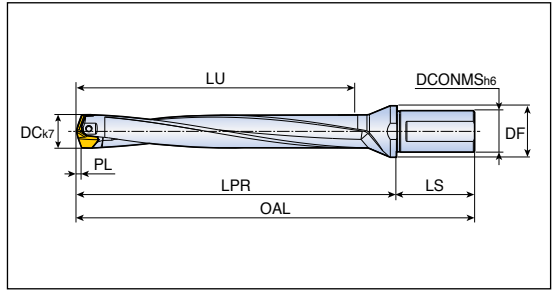

Designation	Dimension (mm)							
	DC	DCONMS	DF	LU	LPR	LS	PL	SSC
LCD 200-209-25T2-8D	20.0-20.9	25	32	163.1	192.1	56	3.11	20
210-219-25T2-8D	21.0-21.9	25	32	171.3	200.1	56	3.29	21
220-229-25T2-8D	22.0-22.9	25	32	179.4	208.4	56	3.42	22
230-239-25T2-8D	23.0-23.9	25	32	187.6	216.4	56	3.60	23
240-249-32T2-8D	24.0-24.9	32	40	195.7	230.7	60	3.73	24
250-259-32T2-8D	25.0-25.9	32	40	203.9	238.7	60	3.91	25
260-269-32T2-8D	26.0-26.9	32	40	212.0	247.0	60	4.04	26
270-279-32T2-8D	27.0-27.9	32	40	220.2	255.0	60	4.22	27
280-289-32T2-8D	28.0-28.9	32	40	228.4	268.4	60	4.35	28
290-299-32T2-8D	29.0-29.9	32	40	236.5	276.4	60	4.53	29
300-309-32T2-8D	30.0-30.9	32	42	244.7	284.7	60	4.67	30
310-319-32T2-8D	31.0-31.9	32	42	252.9	292.7	60	4.85	31
320-329-40T2-8D	32.0-32.9	40	48	261.0	303.0	68	4.98	32
330-339-40T2-8D	33.0-33.9	40	48	269.2	311.0	68	5.16	33
340-349-40T2-8D	34.0-34.9	40	48	277.3	319.0	68	5.34	34
350-359-40T2-8D	35.0-35.9	40	48	285.4	327.4	68	5.44	35
360-369-40T2-8D	36.0-36.9	40	48	293.6	335.4	68	5.62	36
370-379-40T2-8D	37.0-37.9	40	48	301.8	343.4	68	5.80	37
380-389-40T2-8D	38.0-38.9	40	50	309.9	356.9	68	5.91	38
390-399-40T2-8D	39.0-39.9	40	50	318.1	364.9	68	6.09	39
400-410-40T2-8D	40.0-41.0	40	50	326.3	372.9	68	6.27	40

► OAL: LPR+LS ► SSC: Seat size code ► It is recommended to make the pilot hole with a 3D holder

Spare parts

Designation	Screw	Wrench	Wrench handle
LCD 200-219-8D	TS 40178D25	BLD T20/S7	SW6-T-SH
LCD 220-239-8D	TS 40198D28	BLD T20/S7	SW6-T-SH
LCD 240-259-8D	TS 40210D3	BLD T20/S7	SW6-T-SH
LCD 260-279-8D	TS 50230D3	BLD T20/S7	SW6-T-SH
LCD 280-299-8D	TS 50250D35	BLD T25/S7	SW6-T-SH
LCD 300-319-8D	TS 60265D4	BLD T25/S7	SW6-T-SH
LCD 320-349-8D	TS 60285D42	BLD T25/S7	SW6-T-SH
LCD 350-379-8D	TS 60320D5	BLD T25/S7	SW6-T-SH
LCD 380-410-8D	TS 80340D6	BLD T25/S7	SW6-T-SH

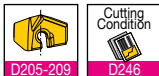

3HD...FI3

3 flute solid carbide drills for flat bottom holes



• Drilling depth: 3x diameter

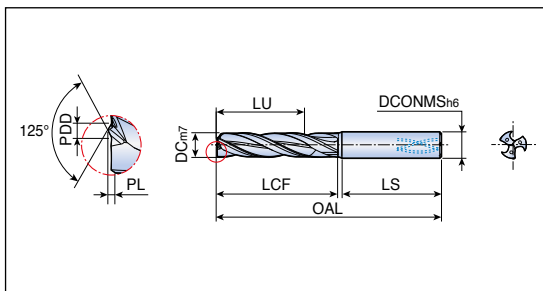

Designation	Dimension (mm)								Grade
	DC	DCONMS	OAL	LU	LCF	LS	PDD	PL	TT5130
3HD 040-017-06 FI3	4.0	6	66	17	25	35	0.77	0.43	●
045-017-06 FI3	4.5	6	66	17	25	35	0.86	0.45	●
050-020-06 FI3	5.0	6	66	20	29	36	0.97	0.47	●
055-020-06 FI3	5.5	6	66	20	29	36	1.08	0.58	●
060-020-06 FI3	6.0	6	66	20	29	36	1.08	0.58	●
065-024-08 FI3	6.5	8	79	24	35	36	1.26	0.62	●
070-024-08 FI3	7.0	8	79	24	35	36	1.26	0.62	●
075-029-08 FI3	7.5	8	79	29	42	36	1.44	0.66	●
080-029-08 FI3	8.0	8	79	29	42	36	1.44	0.66	●
085-035-10 FI3	8.5	10	89	35	48	40	1.62	0.79	●
090-035-10 FI3	9.0	10	89	35	48	40	1.62	0.79	●
095-035-10 FI3	9.5	10	89	35	48	40	1.80	0.82	●
100-035-10 FI3	10.0	10	89	35	48	40	1.80	0.82	●
105-040-12 FI3	10.5	12	102	40	55	45	1.98	0.95	●
110-040-12 FI3	11.0	12	102	40	55	45	1.98	0.95	●
115-040-12 FI3	11.5	12	102	40	56	45	2.16	0.98	●
120-040-12 FI3	12.0	12	102	40	56	45	2.16	0.98	●

• Standard items



Solid carbide drills without oil holes



- Drilling depth: 3xdiameter

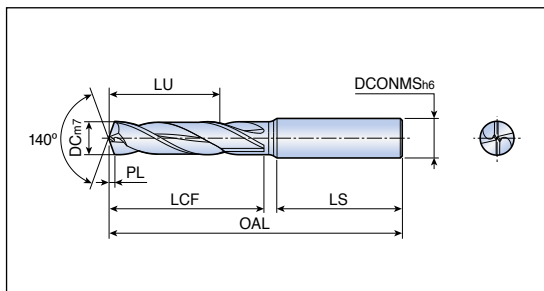

Designation	Dimension (mm)							Grade
	DC	DCONMS	OAL	LU	LCF	LS	PL	TT9030
NHD 030-014-06 PE3	3.0	6	62	14	21	34	0.5	●
031-014-06 PE3	3.1	6	62	14	21	34	0.5	●
032-014-06 PE3	3.2	6	62	14	21	34	0.5	●
033-014-06 PE3	3.3	6	62	14	21	34	0.5	●
034-014-06 PE3	3.4	6	62	14	21	34	0.5	●
035-014-06 PE3	3.5	6	62	14	21	34	0.6	●
036-014-06 PE3	3.6	6	62	14	21	34	0.6	●
037-014-06 PE3	3.7	6	62	14	21	34	0.6	●
038-017-06 PE3	3.8	6	66	17	25	35	0.6	●
039-017-06 PE3	3.9	6	66	17	25	35	0.6	●
040-017-06 PE3	4.0	6	66	17	25	35	0.6	●
041-017-06 PE3	4.1	6	66	17	25	35	0.7	●
042-017-06 PE3	4.2	6	66	17	25	35	0.7	●
043-017-06 PE3	4.3	6	66	17	25	35	0.7	●
044-017-06 PE3	4.4	6	66	17	25	35	0.7	●
045-017-06 PE3	4.5	6	66	17	25	35	0.7	●
046-017-06 PE3	4.6	6	66	17	25	35	0.7	●
047-017-06 PE3	4.7	6	66	17	25	35	0.8	●
048-020-06 PE3	4.8	6	66	20	29	36	0.8	●
049-020-06 PE3	4.9	6	66	20	29	36	0.8	●
050-020-06 PE3	5.0	6	66	20	29	36	0.8	●
051-020-06 PE3	5.1	6	66	20	29	36	0.8	●
052-020-06 PE3	5.2	6	66	20	29	36	0.8	●
053-020-06 PE3	5.3	6	66	20	29	36	0.8	●
054-020-06 PE3	5.4	6	66	20	29	36	0.8	●
055-020-06 PE3	5.5	6	66	20	29	36	0.9	●
056-020-06 PE3	5.6	6	66	20	29	36	0.9	●
057-020-06 PE3	5.7	6	66	20	29	36	0.9	●
058-020-06 PE3	5.8	6	66	20	29	36	0.9	●
059-020-06 PE3	5.9	6	66	20	29	36	0.9	●
060-020-06 PE3	6.0	6	66	20	29	36	0.9	●
061-024-08 PE3	6.1	8	79	24	35	36	1.0	●
062-024-08 PE3	6.2	8	79	24	35	36	1.0	●
063-024-08 PE3	6.3	8	79	24	35	36	1.0	●
064-024-08 PE3	6.4	8	79	24	35	36	1.0	●

- : Standard items



Solid carbide drills without oil holes



• Drilling depth: 3xdiameter

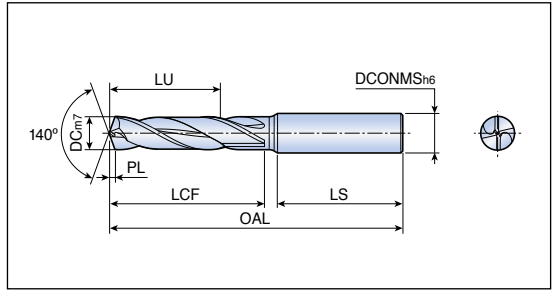

Designation	Dimension (mm)							Grade
	DC	DCONMS	OAL	LU	LCF	LS	PL	TT9030
NHD 065-024-08 PE3	6.5	8	79	24	35	36	1.0	●
066-024-08 PE3	6.6	8	79	24	35	36	1.0	●
067-024-08 PE3	6.7	8	79	24	35	36	1.1	●
068-024-08 PE3	6.8	8	79	24	35	36	1.1	●
069-024-08 PE3	6.9	8	79	24	35	36	1.1	●
070-024-08 PE3	7.0	8	79	24	35	36	1.1	●
071-029-08 PE3	7.1	8	79	29	42	36	1.1	●
072-029-08 PE3	7.2	8	79	29	42	36	1.1	●
073-029-08 PE3	7.3	8	79	29	42	36	1.1	●
074-029-08 PE3	7.4	8	79	29	42	36	1.2	●
075-029-08 PE3	7.5	8	79	29	42	36	1.2	●
076-029-08 PE3	7.6	8	79	29	42	36	1.2	●
077-029-08 PE3	7.7	8	79	29	42	36	1.2	●
078-029-08 PE3	7.8	8	79	29	42	36	1.2	●
079-029-08 PE3	7.9	8	79	29	42	36	1.3	●
080-029-08 PE3	8.0	8	79	29	42	36	1.3	●
081-035-10 PE3	8.1	10	89	35	48	40	1.3	●
082-035-10 PE3	8.2	10	89	35	48	40	1.3	●
083-035-10 PE3	8.3	10	89	35	48	40	1.3	●
084-035-10 PE3	8.4	10	89	35	48	40	1.3	●
085-035-10 PE3	8.5	10	89	35	48	40	1.3	●
086-035-10 PE3	8.6	10	89	35	48	40	1.4	●
087-035-10 PE3	8.7	10	89	35	48	40	1.4	●
088-035-10 PE3	8.8	10	89	35	48	40	1.4	●
089-035-10 PE3	8.9	10	89	35	48	40	1.4	●
090-035-10 PE3	9.0	10	89	35	48	40	1.4	●
091-035-10 PE3	9.1	10	89	35	48	40	1.4	●
092-035-10 PE3	9.2	10	89	35	48	40	1.4	●
093-035-10 PE3	9.3	10	89	35	48	40	1.5	●
094-035-10 PE3	9.4	10	89	35	48	40	1.5	●
095-035-10 PE3	9.5	10	89	35	48	40	1.5	●
096-035-10 PE3	9.6	10	89	35	48	40	1.5	●
097-035-10 PE3	9.7	10	89	35	48	40	1.5	●
098-035-10 PE3	9.8	10	89	35	48	40	1.6	●
099-035-10 PE3	9.9	10	89	35	48	40	1.6	●

• Standard items



Solid carbide drills without oil holes



• Drilling depth: 5xdiameter

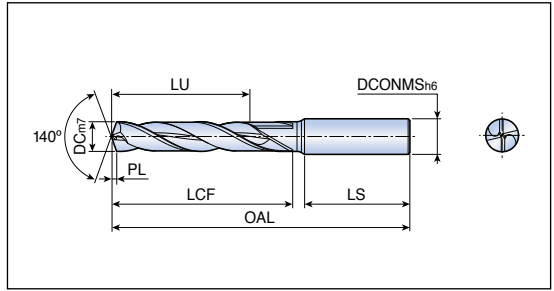

Designation	Dimension (mm)							Grade
	DC	DCONMS	OAL	LU	LCF	LS	PL	TT9030
NHD 030-023-06 PE5	3.0	6	66	23	29	34	0.5	●
031-023-06 PE5	3.1	6	66	23	29	34	0.5	●
032-023-06 PE5	3.2	6	66	23	29	34	0.5	●
033-023-06 PE5	3.3	6	66	23	29	34	0.5	●
034-023-06 PE5	3.4	6	66	23	29	34	0.5	●
035-023-06 PE5	3.5	6	66	23	29	34	0.6	●
036-023-06 PE5	3.6	6	66	23	29	34	0.6	●
037-023-06 PE5	3.7	6	66	23	29	34	0.6	●
038-029-06 PE5	3.8	6	74	29	37	35	0.6	●
039-029-06 PE5	3.9	6	74	29	37	35	0.6	●
040-029-06 PE5	4.0	6	74	29	37	35	0.6	●
041-029-06 PE5	4.1	6	74	29	37	35	0.7	●
042-029-06 PE5	4.2	6	74	29	37	35	0.7	●
043-029-06 PE5	4.3	6	74	29	37	35	0.7	●
044-029-06 PE5	4.4	6	74	29	37	35	0.7	●
045-029-06 PE5	4.5	6	74	29	37	35	0.7	●
046-029-06 PE5	4.6	6	74	29	37	35	0.7	●
047-029-06 PE5	4.7	6	74	29	37	35	0.8	●
048-035-06 PE5	4.8	6	82	35	45	36	0.8	●
049-035-06 PE5	4.9	6	82	35	45	36	0.8	●
050-035-06 PE5	5.0	6	82	35	45	36	0.8	●
051-035-06 PE5	5.1	6	82	35	45	36	0.8	●
052-035-06 PE5	5.2	6	82	35	45	36	0.8	●
053-035-06 PE5	5.3	6	82	35	45	36	0.8	●
054-035-06 PE5	5.4	6	82	35	45	36	0.8	●
055-035-06 PE5	5.5	6	82	35	45	36	0.9	●
056-035-06 PE5	5.6	6	82	35	45	36	0.9	●
057-035-06 PE5	5.7	6	82	35	45	36	0.9	●
058-035-06 PE5	5.8	6	82	35	45	36	0.9	●
059-035-06 PE5	5.9	6	82	35	45	36	0.9	●
060-035-06 PE5	6.0	6	82	35	45	36	0.9	●
061-043-08 PE5	6.1	8	91	43	54	36	1.0	●
062-043-08 PE5	6.2	8	91	43	54	36	1.0	●
063-043-08 PE5	6.3	8	91	43	54	36	1.0	●
064-043-08 PE5	6.4	8	91	43	54	36	1.0	●

• Standard items



NHD...PE5



Solid carbide drills without oil holes



- Drilling depth: 5xdiameter

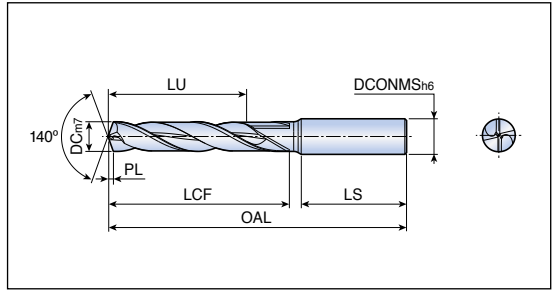

Designation	Dimension (mm)							Grade TT9030
	DC	DCONMS	OAL	LU	LCF	LS	PL	
NHD 065-043-08 PE5	6.5	8	91	43	54	36	1.0	●
066-043-08 PE5	6.6	8	91	43	54	36	1.0	●
067-043-08 PE5	6.7	8	91	43	54	36	1.1	●
068-043-08 PE5	6.8	8	91	43	54	36	1.1	●
069-043-08 PE5	6.9	8	91	43	54	36	1.1	●
070-043-08 PE5	7.0	8	91	43	54	36	1.1	●
071-043-08 PE5	7.1	8	91	43	54	36	1.1	●
072-043-08 PE5	7.2	8	91	43	54	36	1.1	●
073-043-08 PE5	7.3	8	91	43	54	36	1.1	●
074-043-08 PE5	7.4	8	91	43	54	36	1.2	●
075-043-08 PE5	7.5	8	91	43	54	36	1.2	●
076-043-08 PE5	7.6	8	91	43	54	36	1.2	●
077-043-08 PE5	7.7	8	91	43	54	36	1.2	●
078-043-08 PE5	7.8	8	91	43	54	36	1.2	●
079-043-08 PE5	7.9	8	91	43	54	36	1.3	●
080-043-08 PE5	8.0	8	91	43	54	36	1.3	●
081-049-10 PE5	8.1	10	103	49	62	40	1.3	●
082-049-10 PE5	8.2	10	103	49	62	40	1.3	●
083-049-10 PE5	8.3	10	103	49	62	40	1.3	●
084-049-10 PE5	8.4	10	103	49	62	40	1.3	●
085-049-10 PE5	8.5	10	103	49	62	40	1.3	●
086-049-10 PE5	8.6	10	103	49	62	40	1.4	●
087-049-10 PE5	8.7	10	103	49	62	40	1.4	●
088-049-10 PE5	8.8	10	103	49	62	40	1.4	●
089-049-10 PE5	8.9	10	103	49	62	40	1.4	●
090-049-10 PE5	9.0	10	103	49	62	40	1.4	●
091-049-10 PE5	9.1	10	103	49	62	40	1.4	●
092-049-10 PE5	9.2	10	103	49	62	40	1.4	●
093-049-10 PE5	9.3	10	103	49	62	40	1.5	●
094-049-10 PE5	9.4	10	103	49	62	40	1.5	●
095-049-10 PE5	9.5	10	103	49	62	40	1.5	●
096-049-10 PE5	9.6	10	103	49	62	40	1.5	●
097-049-10 PE5	9.7	10	103	49	62	40	1.5	●
098-049-10 PE5	9.8	10	103	49	62	40	1.6	●
099-049-10 PE5	9.9	10	103	49	62	40	1.6	●

●: Standard items



NHD...PE5



Solid carbide drills without oil holes



- Drilling depth: 5x diameter

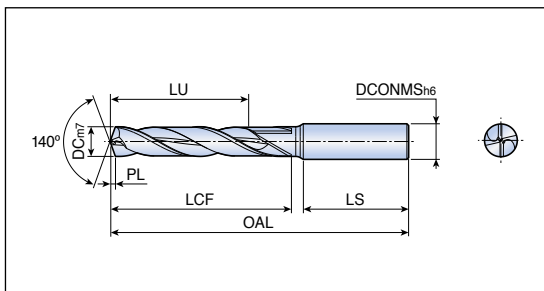

Designation	Dimension (mm)							Grade
	DC	DCONMS	OAL	LU	LCF	PL	LS	TT9030
NHD 100-049-10 PE5	10.0	10	103	49	62	1.6	40	●
101-056-12 PE5	10.1	12	118	56	71	1.6	45	●
102-056-12 PE5	10.2	12	118	56	71	1.6	45	●
103-056-12 PE5	10.3	12	118	56	71	1.6	45	●
104-056-12 PE5	10.4	12	118	56	71	1.6	45	●
105-056-12 PE5	10.5	12	118	56	71	1.6	45	●
106-056-12 PE5	10.6	12	118	56	71	1.7	45	●
107-056-12 PE5	10.7	12	118	56	71	1.7	45	●
108-056-12 PE5	10.8	12	118	56	71	1.7	45	●
109-056-12 PE5	10.9	12	118	56	71	1.7	45	●
110-056-12 PE5	11.0	12	118	56	71	1.7	45	●
111-056-12 PE5	11.1	12	118	56	72	1.7	45	●
112-056-12 PE5	11.2	12	118	56	72	1.8	45	●
113-056-12 PE5	11.3	12	118	56	72	1.8	45	●
114-056-12 PE5	11.4	12	118	56	72	1.8	45	●
115-056-12 PE5	11.5	12	118	56	72	1.8	45	●
116-056-12 PE5	11.6	12	118	56	72	1.8	45	●
117-056-12 PE5	11.7	12	118	56	72	1.9	45	●
118-056-12 PE5	11.8	12	118	56	72	1.9	45	●
119-056-12 PE5	11.9	12	118	56	72	1.9	45	●
120-056-12 PE5	12.0	12	118	56	72	1.9	45	●

• Standard items



NHD...PI3



Solid carbide drills with oil holes

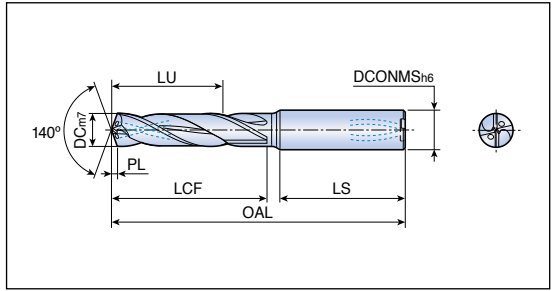

- Drilling depth: 3xdiameter



Designation	Dimension (mm)							Grade
	DC	DCONMS	OAL	LU	LCF	LS	PL	TT9030
NHD 030-014-06 PI3	3.0	6	62	14	21	34	0.5	●
031-014-06 PI3	3.1	6	62	14	21	34	0.5	●
032-014-06 PI3	3.2	6	62	14	21	34	0.5	●
033-014-06 PI3	3.3	6	62	14	21	34	0.5	●
034-014-06 PI3	3.4	6	62	14	21	34	0.5	●
035-014-06 PI3	3.5	6	62	14	21	34	0.6	●
036-014-06 PI3	3.6	6	62	14	21	34	0.6	●
037-014-06 PI3	3.7	6	62	14	21	34	0.6	●
038-017-06 PI3	3.8	6	66	17	25	35	0.6	●
039-017-06 PI3	3.9	6	66	17	25	35	0.6	●
040-017-06 PI3	4.0	6	66	17	25	35	0.6	●
041-017-06 PI3	4.1	6	66	17	25	35	0.7	●
042-017-06 PI3	4.2	6	66	17	25	35	0.7	●
043-017-06 PI3	4.3	6	66	17	25	35	0.7	●
044-017-06 PI3	4.4	6	66	17	25	35	0.7	●
045-017-06 PI3	4.5	6	66	17	25	35	0.7	●
046-017-06 PI3	4.6	6	66	17	25	35	0.7	●
047-017-06 PI3	4.7	6	66	17	25	35	0.8	●
048-020-06 PI3	4.8	6	66	20	29	36	0.8	●
049-020-06 PI3	4.9	6	66	20	29	36	0.8	●
050-020-06 PI3	5.0	6	66	20	29	36	0.8	●
051-020-06 PI3	5.1	6	66	20	29	36	0.8	●
052-020-06 PI3	5.2	6	66	20	29	36	0.8	●
053-020-06 PI3	5.3	6	66	20	29	36	0.8	●
054-020-06 PI3	5.4	6	66	20	29	36	0.8	●
055-020-06 PI3	5.5	6	66	20	29	36	0.9	●
056-020-06 PI3	5.6	6	66	20	29	36	0.9	●
057-020-06 PI3	5.7	6	66	20	29	36	0.9	●
058-020-06 PI3	5.8	6	66	20	29	36	0.9	●
059-020-06 PI3	5.9	6	66	20	29	36	0.9	●
060-020-06 PI3	6.0	6	66	20	29	36	0.9	●
061-024-08 PI3	6.1	8	79	24	35	36	1.0	●
062-024-08 PI3	6.2	8	79	24	35	36	1.0	●
063-024-08 PI3	6.3	8	79	24	35	36	1.0	●
064-024-08 PI3	6.4	8	79	24	35	36	1.0	●

- Standard items



Solid carbide drills with oil holes



- Drilling depth: 3xdiameter

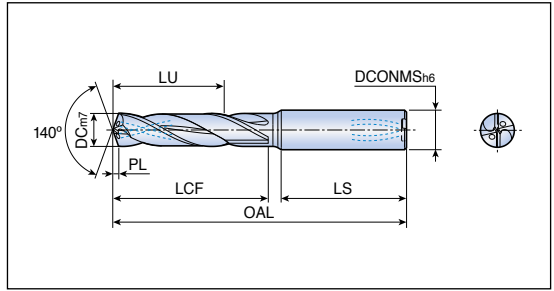

Designation	Dimension (mm)							Grade
	DC	DCONMS	OAL	LU	LCF	LS	PL	TT9030
NHD 065-024-08 PI3	6.5	8	79	24	35	36	1.0	•
066-024-08 PI3	6.6	8	79	24	35	36	1.0	•
067-024-08 PI3	6.7	8	79	24	35	36	1.1	•
068-024-08 PI3	6.8	8	79	24	35	36	1.1	•
069-024-08 PI3	6.9	8	79	24	35	36	1.1	•
070-024-08 PI3	7.0	8	79	24	35	36	1.1	•
071-029-08 PI3	7.1	8	79	29	42	36	1.1	•
072-029-08 PI3	7.2	8	79	29	42	36	1.1	•
073-029-08 PI3	7.3	8	79	29	42	36	1.1	•
074-029-08 PI3	7.4	8	79	29	42	36	1.2	•
075-029-08 PI3	7.5	8	79	29	42	36	1.2	•
076-029-08 PI3	7.6	8	79	29	42	36	1.2	•
077-029-08 PI3	7.7	8	79	29	42	36	1.2	•
078-029-08 PI3	7.8	8	79	29	42	36	1.2	•
079-029-08 PI3	7.9	8	79	29	42	36	1.3	•
080-029-08 PI3	8.0	8	79	29	42	36	1.3	•
081-035-10 PI3	8.1	10	89	35	48	40	1.3	•
082-035-10 PI3	8.2	10	89	35	48	40	1.3	•
083-035-10 PI3	8.3	10	89	35	48	40	1.3	•
084-035-10 PI3	8.4	10	89	35	48	40	1.3	•
085-035-10 PI3	8.5	10	89	35	48	40	1.3	•
086-035-10 PI3	8.6	10	89	35	48	40	1.4	•
087-035-10 PI3	8.7	10	89	35	48	40	1.4	•
088-035-10 PI3	8.8	10	89	35	48	40	1.4	•
089-035-10 PI3	8.9	10	89	35	48	40	1.4	•
090-035-10 PI3	9.0	10	89	35	48	40	1.4	•
091-035-10 PI3	9.1	10	89	35	48	40	1.4	•
092-035-10 PI3	9.2	10	89	35	48	40	1.4	•
093-035-10 PI3	9.3	10	89	35	48	40	1.5	•
094-035-10 PI3	9.4	10	89	35	48	40	1.5	•
095-035-10 PI3	9.5	10	89	35	48	40	1.5	•
096-035-10 PI3	9.6	10	89	35	48	40	1.5	•
097-035-10 PI3	9.7	10	89	35	48	40	1.5	•
098-035-10 PI3	9.8	10	89	35	48	40	1.6	•
099-035-10 PI3	9.9	10	89	35	48	40	1.6	•

- Standard items



NHD...PI3



Solid carbide drills with oil holes



- Drilling depth: 3xdiameter

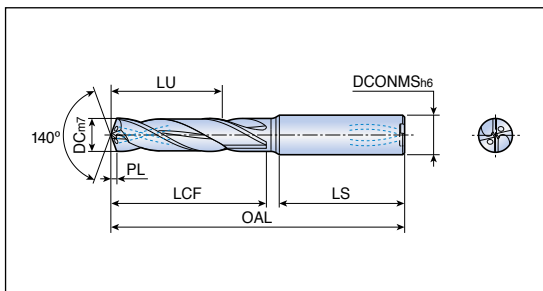

Designation	Dimension (mm)							Grade
	DC	DCONMS	OAL	LU	LCF	LS	PL	TT9030
NHD 100-035-10 PI3	10.0	10	89	35	48	40	1.6	●
101-040-12 PI3	10.1	12	102	40	55	45	1.6	●
102-040-12 PI3	10.2	12	102	40	55	45	1.6	●
103-040-12 PI3	10.3	12	102	40	55	45	1.6	●
104-040-12 PI3	10.4	12	102	40	55	45	1.6	●
105-040-12 PI3	10.5	12	102	40	55	45	1.6	●
106-040-12 PI3	10.6	12	102	40	55	45	1.7	●
107-040-12 PI3	10.7	12	102	40	55	45	1.7	●
108-040-12 PI3	10.8	12	102	40	55	45	1.7	●
109-040-12 PI3	10.9	12	102	40	55	45	1.7	●
110-040-12 PI3	11.0	12	102	40	55	45	1.7	●
111-040-12 PI3	11.1	12	102	40	56	45	1.7	●
112-040-12 PI3	11.2	12	102	40	56	45	1.8	●
113-040-12 PI3	11.3	12	102	40	56	45	1.8	●
114-040-12 PI3	11.4	12	102	40	56	45	1.8	●
115-040-12 PI3	11.5	12	102	40	56	45	1.8	●
116-040-12 PI3	11.6	12	102	40	56	45	1.8	●
117-040-12 PI3	11.7	12	102	40	56	45	1.9	●
118-040-12 PI3	11.8	12	102	40	56	45	1.9	●
119-040-12 PI3	11.9	12	102	40	56	45	1.9	●
120-040-12 PI3	12.0	12	102	40	56	45	1.9	●



●: Standard items

Solid carbide drills with oil holes



- Drilling depth: 5x diameter

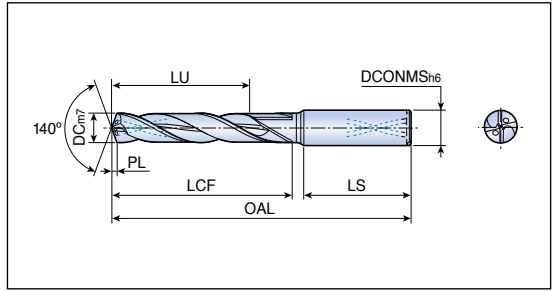

Designation	Dimension (mm)							Grade
	DC	DCONMS	OAL	LU	LCF	LS	PL	TT9030
NHD 030-023-06 PI5	3.0	6	66	23	29	34	0.5	●
031-023-06 PI5	3.1	6	66	23	29	34	0.5	●
032-023-06 PI5	3.2	6	66	23	29	34	0.5	●
033-023-06 PI5	3.3	6	66	23	29	34	0.5	●
034-023-06 PI5	3.4	6	66	23	29	34	0.5	●
035-023-06 PI5	3.5	6	66	23	29	34	0.6	●
036-023-06 PI5	3.6	6	66	23	29	34	0.6	●
037-023-06 PI5	3.7	6	66	23	29	34	0.6	●
038-029-06 PI5	3.8	6	74	29	37	35	0.6	●
039-029-06 PI5	3.9	6	74	29	37	35	0.6	●
040-029-06 PI5	4.0	6	74	29	37	35	0.6	●
041-029-06 PI5	4.1	6	74	29	37	35	0.7	●
042-029-06 PI5	4.2	6	74	29	37	35	0.7	●
043-029-06 PI5	4.3	6	74	29	37	35	0.7	●
044-029-06 PI5	4.4	6	74	29	37	35	0.7	●
045-029-06 PI5	4.5	6	74	29	37	35	0.7	●
046-029-06 PI5	4.6	6	74	29	37	35	0.7	●
047-029-06 PI5	4.7	6	74	29	37	35	0.8	●
048-035-06 PI5	4.8	6	82	35	45	36	0.8	●
049-035-06 PI5	4.9	6	82	35	45	36	0.8	●
050-035-06 PI5	5.0	6	82	35	45	36	0.8	●
051-035-06 PI5	5.1	6	82	35	45	36	0.8	●
052-035-06 PI5	5.2	6	82	35	45	36	0.8	●
053-035-06 PI5	5.3	6	82	35	45	36	0.8	●
054-035-06 PI5	5.4	6	82	35	45	36	0.8	●
055-035-06 PI5	5.5	6	82	35	45	36	0.9	●
056-035-06 PI5	5.6	6	82	35	45	36	0.9	●
057-035-06 PI5	5.7	6	82	35	45	36	0.9	●
058-035-06 PI5	5.8	6	82	35	45	36	0.9	●
059-035-06 PI5	5.9	6	82	35	45	36	0.9	●
060-035-06 PI5	6.0	6	82	35	45	36	0.9	●
061-043-08 PI5	6.1	8	91	43	54	36	1.0	●
062-043-08 PI5	6.2	8	91	43	54	36	1.0	●
063-043-08 PI5	6.3	8	91	43	54	36	1.0	●
064-043-08 PI5	6.4	8	91	43	54	36	1.0	●

- Standard items



NHD...PI5



Solid carbide drills with oil holes



- Drilling depth: 5xdiameter

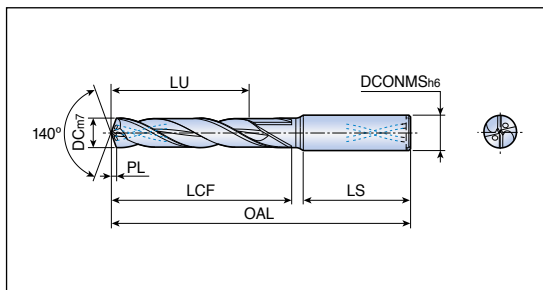

Designation	Dimension (mm)							Grade TT9030
	DC	DCONMS	OAL	LU	LCF	LS	PL	
NHD 065-043-08 PI5	6.5	8	91	43	54	36	1.0	●
066-043-08 PI5	6.6	8	91	43	54	36	1.0	●
067-043-08 PI5	6.7	8	91	43	54	36	1.1	●
068-043-08 PI5	6.8	8	91	43	54	36	1.1	●
069-043-08 PI5	6.9	8	91	43	54	36	1.1	●
070-043-08 PI5	7.0	8	91	43	54	36	1.1	●
071-043-08 PI5	7.1	8	91	43	54	36	1.1	●
072-043-08 PI5	7.2	8	91	43	54	36	1.1	●
073-043-08 PI5	7.3	8	91	43	54	36	1.1	●
074-043-08 PI5	7.4	8	91	43	54	36	1.2	●
075-043-08 PI5	7.5	8	91	43	54	36	1.2	●
076-043-08 PI5	7.6	8	91	43	54	36	1.2	●
077-043-08 PI5	7.7	8	91	43	54	36	1.2	●
078-043-08 PI5	7.8	8	91	43	54	36	1.2	●
079-043-08 PI5	7.9	8	91	43	54	36	1.3	●
080-043-08 PI5	8.0	8	91	43	54	36	1.3	●
081-049-10 PI5	8.1	10	103	49	62	40	1.3	●
082-049-10 PI5	8.2	10	103	49	62	40	1.3	●
083-049-10 PI5	8.3	10	103	49	62	40	1.3	●
084-049-10 PI5	8.4	10	103	49	62	40	1.3	●
085-049-10 PI5	8.5	10	103	49	62	40	1.3	●
086-049-10 PI5	8.6	10	103	49	62	40	1.4	●
087-049-10 PI5	8.7	10	103	49	62	40	1.4	●
088-049-10 PI5	8.8	10	103	49	62	40	1.4	●
089-049-10 PI5	8.9	10	103	49	62	40	1.4	●
090-049-10 PI5	9.0	10	103	49	62	40	1.4	●
091-049-10 PI5	9.1	10	103	49	62	40	1.4	●
092-049-10 PI5	9.2	10	103	49	62	40	1.4	●
093-049-10 PI5	9.3	10	103	49	62	40	1.5	●
094-049-10 PI5	9.4	10	103	49	62	40	1.5	●
095-049-10 PI5	9.5	10	103	49	62	40	1.5	●
096-049-10 PI5	9.6	10	103	49	62	40	1.5	●
097-049-10 PI5	9.7	10	103	49	62	40	1.5	●
098-049-10 PI5	9.8	10	103	49	62	40	1.6	●
099-049-10 PI5	9.9	10	103	49	62	40	1.6	●

- : Standard items



NHD...PI5



Solid carbide drills with oil holes



• Drilling depth: 5xdiameter

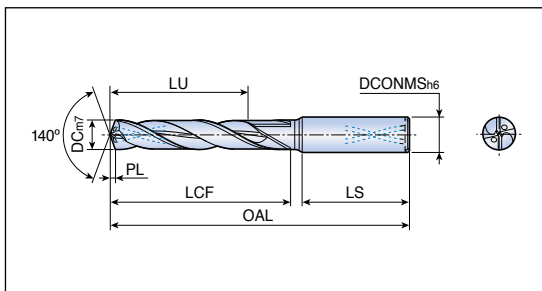

Designation	Dimension (mm)							Grade TT9030
	DC	DCONMS	OAL	LU	LCF	LS	PL	
NHD 100-049-10 PI5	10.0	10	103	49	62	40	1.6	•
101-056-12 PI5	10.1	12	118	56	71	45	1.6	•
102-056-12 PI5	10.2	12	118	56	71	45	1.6	•
103-056-12 PI5	10.3	12	118	56	71	45	1.6	•
104-056-12 PI5	10.4	12	118	56	71	45	1.6	•
105-056-12 PI5	10.5	12	118	56	71	45	1.6	•
106-056-12 PI5	10.6	12	118	56	71	45	1.7	•
107-056-12 PI5	10.7	12	118	56	71	45	1.7	•
108-056-12 PI5	10.8	12	118	56	71	45	1.7	•
109-056-12 PI5	10.9	12	118	56	71	45	1.7	•
110-056-12 PI5	11.0	12	118	56	71	45	1.7	•
111-056-12 PI5	11.1	12	118	56	72	45	1.7	•
112-056-12 PI5	11.2	12	118	56	72	45	1.8	•
113-056-12 PI5	11.3	12	118	56	72	45	1.8	•
114-056-12 PI5	11.4	12	118	56	72	45	1.8	•
115-056-12 PI5	11.5	12	118	56	72	45	1.8	•
116-056-12 PI5	11.6	12	118	56	72	45	1.8	•
117-056-12 PI5	11.7	12	118	56	72	45	1.9	•
118-056-12 PI5	11.8	12	118	56	72	45	1.9	•
119-056-12 PI5	11.9	12	118	56	72	45	1.9	•
120-056-12 PI5	12.0	12	118	56	72	45	1.9	•

• Standard items



NHD...KI3



Solid carbide drills with oil holes for cast iron machining

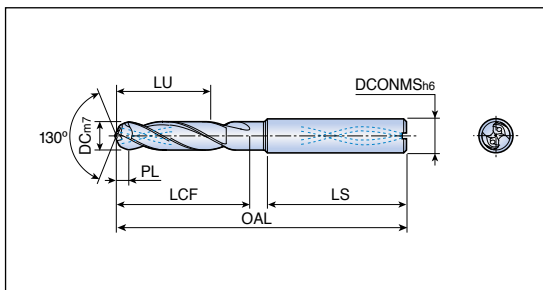

- Drilling depth: 3xdiameter



Designation	Dimension (mm)							Grade
	DC	DCONMS	OAL	LU	LCF	LS	PL	TT9030
NHD 030-014-06 KI3	3.0	6	62	14	20	34	1.4	●
033-014-06 KI3	3.3	6	62	14	20	34	1.6	●
035-014-06 KI3	3.5	6	62	14	20	34	1.7	●
040-017-06 KI3	4.0	6	66	17	24	35	1.9	●
041-017-06 KI3	4.1	6	66	17	24	35	2.0	●
042-017-06 KI3	4.2	6	66	17	24	35	2.0	●
045-017-06 KI3	4.5	6	66	17	24	35	2.2	●
046-017-06 KI3	4.6	6	66	17	24	35	2.2	●
050-020-06 KI3	5.0	6	66	20	27	36	2.4	●
051-020-06 KI3	5.1	6	66	20	27	36	2.5	●
052-020-06 KI3	5.2	6	66	20	27	36	2.5	●
055-020-06 KI3	5.5	6	66	20	27	36	2.6	●
060-020-06 KI3	6.0	6	66	20	27	36	2.9	●
061-024-08 KI3	6.1	8	79	24	34	36	2.9	●
065-024-08 KI3	6.5	8	79	24	34	36	3.1	●
067-024-08 KI3	6.7	8	79	24	34	36	3.2	●
068-024-08 KI3	6.8	8	79	24	34	36	3.3	●
070-024-08 KI3	7.0	8	79	24	34	36	3.4	●
075-029-08 KI3	7.5	8	79	29	40	36	3.6	●
080-029-08 KI3	8.0	8	79	29	40	36	3.8	●
081-035-10 KI3	8.1	10	89	35	45	40	3.9	●
085-035-10 KI3	8.5	10	89	35	45	40	4.1	●
087-035-10 KI3	8.7	10	89	35	45	40	4.2	●
089-035-10 KI3	8.9	10	89	35	45	40	4.3	●
090-035-10 KI3	9.0	10	89	35	45	40	4.3	●
095-035-10 KI3	9.5	10	89	35	45	40	4.6	●
100-035-10 KI3	10.0	10	89	35	45	40	4.8	●
103-040-12 KI3	10.3	12	102	40	53	45	4.9	●
105-040-12 KI3	10.5	12	102	40	53	45	5.0	●
110-040-12 KI3	11.0	12	102	40	53	45	5.3	●
115-040-12 KI3	11.5	12	102	40	53	45	5.5	●
120-040-12 KI3	12.0	12	102	40	53	45	5.8	●



- Standard items

NHD...KI5



Solid carbide drills with oil holes for cast iron machining



• Drilling depth: 5x diameter

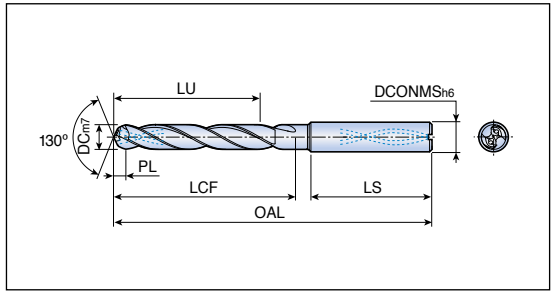

Designation	Dimension (mm)							Grade
	DC	DCONMS	OAL	LU	LCF	LS	PL	TT9030
NHD 030-023-06 KI5	3.0	6	66	23	27	34	1.4	●
033-023-06 KI5	3.3	6	66	23	27	34	1.6	●
035-023-06 KI5	3.5	6	66	23	27	34	1.7	●
040-029-06 KI5	4.0	6	74	29	34	35	1.9	●
042-029-06 KI5	4.2	6	74	29	34	35	2.0	●
045-029-06 KI5	4.5	6	74	29	35	35	2.2	●
046-029-06 KI5	4.6	6	74	29	35	35	2.2	●
050-035-06 KI5	5.0	6	82	35	43	36	2.4	●
052-035-06 KI5	5.2	6	82	35	43	36	2.5	●
055-035-06 KI5	5.5	6	82	35	43	36	2.6	●
060-035-06 KI5	6.0	6	82	35	43	36	2.9	●
065-043-08 KI5	6.5	8	91	43	52	36	3.1	●
067-043-08 KI5	6.7	8	91	43	52	36	3.2	●
068-043-08 KI5	6.8	8	91	43	52	36	3.3	●
070-043-08 KI5	7.0	8	91	43	52	36	3.4	●
075-043-08 KI5	7.5	8	91	43	52	36	3.6	●
080-043-08 KI5	8.0	8	91	43	52	36	3.8	●
081-049-10 KI5	8.1	10	103	49	59	40	3.9	●
085-049-10 KI5	8.5	10	103	49	59	40	4.1	●
087-049-10 KI5	8.7	10	103	49	59	40	4.2	●
089-049-10 KI5	8.9	10	103	49	59	40	4.3	●
090-049-10 KI5	9.0	10	103	49	59	40	4.3	●
095-049-10 KI5	9.5	10	103	49	59	40	4.6	●
100-049-10 KI5	10.0	10	103	49	59	40	4.8	●
103-056-12 KI5	10.3	12	118	56	69	45	4.9	●
105-056-12 KI5	10.5	12	118	56	69	45	5.0	●
110-056-12 KI5	11.0	12	118	56	69	45	5.3	●
115-056-12 KI5	11.5	12	118	56	69	45	5.5	●
120-056-12 KI5	12.0	12	118	56	69	45	5.8	●

● Standard items



T-CHAMFER...T1



Chamfering tools with solid carbide drill

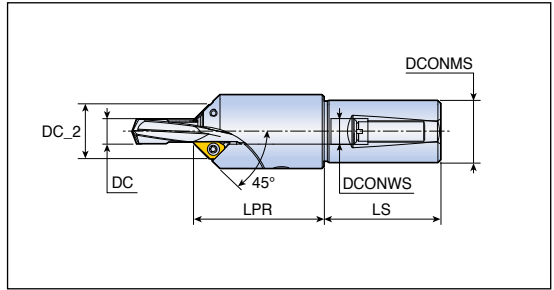

Designation	DC	Dimension (mm)					Insert
		DCONWS	DC_2	DCONMS	LPR	LS	
T-CHAMFER 080-20T1-06	7.1-8.0	8	18.8	20	47.4	50	XCGT 06...-C..
090-20T1-06	8.1-9.0	9	19.8	20	47.4	50	D210
100-32T1-09	9.1-10.0	10	24.9	32	67.3	60	XCGT 09...-C..
110-32T1-09	10.1-11.0	11	25.9	32	67.3	60	D210
120-32T1-09	11.1-12.0	12	26.9	32	67.3	60	
130-32T1-09	12.1-13.0	13	27.9	32	67.3	60	
140-32T1-09	13.1-14.0	14	28.4	32	67.3	60	
150-32T1-09	14.1-15.0	15	29.4	32	67.3	60	
160-32T1-09	15.1-16.0	16	30.4	32	67.3	60	
170-32T1-09	16.1-17.0	17	31.4	32	67.3	60	
180-32T1-09	17.1-18.0	18	32.4	32	67.3	60	
190-32T1-09	18.1-19.0	19	33.4	32	75.0	60	
200-32T1-09	19.1-20.0	20	34.4	32	75.0	60	

Spare parts

Designation	Side screw	Back screw	L-wrench	Insert screw	Wrench
T-CHAMFER 080 - 090	SS M6x1x6	M6x1-SP	L-W 3	TS 25064I	TD 8
T-CHAMFER 100 - 200	SS M10x1.5x10	M10x1.5-SP	L-W 5	TS 40093I	TD 15



TSL-NC

Drill sleeves for Swiss type automatic lathes (Fixed type, internal coolant)

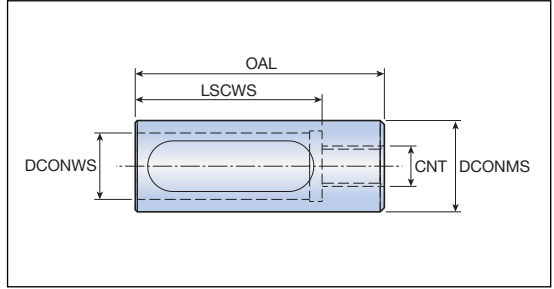

Designation	Dimension (mm)				
	DCONMS	DCONWS	LSCWS	OAL	CNT
TSL-NC 19.05-12	19.05	12.0	45	60	Rc 1/8
19.05-16	19.05	16.0	45	60	Rc 1/8
20-12	20.0	12.0	45	60	Rc 1/8
20-16	20.0	16.0	45	60	Rc 1/8
22-16	22.0	16.0	45	60	Rc 1/8
25-20	25.0	20.0	45	60	Rc 1/8
25.4-20	25.4	20.0	45	60	Rc 1/8
32-25	32.0	25.0	45	60	Rc 1/8

TSL-SW

Drill sleeves for Swiss type automatic lathes (Adjustable type, internal coolant)

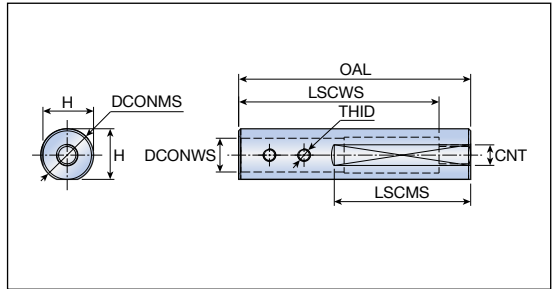

Designation	Dimension (mm)							
	DCONMS	DCONWS	LSCWS	LSCMS	OAL	H	THID	CNT
TSL-SW 22-12	22.0	12.0	95	65	110	21.0	M6	Rc 1/8
25-12	25.0	12.0	95	65	110	24.0	M8	Rc 1/8
25-16	25.0	16.0	95	65	110	24.0	M6	Rc 1/8
25.4-12	25.4	12.0	95	65	110	24.4	M8	Rc 1/8
25.4-16	25.4	16.0	95	65	110	24.4	M6	Rc 1/8
32-12	32.0	12.0	95	65	110	31.0	M8	Rc 1/8
32-16	32.0	16.0	95	65	110	31.0	M8	Rc 1/8
32-20	32.0	20.0	95	65	110	31.0	M8	Rc 1/8

Accessories

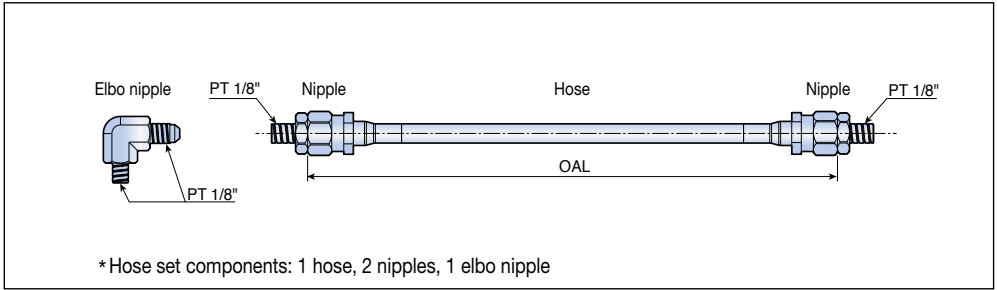

Hose set



Designation	Dimension (mm)	
	OAL (mm)	Max. pressure (bar)
S-TSL HOSE R1/8-220	220	100
R1/8-350	350	100

► Hose set is ordered separately

Spare parts

Designation	Mounting screw	Wrench		
				
TSL-SW 22-12	SS M6X1X5	L-W 3		
TSL-SW 25-12	SS M8X1.25X6	L-W 4		
TSL-SW 25-16	SS M6X1X5	L-W 3		
TSL-SW 25.4-12	SS M8X1.25X6	L-W 4		
TSL-SW 25.4-16	SS M6X1X5	L-W 3		
TSL-SW 32-12	SS M8X1.25X6	L-W 4		
TSL-SW 32-16	SS M8X1.25X6	L-W 4		
TSL-SW 32-20	SS M8X1.25X6	L-W 4		

Reaming Tools



XR...-3B/5B-SO



Head changeable reamer holders for small diameter blind hole



• Cylindrical shank

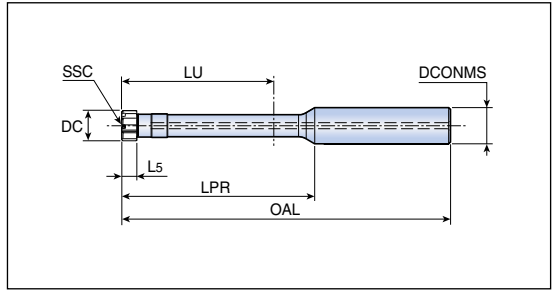

Designation	DC	SSC	Dimension (mm)					Overhang
			DCONMS	L5	OAL	LU	LPR	
XR-D08-3B-10S0	8.000-8.999	8	10	4.0	81.0	28.0	36.0	3XD
D09-3B-10S0	9.000-9.999	9	10	4.5	85.5	31.5	40.5	
D10-3B-12S0	10.000-10.999	10	12	5.0	89.0	35.0	44.0	
D11-3B-12S0	11.000-11.999	11	12	5.5	92.5	38.5	47.5	
D12-3B-12S0	12.000-12.999	12	12	6.0	96.0	42.0	51.0	
XR-D08-5B-10S0	8.000-8.999	8	10	4.0	97.0	44.0	52.0	5XD
D09-5B-10S0	9.000-9.999	9	10	4.5	103.5	49.5	58.5	
D10-5B-12S0	10.000-10.999	10	12	5.0	109.0	55.0	64.0	
D11-5B-12S0	11.000-11.999	11	12	5.5	114.5	60.5	69.5	
D12-5B-12S0	12.000-12.999	12	12	6.0	120.0	66.0	75.0	

- ▶ SSC: Seat size code
- ▶ Matched with XR...-AS reamer heads
- ▶ Reamer head is sold separately from reamer holder

Spare parts

Designation	Clamping key	Key handle
XR-D08	W XR D08-KEY	SW6-T-SH
XR-D09	W XR D08-KEY	SW6-T-SH
XR-D10	W XR D10-KEY	SW6-T-SH
XR-D11	W XR D10-KEY	SW6-T-SH
XR-D12	W XR D12-KEY	SW6-T-SH



▶ Clamping key & clamping screw are included

XR...-3T/5T-S0



Head changeable reamer holders for small diameter through hole



• Cylindrical shank

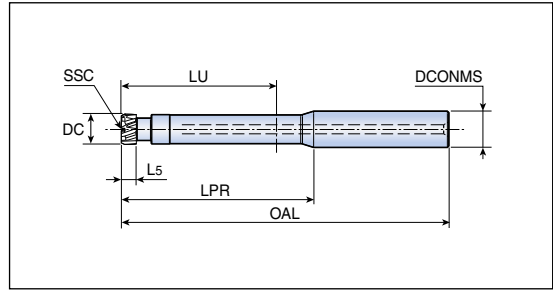

Designation	DC	SSC	Dimension (mm)					Overhang
			DCONMS	L5	OAL	LU	LPR	
XR-D08-3T-10S0	8.000-8.999	8	10	4.0	81.0	28.0	36.0	3XD
D09-3T-10S0	9.000-9.999	9	10	4.5	85.5	31.5	40.5	
D10-3T-12S0	10.000-10.999	10	12	5.0	89.0	35.0	44.0	
D11-3T-12S0	11.000-11.999	11	12	5.5	92.5	38.5	47.5	
D12-3T-12S0	12.000-12.999	12	12	6.0	95.0	42.0	50.0	
XR-D08-5T-10S0	8.000-8.999	8	10	4.0	97.0	44.0	52.0	5XD
D09-5T-10S0	9.000-9.999	9	10	4.5	103.5	49.5	58.5	
D10-5T-12S0	10.000-10.999	10	12	5.0	109.0	55.0	64.0	
D11-5T-12S0	11.000-11.999	11	12	5.5	114.5	60.5	69.5	
D12-5T-12S0	12.000-12.999	12	12	6.0	119.0	66.0	74.0	

- ▶ SSC: Seat size code
- ▶ Matched with XR...-BL reamer heads
- ▶ Reamer head is sold separately from reamer holder

Spare parts

Designation	Clamping key	Key handle
XR-D08	W XR D08-KEY	SW6-T-SH
XR-D09	W XR D08-KEY	SW6-T-SH
XR-D10	W XR D10-KEY	SW6-T-SH
XR-D11	W XR D10-KEY	SW6-T-SH
XR-D12	W XR D12-KEY	SW6-T-SH



▶ Clamping key & clamping screw are included

XR...-AS



Head changeable reamer head

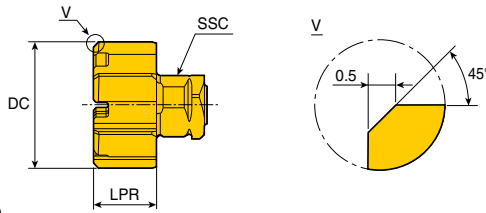

- Straight flute for blind hole
- For H7 hole tolerance

Head	Designation	Dimension (mm)		NOF	SSC	Flute type	Edge type	Grade TT9030
		DC	LPR					
	XR-08.000-AS	8.000	4.0	6	8	S	A	●
	09.000-AS	9.000	4.5	6	9	S	A	●
	10.000-AS	10.000	5.0	6	10	S	A	●
	11.000-AS	11.000	5.5	6	11	S	A	●
	12.000-AS	12.000	6.0	6.0	6	12	S	A



- ▶ NOF: Number of flutes
- ▶ SSC: Seat size code

●: Standard items

XR...-BL



Head changeable reamer head

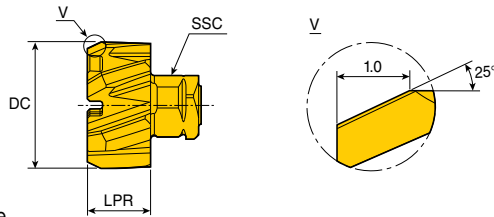

- Helical flute for through hole
- For H7 hole tolerance

Head	Designation	Dimension (mm)		NOF	SSC	Flute type	Edge type	Grade TT9030
		DC	LPR					
	XR-08.000-BL	8.000	4.0	6	8	L	B	●
	09.000-BL	9.000	4.5	6	9	L	B	●
	10.000-BL	10.000	5.0	6	10	L	B	●
	11.000-BL	11.000	5.5	6	11	L	B	●
	12.000-BL	12.000	6.0	6.0	6	12	L	B



- ▶ NOF: Number of flutes
- ▶ SSC: Seat size code

●: Standard items

Head changeable reamer holders



- Cylindrical shank

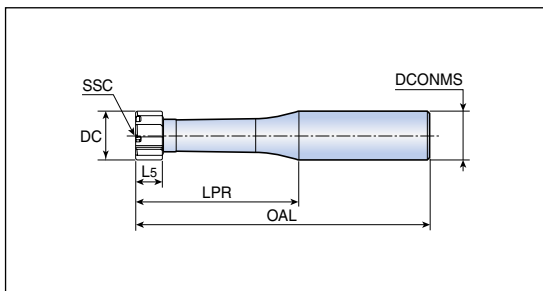

Designation	DC	SSC	Dimension (mm)				Overhang
			DCONMS	L5	OAL	LPR	
TM-3B5-16TO	11.501-13.500	B5	16	9.3	97.8	49.8	3XD
3B6-16TO	13.501-16.000	B6	16	9.4	105.4	57.4	
3B7-20TO	16.000-20.000	B7	20	10.6	120.6	70.6	
3B8-20TO	20.001-25.400	B8	20	12.8	137.8	87.8	
3B9-32TO	25.401-32.000	B9	32	12.8	167.1	107.1	
5B5-16TO	11.501-13.500	B5	16	9.3	125.0	77.0	5XD
5B6-16TO	13.501-16.000	B6	16	9.4	137.4	89.4	
5B7-20TO	16.000-20.000	B7	20	10.6	160.6	110.6	
5B8-20TO	20.001-25.400	B8	20	12.8	187.8	137.8	
5B9-32TO	25.401-32.000	B9	32	12.8	231.1	171.1	
8B5-16TO	11.501-13.500	B5	16	9.3	165.5	117.5	8XD
8B6-16TO	13.501-16.000	B6	16	9.4	185.4	137.4	
8B7-20TO	16.000-20.000	B7	20	10.6	220.6	170.6	
8B8-20TO	20.001-25.400	B8	20	12.8	262.8	212.8	
8B9-32TO	25.401-32.000	B9	32	12.8	327.1	267.1	

- ▶ SSC: Seat size code
- ▶ Reamer head is sold separately from reamer holder

Spare parts

Designation	Clamping screw	Clamping key
TM...B5-16TO	TM-B5-SCR	TM-B5-KEY
TM...B6-16TO	TM-B6-SCR	TM-B6-KEY
TM...B7-20TO	TM-B7-SCR	TM-B7-KEY
TM...B8-20TO	TM-B8-SCR	TM-B8-KEY
TM...B9-32TO	TM-B9-SCR	TM-B9-KEY

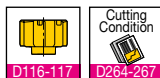

- ▶ Clamping key & clamping screw are included

Head changeable reamer heads

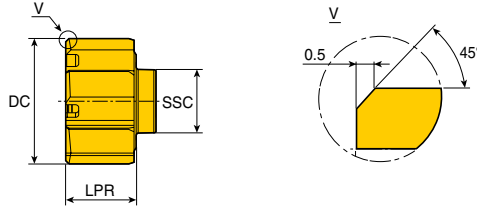

- Straight flute for blind hole
- For H7 hole tolerance

Head	Designation	Dimension (mm)		NOF	SSC	Flute type	Edge type	Grade TT9030	
		DC	LPR						
	TM- 11.501-AS-B5	11.501	9.5	6	B5	S	A	●	
	12.000-AS-B5	12.000	9.5	6	B5	S	A	●	
	13.000-AS-B5	13.000	9.5	6	B5	S	A	●	
	13.500-AS-B5	13.500	9.5	6	B5	S	A	●	
	13.501-AS-B6	13.501	9.5	6	B6	S	A	●	
	14.000-AS-B6	14.000	9.5	6	B6	S	A	●	
	15.000-AS-B6	15.000	9.5	6	B6	S	A	●	
	16.000-AS-B6	16.000	9.5	6	B6	S	A	●	
	16.001-AS-B7	16.001	10.7	6	B7	S	A	●	
	17.000-AS-B7	17.000	10.7	6	B7	S	A	●	
	18.000-AS-B7	18.000	10.7	6	B7	S	A	●	
	19.000-AS-B7	19.000	10.7	6	B7	S	A	●	
	20.000-AS-B7	20.000	10.7	6	B7	S	A	●	
	20.001-AS-B8	20.001	12.9	8	B8	S	A	●	
	21.000-AS-B8	21.000	12.9	8	B8	S	A	●	
	22.000-AS-B8	22.000	12.9	8	B8	S	A	●	
	23.000-AS-B8	23.000	12.9	8	B8	S	A	●	
	24.000-AS-B8	24.000	12.9	8	B8	S	A	●	
	25.000-AS-B8	25.000	12.9	8	B8	S	A	●	
	26.000-AS-B9	26.000	12.9	8	B9	S	A	●	
	27.000-AS-B9	27.000	12.9	8	B9	S	A	●	
	28.000-AS-B9	28.000	12.9	8	B9	S	A	●	
	29.000-AS-B9	29.000	12.9	8	B9	S	A	●	
	30.000-AS-B9	30.000	12.9	8	B9	S	A	●	
	31.000-AS-B9	31.000	12.9	8	B9	S	A	●	
	32.000-AS-B9	32.000	12.9	8	B9	S	A	●	

▶ NOF: Number of flutes
 ▶ SSC: Seat size code

● Standard items

Head changeable reamer heads

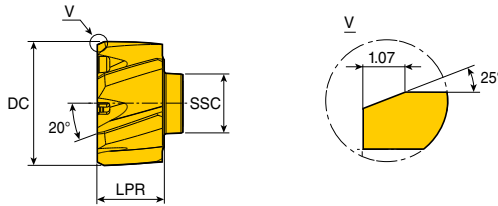

- Helical flute for through hole
- For H7 hole tolerance

Head	Designation	Dimension (mm)		NOF	SSC	Flute type	Edge type	Grade TT9030	
		DC	LPR						
	TM - 11.501-BL-B5	11.501	9.5	6	B5	L	B	•	
	12.000-BL-B5	12.000	9.5	6	B5	L	B	•	
	13.000-BL-B5	13.000	9.5	6	B5	L	B	•	
	13.500-BL-B5	13.500	9.5	6	B5	L	B	•	
	13.501-BL-B6	13.501	9.5	6	B6	L	B	•	
	14.000-BL-B6	14.000	9.5	6	B6	L	B	•	
	15.000-BL-B6	15.000	9.5	6	B6	L	B	•	
	16.000-BL-B6	16.000	9.5	6	B6	L	B	•	
	16.001-BL-B7	16.001	10.7	6	B7	L	B	•	
	17.000-BL-B7	17.000	10.7	6	B7	L	B	•	
	18.000-BL-B7	18.000	10.7	6	B7	L	B	•	
	19.000-BL-B7	19.000	10.7	6	B7	L	B	•	
	20.000-BL-B7	20.000	10.7	6	B7	L	B	•	
	20.001-BL-B8	20.001	12.9	8	B8	L	B	•	
	21.000-BL-B8	21.000	12.9	8	B8	L	B	•	
	22.000-BL-B8	22.000	12.9	8	B8	L	B	•	
	23.000-BL-B8	23.000	12.9	8	B8	L	B	•	
	24.000-BL-B8	24.000	12.9	8	B8	L	B	•	
	25.000-BL-B8	25.000	12.9	8	B8	L	B	•	
	26.000-BL-B9	26.000	12.9	8	B9	L	B	•	
	27.000-BL-B9	27.000	12.9	8	B9	L	B	•	
	28.000-BL-B9	28.000	12.9	8	B9	L	B	•	
	29.000-BL-B9	29.000	12.9	8	B9	L	B	•	
	30.000-BL-B9	30.000	12.9	8	B9	L	B	•	
	31.000-BL-B9	31.000	12.9	8	B9	L	B	•	
	32.000-BL-B9	32.000	12.9	8	B9	L	B	•	



- ▶ NOF: Number of flutes
- ▶ SSC: Seat size code

•: Standard items

Deep Drilling Tools



DRILL-RUSH head-changeable and modular shank gundrill holders



- Drilling depth: 16-20x diameter

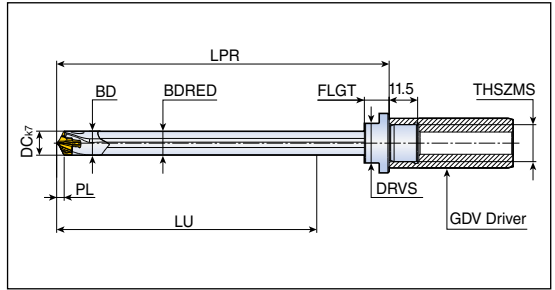

Designation	Dimension (mm)										Clamping Key
	DC	LU	LPR	PL	THSZMS	BD	BDRED	FLGT	DRVS	SSC	
TCDGN 100X200-MF16X1	10.0-10.4	200	274	2.33	MF16X1	9.7	9.6	10	16	10	K TCD D100-D199
100X400-MF16X1	10.0-10.4	400	474	2.33	MF16X1	9.7	9.6	10	16	10	
110X200-MF16X1	11.0-11.4	200	275	2.50	MF16X1	10.7	10.6	10	16	11	
110X400-MF16X1	11.0-11.4	400	474	2.50	MF16X1	10.7	10.6	10	16	11	
120X200-MF16X1	12.0-12.4	200	275	2.67	MF16X1	11.7	11.6	10	16	12	
120X400-MF16X1	12.0-12.4	400	475	2.67	MF16X1	11.7	11.6	10	16	12	
130X200-MF16X1	13.0-13.4	200	276	2.85	MF16X1	12.7	12.6	12	16	13	
130X400-MF16X1	13.0-13.4	400	476	2.85	MF16X1	12.7	12.6	12	16	13	
140X250-MF16X1	14.0-14.4	250	326	3.02	MF16X1	13.7	13.6	12	16	14	
140X400-MF16X1	14.0-14.4	400	476	3.02	MF16X1	13.7	13.6	12	16	14	
145X250-MF16X1	14.5-14.9	250	326	3.02	MF16X1	14.2	14.1	12	18	14	
145X400-MF16X1	14.5-14.9	400	476	3.02	MF16X1	14.2	14.1	12	18	14	
150X400-MF16X1	15.0-15.9	400	484	3.19	MF16X1	14.7	14.6	12	18	15	
160X400-MF20X1	16.0-16.9	400	484	3.46	MF20X1	15.5	15.4	12	18	16	
170X400-MF20X1	17.0-17.9	400	485	3.63	MF20X1	16.5	16.4	12	22	17	
180X400-MF20X1	18.0-18.9	400	486	3.81	MF20X1	17.5	17.4	12	22	18	
190X400-MF20X1	19.0-19.9	400	486	3.98	MF20X1	18.5	18.4	12	22	19	
200X400-MF20X1	20.0-20.9	400	487	4.15	MF20X1	19.5	19.4	12	22	20	K TCD D200-D269
210X400-MF20X1	21.0-21.9	400	503	4.32	MF20X1	20.5	20.4	21	28	21	
220X400-MF20X1	22.0-22.9	400	504	4.50	MF20X1	21.5	21.4	21	28	22	
230X400-MF20X1	23.0-23.9	400	504	4.67	MF20X1	22.5	22.4	21	28	23	
240X400-MF20X1	24.0-24.9	400	505	4.84	MF20X1	23.5	23.4	21	28	24	
250X400-MF20X1	25.0-25.9	400	506	5.01	MF20X1	24.5	24.4	21	28	25	



- ▶ OAL: LPR+11.5
- ▶ Driver is sold separately from drill holder
- ▶ SSC: Seat size code

Standard gundrill holders



- Drilling depth: 10-25x diameter

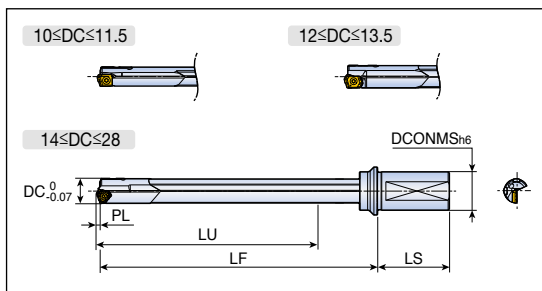

Designation	Dimension (mm)						
	DC	LU	LF	LS	DCONMS	PL	L/D
TRGD 16.00xM25-10	16.0	172	209	56	25	2.2	10
16.50xM25-10	16.5	172	209	56	25	2.2	10
17.00xM25-10	17.0	182	220	56	25	2.2	10
18.00xM25-10	18.0	193	232	56	25	3.0	10
19.00xM25-10	19.0	203	243	56	25	3.0	10
20.00xM32-10	20.0	213	255	60	32	3.2	10
29.00xFM40-10	29.0	294.6	360	69	40	4.57	10
30.00xFM40-10	30.0	314.6	383	69	40	4.57	10
31.00xFM40-10	31.0	314.6	383	69	40	4.57	10
32.00xFM40-10	33.0	324.6	395	69	40	4.57	10
12.00XM20-15	12.0	196.8	225	50	20	1.8	15
12.50XM20-15	12.5	196.8	226	50	20	1.8	15
13.00XM25-15	13.0	211.8	245	56	25	1.8	15
13.50XM25-15	13.5	211.8	245	56	25	1.8	15
14.00xM25-15	14.0	227	261	56	25	2.0	15
14.50xM25-15	14.5	227	262	56	25	2.0	15
15.00xM25-15	15.0	242	278	56	25	2.0	15
16.00xM25-15	16.0	257	294	56	25	2.2	15
16.50xM25-15	16.5	257	294	56	25	2.2	15
17.00xM25-15	17.0	272	310	56	25	2.2	15
17.50xM25-15	17.5	272	310	56	25	2.2	15
18.00xM25-15	18.0	288	327	56	25	3.0	15
18.50xM25-15	18.5	288	327	56	25	3.0	15
19.00xM25-15	19.0	303	343	56	25	3.0	15
19.50xM25-15	19.5	303	343	56	25	3.0	15
20.00xM32-15	20.0	318	360	60	32	3.2	15
21.00xM32-15	21.0	333	376	60	32	3.2	15
22.00xM32-15	22.0	348	393	60	32	3.4	15
23.00xM32-15	23.0	363	409	60	32	3.4	15
24.00xM32-15	24.0	378	426	60	32	3.4	15
25.00xM32-15	25.0	394	442	60	32	3.6	15
26.00xM40-15	26.0	409	449	70	40	3.6	15
27.00xM40-15	27.0	424	465	70	40	3.6	15
28.00xM40-15	28.0	424	467	70	40	3.6	15



► Guide pad is sold separately from drill body

► Available upon request

D129

D260

Standard gundrill holders



• Drilling depth: 10-25x diameter

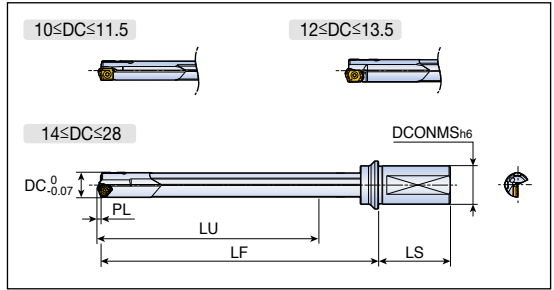

Designation	Dimension (mm)						
	DC	LU	LF	LS	DCONMS	PL	L/D
TRGD 12.00XM20-20	12.0	261.8	290	50	20	1.8	20
12.50XM20-20	12.5	261.8	291	50	20	1.8	20
13.00XM25-20	13.0	281.8	315	56	25	1.8	20
13.50XM25-20	13.5	281.8	315	56	25	1.8	20
14.00xM25-20	14.0	302	336	56	25	2.0	20
14.50xM25-20	14.5	302	337	56	25	2.0	20
15.00xM25-20	15.0	322	358	56	25	2.0	20
29.00xFM40-20	29.0	584.6	650	69	40	4.57	20
30.00xFM40-20	30.0	624.6	693	69	40	4.57	20
31.00xFM40-20	31.0	624.6	693	69	40	4.57	20
32.00xFM40-20	32.0	644.6	715	69	40	4.57	20
10.00XM20-25	10.0	264.5	289.5	50	20	1.8	25
11.00XM20-25	11.0	301.7	329	50	20	1.8	25
11.50XM20-25	11.5	301.7	329	50	20	1.8	25
12.00XM20-25	12.0	326.8	355	50	20	1.8	25
12.50XM20-25	12.5	326.8	356	50	20	1.8	25
13.00XM25-25	13.0	351.8	385	56	25	1.8	25
13.50XM25-25	13.5	351.8	385	56	25	1.8	25
14.00xM25-25	14.0	377	411	56	25	2.0	25
14.50xM25-25	14.5	377	412	56	25	2.0	25
15.00xM25-25	15.0	402	438	56	25	2.0	25
16.00xM25-25	16.0	427	464	56	25	2.2	25
16.50xM25-25	16.5	427	464	56	25	2.2	25
17.00xM25-25	17.0	452	490	56	25	2.2	25
17.50xM25-25	17.5	452	490	56	25	2.2	25
18.00xM25-25	18.0	478	517	56	25	3.0	25
18.50xM25-25	18.5	478	517	56	25	3.0	25
19.00xM25-25	19.0	503	543	56	25	3.0	25
19.50xM25-25	19.5	503	543	56	25	3.0	25
20.00xM32-25	20.0	528	570	60	32	3.2	25
21.00xM32-25	21.0	553	596	60	32	3.2	25
22.00xM32-25	22.0	578	623	60	32	3.4	25
23.00xM32-25	23.0	603	649	60	32	3.4	25
24.00xM32-25	24.0	628	676	60	32	3.4	25
25.00xM32-25	25.0	654	702	60	32	3.6	25

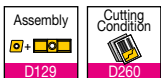

▶ Guide pad is sold separately from drill body

▶ Available upon request

Standard gundrill holders



- Drilling depth: 10-25x diameter

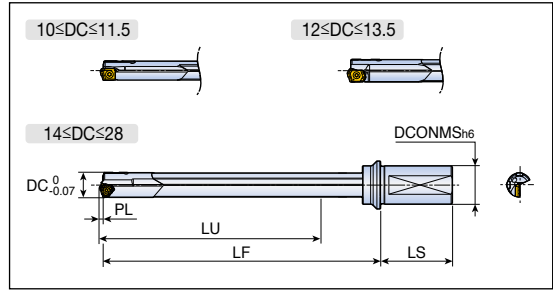

Designation	Dimension (mm)						
	DC	LU	LF	LS	DCONMS	PL	L/D
TRGD 26.00xM40-25	26.0	679	729	70	40	3.6	25
27.00xM40-25	27.0	704	755	70	40	3.6	25
28.00xM40-25	28.0	704	757	70	40	3.6	25

Insert & guide pad

Tool dia. (mm)	Insert			Guide pad		
	Insert	Screw	Wrench	Guide pad	Screw	Wrench
10.00-10.99	ZSGT 060204R-RS	SR-M2.5X0.35L3.8	T-7F	PAD-GP04-16-045-DC-SB	CSTB-2	T-6F
11.00-11.99	LOGT 060204R-RS	SR 10503833L040	T-7F	PAD-GP04-16-050-DC-SB	CSTB-2	T-6F
12.00-13.99				PAD-GP04-16-055-DC-SB		
12.00-13.99				PAD-GP04-16-055-DC-SC		
14.00-15.99	TOGT 070304 RS TT9030	CSTB2.5S*	T-8F	PAD-GP05-18-060-DC-SB PAD-GP05-18-060-DC-SC	SR 34-508	T-7F
16.00-18.00	TOGT 080305 RS TT9030	CSTB2.5S*	T-8F	PAD-GP05-18-075-DC-SB PAD-GP05-18-075-DC-SC	SR 34-508	T-7F
18.01-20.00	TOGT 090305 RS TT9030	CSTB2.5S*	T-8F	PAD-GP06-20-085-DC-SB PAD-GP06-20-085-DC-SC	SR 34-508	T-7F
20.01-21.00	TOGT 100305 RS TT9030	CSTB3S*	T-9F			
21.01-21.99	TOGT 100305 RS TT9030	CSTB3S*	T-9F	PAD-GP06-20-100-DC-SB PAD-GP06-20-100-DC-SC	SR 34-508	T-7F
22.00-25.00	TOGT 110405 RS TT9030	SR14-571/S	T-10/5			
25.01-28.00	TOGT 120405 RS TT9030	CSTB4S	T-15F	PAD-GP06-20-120-DC-SB PAD-GP06-20-120-DC-SC	SR 34-508	T-7F
28.01-29.99	TOGT 130408 RS	SR 16-212/L10	T-20/5	PAD-GP06-20-120-DC-SB PAD-GP06-20-120-DC-SC	SR 34-508	T-7F
30.00-32.00	TOGT 130408 RS	SR 16-212/L10	T-20/5	PAD-GP07-20-120-DC-SB PAD-GP07-20-120-DC-SC	CSTB-3S	T-9F



- ▶ Guide pad with "SB" is the first choice in general purpose machining
- "SC" is an excellent toughness grade used with water-soluble coolant
- ▶ Inserts and guide pads must be ordered separately

Standard gundrill holders



- Drilling depth: 10-15x diameter

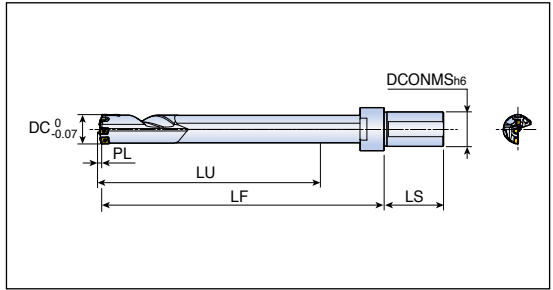

Designation	Dimension (mm)						
	DC	LU	LF	LS	DCONMS	PL	L/D
TRGD3 29.00xFM40-10	29.0	293	360	69	40	2.6	10
30.00xFM40-10	30.0	313	383	69	40	2.9	10
31.00xFM40-10	31.0	313	383	69	40	2.9	10
32.00xFM40-10	32.0	323	395	69	40	3.0	10
33.00xFM40-10	33.0	333	406	69	40	3.1	10
34.00xFM40-10	34.0	343	418	69	40	3.0	10
35.00xFM40-10	35.0	353	428	69	40	3.1	10
36.00xFM40-10	36.0	363	441	69	40	3.1	10
29.00xFM40-15	29.0	438	505	69	40	2.6	15
30.00xFM40-15	30.0	468	538	69	40	2.9	15
31.00xFM40-15	31.0	468	538	69	40	2.9	15
32.00xFM40-15	32.0	483	555	69	40	3.0	15
33.00xFM40-15	33.0	498	571	69	40	3.1	15
34.00xFM40-15	34.0	513	588	69	40	3.0	15
35.00xFM40-15	35.0	528	603	69	40	3.1	15
36.00xFM40-15	36.0	543	621	69	40	3.1	15

- ▶ Guide pad is sold separately from drill body.
- ▶ Supply up to 40.0mm drill diameter

▶ Available upon request

Insert & guide pad

Parts	Diameter (mm)				
	29.0-29.99	30.0-33.0	33.01-35.0	35.01-36.0	
Insert	Peripheral insert	NPHT 060304R-G-P	NPHT 080404R-G-P	NPHT 080404R-G-P	NPHT 080404R-G-P
	Screw	CSTB2.2	CSTB2.5	CSTB2.5	CSTB2.5
	Wrench	T-7F	T-8F	T-8F	T-8F
	Inner insert	NPMT 060304R-G-I	NPMT 070404R-G-I	NPMT 070404R-G-I	NPMT 070404R-G-I
	Screw	CSTB2.2	CSTB2.5	CSTB2.5	CSTB2.5
	Wrench	T-7F	T-8F	T-8F	T-8F
	Center insert	NPMT 070408L-G-C	NPMT 070408L-G-C	NPMT 070408L-G-C	NPMT 080408L-L-C
	Screw	CSTB2.5	CSTB2.5	CSTB2.5	CSTB2.5
	Wrench	T-8F	T-8F	T-8F	T-8F
Pad	Guide pad	PAD-GP06-20-120-DC-SB	PAD-GP06-20-120-DC-SB	PAD-GP07-20-120-DC-SB	PAD-GP07-20-120-DC-SB
	Screw	PAD-GP06-20-120-DC-SC	PAD-GP06-20-120-DC-SC	PAD-GP07-20-120-DC-SC	PAD-GP07-20-120-DC-SC
	Wrench	SR 34-508	SR 34-508	CSTB3S	CSTB3S



- ▶ Inserts and guide pads must be ordered separately

Standard gundrill holders

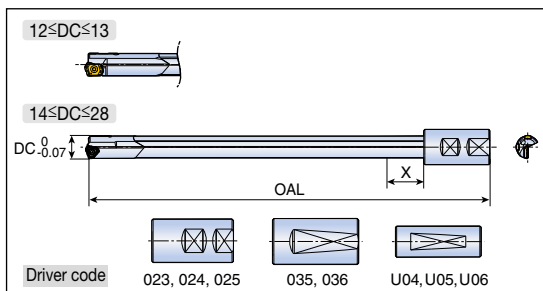

Designation	Driver code	Dimension (mm)		
		DC	OAL	X
TRGDL 12.00X800-XXX	U03 022	12	801.8	18
12.00X800-XXX		12	801.8	18
12.00X1000-XXX		12	1001.8	18
12.00X1000-XXX		12	1001.8	18
12.00X1650-XXX		12	1651.8	18
12.00X1650-XXX		12	1651.8	18
12.70X1219-XXX	U04	12.7	1220.8	19
12.70X1524-XXX		12.7	1525.8	19
13.00X800-XXX	U04 023	13	801.8	20
13.00X800-XXX		13	801.8	20
13.00X1000-XXX		13	1001.8	20
13.00X1000-XXX		13	1001.8	20
13.00X1650-XXX		13	1651.8	20
13.00X1650-XXX		13	1651.8	20
13.49X1219-XXX	U04	13.49	1220.8	20
13.49X1527-XXX		13.49	1528.8	20
14.00x800-XXX	U04 023	14	800	21
14.00x1000-XXX		14	1000	21
14.00x1650-XXX		14	1650	21
14.50x800-XXX		14.5	800	22
14.50x1000-XXX		14.5	1000	22
14.50x1650-XXX		14.5	1650	22
15.00x800-XXX	U04 023 035	15	800	23
15.00x1000-XXX		15	1000	23
15.00x1650-XXX		15	1650	23
16.00x800-XXX		16	800	24
16.00x1000-XXX		16	1000	24
16.00x1500-XXX		16	1500	24
17.00x1000-XXX		17	1000	25
17.00x1500-XXX		17	1500	25
18.00x800-XXX		18	800	27
18.00x1000-XXX		18	1000	27
18.00x1500-XXX		18	1500	27
19.00x800-XXX		19	800	28
19.00x1000-XXX	19	1000	28	
19.00x1500-XXX	19	1500	28	



▶ Guide pad is sold separately from drill body

▶ Available upon request
▶ Select "XXX" driver code

Insert & guide pad

Tool dia. (mm)	Insert			Guide pad		
	Insert	Screw	Wrench	Guide pad	Screw	Wrench
12.00-13.99	LOGT 060204R-RS	SR 10503833L040	T-7F	PAD-GP04-16-055-DC-SB PAD-GP04-16-055-DC-SC	TS 20043/HG-P	T-7F
14.00-15.99	TOGT 070304 RS TT9030	CSTB2.5S	T-8F	PAD-GP05-18-060-DC-SB PAD-GP05-18-060-DC-SC	SR 34-508	T-7F
16.00-18.00	TOGT 080305 RS TT9030	CSTB2.5S	T-8F	PAD-GP05-18-075-DC-SB PAD-GP05-18-075-DC-SC	SR 34-508	T-7F
18.01-20.00	TOGT 090305 RS TT9030	CSTB2.5S*	T-8F	PAD-GP06-20-085-DC-SB PAD-GP06-20-085-DC-SC	SR 34-508	T-7F
20.01-21.00	TOGT 100305 RS TT9030	CSTB3S*	T-9F			
21.01-21.99	TOGT 100305 RS TT9030	CSTB3S*	T-9F	PAD-GP06-20-100-DC-SB PAD-GP06-20-100-DC-SC	SR 34-508	T-7F
22.00-25.00	TOGT 110405 RS TT9030	SR14-571/S	T-10/5			
25.01-28.00	TOGT 120405 RS TT9030	CSTB4S	T-15F	PAD-GP07-20-120-DC-SB PAD-GP07-20-120-DC-SC	SR 34-508	T-7F



- ▶ Guide pad with "SB" is the first choice in general purpose machining
- "SC" is a excellent toughness grade used with water-soluble coolant
- ▶ Inserts and guide pads must be ordered separately

Driver for TRGDL Type

Driver	Driver code	Dimension (mm)	
		LS	DCONMS
	022	50	20.00
	023	56	25.00
	024	60	32.00
	025	70	40.00
	026	80	50.00
	035	56	25.00
	036	60	32.00
	U03	70	19.05
	U04	70	25.40
	U05	70	31.75
	U06	70	38.10

TBTA3 Series



Assembly of TBTA3 series

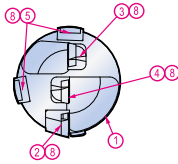
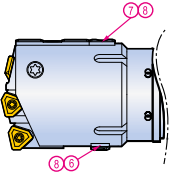

- 1. Head shank
- 2. Outer cartridge
- 3. Inner cartridge
- 4. Center cartridge
- 5. Guide pad
- 6. Sub guide pad
- 7. Guide pad protector
- 8. Lock screw

Parts		Diameter (mm)				
		38.00-39.99	40.00-44.99	45.00-47.99	48.00-51.99	52.00-54.99
Cartridge	Outer	PERC 05R	PERC 402-04	PERC 402-04	PERC 402-04	PERC 402-32
	Adjust screw	AS0003-5	AS0004-8	AS0004-8	AS0004-8	AS0005-10
	Wrench	H1.5	H2	H2	H2	H2.5
	Screw	LS1803RH	LS1803.5RH	LS1803.5RH	LS1803.5RH	LS1805RH
	Wrench	H2	H2.5	H2.5	H2.5	H3
	Inner	CENC 05R	CENC 05R	CENC 05R	CENC 402-04	CENC 402-04
	Screw	CSTB3	CSTB3	CSTB3	CSTB3.5	CSTB3.5
	Wrench	T-9D	T-9D	T-9D	T-15D	T-15D
	Center	CENC 05R	CENC 05R	CENC 402-04	CENC 402-04	CENC 402-04
	Screw	CSTB3	CSTB3	CSTB3.5	CSTB3.5	CSTB3.5
Wrench	T-9D	T-9D	T-15D	T-15D	T-15D	
Insert	Outer	NPMX 080308R-G	TPMX 140308R-G	TPMX 140308R-G	TPMX 140308R-G	TPMX 170408R-G
	Screw	CSTB2.2	CSTB2.5	CSTB2.5	CSTB2.5	CSTB3.5D
	Wrench	T-7D	T-8D	T-8D	T-8D	T-9D
	Inner	NPMX 080308R-G	NPMX 080308R-G	NPMX 080308R-G	TPMX 140308R-G	TPMX 140308R-G
	Screw	CSTB2.2	CSTB2.2	CSTB2.2	CSTB2.5	CSTB2.5
	Wrench	T-7D	T-7D	T-7D	T-8D	T-8D
	Center	NPMX 080308R-G	NPMX 080308R-G	TPMX 140308R-G	TPMX 140308R-G	TPMX 140308R-G
Screw	CSTB2.2	CSTB2.2	CSTB2.5	CSTB2.5	CSTB2.5	
Wrench	T-7D	T-7D	T-8D	T-8D	T-8D	
Pad	Guide pad	PAD-GP08-25-155-DC-SB	PAD-GP08-25-155-DC-SB	PAD-GP10-35-200-DC-SB	PAD-GP10-35-200-DC-SB	PAD-GP10-35-200-DC-SB
	Screw	PAD-GP08-25-155-DC-SC	PAD-GP08-25-155-DC-SC	PAD-GP10-35-200-DC-SC	PAD-GP10-35-200-DC-SC	PAD-GP10-35-200-DC-SC
	Wrench	T-9D	T-9D	T-15D	T-15D	T-15D
	Guide pad protector	PAD-P08	PAD-P08	PAD-P10	PAD-P10	PAD-P10
	Screw	CSTB3S	CSTB3S	CSTB4S	CSTB4S	CSTB4S
	Wrench	T-9D	T-9D	T-15D	T-15D	T-15D
	Sub guide pad	PAD-S08	PAD-S08	PAD-S08	PAD-S08	PAD-S08
	Screw	CSTB3S	CSTB3S	CSTB3S	CSTB3S	CSTB3S
	Wrench	T-9D	T-9D	T-9D	T-9D	T-9D



Assembly of TBTA3 series

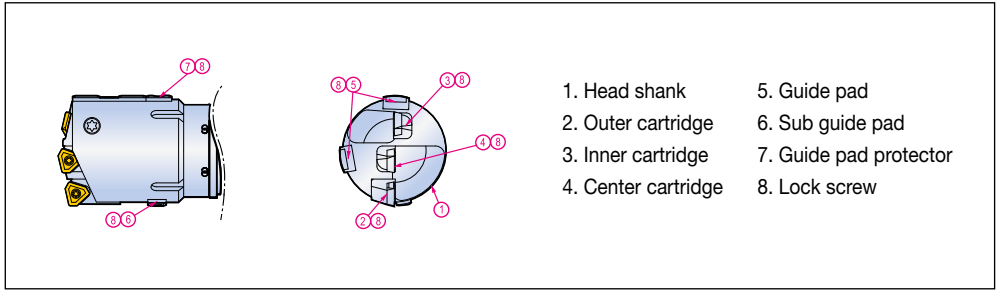

1. Head shank
2. Outer cartridge
3. Inner cartridge
4. Center cartridge
5. Guide pad
6. Sub guide pad
7. Guide pad protector
8. Lock screw

Parts		Diameter (mm)				
		55.00-57.99	58.00-59.99	60.00-63.99	64.00-67.99	68.00-77.99
Cartridge	Outer	PERC 402-32	PERC 402-32	PERC 402-32	PERC 402-43	PERC 402-32
	Adjust screw	AS0005-10	AS0005-10	AS0005-10	AS0005-15	AS0005-10
	Wrench	H2.5	H2.5	H2.5	H2.5	H2.5
	Screw	LS1805RH	LS1805RH	LS1805RH	LS1806RH	LS1805RH
	Wrench	H3	H3	H3	H4	H3
	Inner	CENC 402-04	CENC 402-32	CENC 402-32	CENC 402-32	CENC 402-43
	Screw	CSTB3.5	CSTA5	CSTA5	CSTA5	LS1206
	Wrench	T-15D	T-15D	T-15D	T-15D	H3
	Center	CENC 402-32	CENC 402-32	CENC 402-32	CENC 402-32	CENC 402-43
	Screw	CSTA5	CSTA5	CSTA5	CSTA5	LS1206
Wrench	T-15D	T-15D	T-15D	T-15D	H3	
Insert	Outer	TPMX 170408R-G	TPMX 170408R-G	TPMX 170408R-G	TPMX 240512R-G	TPMX 170408R-G
	Screw	CSTB3.5D	CSTB3.5D	CSTB3.5D	CSTB4M	CSTB3.5D
	Wrench	T-9D	T-9D	T-9D	T-15D	T-9D
	Inner	TPMX 140308R-G	TPMX 170408R-G	TPMX 170408R-G	TPMX 170408R-G	TPMX 240512R-G
	Screw	CSTB2.5	CSTB3.5D	CSTB3.5D	CSTB3.5D	CSTB4M
	Wrench	T-8D	T-9D	T-9D	T-9D	T-15D
	Center	TPMX 170408R-G	TPMX 170408R-G	TPMX 170408R-G	TPMX 170408R-G	TPMX 240512R-G
	Screw	CSTB3.5D	CSTB3.5D	CSTB3.5D	CSTB3.5D	CSTB4M
Wrench	T-9D	T-9D	T-9D	T-9D	T-15D	
Pad	Guide pad	PAD-GP10-35-200-DC-SB	PAD-GP10-35-200-DC-SB	PAD-GP14-40-250-DC-SB	PAD-GP14-40-250-DC-SB	PAD-GP14-40-250-DC-SB
		PAD-GP10-35-200-DC-SC	PAD-GP10-35-200-DC-SC	PAD-GP14-40-250-DC-SC	PAD-GP14-40-250-DC-SC	PAD-GP14-40-250-DC-SC
	Screw	CSTB4S	CSTB4S	CSTA5S	CSTA5S	CSTA5S
	Wrench	T-15D	T-15D	T-15D	T-15D	T-15D
	Guide pad protector	PAD-P10	PAD-P10	PAD-P14	PAD-P14	PAD-P14
	Screw	CSTB4S	CSTB4S	CSTA5S	CSTA5S	CSTA5S
	Wrench	T-15D	T-15D	T-15D	T-15D	T-15D
	Sub guide pad	PAD-S08	PAD-S08	PAD-S08	PAD-S10	PAD-S10
	Screw	CSTB3S	CSTB3S	CSTB3S	CSTB3S	CSTB3S
	Wrench	T-9D	T-9D	T-9D	T-9D	T-9D



TBTA3 Series



Assembly of TBTA3 series

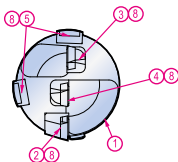
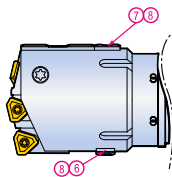

1. Head shank
2. Outer cartridge
3. Inner cartridge
4. Center cartridge
5. Guide pad
6. Sub guide pad
7. Guide pad protector
8. Lock screw

Parts	Diameter (mm)				
	78.00-84.99	85.00-91.99	92.00-98.99	99.00-106.99	
Cartridge	Outer	PERC 402-43	PERC 402-63	PERC 402-43	PERC 402-63
	Adjust screw	AS0005-15	AS0006-15	AS0005-15	AS0006-15
	Wrench	H2.5	H3	H2.5	H3
	Screw	LS1806RH	LS1806RH	LS1806RH	LS1806RH
	Wrench	H4	H4	H4	H4
	Inner	CENC 402-43	CENC 402-43	CENC 402-63	CENC 402-63
	Screw	LS1206	LS1206	LS1206	LS1206
	Wrench	H3	H3	H3	H3
	Center	CENC 402-43	CENC 402-43	CENC 402-63	CENC 402-63
	Screw	LS1206	LS1206	LS1206	LS1206
Insert	Outer	TPMX 240512R-G	TPMX 280716R-G	TPMX 240512R-G	TPMX 280716R-G
	Screw	CSTB4M	CSTB5	CSTB4M	CSTB5
	Wrench	T-15D	T-20D	T-15D	T-20D
	Inner	TPMX 240512R-G	TPMX 240512R-G	TPMX 280716R-G	TPMX 280716R-G
	Screw	CSTB4M	CSTB4M	CSTB5	CSTB5
	Wrench	T-15D	T-15D	T-20D	T-20D
	Center	TPMX 240512R-G	TPMX 240512R-G	TPMX 280716R-G	TPMX 280716R-G
Pad	Screw	CSTB4M	CSTB4M	CSTB5	CSTB5
	Wrench	T-15D	T-15D	T-20D	T-20D
	Guide pad	PAD-GP14-40-250-DC-SB	PAD-GP14-40-250-DC-SB	PAD-GP14-40-250-DC-SB	PAD-GP18-40-300-DC-SB
	Screw	PAD-GP14-40-250-DC-SC	PAD-GP14-40-250-DC-SC	PAD-GP14-40-250-DC-SC	PAD-GP18-40-300-DC-SC
	Wrench	CSTA5S	CSTA5S	CSTA5S	LS1206S
	Wrench	T-15D	T-15D	T-15D	H3
	Guide pad protector	PAD-P14	PAD-P14	PAD-P14	PAD-P18
	Screw	CSTA5S	CSTA5S	CSTA5SS	LS1206S
	Wrench	T-15D	T-15D	T-15D	H3
	Sub guide pad	PAD-S10	PAD-S10	PAD-S10	PAD-S14
Screw	CSTB3S	CSTB3S	CSTB3S	CSTA5S	
Wrench	T-9D	T-9D	T-9D	T-15D	



TBTA5...SE4



Single tube system



- Outer four start thread

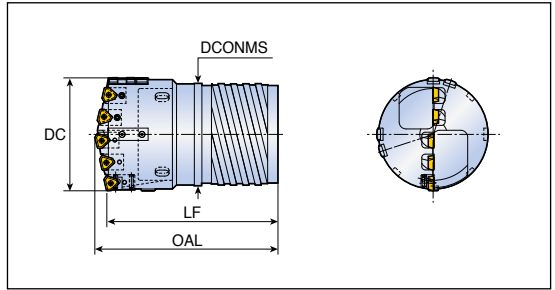

Designation	DC	Dimension (mm)			Tube	
		LF	OAL	DCONMS	Part	Diameter (mm)
TBTA5- xxx.xxSE4-094	107.00-111.99	180	197	89	BTSI 094	94
xxx.xxSE4-106	112.00-123.99	205	221	101	BTSI 106	106
xxx.xxSE4-118	124.00-135.99	205	222	113	BTSI 118	118
xxx.xxSE4-130	136.00-147.99	205	223	125	BTSI 130	130
xxx.xxSE4-142	148.00-159.99	225	245	137	BTSI 142	142
xxx.xxSE4-154	160.00-168.99	225	246	149	BTSI 154	154

TBTA5...SI1



Single tube system



- Inner single start thread

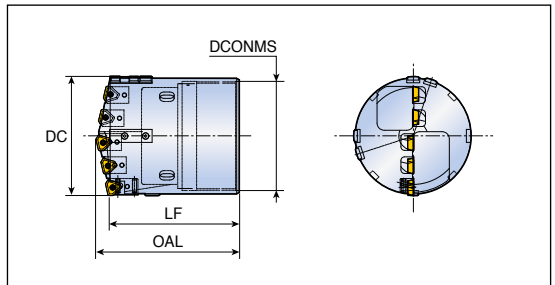

Designation	DC	Dimension (mm)			Tube	
		LF	OAL	DCONMS	Part	Diameter (mm)
TBTA5- xxx.xxSI1-094	107.00-110.99	150	164	90	BTSE 094	94
xxx.xxSI1-106	111.00-122.99	150	165	102	BTSE 106	106
xxx.xxSI1-118	123.00-134.99	150	167	114	BTSE 118	118
xxx.xxSI1-130	135.00-148.99	150	168	126	BTSE 130	130
xxx.xxSI1-142	149.00-161.99	150	170	139	BTSE 142	142
xxx.xxSI1-154	162.00-168.99	190	211	151	BTSE 154	154

Assembly D142	Tube D171, D173	Cutting Condition D252
------------------	--------------------	---------------------------

Assembly of TBTA5 series

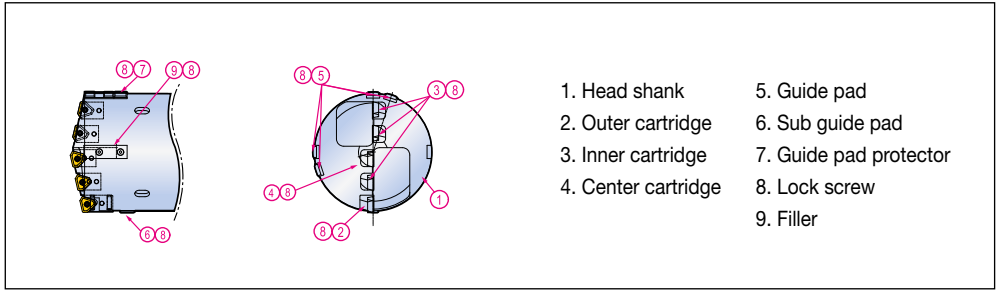

Parts		Diameter (mm)			
		107.00-117.99	118.00-135.99	136.00-144.99	145.00-150.99
Cartridge	Outer	PERC 402-43	PERC 402-43	PERC 402-43	PERC 402-43
	Adjust screw	AS0005-15	AS0005-15	AS0005-15	AS0005-15
	Wrench	H2.5	H2.5	H2.5	H2.5
	Screw	LS1806RH	LS1806RH	LS1806RH	LS1806RH
	Wrench	H4	H4	H4	H4
	Inner	CENC 402-32	CENC 402-43	CENC 402-43	CENC 402-43
	Screw	CSTA5	LS1206	LS1206	LS1206
	Wrench	T-15D	H3	H3	H3
	Center	CENC 402-43	CENC 402-43	CENC 402-63	CENC 402-63
	Screw	LS1206	LS1206	LS1206	LS1206
Wrench	H3	H3	H3	H3	
Insert	Outer	TPMX 240512R-G	TPMX 240512R-G	TPMX 240512R-G	TPMX 240512R-G
	Screw	CSTB4M	CSTB4M	CSTB4M	CSTB4M
	Wrench	T-15D	T-15D	T-15D	T-15D
	Inner	TPMX 170408R-G	TPMX 240512R-G	TPMX 240512R-G	TPMX 240512R-G
	Screw	CSTB3.5D	CSTB4M	CSTB4M	CSTB4M
	Wrench	T-9D	T-15D	T-15D	T-15D
	Center	TPMX 240512R-G	TPMX 240512R-G	TPMX 280716R-G	TPMX 280716R-G
Screw	CSTB4M	CSTB4M	CSTB5	CSTB5	
Wrench	T-15D	T-15D	T-20D	T-20D	
Pad	Guide pad	PAD-GP18-40-300-DC-SB PAD-GP18-40-300-DC-SC	PAD-GP18-40-300-DC-SB PAD-GP18-40-300-DC-SC	PAD-GP18-40-300-DC-SB PAD-GP18-40-300-DC-SC	PAD-GP18-40-300-DC-SB PAD-GP18-40-300-DC-SC
	Screw	LS1206S	LS1206S	LS1206S	LS1206S
	Wrench	H3	H3	H3	H3
	Guide pad protector	PAD-P18	PAD-P18	PAD-P18	PAD-P18
	Screw	LS1206S	LS1206S	LS1206S	LS1206S
	Wrench	H3	H3	H3	H3
	Sub guide pad	PAD-S14	PAD-S14	PAD-S14	PAD-S14
	Screw	CSTA5S	CSTA5S	CSTA5S	CSTA5S
	Wrench	T-15D	T-15D	T-15D	T-15D



TBTA5 Series



Assembly of TBTA5 series

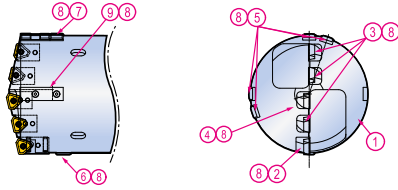

1. Head shank
2. Outer cartridge
3. Inner cartridge
4. Center cartridge
5. Guide pad
6. Sub guide pad
7. Guide pad protector
8. Lock screw
9. Filler

Parts	Diameter (mm)			
	151.00-156.99	157.00-162.99	163.00-168.99	
Cartridge	Outer	PERC 402-63	PERC 402-63	PERC 402-63
	Adjust screw	AS0006-15	AS0006-15	AS0006-15
	Wrench	H3	H3	H3
	Screw	LS1806RH	LS1806RH	LS1806RH
	Wrench	H4	H4	H4
	Inner	CENC 402-43	CENC 402-43	CENC 402-63
	Screw	LS1206	LS1206	LS1206
	Wrench	H3L	H3L	H3L
	Center	CENC 402-63	CENC 402-63	CENC 402-63
	Screw	LS1206S	LS1206S	LS1206S
Insert	Outer	TPMX 280716R-G	TPMX 280716R-G	TPMX 280716R-G
	Screw	CSTB5	CSTB5	CSTB5
	Wrench	T-20D	T-20D	T-20D
	Inner	TPMX 240512R-G	TPMX 240512R-G	TPMX 280716R-G
	Screw	CSTB4M	CSTB4M	CSTB5
	Wrench	T-15D	T-15D	T-20D
	Center	TPMX 280716R-G	TPMX 280716R-G	TPMX 280716R-G
Pad	Screw	CSTB5	CSTB5	CSTB5
	Wrench	T-20D	T-20D	T-20D
	Guide pad	PAD-GP18-40-300-DC-SB	PAD-GP18-40-300-DC-SB	PAD-GP18-40-300-DC-SB
		PAD-GP18-40-300-DC-SC	PAD-GP18-40-300-DC-SC	PAD-GP18-40-300-DC-SC
	Screw	LS1206S	LS1206S	LS1206S
	Wrench	H3	H3	H3L
	Guide pad protector	PAD-P18	PAD-P18	PAD-P18
	Screw	LS1206S	LS1206S	LS1206S
	Wrench	H3	H3	H3
	Sub guide pad	PAD-S14	PAD-S14	PAD-S14
Screw	CSTA5S	CSTA5S	CSTA5S	
Wrench	T-15D	T-15D	T-15D	



TBTA7...SE4



Single tube system

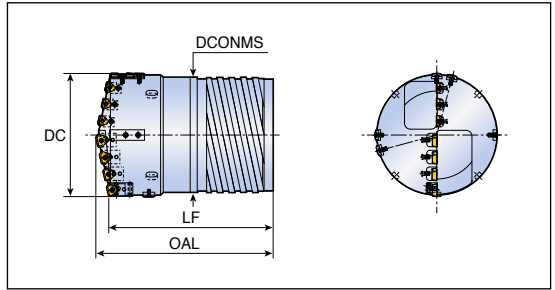

- Outer four start thread
- Double tube system also available on request

Designation	DC	Dimension (mm)			Tube	
		LF	OAL	DCONMS	Part	Diameter (mm)
TBTA7- xxx.xxSE4-154	169.00-171.99	225	246	149	BTSI 154	154
xxx.xxSE4-166	172.00-183.99	225	247	161	BTSI 166	166
xxx.xxSE4-178	184.00-195.99	245	267	173	BTSI 178	178
xxx.xxSE4-190	196.00-207.99	245	270	185	BTSI 190	190
xxx.xxSE4-202	208.00-219.99	245	271	197	BTSI 202	202
xxx.xxSE4-214	220.00-231.99	265	293	208	BTSI 214	214
xxx.xxSE4-226	232.00-232.99	265	293	220	BTSI 226	226

TBTA7...SI1



Single tube system

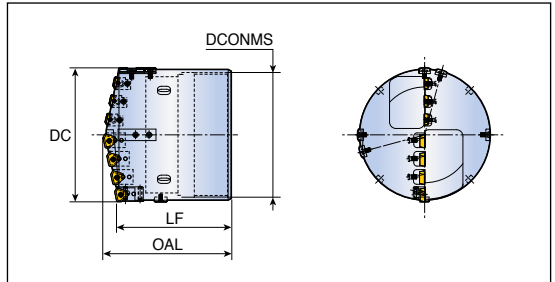

- Inner single start thread

Designation	DC	Dimension (mm)			Tube	
		LF	OAL	DCONMS	Part	Diameter (mm)
TBTA7- xxx.xxSI1-154	169.00-173.99	190	211	151	BTSE 154	154
xxx.xxSI1-166	174.00-185.99	190	213	163	BTSE 166	166
xxx.xxSI1-178	186.00-197.99	190	212	175	BTSE 178	178
xxx.xxSI1-190	198.00-209.99	190	215	187	BTSE 190	190
xxx.xxSI1-202	210.00-221.99	190	217	199	BTSE 202	202
xxx.xxSI1-214	222.00-232.99	190	218	211	BTSE 214	214

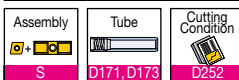

TBTA7 Series



Assembly of TBTA7 series

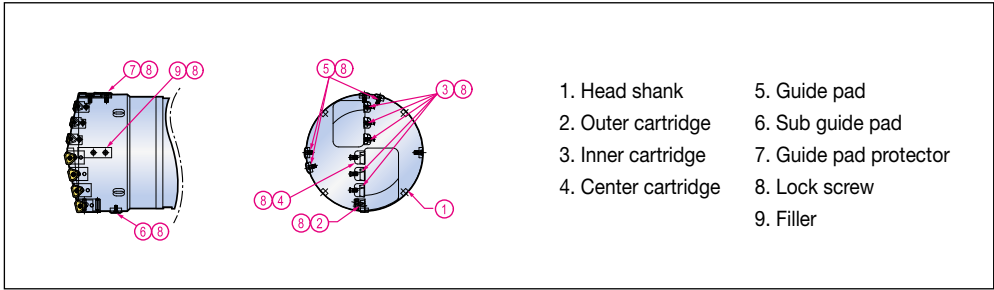

Parts		Diameter (mm)			
		169.00-188.99	189.00-196.99	197.00-202.99	203.00-208.99
Cartridge	Outer	PERC 402-43	PERC 402-43	PERC 402-43	PERC 402-43
	Adjust screw	AS0005-15	AS0005-15	AS0005-15	AS0005-15
	Wrench	H2.5	H2.5	H2.5	H2.5
	Screw	LS1806RH	LS1806RH	LS1806RH	LS1806RH
	Wrench	H4	H4	H4	H4
	Inner	CENC 402-43	CENC 402-43	CENC 402-43	CENC 402-43
	Screw	LS1206	LS1206	LS1206	LS1206
	Wrench	H3L	H3L	H3L	H3L
	Center	CENC 402-43	CENC 402-63	CENC 402-63	CENC 402-63
	Screw	LS1206	LS1206S	LS1206S	LS1206S
Insert	Outer	TPMX 240512R-G	TPMX 240512R-G	TPMX 240512R-G	TPMX 240512R-G
	Screw	CSTB4M	CSTB4M	CSTB4M	CSTB4M
	Wrench	T-15D	T-15D	T-15D	T-15D
	Inner	TPMX 240512R-G	TPMX 240512R-G	TPMX 240512R-G	TPMX 240512R-G
	Screw	CSTB4M	CSTB4M	CSTB4M	CSTB4M
	Wrench	T-15D	T-15D	T-15D	T-15D
	Center	TPMX 240512R-G	TPMX 280716R-G	TPMX 280716R-G	TPMX 280716R-G
Pad	Screw	CSTB4M	CSTB5	CSTB5	CSTB5
	Wrench	T-15D	T-15D	T-15D	T-15D
	Guide pad	PAD-GP18-40-300-DC-SB	PAD-GP18-40-300-DC-SB	PAD-GP18-40-300-DC-SB	PAD-GP18-40-300-DC-SB
		PAD-GP18-40-300-DC-SC	PAD-GP18-40-300-DC-SC	PAD-GP18-40-300-DC-SC	PAD-GP18-40-300-DC-SC
	Screw	LS1206S	LS1206S	LS1206S	LS1206S
	Wrench	H3	H3	H3	H3
	Guide pad protector	PAD-P18	PAD-P18	PAD-P18	PAD-P18
	Screw	LS1206S	LS1206S	LS1206S	LS1206S
	Wrench	H3	H3	H3	H3
	Sub guide pad	PAD-S14	PAD-S14	PAD-S14	PAD-S14
Screw	CSTA5S	CSTA5S	CSTA5S	CSTA5S	
Wrench	T-15D	T-15D	T-15D	T-15D	



TBTA7 Series



Assembly of TBTA7 series

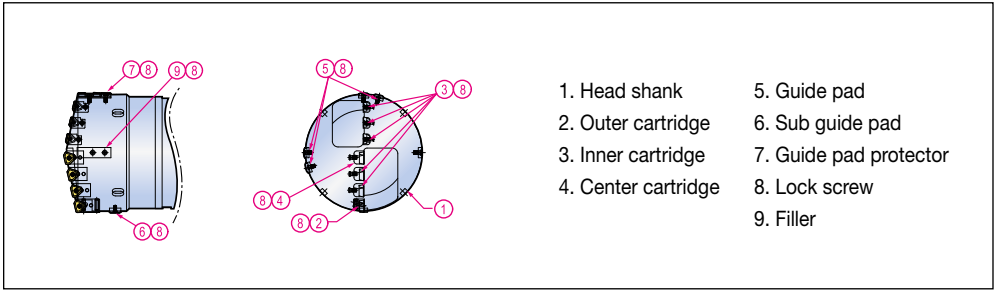

Parts		Diameter (mm)			
		209.00-214.99	215.00-220.99	221.00-226.99	227.00-232.99
Cartridge	Outer	PERC 402-63	PERC 402-63	PERC 402-63	PERC 402-63
	Adjust screw	AS0006-15	AS0006-15	AS0006-15	AS0005-15
	Wrench	H3	H3	H3	H3
	Screw	L1806RH	L1806RH	L1806RH	L1806RH
	Wrench	H4	H4	H4	H4
	Inner	CENC 402-43	CENC 402-43	CENC 402-43	CENC 402-63
	Screw	LS1206	LS1206	LS1206	LS1206
	Wrench	H3L	H3L	H3L	H3L
	Center	CENC 402-63	CENC 402-63	CENC 402-63	CENC 402-63
	Screw	LS1206S	LS1206	LS1206	LS1206S
Insert	Outer	TPMX 280716R-G	TPMX 280716R-G	TPMX 280716R-G	TPMX 280716R-G
	Screw	CSTB5	CSTB5	CSTB5	CSTB5
	Wrench	T-20D	T-20D	T-20D	T-20D
	Inner	TPMX 240512R-G	TPMX 240512R-G	TPMX 240512R-G	TPMX 280716R-G
	Screw	CSTB4M	CSTB4M	CSTB4M	CSTB5
	Wrench	T-15D	T-15D	T-15D	T-15D
	Center	TPMX 280716R-G	TPMX 280716R-G	TPMX 280716R-G	TPMX 280716R-G
Pad	Screw	CSTB5	CSTB5	CSTB5	CSTB5
	Wrench	T-20D	T-20D	T-20D	T-20D
	Guide pad	PAD-GP18-40-300-DC-SB	PAD-GP18-40-300-DC-SB	PAD-GP18-40-300-DC-SB	PAD-GP18-40-300-DC-SB
		PAD-GP18-40-300-DC-SC	PAD-GP18-40-300-DC-SC	PAD-GP18-40-300-DC-SC	PAD-GP18-40-300-DC-SC
	Screw	LS1206S	LS1206S	LS1206S	LS1206S
	Wrench	H3	H3	H3	H3
	Guide pad protector	PAD-P18	PAD-P18	PAD-P18	PAD-P18
	Screw	LS1206S	LS1206S	LS1206S	LS1206S
	Wrench	H3	H3	H3	H3
	Sub guide pad	PAD-S14	PAD-S14	PAD-S14	PAD-S14
Screw	CSTA5S	CSTA5S	CSTA5S	CSTA5S	
Wrench	T-15D	T-15D	T-15D	T-15D	



TBTA9...SE4



Single tube system

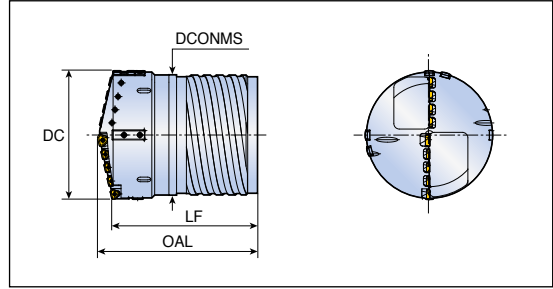

- Outer four start thread

Designation	DC	Dimension (mm)			Tube	
		LF	OAL	DCONMS	Part	Diameter (mm)
TBTA9 - xxx.xxSE4-226	233.00-243.99	265	294	220	BTSI 226	226
xxx.xxSE4-238	244.00-255.99	265	294	232	BTSI 238	238
xxx.xxSE4-250	256.00-267.99	290	322	244	BTSI 250	250
xxx.xxSE4-262	268.00-279.99	290	323	256	BTSI 262	262
xxx.xxSE4-274	280.00-291.99	290	325	268	BTSI 274	274

TBTA9...SI1



Single tube system

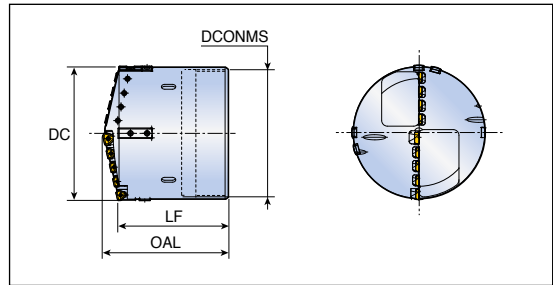

- Inner single start thread

Designation	DC	Dimension (mm)			Tube	
		LF	OAL	DCONMS	Part	Diameter (mm)
TBTA9 - xxx.xxSI1-214	233.00-233.99	190	217	211	BTSE 214	214
xxx.xxSI1-226	234.00-245.99	190	219	223	BTSE 226	226
xxx.xxSI1-238	246.00-257.99	190	221	235	BTSE 238	238
xxx.xxSI1-250	258.00-269.99	210	242	245	BTSE 250	250
xxx.xxSI1-262	270.00-281.99	210	244	259	BTSE 262	262
xxx.xxSI1-274	282.00-293.99	210	245	271	BTSE 274	274

Assembly D148	Tube D171, D173	Cutting Condition D252
----------------------	------------------------	-------------------------------

Assembly of TBTA9 series

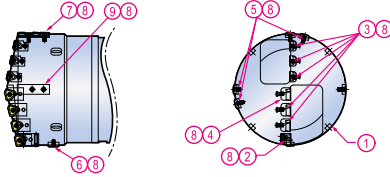

1. Head shank
2. Outer cartridge
3. Inner cartridge
4. Center cartridge
5. Guide pad
6. Sub guide pad
7. Guide pad protector
8. Lock screw
9. Filler

Parts		Diameter (mm)				
		233.00-247.99	248.00-253.99	254.00-258.99	259.00-264.99	265.00-271.99
Cartridge	Outer	PERC 402-43	PERC 402-63	PERC 402-63	PERC 402-63	PERC 402-63
	Adjust screw	AS0005-15	AS0006-15	AS0006-15	AS0006-15	AS0006-15
	Wrench	H2.5	H3	H3	H3	H3
	Screw	LS1806RH	L1806RH	L1806RH	L1806RH	L1806RH
	Wrench	H4	H4	H4	H4	H4
	Inner	CENC 402-43	CENC 402-43	CENC 402-43	CENC 402-43	CENC 402-43
	Screw	LS1206	LS1206	LS1206	LS1206	LS1206
	Wrench	H3L	H3L	H3L	H3L	H3L
	Center	CENC 402-63	CENC 402-63	CENC 402-63	CENC 402-63	CENC 402-63
	Screw	LS1206S	LS1206S	LS1206S	LS1206S	LS1206S
Wrench	H3L	H3L	H3L	H3L	H3L	
Insert	Outer	TPMX 240512R-G	TPMX 280716R-G	TPMX 280716R-G	TPMX 280716R-G	TPMX 280716R-G
	Screw	CSTB4M	CSTB5	CSTB5	CSTB5	CSTB5
	Wrench	T-15D	T-20D	T-20D	T-20D	T-20D
	Inner	TPMX 240512R-G	TPMX 240512R-G	TPMX 240512R-G	TPMX 240512R-G	TPMX 240512R-G
	Screw	CSTB4M	CSTB4M	CSTB4M	CSTB4M	CSTB4M
	Wrench	T-15D	T-15D	T-15D	T-15D	T-15D
	Center	TPMX 280716R-G	TPMX 280716R-G	TPMX 280716R-G	TPMX 280716R-G	TPMX 280716R-G
Screw	CSTB5	CSTB5	CSTB5	CSTB5	CSTB5	
Wrench	T-20D	T-20D	T-20D	T-20D	T-20D	
Pad	Guide pad	PAD-GP18-40-300-DC-SB	PAD-GP18-40-300-DC-SB	PAD-GP18-40-300-DC-SB	PAD-GP18-40-300-DC-SB	PAD-GP18-40-300-DC-SB
	Screw	LS1206S	LS1206S	LS1206S	LS1206S	LS1206S
	Wrench	H3	H3	H3	H3	H3
	Guide pad protector	PAD-P18	PAD-P18	PAD-P18	PAD-P18	PAD-P18
	Screw	LS1206S	LS1206S	LS1206S	LS1206S	LS1206S
	Wrench	H3	H3	H3	H3	H3
	Sub guide pad	PAD-S14	PAD-S14	PAD-S14	PAD-S14	PAD-S14
	Screw	CSTA5S	CSTA5S	CSTA5S	CSTA5S	CSTA5S
	Wrench	T-15D	T-15D	T-15D	T-15D	T-15D



TBTA9 Series



Assembly of TBTA9 series

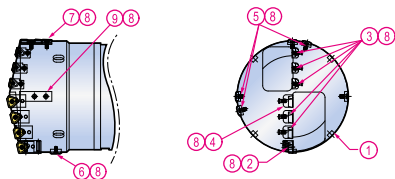

1. Head shank
2. Outer cartridge
3. Inner cartridge
4. Center cartridge
5. Guide pad
6. Sub guide pad
7. Guide pad protector
8. Lock screw
9. Filler

Parts		Diameter (mm)			
		272.00-275.99	276.00-284.99	285.00-289.99	290.00-293.99
Cartridge	Outer	PERC 402-63	PERC 402-63	PERC 402-63	PERC 402-63
	Adjust screw	AS0006-15	AS0006-15	AS0006-15	AS0006-15
	Wrench	H3	H3	H3	H3
	Screw	L1806RH	L1806RH	L1806RH	L1806RH
	Wrench	H4	H4	H4	H4
	Inner	CENC 402-63	CENC 402-63	CENC 402-63	CENC 402-63
	Screw	LS1206S	LS1206S	LS1206S	LS1206S
	Wrench	H3L	H3L	H3L	H3L
	Center	CENC 402-63	CENC 402-63	CENC 402-63	CENC 402-63
	Screw	LS1206S	LS1206S	LS1206S	LS1206S
Insert	Outer	TPMX 280716R-G	TPMX 280716R-G	TPMX 280716R-G	TPMX 280716R-G
	Screw	CSTB5	CSTB5	CSTB5	CSTB5
	Wrench	T-20D	T-20D	T-20D	T-20D
	Inner	TPMX 280716R-G	TPMX 280716R-G	TPMX 280716R-G	TPMX 280716R-G
	Screw	CSTB5	CSTB5	CSTB5	CSTB5
	Wrench	T-20D	T-20D	T-20D	T-20D
	Center	TPMX 280716R-G	TPMX 280716R-G	TPMX 280716R-G	TPMX 280716R-G
Pad	Guide pad	PAD-GP18-40-300-DC-SB	PAD-GP18-40-300-DC-SB	PAD-GP18-40-300-DC-SB	PAD-GP18-40-300-DC-SB
		PAD-GP18-40-300-DC-SC	PAD-GP18-40-300-DC-SC	PAD-GP18-40-300-DC-SC	PAD-GP18-40-300-DC-SC
	Screw	LS1206S	LS1206S	LS1206S	LS1206S
	Wrench	H3	H3	H3	H3
	Guide pad protector	PAD-P18	PAD-P18	PAD-P18	PAD-P18
	Screw	LS1206S	LS1206S	LS1206S	LS1206S
	Wrench	H3	H3	H3	H3
	Sub guide pad	PAD-S14	PAD-S14	PAD-S14	PAD-S14
	Screw	CSTA5S	CSTA5S	CSTA5S	CSTA5S
	Wrench	T-15D	T-15D	T-15D	T-15D

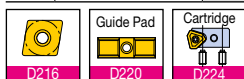

TBTA-FB...SI1



Single tube system

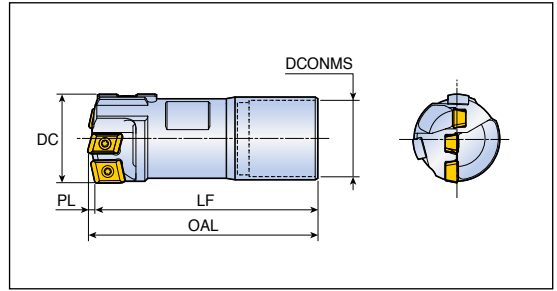

- Inner single start thread

Designation	DC	Dimension (mm)				Tube	
		LF	OAL	DCONMS	PL	Part	Diameter (mm)
TBTA-FB xx.xxSI1-22	25.00-26.99	70	73	20	3	BTSE 022	22
xx.xxSI1-24	27.00-29.00	70	73	22	3	BTSE 024	24
xx.xxSI1-24	29.01-29.99	70	73	22	3	BTSE 024	24
xx.xxSI1-26	30.00-31.99	75	78	24	3	BTSE 026	26
xx.xxSI1-28	32.00-33.99	75	78	26	3	BTSE 028	28
xx.xxSI1-30	34.00-36.99	90	93	27	3	BTSE 030	30
xx.xxSI1-33	37.00-39.99	95	98	30	3	BTSE 033	33
xx.xxSI1-36	40.00-43.99	100	104	33	4	BTSE 036	36
xx.xxSI1-39	44.00-46.99	105	109	37	4	BTSE 039	39
xx.xxSI1-43	47.00-51.99	105	109	41	4	BTSE 043	43
xx.xxSI1-47	52.00-56.99	110	114	44	4	BTSE 047	47
xx.xxSI1-51	57.00-60.99	115	120	49	5	BTSE 051	51
xx.xxSI1-56	61.00-65.00	115	120	53	5	BTSE 056	56
xx.xxSI1-56	65.01-67.99	104	112	53	8	BTSE 056	56
xx.xxSI1-62	68.00-74.99	104	113	59	9	BTSE 062	62
xx.xxSI1-68	75.00-80.99	134	143	65	9	BTSE 068	68
xx.xxSI1-75	81.00-89.00	134	143	71	9	BTSE 075	75

Assembly

D153

Tube

D172-D173

Cutting Condition

D254

▶ Insert and guide pad are sold separately from drill body



TBTA-FB Series



Assembly of TBTA-FB series

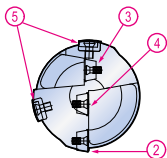
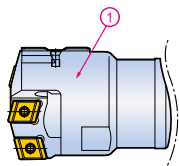

1. Head shank
2. Outer insert
3. Inner insert
4. Center insert
5. Guide pad

Parts	Diameter (mm)				
	25.00-28.00	28.01-29.99	30.00-35.00	35.01-38.00	
Insert	PER	NPHT 060304R-G-P	NPHT 060304R-G-P	NPHT 080404R-G-P	NPHT 080404R-G-P
	Screw	CSTB2.2	CSTB2.2	SR 14-560-HG	SR 14-560-HG
	Wrench	T-7F	T-7F	T-8F	T-8F
	INT	NPMT 060304R-G-I	NPMT 060304R-G-I	NPMT 070404R-G-I	NPMT 070404R-G-I
	Screw	CSTB2.2	CSTB2.2	SR 14-560-HG	SR 14-560-HG
	Wrench	T-7F	T-7F	T-8F	T-8F
	CEN	NPMT 060308L-G-C	NPMT 070408L-G-C	NPMT 070408L-G-C	NPMT 080480L-G-C
Pad	PAD	PAD-GP06-20-120-DC-SB	PAD-GP06-20-120-DC-SB	PAD-GP07-20-120-DC-SB	PAD-GP07-20-120-DC-SB
		PAD-GP06-20-120-DC-SC	PAD-GP06-20-120-DC-SC	PAD-GP07-20-120-DC-SC	PAD-GP07-20-120-DC-SC
	Screw	CSTB2.2S	CSTB2.2S	CSTB3S	CSTB3S
	Wrench	T-7F	T-7F	T-9F	T-9F

Parts	Diameter (mm)				
	38.01-39.00	39.01-41.00	41.01-44.00	44.01-45.00	
Insert	PER	NPHT 090404R-G-P	NPHT 090404R-G-P	NPHT 090404R-G-P	NPHT 090404R-G-P
	Screw	SR 14-560-HG	SR 14-560-HG	SR 14-560-HG	SR 14-560-HG
	Wrench	T-8F	T-8F	T-8F	T-8F
	INT	NPMT 070404R-G-I	NPMT 070404R-G-I	NPMT 080404R-G-I	NPMT 080404R-G-I
	Screw	SR 14-560-HG	SR 14-560-HG	SR 14-560-HG	SR 14-560-HG
	Wrench	T-8F	T-8F	T-8F	T-8F
	CEN	NPMT 080408L-G-C	NPMT 080408L-G-C	NPMT 080408L-G-C	NPMT 100408L-G-C
Pad	PAD	PAD-GP07-20-120-DC-SB	PAD-GP08-25-155-DC-SB	PAD-GP08-25-155-DC-SB	PAD-GP08-25-155-DC-SB
		PAD-GP07-20-120-DC-SC	PAD-GP08-25-155-DC-SC	PAD-GP08-25-155-DC-SC	PAD-GP08-25-155-DC-SC
	Screw	CSTB3S	CSTB3S	CSTB3S	CSTB3S
	Wrench	T-9F	T-9F	T-9F	T-9F



▶ Insert and guide pad are sold separately from drill body

Assembly of TBTA-FB series

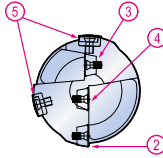
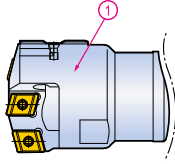

1. Head shank
2. Outer insert
3. Inner insert
4. Center insert
5. Guide pad

Parts		Diameter (mm)			
		45.01-47.00	47.01-51.00	51.01-54.00	54.01-57.00
Insert	PER	NPHT 090404R-G-P	NPHT 110404R-G-P	NPHT 110404R-G-P	NPHT 110404R-G-P
	Screw	SR 14-560-HG	SR 14-560-HG	SR 14-560-HG	SR 14-560-HG
	Wrench	T-8F	T-8F	T-8F	T-8F
	INT	NPMT 080404R-G-I	NPMT 080404R-G-I	NPMT 100404R-G-I	NPMT 100404R-G-I
	Screw	SR 14-560-HG	SR 14-560-HG	SR 14-560-HG	SR 14-560-HG
	Wrench	T-8F	T-8F	T-8F	T-8F
	CEN	NPMT 100408L-G-C	NPMT 100408L-G-C	NPMT 100408L-G-C	NPMT 130408L-G-C
	Screw	SR 14-560-HG	SR 14-560-HG	SR 14-560-HG	SR 14-560-HG
	Wrench	T-8F	T-8F	T-8F	T-8F
Pad	PAD	PAD-GP10-30-200-DC-SB	PAD-GP10-30-200-DC-SB	PAD-GP10-30-200-DC-SB	PAD-GP10-30-200-DC-SB
		PAD-GP10-30-200-DC-SC	PAD-GP10-30-200-DC-SC	PAD-GP10-30-200-DC-SC	PAD-GP10-30-200-DC-SC
	Screw	CSTB3.5	CSTB3.5	CSTB3.5	CSTB3.5
	Wrench	T-15F	T-15F	T-15F	T-15F

Parts		Diameter (mm)		
		57.01-60.00	60.01-64.00	64.01-65.00
Insert	PER	NPHT 110404R-G-P	NPHT 130404R-G-P	NPHT 130404R-G-P
	Screw	SR 14-560-HG	SR 14-560-HG	SR 14-560-HG
	Wrench	T-8F	T-8F	T-8F
	INT	NPMT 100404R-G-I	NPMT 100404R-G-I	NPMT 130404R-G-I
	Screw	SR 14-560-HG	SR 14-560-HG	SR 14-560-HG
	Wrench	T-8F	T-8F	T-8F
	CEN	NPMT 130408L-G-C	NPMT 130408L-G-C	NPMT 130408L-G-C
	Screw	SR 14-560-HG	SR 14-560-HG	SR 14-560-HG
	Wrench	T-8F	T-8F	T-8F
Pad	PAD	PAD-GP12-35-250-DC-SB	PAD-GP12-35-250-DC-SB	PAD-GP12-35-250-DC-SB
		PAD-GP12-35-250-DC-SC	PAD-GP12-35-250-DC-SC	PAD-GP12-35-250-DC-SC
	Screw	CSTB3.5	CSTB3.5	CSTB3.5
	Wrench	T-15F	T-15F	T-15F

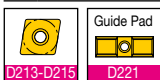

▶ Insert and guide pad are sold separately from drill body

TBTA-FB Series



Assembly of TBTA-FB series

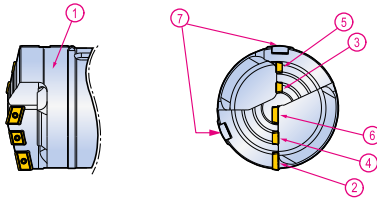

- 1. Head shank
- 2. Outer insert
- 3. Inner insert 1
- 4. Inner insert 2
- 5. Inner insert 3
- 6. Center insert
- 7. Guide pad

Parts	Diameter (mm)		
	65.01-71.00	71.01-83.00	83.01-89.00
PER	NPHT 110404R-G-P	NPHT 130404R-G-P	NPHT 130404R-G-P
Screw	SR 14-560-HG	SR 14-560-HG	SR 14-560-HG
Wrench	T-8F	T-8F	T-8F
INT	NPMT 080404R-G-I	NPMT 080404R-G-I	NPMT 080404R-G-I
Screw	SR 14-560-HG	SR 14-560-HG	SR 14-560-HG
Wrench	T-8F	T-8F	T-8F
INT2	NPMT 080404R-G-I	NPMT 080404R-G-I	NPMT 100404R-G-I
Screw	SR 14-560-HG	SR 14-560-HG	SR 14-560-HG
Wrench	T-8F	T-8F	T-8F
INT3	NPMT 070404R-G-I	NPMT 080404R-G-I	NPMT 080404R-G-I
Screw	SR 14-560-HG	SR 14-560-HG	SR 14-560-HG
Wrench	T-8F	T-8F	T-8F
CEN	NPMT 100408L-G-C	NPMT 100408L-G-C	NPMT 130408L-G-C
Screw	SR 14-560-HG	SR 14-560-HG	SR 14-560-HG
Wrench	T-8F	T-8F	T-8F
Pad	PAD	PAD-GP12-35-250-DC-SB	PAD-GP12-35-250-DC-SB
		PAD-GP12-35-250-DC-SC	PAD-GP12-35-250-DC-SC
	Screw	CSTB3.5	CSTB3.5
	Wrench	T-15F	T-15F



▶ Insert and guide pad are sold separately from drill body

TBTA-R...SI1



Single tube system

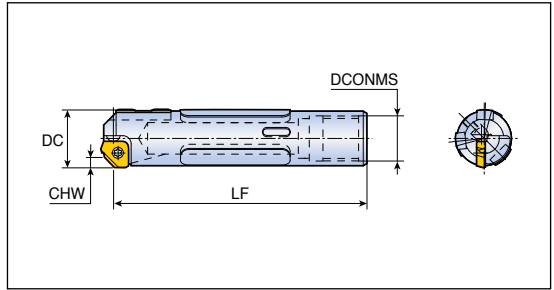

- Inner single start thread

Designation	DC	CHW (mm)	Dimension (mm)		Tube	
			LF	DCONMS	Part	Diameter (mm)
TBTA-R- xxx.xxSI1-22	25.00-26.99	2.8	110.5	20	BTSE 022	22
xxx.xxSI1-24	27.00-29.99	2.8	110.5	22	BTSE 024	24
xxx.xxSI1-26	30.00-31.99	2.8	110.5	24	BTSE 026	26
xxx.xxSI1-28	32.00-33.99	2.8	110.5	26	BTSE 028	28
xxx.xxSI1-30	34.00-36.99	2.8	135.5	27	BTSE 030	30
xxx.xxSI1-33	37.00-39.99	2.8	135.5	30	BTSE 033	33

TBTA-R...SI1



Single tube system

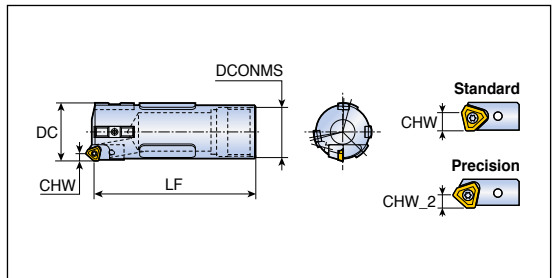

- Inner single start thread

Designation	DC	CHW (mm)		Dimension (mm)		Tube	
		Standard	Precision	LF	DCONMS	Part	Diameter (mm)
TBTA-R- xxx.xxSI1-36	40.00-43.99	6.4	4	135	33	BTSE 036	36
xxx.xxSI1-39	44.00-46.99	6.4	4	135	37	BTSE 039	39
xxx.xxSI1-43	47.00-51.99	6.4	4	145	41	BTSE 043	43
xxx.xxSI1-47	52.00-56.99	7.2	4.8	145	44	BTSE 047	47
xxx.xxSI1-51	57.00-60.99	7.2	4.8	170	49	BTSE 051	51
xxx.xxSI1-56	61.00-67.99	7.2/10.4	4.8/6.4	170	53	BTSE 056	56
xxx.xxSI1-62	68.00-74.99	10.4	6.4	170	59	BTSE 062	62
xxx.xxSI1-68	75.00-80.99	10.4	6.4	205	65	BTSE 068	68
xxx.xxSI1-75	81.00-90.99	10.4	6.4	215	71	BTSE 075	75
xxx.xxSI1-82	91.00-98.99	10.4	6.4	225	79	BTSE 082	82
xxx.xxSI1-94	99.00-110.99	10.4	6.4	235	90	BTSE 094	94

Assembly	Tube	Cutting Condition
D159	D172-D173	D252

Assembly of TBTA-R series

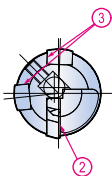
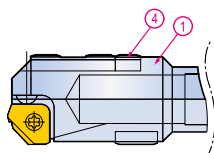

1. Head shank
2. Insert
3. Guide pad
4. Guide pad protector

Parts		Diameter (mm)					
		25.00-27.99	28.00-29.99	30.00-37.99	38.00-39.99		
Close tolerance	Cartridge	Adjust ball	BALL5	BALL5	BALL5	BALL5	
		Adjust screw	AS0005-5	AS0005-5	AS0005-5	AS0005-5	
		Wrench	H2.5	H2.5	H2.5	H2.5	
	Insert	Screw	-	-	-	-	
		Wrench	-	-	-	-	
		Insert	XPMT 16002-45	XPMT 16002-45	XPMT 16002-45	XPMT 16002-45	
Normal tolerance	Cartridge	Screw	CSTANO3	CSTANO3	CSTANO3	CSTANO3	
		Wrench	T-9D	T-9D	T-9D	T-9D	
		Insert	Outer	-	-	-	-
			Adjust screw	-	-	-	-
			Wrench	-	-	-	-
			Screw	-	-	-	-
	Wrench		-	-	-	-	
	Insert		XPMT 16002-45	XPMT 16002-45	XPMT 16002-45	XPMT 16002-45	
	Pad	Guide pad (A)	PAD-GP06-20-120-DC-SB	PAD-GP06-20-120-DC-SB	PAD-GP07-20-120-DC-SB	PAD-GP08-25-155-DC-SB	
			PAD-GP06-20-120-DC-SC	PAD-GP06-20-120-DC-SC	PAD-GP07-20-120-DC-SC	PAD-GP08-25-155-DC-SC	
		Screw	CSTB2.2S	CSTB2.2S	CSTB3S	CSTB3S	
		Wrench	T-9D	T-9D	T-9D	T-9D	
Guide pad protector (B)		-	-	-	PAD-P08		
		Screw	-	-	-	CSTB3S	
Wrench		-	-	-	T-9D		
Resin guide pad (C)		PAD-R10	PAD-R10	PAD-R12	PAD-R15		
		Screw	LS0902, 5-6	LS0902, 5-6	LS0903-8	LS0904-10	
Wrench		-	-	H2	H2.5		



- ▶ A+B is for outer four start thread connection type
- ▶ A+C is for inner single start thread connection type

Assembly of TBTA-R series

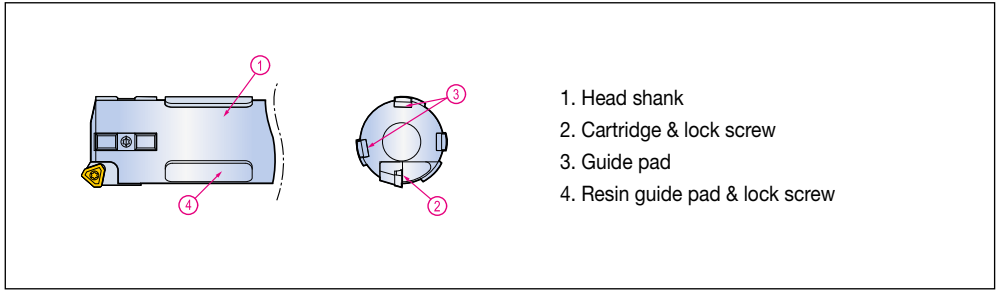

1. Head shank
2. Cartridge & lock screw
3. Guide pad
4. Resin guide pad & lock screw

Parts		Diameter (mm)				
		40.00-45.99	46.00-51.99	52.00-56.99	57.00-59.99	
Close tolerance	Cartridge	Outer	PERC-P 04R	PERC-P 04R	PERC-P 32R	PERC-P 32R
		Adjust screw	AS0004-8	AS0004-8	AS0005-10	AS0005-10
		Wrench	H2	H2	H2.5	H2.5
	Insert	Screw	LS1803.5RH	LS1803.5RH	LS1805RH	LS1805RH
		Wrench	H2.5	H2.5	H3	H3
		Insert	TPMX 1403LG	TPMX 1403LG	TPMX 1704LG	TPMX 1704LG
		Screw	CSTB2.5	CSTB2.5	CSTB3.5D	CSTB3.5D
Wrench	T-8D	T-8D	T-8D	T-8D		
Normal tolerance	Cartridge	Outer	PERC 402-04	PERC 402-04	PERC 402-32	PERC 402-32
		Adjust screw	AS0004-8	AS0004-8	AS0005-10	AS0005-10
		Wrench	H2	H2	H2.5	H2.5
	Insert	Screw	LS1803.5RH	LS1803.5RH	LS1805RH	LS1805RH
		Wrench	H2.5	H2.5	H3	H3
		Insert	TPMX 140308R-G	TPMX 140308R-G	TPMX 170408R-G	TPMX 170408R-G
		Screw	CSTB2.5	CSTB2.5	CSTB3.5D	CSTB3.5D
Wrench	T-8D	T-8D	T-8D	T-8D		
Pad	Guide pad (A)	PAD-GP08-25-155-DC-SB	PAD-GP10-35-200-DC-SB	PAD-GP10-35-200-DC-SB	PAD-GP10-35-200-DC-SB	
		PAD-GP08-25-155-DC-SC	PAD-GP10-35-200-DC-SC	PAD-GP10-35-200-DC-SC	PAD-GP10-35-200-DC-SC	
	Screw	CSTB3S	CSTB4S	CSTB4S	CSTB4S	
	Wrench	T-9D	T-15D	T-15D	T-15D	
	Guide pad protector (B)	PAD-P08	PAD-P10	PAD-P10	PAD-P14	
		Screw	CSTB3S	CSTB4S	CSTB4S	CSTB4S
	Wrench	T-9D	T-15D	T-15D	T-15D	
	Resin guide pad (C)	PAD-R15	PAD-R15	PAD-R15	PAD-R20	
		Screw	LS0904-10	LS0904-10	LS0904-10	LS0905-12
	Wrench	H2.5	H2.5	H2.5	H3	



- ▶ A+B is for outer four start thread connection type
- ▶ A+C is for inner single start thread connection type

Assembly of TBTA-R series

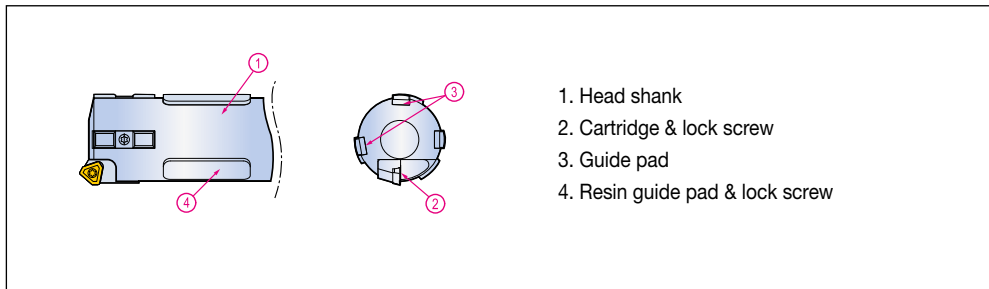

Parts		Diameter (mm)				
		60.00-66.99	67.00-99.99	100.00-122.99		
Close tolerance	Cartridge	Outer	PERC-P 32R	PERC-P 43R	PERC-P 43R	
		Adjust screw	AS0005-10	AS0005-15	AS0005-15	
		Wrench	H2.5	H2.5	H2.5	
	Insert	Screw	LS1805RH	LS1806RH	LS1806RH	
		Wrench	H3	H4	H4	
		Insert	TPMX 1704LG	TPMX 2405LG	TPMX 2405LG	
Normal tolerance	Cartridge	Screw	CSTB3.5D	CSTB4M	CSTB4M	
		Wrench	T-8D	T-15D	T-15D	
		Outer	PERC 402-32	PERC 402-43	PERC 402-43	
	Cartridge	Adjust screw	AS0005-10	AS0005-15	AS0005-15	
		Wrench	H2.5	H2.5	H2.5	
		Screw	LS1805RH	LS1806RH	LS1806RH	
	Insert	Wrench	H3	H4	H4	
		Insert	TPMX 170408R-G	TPMX 240512R-G	TPMX 240512R-G	
		Screw	CSTB3.5D	CSTB4M	CSTB4M	
	Insert	Wrench	T-8D	T-15D	T-15D	
		Pad	Guide pad (A)	PAD-GP14-40-250-DC-SB	PAD-GP14-40-250-DC-SB	PAD-GP18-40-300-DC-SB
				PAD-GP14-40-250-DC-SC	PAD-GP14-40-250-DC-SC	PAD-GP18-40-300-DC-SC
Screw	CSTA5S		CSTA5S	LS1206S		
Wrench	T-15D		T-15D	H3		
Guide pad protector (B)	PAD-P14		PAD-P14	PAD-P18		
	Screw		CSTA5S	CSTA5S	LS1206S	
Resin guide pad (C)	Wrench	T-15D	T-15D	H3		
	Screw	PAD-R20	PAD-R35	PAD-R35		
Resin guide pad (C)	Screw	LS0905-12	LS0906-15	LS0906-15		
	Wrench	H3	H4	H4		



- ▶ A+B is for outer four start thread connection type
- ▶ A+C is for inner single start thread connection type

Single tube system

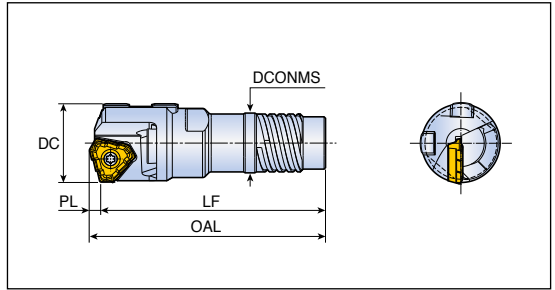

- Outer four start thread

Designation	DC	Dimension (mm)				Tube	
		LF	OAL	DCONMS	PL	Part	Diameter (mm)
TBTA-TRxx.xxSE4-14	16.00-16.70	55.0	57.2	12.6	2.2	BTSI 014	14
TRxx.xxSE4-15	16.71-17.70	55.0	57.2	13.6	2.2	BTSI 015	15
TRxx.xxSE4-16	17.71-18.90	56.0	59.0	14.5	3.0	BTSI 016	16
TRxx.xxSE4-17	18.91-20.00	56.0	59.0	15.5	3.0	BTSI 017	17
TRxx.xxSE4-18	20.01-21.80	60.0	63.2	16.0	3.2	BTSI 018	18
TRxx.xxSE4-20	21.81-21.99	63.5	66.7	18.0	3.2	BTSI 020	20
TRxx.xxSE4-20	22.00-24.10	65.5	68.9	18.0	3.4	BTSI 020	20
TRxx.xxSE4-22	24.11-26.40	65.5	69.1	19.5	3.6	BTSI 022	22
TRxx.xxSE4-24	26.41-28.00	65.6	69.1	21.0	3.6	BTSI 024	24
TRxx.xxSE4-24	28.01-28.70	70.0	74.6	21.0	4.6	BTSI 024	24
TRxx.xxSE4-26	28.71-29.99	75.0	79.6	23.5	4.6	BTSI 026	26
TRxx.xxSE4-26	30.00-31.00	75.0	79.6	23.5	4.6	BTSI 026	26
TRxx.xxSE4-28	31.01-32.00	75.0	79.6	25.5	4.6	BTSI 028	28
TRxx.xxSE4-28	32.01-33.30	74.5	79.9	25.5	5.4	BTSI 028	28
TRxx.xxSE4-30	33.31-36.20	79.5	84.9	28.0	5.4	BTSI 030	30
TRxx.xxSE4-33	36.21-39.00	89.5	94.9	30.0	5.4	BTSI 033	33
TRxx.xxSE4-33	39.01-39.60	89.5	94.9	30.0	5.4	BTSI 033	33
TRxx.xxSE4-36	39.61-40.00	94.5	99.9	33.0	5.4	BTSI 036	36

Assembly

D165

Tube

D170

Cutting Condition

D260

▶ Insert and guide pad are sold separately from drill body

Single tube system

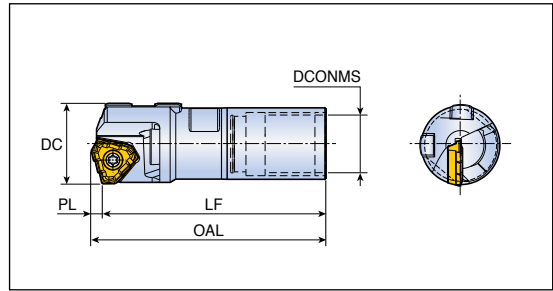

- Inner single start thread

Designation	DC	Dimension (mm)				Tube	
		LF	OAL	DCONMS	PL	Part	Diameter (mm)
TBTA- TR16.00S11-13A	16.00	53.5	55.7	10.8	2.2	BTSE 013A	13
TRxx.xxS11-13B	16.01-16.50	53.5	55.7	11.1	2.2	BTSE 013B	13
TRxx.xxS11-14A	16.51-17.25	53.5	55.7	11.8	2.2	BTSE 014A	14
TRxx.xxS11-14B	17.26-18.00	53.5	55.7	12.1	2.2	BTSE 014B	14
TRxx.xxS11-15	18.01-19.00	53.5	56.5	12.8	3.0	BTSE 015	15
TRxx.xxS11-16.5	19.01-19.99	53.5	56.7	13.8	3.2	BTSE 016.5	16.5
TRxx.xxS11-18	20.00-21.99	58.0	61.2	14.5	3.2	BTSE 018	18
TRxx.xxS11-20	22.00-24.99	60.0	63.4	16.0	3.4	BTSE 020	20
TRxx.xxS11-22	25.00	60.0	63.5	17.0	3.5	BTSE 022	22
TRxx.xxS11-22	25.01-26.99	65.0	68.5	17.0	3.5	BTSE 022	22
TRxx.xxS11-24	27.00-28.00	65.0	68.5	19.0	3.5	BTSE 024	24
TRxx.xxS11-24	28.01-29.99	70.0	74.6	22.0	4.6	BTSE 024	24
TRxx.xxS11-26	30.00-31.99	75.0	79.6	24.0	4.6	BTSE 026	26
TRxx.xxS11-28	32.00	75.0	79.6	26.0	4.6	BTSE 028	28
TRxx.xxS11-28	32.01-33.99	74.5	79.9	26.0	5.4	BTSE 028	28
TRxx.xxS11-30	34.00-36.99	89.5	94.9	27.0	5.4	BTSE 030	30
TRxx.xxS11-33	37.00-39.00	94.5	99.9	30.0	5.4	BTSE 033	33
TRxx.xxS11-33	39.01-39.99	94.5	99.9	30.0	5.4	BTSE 033	33
TRxx.xxS11-36	40.00	99.5	104.9	33.0	5.4	BTSE 036	36

Assembly D165	Tube D172	Cutting Condition D260
----------------------	------------------	----------------------------------

▶ Insert and guide pad are sold separately from drill body

TBTA-TR Series



Assembly of TBTA-TR series

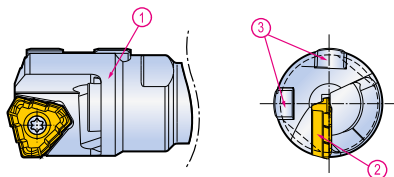

1. Head shank
2. Insert
3. Guide pad

Parts		Diameter (mm)		
		16.00-18.00	18.01-20.00	20.01-21.00
Insert	Insert	TOGT 080305 RS	TOGT 090305 RS	TOGT 100305 RS
	Screw	CSTB2.5S	CSTB2.5S*	CSTB3S*
	Wrench	T-8F	T-8F	T-9F
Guide Pad	Guide Pad	PAD-GP06-20-075-DC-SB	PAD-GP06-20-085-DC-SB	PAD-GP06-20-085-DC-SB
		PAD-GP06-20-075-DC-SC	PAD-GP06-20-085-DC-SC	PAD-GP06-20-085-DC-SC
	Screw	CSTB2.2S	CSTB2.2S*	CSTB2.2S*
	Wrench	T-7F	T-7F	T-7F

Parts		Diameter (mm)		
		21.01-21.99	22.00-25.00	25.01-28.00
Insert	Insert	TOGT 100305 RS	TOGT 110405 RS	TOGT 120405 RS
	Screw	CSTB3S*	SR14-571/S	CSTB4S
	Wrench	T-9F	T-10/5	T-15F
Guide Pad	Guide Pad	PAD-GP06-20-100-DC-SB	PAD-GP06-20-100-DC-SB	PAD-GP06-20-120-DC-SB
		PAD-GP06-20-100-DC-SC	PAD-GP06-20-100-DC-SC	PAD-GP06-20-120-DC-SC
	Screw	CSTB2.2S*	CSTB2.2S*	CSTB2.2S*
	Wrench	T-7F	T-7F	T-7F

Parts		Diameter (mm)			
		28.01-29.99	30.00-32.00	32.01-39.00	39.01-40.00
Insert	Insert	TOGT 130408 RS	TOGT 130408 RS	TOGT 140510 RS	TOGT 140510 RS
	Screw	SR 16-212/L10	SR 16-212/L10	SR 16-212/L10	SR 16-212/L10
	Wrench	T-20/5	T-20/5	T-20/5	T-20/5
Guide Pad	Guide Pad	PAD-GP06-20-120-DC-SB	PAD-GP07-20-120-DC-SB	PAD-GP07-20-120-DC-SB	PAD-GP08-25-155-DC-SB
		PAD-GP06-20-120-DC-SC	PAD-GP07-20-120-DC-SC	PAD-GP07-20-120-DC-SC	PAD-GP08-25-155-DC-SC
	Screw	CSTB2.2	CSTB3S	CSTB3S	CSTB3S
	Wrench	T-7F	T-9F	T-9F	T-9F



► Insert and guide pad are sold separately from drill body.

Single tube system



Ø12.60 - Ø15.59

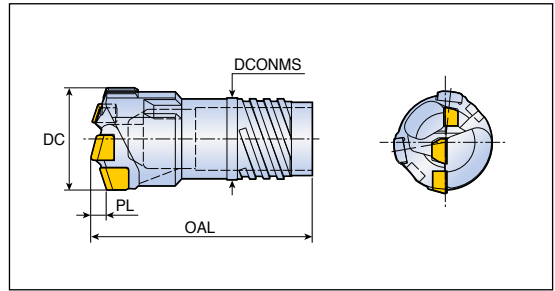

- Outer four start thread

Designation	DC	Dimension (mm)			Tube	
		OAL	PL	DCONMS	Part	Diameter (mm)
BTA xxx.xx SE2-11*	12.60-13.10	43.0	1.1	9.6	BTSI011	11
xxx.xx SE2-11*	13.11-13.60	43.0	1.1	9.6	BTSI011	11
xxx.xx SE2-12*	13.61-14.10	43.0	1.2	10.6	BTSI012	12
xxx.xx SE2-12*	14.11-14.60	43.0	1.2	10.6	BTSI012	12
xxx.xx SE2-13*	14.61-15.10	43.0	1.3	11.6	BTSI013	13
xxx.xx SE2-13*	15.11-15.59	43.0	1.3	11.6	BTSI013	13
xxx.xx SE4-14	15.60-16.20	43.0	2.7	12.6	BTSI014	14
xxx.xx SE4-14	16.21-16.70	43.0	2.7	12.6	BTSI014	14
xxx.xx SE4-15	16.71-17.20	43.0	2.7	13.6	BTSI015	15
xxx.xx SE4-15	17.21-17.70	43.0	2.7	13.6	BTSI015	15
xxx.xx SE4-16	17.71-18.40	47.0	2.8	14.5	BTSI016	16
xxx.xx SE4-16	18.41-18.90	47.0	2.9	14.5	BTSI016	16
xxx.xx SE4-17	18.91-19.20	47.0	2.9	15.5	BTSI017	17
xxx.xx SE4-17	19.21-20.00	47.0	2.9	15.5	BTSI017	17
xxx.xx SE4-18	20.01-20.90	52.5	3.2	16.0	BTSI018	18
xxx.xx SE4-18	20.91-21.80	52.5	3.2	16.0	BTSI018	18
xxx.xx SE4-20	21.81-22.90	56.0	3.2	18.0	BTSI020	20
xxx.xx SE4-20	22.91-24.10	56.0	3.2	18.0	BTSI020	20
xxx.xx SE4-22	24.11-25.20	57.5	3.5	19.5	BTSI022	22
xxx.xx SE4-22	25.21-26.40	57.5	3.5	19.5	BTSI022	22
xxx.xx SE4-24	26.41-27.50	57.5	3.7	21.0	BTSI024	24
xxx.xx SE4-24	27.51-28.70	57.5	3.7	21.0	BTSI024	24
xxx.xx SE4-26	28.71-29.80	63.5	4.0	23.5	BTSI026	26
xxx.xx SE4-26	29.81-31.00	63.5	4.0	23.5	BTSI026	26
xxx.xx SE4-28	31.01-32.10	63.5	4.3	25.5	BTSI028	28
xxx.xx SE4-28	32.11-33.30	63.5	4.3	25.5	BTSI028	28
xxx.xx SE4-30	33.31-34.80	63.5	4.5	28.0	BTSI030	30
xxx.xx SE4-30	34.81-36.20	63.5	4.5	28.0	BTSI030	30
xxx.xx SE4-33	36.21-37.30	73.5	4.8	30.0	BTSI033	33
xxx.xx SE4-33	37.31-38.40	73.5	4.8	30.0	BTSI033	33
xxx.xx SE4-33	38.41-39.60	73.5	4.8	30.0	BTSI033	33
xxx.xx SE4-36	39.61-40.60	73.5	5.6	33.0	BTSI036	36
xxx.xx SE4-36	40.61-41.80	73.5	5.6	33.0	BTSI036	36
xxx.xx SE4-36	41.81-43.00	73.5	5.6	33.0	BTSI036	36
xxx.xx SE4-39	43.01-44.30	75.0	5.4	36.0	BTSI039	39

► *: 2 cutting edge head, 2 start thread

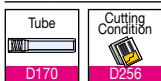

BTA...SE4



Single tube system

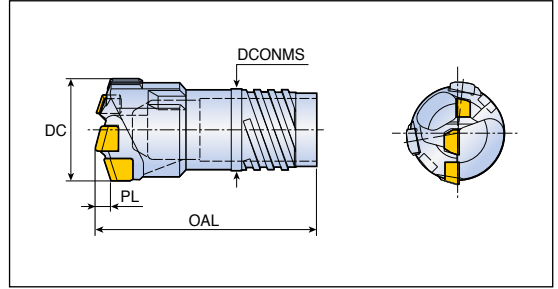

- Outer four start thread

Designation	DC	Dimension (mm)			Tube	
		OAL	PL	DCONMS	Part	Diameter (mm)
BTA xxx.xx SE4-39	44.31-45.60	75.0	5.4	36.0	BTSI039	39
xxx.xx SE4-39	45.61-47.00	75.0	5.4	36.0	BTSI039	39
xxx.xx SE4-43	47.01-48.50	75.0	6.1	39.0	BTSI043	43
xxx.xx SE4-43	48.51-50.10	75.0	6.1	39.0	BTSI043	43
xxx.xx SE4-43	50.11-51.70	75.0	6.1	39.0	BTSI043	43
xxx.xx SE4-47	51.71-53.20	82.0	6.5	43.0	BTSI047	47
xxx.xx SE4-47	53.21-54.70	82.0	6.5	43.0	BTSI047	47
xxx.xx SE4-47	54.71-56.20	82.0	6.5	43.0	BTSI047	47
xxx.xx SE4-51	56.21-58.40	84.0	6.6	47.0	BTSI051	51
xxx.xx SE4-51	58.41-60.60	84.0	6.6	47.0	BTSI051	51
xxx.xx SE4-51	60.61-62.80	84.0	7.0	47.0	BTSI051	51
xxx.xx SE4-51	62.81-65.00	84.0	7.0	47.0	BTSI051	51
xxx.xx SE4-56	60.61-62.80	84.0	7.0	51.0	BTSI056	56
xxx.xx SE4-56	62.81-65.00	84.0	7.0	51.0	BTSI056	56

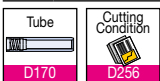

Double tube system

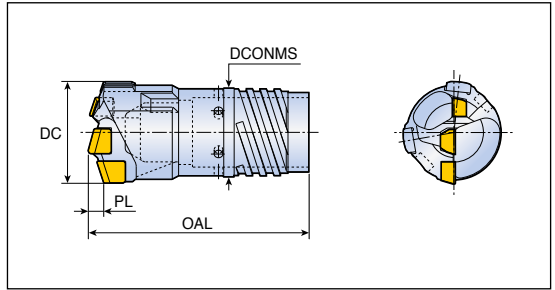

- Outer four start thread

Designation	DC	Dimension (mm)			Tube		
		OAL	PL	DCONMS	Outer tube	Inner tube	Diameter (mm)
BTA xxx.xx DE4-18	18.41-19.20	50.0	2.9	16.0	BTDO018	BTDI012	18.0
xxx.xx DE4-18	19.21-20.00	50.0	2.9	16.0	BTDO018	BTDI012	18.0
xxx.xx DE4-19.5	20.01-20.90	56.0	3.2	18.0	BTDO019.5	BTDI014	19.5
xxx.xx DE4-19.5	20.91-21.80	56.0	3.2	18.0	BTDO019.5	BTDI014	19.5
xxx.xx DE4-21.5	21.81-22.90	56.0	3.2	19.5	BTDO021.5	BTDI015	21.5
xxx.xx DE4-21.5	22.91-24.10	56.0	3.2	19.5	BTDO021.5	BTDI015	21.5
xxx.xx DE4-23.5	24.11-25.20	57.5	3.5	21.0	BTDO023.5	BTDI016	23.5
xxx.xx DE4-23.5	25.21-26.40	57.5	3.5	21.0	BTDO023.5	BTDI016	23.5
xxx.xx DE4-26	26.41-27.50	60.5	3.7	23.5	BTDO026	BTDI018	26.0
xxx.xx DE4-26	27.51-28.70	60.5	3.7	23.5	BTDO026	BTDI018	26.0
xxx.xx DE4-28	28.71-29.80	63.5	4.0	25.5	BTDO028	BTDI020	28.0
xxx.xx DE4-28	29.81-31.00	63.5	4.0	25.5	BTDO028	BTDI020	28.0
xxx.xx DE4-30.5	31.01-32.10	63.5	4.1	28.0	BTDO030.5	BTDI022	30.5
xxx.xx DE4-30.5	32.11-33.30	63.5	4.1	28.0	BTDO030.5	BTDI022	30.5
xxx.xx DE4-33	33.31-34.80	70.5	4.5	30.0	BTDO033.0	BTDI024	33.0
xxx.xx DE4-33	34.81-36.20	70.5	4.5	30.0	BTDO033.0	BTDI024	33.0
xxx.xx DE4-35.5	36.21-37.30	73.5	4.8	33.0	BTDO035.5	BTDI026	35.5
xxx.xx DE4-35.5	37.31-38.40	73.5	4.8	33.0	BTDO035.5	BTDI026	35.5
xxx.xx DE4-35.5	38.41-39.60	73.5	4.8	33.0	BTDO035.5	BTDI026	35.5
xxx.xx DE4-39	39.61-40.60	73.5	5.3	36.0	BTDO039	BTDI029	39.0
xxx.xx DE4-39	40.61-41.80	73.5	5.3	36.0	BTDO039	BTDI029	39.0
xxx.xx DE4-39	41.81-43.00	73.5	5.3	36.0	BTDO039	BTDI029	39.0
xxx.xx DE4-42.5	43.01-44.30	75.0	5.5	39.0	BTDO042.5	BTDI032	42.5
xxx.xx DE4-42.5	44.31-45.60	75.0	5.5	39.0	BTDO042.5	BTDI032	42.5
xxx.xx DE4-42.5	45.61-47.00	75.0	5.5	39.0	BTDO042.5	BTDI032	42.5
xxx.xx DE4-46.5	47.01-48.50	79.0	6.1	43.0	BTDO046.5	BTDI035	46.5
xxx.xx DE4-46.5	48.51-50.10	79.0	6.1	43.0	BTDO046.5	BTDI035	46.5
xxx.xx DE4-46.5	50.11-51.70	79.0	6.1	43.0	BTDO046.5	BTDI035	46.5
xxx.xx DE4-51	51.71-53.20	82.0	6.5	47.0	BTDO051	BTDI039	51.0
xxx.xx DE4-51	53.21-54.70	82.0	6.5	47.0	BTDO051	BTDI039	51.0
xxx.xx DE4-51	54.71-56.20	82.0	6.5	47.0	BTDO051	BTDI039	51.0
xxx.xx DE4-55.5	56.21-58.40	84.0	6.6	51.0	BTDO055.5	BTDI043A	55.5
xxx.xx DE4-55.5	58.41-60.60	84.0	6.6	51.0	BTDO055.5	BTDI043A	55.5
xxx.xx DE4-55.5	60.61-62.80	84.0	6.6	51.0	BTDO055.5	BTDI043A	55.5
xxx.xx DE4-55.5	62.81-65.00	84.0	6.6	51.0	BTDO055.5	BTDI043A	55.5

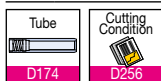

BTS...SE1



Single tube system

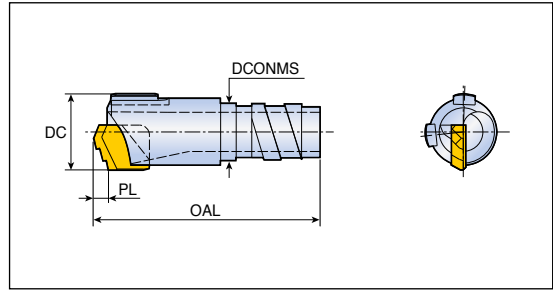

- Outer single start thread

Designation	DC	Dimension (mm)			Tube	
		OAL	PL	DCONMS	Part	Diameter (mm)
BTS xxx.xx SE1-7.1	8.00-8.99	34	2.0	6.0	BTSO071	7.1
xxx.xx SE1-8.3	9.00-9.99	34	2.0	7.2	BTSO083	8.3
xxx.xx SE1-9	10.00-10.99	34	2.2	7.6	BTSO090	9.0
xxx.xx SE1-10	11.00-11.99	34	2.2	8.6	BTSO100	10.0
xxx.xx SE1-11	12.00-13.49	34	2.3	9.1	BTSO110	11.0
xxx.xx SE1-12	13.50-14.79	34	2.4	10.8	BTSO120	12.0

BTS...SE2/SE4



Single tube system

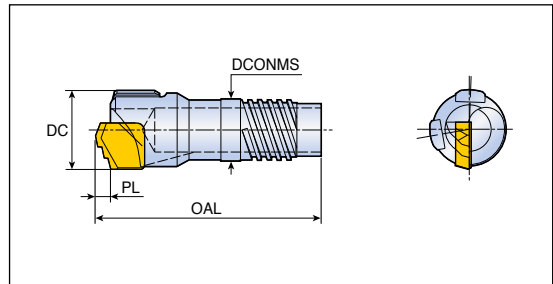

- Outer four start thread

Designation	DC	Dimension (mm)			Tube	
		OAL	PL	DCONMS	Part	Diameter (mm)
BTS xxx.xx SE2-11*	12.60-13.60	40	2.3	9.6	BTSI011	11
xxx.xx SE2-12*	13.61-14.60	40	2.4	10.6	BTSI012	12
xxx.xx SE2-13*	14.61-15.59	40	3.0	11.6	BTSI013	13
xxx.xx SE4-14	15.60-16.70	40	2.4	12.6	BTSI014	14
xxx.xx SE4-15	16.71-17.70	40	3.0	13.6	BTSI015	15
xxx.xx SE4-16	17.71-18.90	40	3.3	14.5	BTSI016	16
xxx.xx SE4-17	18.91-20.00	40	3.3	15.5	BTSI017	17



▶ *: Designates outer two start thread

Single tube

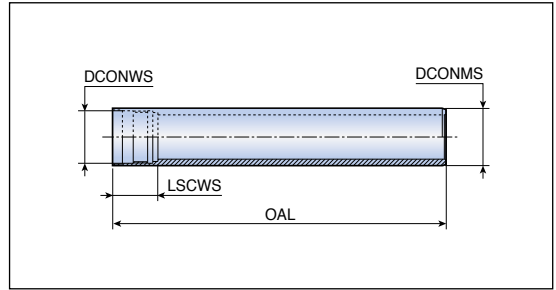

- Inner four start thread

Designation	DC	Dimension (mm)		
		DCONMS	DCONWS	LSCWS
BTSI 051	56.21-60.60	51.0	47.0	44
056A	60.61-65.00	56.0	51.0	44
056B	65.00-66.99	56.0	52.0	75
062	67.00-72.99	62.0	58.0	75
068	73.00-79.99	68.0	63.0	75
075	80.00-86.99	75.0	70.0	97
082	87.00-99.99	82.0	77.0	97
094	100.00-111.99	94.0	89.0	97
106	112.00-123.99	106.0	101.0	118
118	124.00-135.99	118.0	113.0	118
130	136.00-147.99	130.0	125.0	118
142	148.00-159.99	142.0	137.0	139
154	160.00-171.99	154.0	149.0	139
166	172.00-183.99	166.0	161.0	139
178	184.00-195.99	178.0	173.0	144
190	196.00-207.99	190.0	185.0	144
202	208.00-219.99	202.0	197.0	144
214	220.00-231.99	214.0	208.0	164
226	232.00-243.99	226.0	220.0	164
238	244.00-255.99	238.0	232.0	164
250	256.00-267.99	250.0	244.0	184
262	268.00-279.99	262.0	256.0	184
274	280.00-291.99	274.0	268.0	184

► Please indicate overall length (OAL) when ordering

Single tube

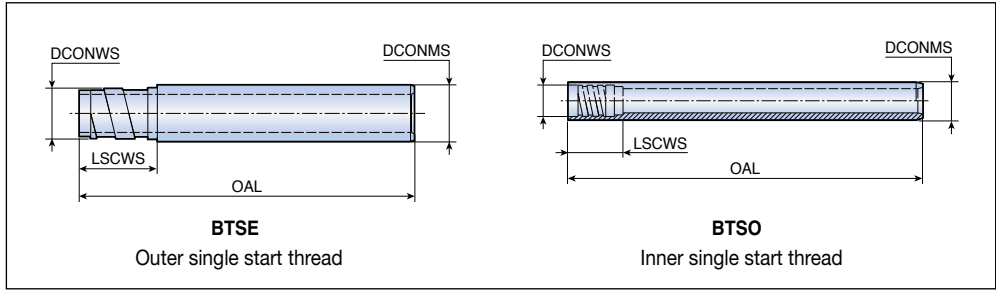

Designation	DC	Dimension (mm)			
		DCONMS	DCONWS		LSCWS
BTSE 047	52.00-56.99	47.0	44	-	41
051	57.00-60.99	51.0	49	-	41
056	61.00-67.99	56.0	53	-	41
062	68.00-74.99	62.0	59	-	41
068	75.00-80.99	68.0	65	-	71
075	81.00-90.99	75.0	71	-	71
082	91.00-98.99	82.0	79	-	71
094	99.00-110.99	94.0	90	-	71
106	111.00-122.99	106.0	102	-	71
118	123.00-134.99	118.0	114	-	71
130	135.00-148.99	130.0	126	-	71
142	149.00-161.99	142.0	139	-	71
154	162.00-173.99	154.0	151	-	86
166	174.00-185.99	166.0	163	-	86
178	186.00-197.99	178.0	175	-	86
190	198.00-209.99	190.0	187	-	86
202	210.00-221.99	202.0	199	-	86
214	222.00-233.99	214.0	211	-	86
226	234.00-245.99	226.0	223	-	86
238	246.00-257.99	238.0	235	-	86
250	258.00-269.99	250.0	247	-	121
262	270.00-281.99	262.0	259	-	121
274	282.00-293.99	274.0	271	-	121
BTSO 071	8.00-8.99	7.1	-	6.0	13.5
083	9.00-9.99	8.3	-	7.2	13.5
090	10.00-10.99	9.0	-	7.6	13.5
100	11.00-11.99	10.0	-	8.6	13.5
110	12.00-13.49	11.0	-	9.1	13.5
120	13.50-14.79	12.0	-	10.8	13.5

► Please indicate overall length (OAL) when ordering

Double tube

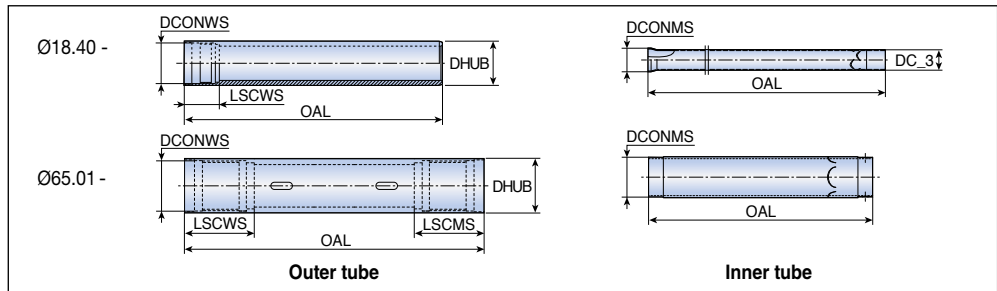

DC	Outer tube	Dimension (mm)			Inner tube	Dimension (mm)	
		DHUB	DCONWS	LSCWS		DCONMS	DC_3
18.40-20.00	BTDO 018	18.0	16	27.5	BTDI 012	12	10
20.01-21.80	019.5	19.5	18	30	014	14	12
21.81-24.10	021.5	21.5	19.5	30	015	15	13
24.11-26.40	023.5	23.5	21	30	016	16	14
26.41-28.70	026	26.0	23.5	33	018	18	16
28.71-31.00	028	28.0	25.5	33	020	20	18
31.01-33.30	030.5	30.5	28	33	022	22	20
33.31-36.20	033	33.0	30	40	024	24	22
36.21-39.60	035.5	35.5	33	40	026	26	24
39.61-43.00	039	39.0	36	40	029	29	27
43.01-47.00	042.5	42.5	39	40	032	32	30
47.01-51.70	046.5	46.5	43	44	035	35	32
51.71-56.20	051	51.0	47	44	039	39	36
56.21-65.00	055.5	55.5	51	44	043A	43	40
65.01-69.99	056	56.0	52	75	043B	40	-
70.00-72.99	062	62.0	58	75	048	44	-
73.00-79.99	068	68.0	63	75	053	48	-
80.00-86.99	075	75.0	70	97	059	54	-
87.00-99.99	082	82.0	77	97	066	60	-
100.00-111.99	094	94.0	89	97	078	70	-
112.00-123.99	106	106.0	101	118	090	80	-
124.00-135.99	118	118.0	113	118	092	80	-
136.00-147.99	130	130.0	125	118	104	95	-
148.00-159.99	142	142.0	137	139	116	100	-
160.00-171.99	154	154.0	149	139	128	120	-
172.00-183.99	166	166.0	161	139	138	130	-

- Please indicate overall length (OAL) when ordering
- For diameter range 18.40-65.00 (BTDO 055.5) the inner tube should be ordered 30mm longer than outer tube
- For diameter range 65.01-123.99 (BTDO 056-BTDO 106) the inner tube should be ordered 190mm longer than outer tube
- For diameter range 124.00-183.99 (BTDO 118-BTDO 166) the inner tube should be ordered 220mm longer than outer tube

Assembly of Double Tube System

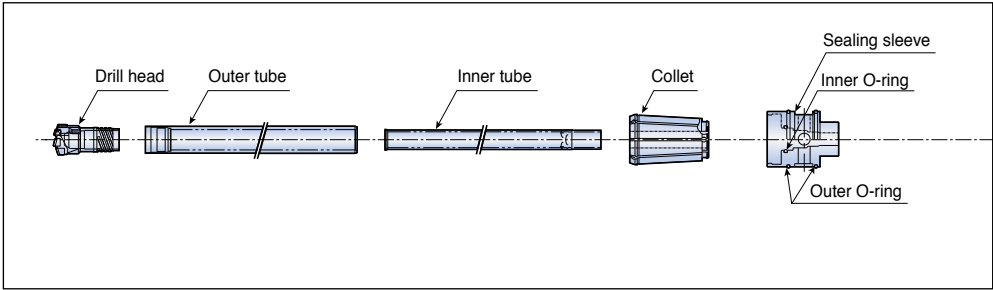

Designation		DC	Collet
BTDO 018	BTDI 012	18.40-19.20	COLLET 4-18
018	012	19.21-20.00	COLLET 4-18
019.5	014	20.01-20.90	COLLET 4-19.5
019.5	014	20.91-21.80	COLLET 4-19.5
021.5	015	21.81-22.90	COLLET 4-21.5
021.5	015	22.91-24.10	COLLET 4-21.5
023.5	016	24.11-25.20	COLLET 4-23.5
023.5	016	25.21-26.40	COLLET 4-23.5
026	018	26.41-27.50	COLLET 4-26
026	018	27.51-28.70	COLLET 4-26
028	020	28.71-29.80	COLLET 4-28
028	020	29.81-31.00	COLLET 4-28
030.5	022	31.01-32.10	COLLET 4-30.5
030.5	022	32.11-33.30	COLLET 4-30.5
033	024	33.31-34.80	COLLET 4-33
033	024	34.81-36.20	COLLET 4-33
035.5	026	36.21-37.30	COLLET 4-35.5
035.5	026	37.31-38.40	COLLET 4-35.5
035.5	026	38.41-39.60	COLLET 4-35.5
039	029	39.61-40.60	COLLET 4-39
039	029	40.61-41.80	COLLET 4-39
039	029	41.81-43.00	COLLET 4-39
042.5	032	43.01-44.30	COLLET 4-42.5
042.5	032	44.31-45.60	COLLET 4-42.5
042.5	032	45.61-47.00	COLLET 4-42.5
046.5	035	47.01-48.50	COLLET 4-46.5
046.5	035	48.51-50.10	COLLET 4-46.5
046.5	035	50.11-51.70	COLLET 4-46.5
051	039	51.71-53.20	COLLET 4-51
051	039	53.21-54.70	COLLET 4-51
051	039	54.71-56.20	COLLET 4-51
055.5	043A	56.21-58.40	COLLET 4-55.5
055.5	043A	58.41-60.60	COLLET 4-55.5
055.5	043A	60.61-62.80	COLLET 4-55.5
055.5	043A	62.81-65.00	COLLET 4-55.5

▶ Inner tube should be longer than outer tube. Please refer to page D174 for details

Assembly of Double Tube System



Connector

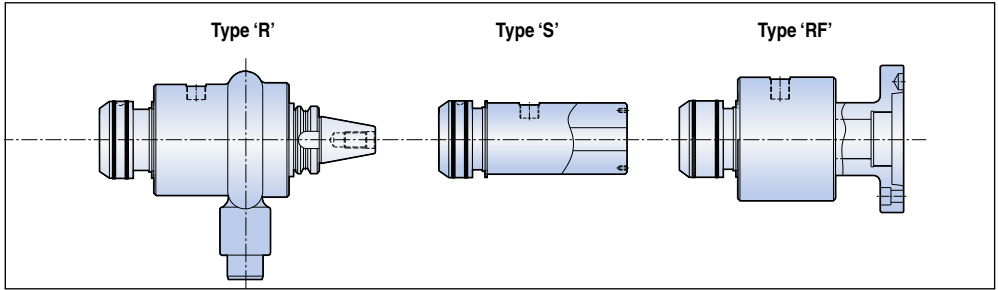

Sealing sleeve	Outer O-ring	Inner O-ring	Connector
SEALING SLEEVE 4R-18	OOR 25.24	IOR18	DTC-4S/4R/4RF
SEALING SLEEVE 4R-18		IOR18	
SEALING SLEEVE 4R-19.5		IOR19.5	
SEALING SLEEVE 4R-19.5		IOR19.5	
SEALING SLEEVE 4R-21.5		IOR21.5	
SEALING SLEEVE 4R-21.5		IOR21.5	
SEALING SLEEVE 4R-23.5		IOR23.5	
SEALING SLEEVE 4R-23.5		IOR23.5	
SEALING SLEEVE 4R-26		IOR26	
SEALING SLEEVE 4R-26		IOR26	
SEALING SLEEVE 4R-28		IOR28	
SEALING SLEEVE 4R-28		IOR28	
SEALING SLEEVE 4R-30.5		IOR30.5	
SEALING SLEEVE 4R-30.5		IOR30.5	
SEALING SLEEVE 4R-33	IOR33		
SEALING SLEEVE 4R-33	IOR33		
SEALING SLEEVE 4R-35.5	OOR65	IOR35.5	
SEALING SLEEVE 4R-35.5		IOR35.5	
SEALING SLEEVE 4R-35.5		IOR35.5	
SEALING SLEEVE 4R-39		IOR39	
SEALING SLEEVE 4R-39		IOR39	
SEALING SLEEVE 4R-39		IOR39	
SEALING SLEEVE 4R-42.5		IOR42.5	
SEALING SLEEVE 4R-42.5		IOR42.5	
SEALING SLEEVE 4R-42.5		IOR42.5	
SEALING SLEEVE 4R-46.5		IOR46.5	
SEALING SLEEVE 4R-46.5		IOR46.5	
SEALING SLEEVE 4R-46.5		IOR46.5	
SEALING SLEEVE 4R-51		IOR51	
SEALING SLEEVE 4R-51		IOR51	
SEALING SLEEVE 4R-51		IOR51	
SEALING SLEEVE 4R-55.5		IOR55.5	
SEALING SLEEVE 4R-55.5	IOR55.5		
SEALING SLEEVE 4R-55.5	IOR55.5		
SEALING SLEEVE 4R-55.5	IOR55.5		

'S' type connector

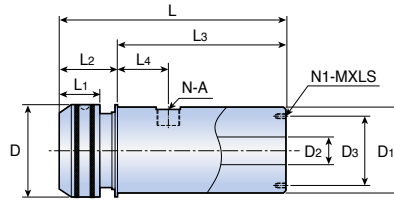

Designation	DC	D	D1	D2	D3	L	L1	L2	L3	L4	N-A	N1-MXLS
DTC 4S	18.4-65.0	115	100	45	80	310	50	60	250	68	2-PT3/4"	4-M8x15
5S	65.0-123.9	164	140	81	120	415	47	115	300		2-PT1"	6-M8x20

'R' type connector

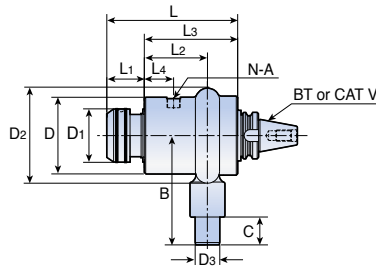

Designation	DC	D	D1	D2	D3	B	C	L	L1	L2	L3	L4	N-A
DTC 4R	18.4-65.0	165	115	206	53	186.5	60	319.7	59.2	152	228	75	2-PT1"
5R	65.0-123.9	225	164	312	100	310	100	382	62	201	320	95	2-PT1 1/4"
6R	124.0-183.9	350	244	445	152.4	412	120	487	75	250	412	118	4-PT1-1/4"

'RF' type connector

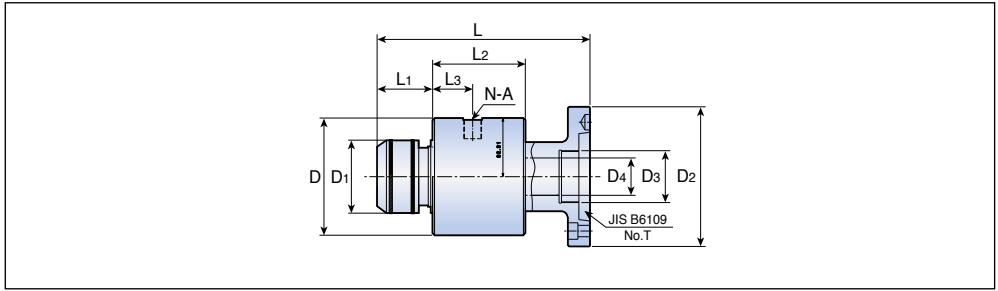

Designation	DC	D	D1	D2	D3	D4	L	L1	L2	L3	N-A
DTC 4RF	18.4-65.0	160	115	210	M62x2	46	291.5	64.5	150	75	2-PT1"

Collet / Sealing Sleeve

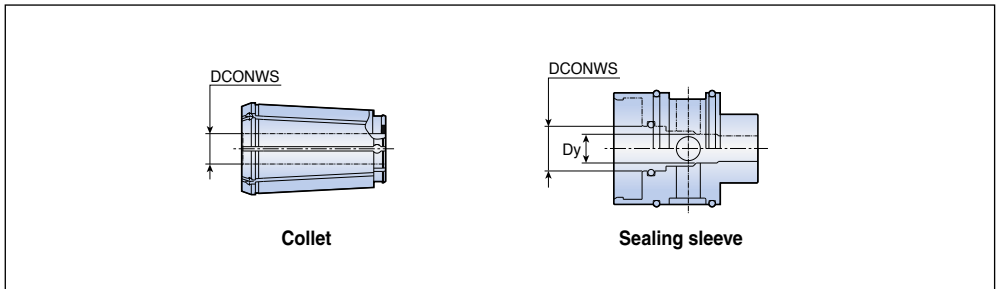

Designation	DC	DCONWS	Designation	DC	DCONWS	Dy	Outer O-ring	Inner O-ring
COLLET 4-18	18.40-20.00	18.0	SEALING SLEEVE 4-18	4-18	18.40-20.00	18.0	OOR 65	IOR 18
4-19.5	20.01-21.80	19.5		4-19.5	20.01-21.80	19.5		IOR 19.5
4-21.5	21.81-24.10	21.5		4-21.5	21.81-24.10	21.5		IOR 21.5
4-23.5	24.11-26.40	23.5		4-23.5	24.11-26.40	23.5		IOR 23.5
4-26	26.41-28.70	26.0		4-26	26.41-28.70	26.0		IOR 26
4-28	28.71-31.00	28.0		4-28	28.71-31.00	28.0		IOR 28
4-30.5	31.01-33.30	30.5		4-30.5	31.01-33.30	30.5		IOR 30.5
4-33	33.31-36.20	33.0		4-33	33.31-36.20	33.0		IOR 33
4-35.5	36.21-39.60	35.5		4-35.5	36.21-39.60	35.5		IOR 35.5
4-39	39.61-43.00	39.0		4-39	39.61-43.00	39.0		IOR 39
4-42.5	43.01-47.00	42.5		4-42.5	43.01-47.00	42.5		IOR 42.5
4-46.5	47.01-51.70	46.5		4-46.5	47.01-51.70	46.5		IOR 46.5
4-51	51.71-56.20	51.0		4-51	51.71-56.20	51.0		IOR 51
4-55.5	56.21-65.00	55.5		4-55.5	56.21-65.00	55.5		IOR 55.5

Drilling Heads & Inserts



SOMT...DP



Inserts for general purpose

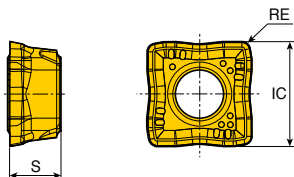

Size	Dimension (mm)		
	IC	S	RE
04	4.4	2.38	0.4
05	4.9	2.38	0.4
06	5.7	2.38	0.4
07	6.8	2.80	0.6
08	7.9	3.97	0.6
09	9.2	3.97	0.8
11	11.0	3.97	0.8
13	12.8	4.40	0.8
15	15.0	4.80	1.0

Insert	Designation	Coated						Uncoated	
		TT9080	TT8020	TT9300	TT9030	TT6030	TT7400	K10	
	SOMT 040204 DP	●	●	●					
	050204 DP	●	●	●					
	060204 DP	●	●	●					
	070306 DP	●	●	●					
	08T306 DP	●	●	●					
	09T308 DP	●	●	●					
	11T308 DP	●	●	●					
	130408 DP	●	●	●					
	150510 DP	●	●	●					



- ▶ TT9080: First choice for general purpose
- ▶ TT8020: For unstable condition
- ▶ TT9300: For high speed machining on a steel application (Peripheral **ONLY**)

●: Standard items

SOMT...DL



Inserts for low carbon steel

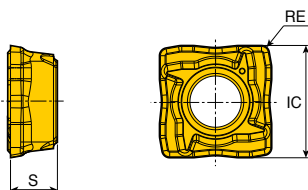

Size	Dimension (mm)		
	IC	S	RE
05	4.9	2.38	0.4
06	5.7	2.38	0.4
07	6.8	2.80	0.6
08	7.9	3.97	0.6
09	9.2	3.97	0.8
11	11.0	3.97	0.8
13	12.8	4.40	0.8
15	15.0	4.80	1.0

Insert	Designation	Coated						Uncoated	
		TT9080	TT9030	TT8020	TT6030	TT9300	TT7400	K10	
	SOMT 050204 DL	●							
	060204 DL	●							
	070306 DL	●							
	08T306 DL	●							
	09T308 DL	●							
	11T308 DL	●							
	130408 DL	●							
	150510 DL	●							



- ▶ TT9080: First choice for general purpose

●: Standard items

SOMT...DK



Inserts for cast iron

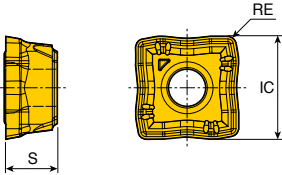

Size	Dimension (mm)		
	IC	S	RE
05	4.9	2.38	0.4
06	5.7	2.38	0.4
07	6.8	2.80	0.6
08	7.9	3.97	0.6
09	9.2	3.97	0.8
11	11.0	3.97	0.8
13	12.8	4.40	0.8
15	15.0	4.80	1.0

Insert	Designation	Coated						Uncoated	
		TT9080	TT8020	TT9300	TT9030	TT6030	TT6080	TT7400	K10
	SOMT 050204 DK						●		
	060204 DK						●		
	070306 DK						●		
	08T306 DK						●		
	09T308 DK						●		
	11T308 DK						●		
	130408 DK						●		
	150510 DK						●		



●: Standard items

SOMT...DA



Inserts for aluminum alloy

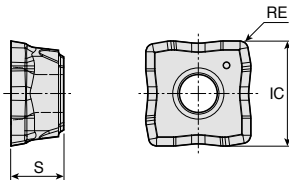

Size	Dimension (mm)		
	IC	S	RE
05	4.9	2.38	0.4
06	5.7	2.38	0.4
07	6.8	2.80	0.6
08	7.9	3.97	0.6
09	9.2	3.97	0.8
11	11.0	3.97	0.8
13	12.8	4.40	0.8
15	15.0	4.80	1.0

Insert	Designation	Coated						Uncoated	
		TT9080	TT8020	TT9300	TT9030	TT6030	TT6080	TT7400	K10
	SOMT 050204 DA								●
	060204 DA								●
	070306 DA								●
	08T306 DA								●
	09T308 DA								●
	11T308 DA								●
	130408 DA								●
	150510 DA								●



●: Standard items

SPMG...DG



Inserts for general purpose

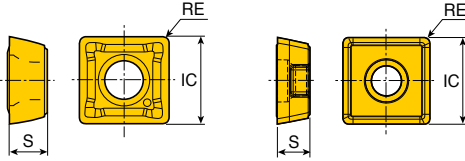

SPMG 120408 DG

Size	Dimension (mm)		
	IC	S	RE
05	5.00	2.38	0.4
06	6.00	2.38	0.4
07	7.94	3.97	0.8
09	9.80	4.30	0.8
11	11.50	4.80	0.8
12	12.70	4.76	0.8
14	14.30	5.20	1.2

Insert	Designation	Coated						Uncoated	
		TT9080	TT9030	TT8020	TT6030	TT9300	TT7400		
	SPMG 050204 DG		●	●			●		
	060204 DG		●	●			●		
	07T308 DG		●	●			●		
	090408 DG		●	●			●		
	110408 DG		●	●			●		
	120408 DG		●						
	140512 DG		●	●			●		



- ▶ TT9030: First choice for general purpose
- ▶ TT8020: For unstable condition
- ▶ TT7400: For high speed machining on a steel application (Peripheral **ONLY**)

●: Standard items

SPMG...DK



Inserts for cast iron

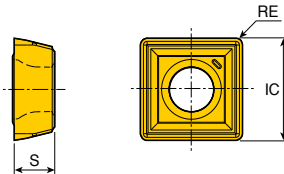

Size	Dimension (mm)		
	IC	S	RE
05	5.00	2.38	0.4
06	6.00	2.38	0.4
07	7.94	3.97	0.8
09	9.80	4.30	0.8
11	11.50	4.80	0.8
14	14.30	5.20	1.2

Insert	Designation	Coated						Uncoated	
		TT9080	TT9030	TT8020	TT6030	TT9300	TT7400		
	SPMG 050204 DK				●				
	060204 DK				●				
	07T308 DK				●				
	090408 DK				●				
	110408 DK				●				
	120408 DK								
	140512 DK				●				



●: Standard items

3 flute drill heads

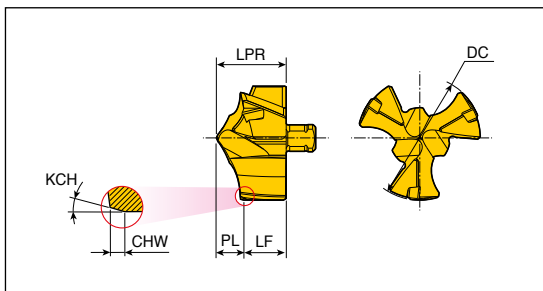

Designation	Dimension (mm)							Grade TT5130
	DC	LPR	PL	LF	CHW	KCH	SSC	
3ED-120-P+	12.0	6.7	2.74	3.96	0.4	15	12	●
121-P+	12.1	6.7	2.74	3.96	0.4	15	12	●
122-P+	12.2	6.7	2.74	3.96	0.4	15	12	●
123-P+	12.3	6.7	2.74	3.96	0.4	15	12	●
124-P+	12.4	6.7	2.74	3.96	0.4	15	12	●
125-P+	12.5	6.7	2.76	3.94	0.4	15	12	●
126-P+	12.6	6.7	2.76	3.94	0.4	15	12	●
127-P+	12.7	6.7	2.76	3.94	0.4	15	12	●
128-P+	12.8	6.7	2.76	3.94	0.4	15	12	●
129-P+	12.9	6.7	2.76	3.94	0.4	15	12	●
130-P+	13.0	7.3	2.91	4.39	0.4	15	13	●
131-P+	13.1	7.3	2.91	4.39	0.4	15	13	●
132-P+	13.2	7.3	2.91	4.39	0.4	15	13	●
133-P+	13.3	7.3	2.91	4.39	0.4	15	13	●
134-P+	13.4	7.3	2.91	4.39	0.4	15	13	●
135-P+	13.5	7.3	2.93	4.37	0.4	15	13	●
136-P+	13.6	7.3	2.93	4.37	0.4	15	13	●
137-P+	13.7	7.3	2.93	4.37	0.4	15	13	●
138-P+	13.8	7.3	2.93	4.37	0.4	15	13	●
139-P+	13.9	7.3	2.93	4.37	0.4	15	13	●
140-P+	14.0	7.9	3.17	4.73	0.4	15	14	●
141-P+	14.1	7.9	3.17	4.73	0.4	15	14	●
142-P+	14.2	7.9	3.17	4.73	0.4	15	14	●
143-P+	14.3	7.9	3.17	4.73	0.4	15	14	●
144-P+	14.4	7.9	3.17	4.73	0.4	15	14	●
145-P+	14.5	7.9	3.19	4.71	0.4	15	14	●
146-P+	14.6	7.9	3.19	4.71	0.4	15	14	●
147-P+	14.7	7.9	3.19	4.71	0.4	15	14	●
148-P+	14.8	7.9	3.19	4.71	0.4	15	14	●
149-P+	14.9	7.9	3.19	4.71	0.4	15	14	●
150-P+	15.0	8.4	3.31	5.09	0.5	30	15	●
151-P+	15.1	8.4	3.31	5.09	0.5	30	15	●
152-P+	15.2	8.4	3.31	5.09	0.5	30	15	●
153-P+	15.3	8.4	3.31	5.09	0.5	30	15	●
154-P+	15.4	8.4	3.31	5.09	0.5	30	15	●



► SSC: Seat size code

●: Standard items

3ED...-P+

3 flute drill heads

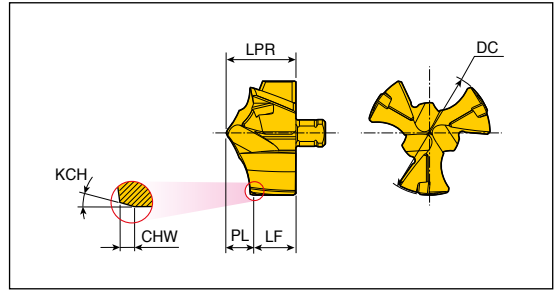

Designation	Dimension (mm)							Grade TT5130
	DC	LPR	PL	LF	CHW	KCH	SSC	
3ED-155-P+	15.5	8.4	3.32	5.08	0.5	30	15	●
156-P+	15.6	8.4	3.32	5.08	0.5	30	15	●
157-P+	15.7	8.4	3.32	5.08	0.5	30	15	●
158-P+	15.8	8.4	3.32	5.08	0.5	30	15	●
159-P+	15.9	8.4	3.32	5.08	0.5	30	15	●
160-P+	16.0	9.0	3.70	5.30	0.7	30	16	●
161-P+	16.1	9.0	3.70	5.30	0.7	30	16	●
162-P+	16.2	9.0	3.70	5.30	0.7	30	16	●
163-P+	16.3	9.0	3.70	5.30	0.7	30	16	●
164-P+	16.4	9.0	3.70	5.30	0.7	30	16	●
165-P+	16.5	9.0	3.71	5.29	0.7	30	16	●
166-P+	16.6	9.0	3.71	5.29	0.7	30	16	●
167-P+	16.7	9.0	3.71	5.29	0.7	30	16	●
168-P+	16.8	9.0	3.71	5.29	0.7	30	16	●
169-P+	16.9	9.0	3.71	5.29	0.7	30	16	●
170-P+	17.0	9.5	3.88	5.62	0.7	30	17	●
171-P+	17.1	9.5	3.88	5.62	0.7	30	17	●
172-P+	17.2	9.5	3.88	5.62	0.7	30	17	●
173-P+	17.3	9.5	3.88	5.62	0.7	30	17	●
174-P+	17.4	9.5	3.88	5.62	0.7	30	17	●
175-P+	17.5	9.5	3.89	5.61	0.7	30	17	●
176-P+	17.6	9.5	3.89	5.61	0.7	30	17	●
177-P+	17.7	9.5	3.89	5.61	0.7	30	17	●
178-P+	17.8	9.5	3.89	5.61	0.7	30	17	●
179-P+	17.9	9.5	3.89	5.61	0.7	30	17	●
180-P+	18.0	10.1	4.07	6.03	0.7	30	18	●
181-P+	18.1	10.1	4.07	6.03	0.7	30	18	●
182-P+	18.2	10.1	4.07	6.03	0.7	30	18	●
183-P+	18.3	10.1	4.07	6.03	0.7	30	18	●
184-P+	18.4	10.1	4.07	6.03	0.7	30	18	●
185-P+	18.5	10.1	4.08	6.02	0.7	30	18	●
186-P+	18.6	10.1	4.08	6.02	0.7	30	18	●
187-P+	18.7	10.1	4.08	6.02	0.7	30	18	●
188-P+	18.8	10.1	4.08	6.02	0.7	30	18	●
189-P+	18.9	10.1	4.08	6.02	0.7	30	18	●



► SSC: Seat size code

●: Standard items

D55-D57

3 flute drill heads

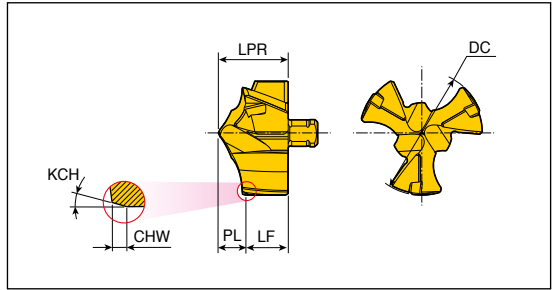

Designation	Dimension (mm)							Grade TT5130
	DC	LPR	PL	LF	CHW	KCH	SSC	
3ED-190-P+	19.0	10.7	4.26	6.44	0.7	30	19	●
191-P+	19.1	10.7	4.26	6.44	0.7	30	19	●
192-P+	19.2	10.7	4.26	6.44	0.7	30	19	●
193-P+	19.3	10.7	4.26	6.44	0.7	30	19	●
194-P+	19.4	10.7	4.26	6.44	0.7	30	19	●
195-P+	19.5	10.7	4.27	6.43	0.7	30	19	●
196-P+	19.6	10.7	4.27	6.43	0.7	30	19	●
197-P+	19.7	10.7	4.27	6.43	0.7	30	19	●
198-P+	19.8	10.7	4.27	6.43	0.7	30	19	●
199-P+	19.9	10.7	4.27	6.43	0.7	30	19	●
200-P+	20.0	11.3	4.44	6.86	0.7	30	20	●
201-P+	20.1	11.3	4.44	6.86	0.7	30	20	●
202-P+	20.2	11.3	4.44	6.86	0.7	30	20	●
203-P+	20.3	11.3	4.44	6.86	0.7	30	20	●
204-P+	20.4	11.3	4.44	6.86	0.7	30	20	●
205-P+	20.5	11.3	4.45	6.85	0.7	30	20	●
206-P+	20.6	11.3	4.45	6.85	0.7	30	20	●
207-P+	20.7	11.3	4.45	6.85	0.7	30	20	●
208-P+	20.8	11.3	4.45	6.85	0.7	30	20	●
209-P+	20.9	11.3	4.45	6.85	0.7	30	20	●
210-P+	21.0	11.8	4.62	7.18	0.4	15	21	●
215-P+	21.5	11.8	4.64	7.16	0.4	15	21	●
220-P+	22.0	12.4	4.78	7.62	0.4	15	22	●
225-P+	22.5	12.4	4.80	7.60	0.4	15	22	●
230-P+	23.0	12.8	5.02	7.78	0.4	15	23	●
235-P+	23.5	12.8	5.04	7.76	0.4	15	23	●
240-P+	24.0	13.4	5.18	8.22	0.4	15	24	●
245-P+	24.5	13.4	5.20	8.20	0.4	15	24	●
250-P+	25.0	14.0	5.29	8.71	0.4	15	25	●
255-P+	25.5	14.0	5.31	8.69	0.4	15	25	●



► SSC: Seat size code

●: Standard items

D65-D57

TCD...P/M/K



Drill heads

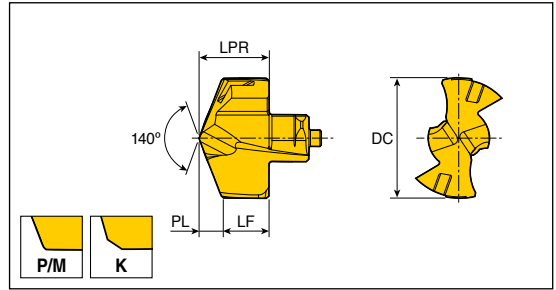

Designation	Dimension (mm)					Grade TT9080
	DC	LPR	PL	LF	SSC	
TCD - 060-P/M/K	6.0	4.0	0.96	3.04	6	●
061-P/M/K	6.1	4.0	0.98	3.02	6	●
062-P/M/K	6.2	4.0	1.00	3.00	6	●
063-P/M/K	6.3	4.0	1.01	2.99	6	●
064-P/M/K	6.4	4.0	1.03	2.97	6	●
065-P/M/K	6.5	4.3	1.18	3.12	6.5	●
066-P/M/K	6.6	4.3	1.20	3.10	6.5	●
067-P/M/K	6.7	4.3	1.22	3.08	6.5	●
068-P/M/K	6.8	4.3	1.23	3.07	6.5	●
069-P/M/K	6.9	4.3	1.25	3.05	6.5	●
070-P/M/K	7.0	4.6	1.01	3.59	7	●
071-P/M/K	7.1	4.6	1.03	3.57	7	●
072-P/M/K	7.2	4.6	1.05	3.55	7	●
073-P/M/K	7.3	4.6	1.06	3.54	7	●
074-P/M/K	7.4	4.6	1.08	3.52	7	●
075-P/M/K	7.5	4.6	1.10	3.50	7	●
076-P/M/K	7.6	4.6	1.12	3.48	7	●
077-P/M/K	7.7	4.6	1.14	3.46	7	●
078-P/M/K	7.8	4.6	1.16	3.44	7	●
079-P/M/K	7.9	4.6	1.17	3.43	7	●
080-P/M/K	8.0	5.4	1.20	4.20	8	●
081-P/M/K	8.1	5.4	1.22	4.18	8	●
082-P/M/K	8.2	5.4	1.24	4.16	8	●
083-P/M/K	8.3	5.4	1.25	4.15	8	●
084-P/M/K	8.4	5.4	1.27	4.13	8	●
085-P/M/K	8.5	5.4	1.29	4.11	8	●
086-P/M/K	8.6	5.4	1.31	4.09	8	●
087-P/M/K	8.7	5.4	1.33	4.07	8	●
088-P/M/K	8.8	5.4	1.35	4.05	8	●
089-P/M/K	8.9	5.4	1.36	4.04	8	●
090-P/M/K	9.0	5.8	1.35	4.45	9	●
091-P/M/K	9.1	5.8	1.37	4.43	9	●
092-P/M/K	9.2	5.8	1.39	4.41	9	●
093-P/M/K	9.3	5.8	1.40	4.40	9	●
094-P/M/K	9.4	5.8	1.42	4.38	9	●

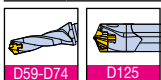

► Drill head can be ordered by an application
 Order example) Diameter 10.0mm drill head for
 ISO P application: TCD-100-P TT9080

●: Standard items

P Steel **M** Stainless steel **K** Cast iron

Drill heads

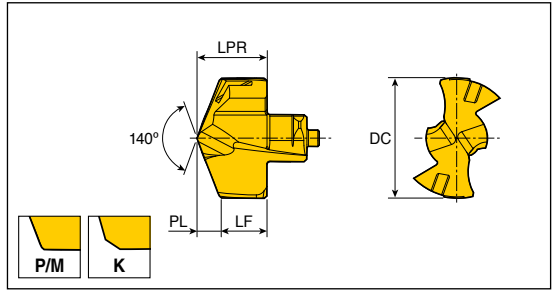

Designation	Dimension (mm)					Grade
	DC	LPR	PL	LF	SSC	
TCD - 095-P/M/K	9.5	5.8	1.44	4.36	9	●
096-P/M/K	9.6	5.8	1.46	4.34	9	●
097-P/M/K	9.7	5.8	1.48	4.32	9	●
098-P/M/K	9.8	5.8	1.50	4.30	9	●
099-P/M/K	9.9	5.8	1.51	4.29	9	●
100-P/M/K	10.0	6.2	1.50	4.70	10	●
101-P/M/K	10.1	6.2	1.52	4.68	10	●
102-P/M/K	10.2	6.2	1.54	4.66	10	●
103-P/M/K	10.3	6.2	1.55	4.65	10	●
104-P/M/K	10.4	6.2	1.57	4.63	10	●
105-P/M/K	10.5	6.2	1.59	4.61	10	●
106-P/M/K	10.6	6.2	1.61	4.59	10	●
107-P/M/K	10.7	6.2	1.63	4.57	10	●
108-P/M/K	10.8	6.2	1.65	4.55	10	●
109-P/M/K	10.9	6.2	1.66	4.54	10	●
110-P/M/K	11.0	6.6	1.67	4.93	11	●
111-P/M/K	11.1	6.6	1.69	4.91	11	●
112-P/M/K	11.2	6.6	1.71	4.89	11	●
113-P/M/K	11.3	6.6	1.72	4.88	11	●
114-P/M/K	11.4	6.6	1.74	4.86	11	●
115-P/M/K	11.5	6.6	1.76	4.84	11	●
116-P/M/K	11.6	6.6	1.78	4.82	11	●
117-P/M/K	11.7	6.6	1.80	4.80	11	●
118-P/M/K	11.8	6.6	1.82	4.78	11	●
119-P/M/K	11.9	6.6	1.83	4.77	11	●
120-P/M/K	12.0	7.0	1.82	5.18	12	●
121-P/M/K	12.1	7.0	1.84	5.16	12	●
122-P/M/K	12.2	7.0	1.86	5.14	12	●
123-P/M/K	12.3	7.0	1.87	5.13	12	●
124-P/M/K	12.4	7.0	1.89	5.11	12	●
125-P/M/K	12.5	7.0	1.91	5.09	12	●
126-P/M/K	12.6	7.0	1.93	5.07	12	●
127-P/M/K	12.7	7.0	1.95	5.05	12	●
128-P/M/K	12.8	7.0	1.97	5.03	12	●
129-P/M/K	12.9	7.0	1.98	5.02	12	●

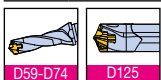

▶ Drill head can be ordered by an application
 Order example) Diameter 10.0mm drill head for
 ISO P application: TCD-100-P TT9080

●: Standard items



Steel



Stainless steel



Cast iron

Drill heads

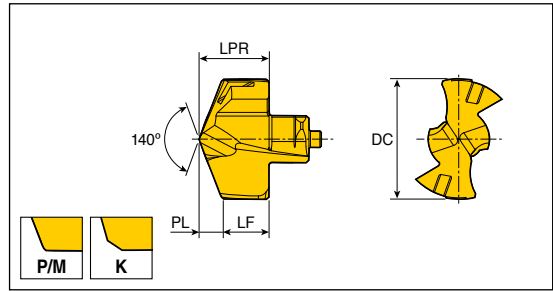

Designation	Dimension (mm)					Grade
	DC	LPR	PL	LF	SSC	TT9080
TCD - 130-P/M/K	13.0	7.6	1.96	5.64	13	●
131-P/M/K	13.1	7.6	1.98	5.62	13	●
132-P/M/K	13.2	7.6	2.00	5.60	13	●
133-P/M/K	13.3	7.6	2.01	5.59	13	●
134-P/M/K	13.4	7.6	2.03	5.57	13	●
135-P/M/K	13.5	7.6	2.05	5.55	13	●
136-P/M/K	13.6	7.6	2.07	5.53	13	●
137-P/M/K	13.7	7.6	2.09	5.51	13	●
138-P/M/K	13.8	7.6	2.11	5.49	13	●
139-P/M/K	13.9	7.6	2.12	5.48	13	●
140-P/M/K	14.0	8.1	2.12	5.98	14	●
141-P/M/K	14.1	8.1	2.14	5.96	14	●
142-P/M/K	14.2	8.1	2.16	5.94	14	●
143-P/M/K	14.3	8.1	2.17	5.93	14	●
144-P/M/K	14.4	8.1	2.19	5.91	14	●
145-P/M/K	14.5	8.1	2.21	5.89	14	●
146-P/M/K	14.6	8.1	2.23	5.87	14	●
147-P/M/K	14.7	8.1	2.25	5.85	14	●
148-P/M/K	14.8	8.1	2.27	5.83	14	●
149-P/M/K	14.9	8.1	2.28	5.82	14	●
150-P/M/K	15.0	8.7	2.27	6.43	15	●
151-P/M/K	15.1	8.7	2.29	6.41	15	●
152-P/M/K	15.2	8.7	2.31	6.39	15	●
153-P/M/K	15.3	8.7	2.32	6.38	15	●
154-P/M/K	15.4	8.7	2.34	6.36	15	●
155-P/M/K	15.5	8.7	2.36	6.34	15	●
156-P/M/K	15.6	8.7	2.38	6.32	15	●
157-P/M/K	15.7	8.7	2.40	6.30	15	●
158-P/M/K	15.8	8.7	2.42	6.28	15	●
159-P/M/K	15.9	8.7	2.43	6.27	15	●
160-P/M/K	16.0	9.3	2.42	6.88	16	●
161-P/M/K	16.1	9.3	2.44	6.86	16	●
162-P/M/K	16.2	9.3	2.46	6.84	16	●
163-P/M/K	16.3	9.3	2.47	6.83	16	●
164-P/M/K	16.4	9.3	2.49	6.81	16	●



D59-D74



D125

► Drill head can be ordered by an application
 Order example) Diameter 10.0mm drill head for
 ISO P application: TCD-100-P TT9080

●: Standard items



Stainless steel



Cast iron

Drill heads

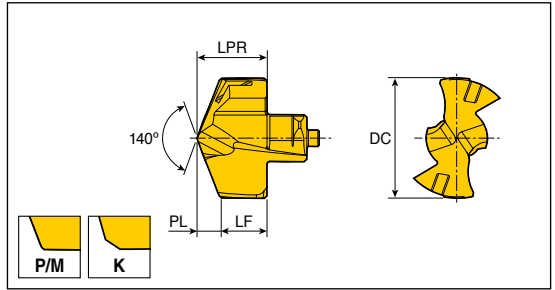

Designation	Dimension (mm)					Grade
	DC	LPR	PL	LF	SSC	
TCD - 165-P/M/K	16.5	9.3	2.51	6.79	16	●
166-P/M/K	16.6	9.3	2.53	6.77	16	●
167-P/M/K	16.7	9.3	2.55	6.75	16	●
168-P/M/K	16.8	9.3	2.57	6.73	16	●
169-P/M/K	16.9	9.3	2.58	6.72	16	●
170-P/M/K	17.0	9.9	2.59	7.31	17	●
171-P/M/K	17.1	9.9	2.61	7.29	17	●
172-P/M/K	17.2	9.9	2.63	7.27	17	●
173-P/M/K	17.3	9.9	2.64	7.26	17	●
174-P/M/K	17.4	9.9	2.66	7.24	17	●
175-P/M/K	17.5	9.9	2.68	7.22	17	●
176-P/M/K	17.6	9.9	2.70	7.20	17	●
177-P/M/K	17.7	9.9	2.72	7.18	17	●
178-P/M/K	17.8	9.9	2.74	7.16	17	●
179-P/M/K	17.9	9.9	2.75	7.15	17	●
180-P/M/K	18.0	10.5	2.73	7.77	18	●
181-P/M/K	18.1	10.5	2.75	7.75	18	●
182-P/M/K	18.2	10.5	2.77	7.73	18	●
183-P/M/K	18.3	10.5	2.78	7.72	18	●
184-P/M/K	18.4	10.5	2.80	7.70	18	●
185-P/M/K	18.5	10.5	2.82	7.68	18	●
186-P/M/K	18.6	10.5	2.84	7.66	18	●
187-P/M/K	18.7	10.5	2.86	7.64	18	●
188-P/M/K	18.8	10.5	2.88	7.62	18	●
189-P/M/K	18.9	10.5	2.89	7.61	18	●
190-P/M/K	19.0	11.0	2.88	8.12	19	●
191-P/M/K	19.1	11.0	2.90	8.10	19	●
192-P/M/K	19.2	11.0	2.92	8.08	19	●
193-P/M/K	19.3	11.0	2.93	8.07	19	●
194-P/M/K	19.4	11.0	2.95	8.05	19	●
195-P/M/K	19.5	11.0	2.97	8.03	19	●
196-P/M/K	19.6	11.0	2.99	8.01	19	●
197-P/M/K	19.7	11.0	3.01	7.99	19	●
198-P/M/K	19.8	11.0	3.03	7.97	19	●
199-P/M/K	19.9	11.0	3.04	7.96	19	●

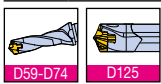

▶ Drill head can be ordered by an application
 Order example) Diameter 10.0mm drill head for
 ISO P application: TCD-100-P TT9080

●: Standard items

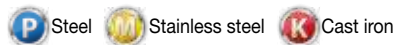

Drill heads

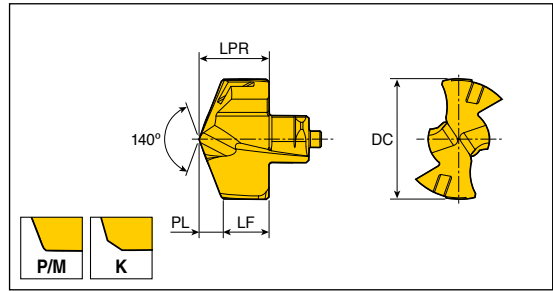

Designation	Dimension (mm)					Grade
	DC	LPR	PL	LF	SSC	TT9080
TCD - 200-P/M/K	20.0	11.6	3.02	8.58	20	●
201-P/M/K	20.1	11.6	3.04	8.56	20	●
202-P/M/K	20.2	11.6	3.06	8.54	20	●
203-P/M/K	20.3	11.6	3.07	8.53	20	●
204-P/M/K	20.4	11.6	3.09	8.51	20	●
205-P/M/K	20.5	11.6	3.11	8.49	20	●
206-P/M/K	20.6	11.6	3.13	8.47	20	●
207-P/M/K	20.7	11.6	3.15	8.45	20	●
208-P/M/K	20.8	11.6	3.17	8.43	20	●
209-P/M/K	20.9	11.6	3.18	8.42	20	●
210-P/M/K	21.0	12.1	3.18	8.92	21	●
211-P/M/K	21.1	12.1	3.20	8.90	21	●
212-P/M/K	21.2	12.1	3.22	8.88	21	●
213-P/M/K	21.3	12.1	3.23	8.87	21	●
214-P/M/K	21.4	12.1	3.25	8.85	21	●
215-P/M/K	21.5	12.1	3.27	8.83	21	●
216-P/M/K	21.6	12.1	3.29	8.81	21	●
217-P/M/K	21.7	12.1	3.31	8.79	21	●
218-P/M/K	21.8	12.1	3.33	8.77	21	●
219-P/M/K	21.9	12.1	3.34	8.76	21	●
220-P/M/K	22.0	12.7	3.24	9.46	22	●
221-P/M/K	22.1	12.7	3.26	9.44	22	●
222-P/M/K	22.2	12.7	3.28	9.42	22	●
223-P/M/K	22.3	12.7	3.29	9.41	22	●
224-P/M/K	22.4	12.7	3.31	9.39	22	●
225-P/M/K	22.5	12.7	3.33	9.37	22	●
226-P/M/K	22.6	12.7	3.35	9.35	22	●
227-P/M/K	22.7	12.7	3.37	9.33	22	●
228-P/M/K	22.8	12.7	3.39	9.31	22	●
229-P/M/K	22.9	12.7	3.40	9.30	22	●
230-P/M/K	23.0	13.3	3.46	9.84	23	●
231-P/M/K	23.1	13.3	3.48	9.82	23	●
232-P/M/K	23.2	13.3	3.50	9.80	23	●
233-P/M/K	23.3	13.3	3.51	9.79	23	●
234-P/M/K	23.4	13.3	3.53	9.77	23	●



D59-D74



D125

► Drill head can be ordered by an application
 Order example) Diameter 10.0mm drill head for
 ISO P application: TCD-100-P TT9080

●: Standard items



Stainless steel



Cast iron

Drill heads

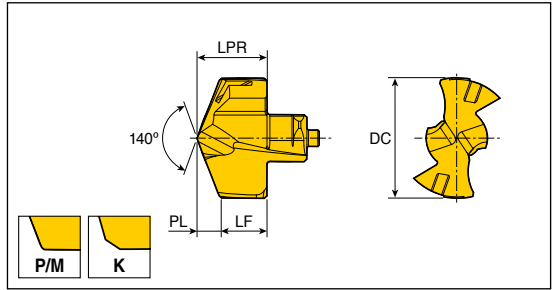

Designation	Dimension (mm)					Grade
	DC	LPR	PL	LF	SSC	
TCD - 235-P/M/K	23.5	13.3	3.55	9.75	23	●
236-P/M/K	23.6	13.3	3.57	9.73	23	●
237-P/M/K	23.7	13.3	3.59	9.71	23	●
238-P/M/K	23.8	13.3	3.61	9.69	23	●
239-P/M/K	23.9	13.3	3.62	9.68	23	●
240-P/M/K	24.0	13.9	3.62	10.28	24	●
241-P/M/K	24.1	13.9	3.64	10.26	24	●
242-P/M/K	24.2	13.9	3.66	10.24	24	●
243-P/M/K	24.3	13.9	3.67	10.23	24	●
244-P/M/K	24.4	13.9	3.69	10.21	24	●
245-P/M/K	24.5	13.9	3.71	10.19	24	●
246-P/M/K	24.6	13.9	3.73	10.17	24	●
247-P/M/K	24.7	13.9	3.75	10.15	24	●
248-P/M/K	24.8	13.9	3.77	10.13	24	●
249-P/M/K	24.9	13.9	3.78	10.12	24	●
250-P/M/K	25.0	14.5	3.80	10.70	25	●
251-P/M/K	25.1	14.5	3.82	10.68	25	●
252-P/M/K	25.2	14.5	3.84	10.66	25	●
253-P/M/K	25.3	14.5	3.85	10.65	25	●
254-P/M/K	25.4	14.5	3.87	10.63	25	●
255-P/M/K	25.5	14.5	3.89	10.61	25	●
256-P/M/K	25.6	14.5	3.91	10.59	25	●
257-P/M/K	25.7	14.5	3.93	10.57	25	●
258-P/M/K	25.8	14.5	3.95	10.55	25	●
259-P/M/K	25.9	14.5	3.96	10.54	25	●

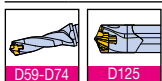

► Drill head can be ordered by an application
 Order example) Diameter 10.0mm drill head for
 ISO P application: TCD-100-P TT9080

●: Standard items

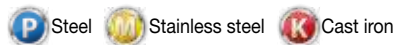

TCD...N



Drill heads for aluminum alloy

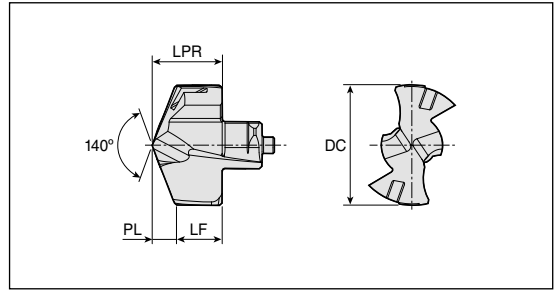

Designation	Dimension (mm)					Grade	
	DC	LPR	PL	LF	SSC	UF10	
TCD - 060-N	6.0	4.00	0.96	3.04	6	●	
065-N	6.5	4.30	1.18	3.12	6.5	●	
070-N	7.0	4.60	1.01	3.59	7	●	
075-N	7.5	4.60	1.10	3.50	7	●	
080-N	8.0	5.40	1.20	4.20	8	●	
085-N	8.5	5.40	1.29	4.11	8	●	
090-N	9.0	5.80	1.35	4.45	9	●	
095-N	9.5	5.80	1.44	4.36	9	●	
100-N	10.0	6.20	1.50	4.70	10	●	
105-N	10.5	6.20	1.59	4.61	10	●	
110-N	11.0	6.60	1.67	4.93	11	●	
115-N	11.5	6.60	1.76	4.84	11	●	
120-N	12.0	7.00	1.82	5.18	12	●	
125-N	12.5	7.00	1.91	5.09	12	●	
130-N	13.0	7.60	1.96	5.64	13	●	
135-N	13.5	7.60	2.05	5.55	13	●	
140-N	14.0	8.15	2.12	6.03	14	●	
145-N	14.5	8.15	2.21	5.94	14	●	
150-N	15.0	8.73	2.27	6.46	15	●	
155-N	15.5	8.73	2.36	6.37	15	●	
160-N	16.0	9.30	2.42	6.88	16	●	
165-N	16.5	9.30	2.51	6.79	16	●	
170-N	17.0	9.90	2.59	7.31	17	●	
175-N	17.5	9.90	2.68	7.22	17	●	
180-N	18.0	10.50	2.73	7.77	18	●	
185-N	18.5	10.50	2.82	7.68	18	●	
190-N	19.0	11.00	2.88	8.12	19	●	
195-N	19.5	11.00	2.97	8.03	19	●	

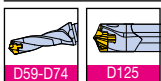

► SSC: Seat size code

●: Standard items

Nonferrous

Self-centering drill heads

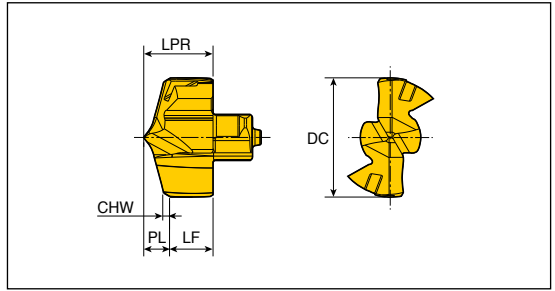

Designation	Dimension (mm)						Grade TT9080
	DC	LPR	PL	LF	CHW	SSC	
TCD-060-P+	6.0	4.00	1.46	2.54	0.5	6	●
065-P+	6.5	4.30	1.55	2.75	0.5	6.5	●
068-P+	6.8	4.30	1.59	2.71	0.5	6.5	●
070-P+	7.0	4.60	1.64	2.96	0.5	7	●
072-P+	7.2	4.60	1.67	2.93	0.5	7	●
075-P+	7.5	4.60	1.71	2.89	0.5	7	●
080-P+	8.0	5.40	1.81	3.59	0.5	8	●
081-P+	8.1	5.40	1.82	3.58	0.5	8	●
082-P+	8.2	5.40	1.84	3.56	0.5	8	●
083-P+	8.3	5.40	1.85	3.55	0.5	8	●
085-P+	8.5	5.40	1.88	3.52	0.5	8	●
086-P+	8.6	5.40	1.89	3.51	0.5	8	●
087-P+	8.7	5.40	1.90	3.50	0.5	8	●
088-P+	8.8	5.40	1.92	3.48	0.5	8	●
089-P+	8.9	5.40	1.93	3.47	0.5	8	●
090-P+	9.0	5.80	1.98	3.82	0.5	9	●
093-P+	9.3	5.80	2.02	3.78	0.5	9	●
095-P+	9.5	5.80	2.05	3.75	0.5	9	●
096-P+	9.6	5.80	2.06	3.74	0.5	9	●
097-P+	9.7	5.80	2.07	3.73	0.5	9	●
098-P+	9.8	5.80	2.09	3.71	0.5	9	●
099-P+	9.9	5.80	2.10	3.70	0.5	9	●
100-P+	10.0	6.20	2.33	3.87	0.7	10	●
101-P+	10.1	6.20	2.34	3.86	0.7	10	●
102-P+	10.2	6.20	2.36	3.84	0.7	10	●
103-P+	10.3	6.20	2.37	3.83	0.7	10	●
105-P+	10.5	6.20	2.40	3.80	0.7	10	●
106-P+	10.6	6.20	2.41	3.79	0.7	10	●
107-P+	10.7	6.20	2.42	3.78	0.7	10	●
108-P+	10.8	6.20	2.44	3.76	0.7	10	●
109-P+	10.9	6.20	2.45	3.75	0.7	10	●
110-P+	11.0	6.60	2.50	4.10	0.7	11	●
111-P+	11.1	6.60	2.51	4.09	0.7	11	●
112-P+	11.2	6.60	2.53	4.07	0.7	11	●
113-P+	11.3	6.60	2.54	4.06	0.7	11	●

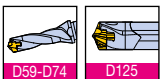

▶ SSC: Seat size code

●: Standard items

TCD-P+

Self-centering drill heads

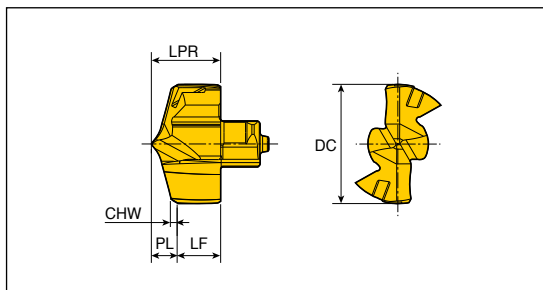

Designation	Dimension (mm)						Grade TT9080
	DC	LPR	PL	LF	CHW	SSC	
TCD-114-P+	11.4	6.60	2.55	4.05	0.7	11	●
115-P+	11.5	6.60	2.57	4.03	0.7	11	●
116-P+	11.6	6.60	2.58	4.02	0.7	11	●
117-P+	11.7	6.60	2.59	4.01	0.7	11	●
118-P+	11.8	6.60	2.61	3.99	0.7	11	●
119-P+	11.9	6.60	2.62	3.98	0.7	11	●
120-P+	12.0	7.00	2.67	4.33	0.7	12	●
121-P+	12.1	7.00	2.68	4.32	0.7	12	●
122-P+	12.2	7.00	2.70	4.30	0.7	12	●
123-P+	12.3	7.00	2.71	4.29	0.7	12	●
124-P+	12.4	7.00	2.72	4.28	0.7	12	●
125-P+	12.5	7.00	2.74	4.26	0.7	12	●
126-P+	12.6	7.00	2.75	4.25	0.7	12	●
127-P+	12.7	7.00	2.76	4.24	0.7	12	●
128-P+	12.8	7.00	2.78	4.22	0.7	12	●
130-P+	13.0	7.60	2.85	4.75	0.7	13	●
131-P+	13.1	7.60	2.86	4.74	0.7	13	●
132-P+	13.2	7.60	2.88	4.72	0.7	13	●
133-P+	13.3	7.60	2.89	4.71	0.7	13	●
134-P+	13.4	7.60	2.90	4.70	0.7	13	●
135-P+	13.5	7.60	2.92	4.68	0.7	13	●
136-P+	13.6	7.60	2.93	4.67	0.7	13	●
137-P+	13.7	7.60	2.94	4.66	0.7	13	●
138-P+	13.8	7.60	2.96	4.64	0.7	13	●
139-P+	13.9	7.60	2.97	4.63	0.7	13	●
140-P+	14.0	8.15	3.02	5.13	0.7	14	●
141-P+	14.1	8.15	3.03	5.12	0.7	14	●
142-P+	14.2	8.15	3.05	5.10	0.7	14	●
143-P+	14.3	8.15	3.06	5.09	0.7	14	●
144-P+	14.4	8.15	3.07	5.08	0.7	14	●
145-P+	14.5	8.15	3.09	5.06	0.7	14	●
146-P+	14.6	8.15	3.10	5.05	0.7	14	●
147-P+	14.7	8.15	3.11	5.04	0.7	14	●
148-P+	14.8	8.15	3.13	5.02	0.7	14	●
150-P+	15.0	8.73	3.19	5.54	0.7	15	●

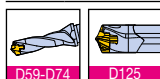

► SSC: Seat size code

●: Standard items

Self-centering drill heads

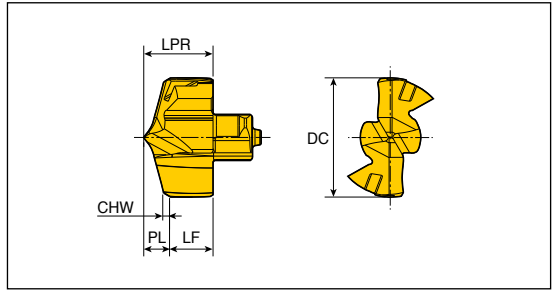

Designation	Dimension (mm)						Grade TT9080
	DC	LPR	PL	LF	CHW	SSC	
TCD-151-P+	15.1	8.73	3.20	5.53	0.7	15	●
152-P+	15.2	8.73	3.22	5.51	0.7	15	●
153-P+	15.3	8.73	3.23	5.50	0.7	15	●
154-P+	15.4	8.73	3.24	5.49	0.7	15	●
155-P+	15.5	8.73	3.26	5.47	0.7	15	●
156-P+	15.6	8.73	3.27	5.46	0.7	15	●
157-P+	15.7	8.73	3.28	5.45	0.7	15	●
158-P+	15.8	8.73	3.30	5.43	0.7	15	●
159-P+	15.9	8.73	3.31	5.42	0.7	15	●
160-P+	16.0	9.30	3.46	5.84	0.81	16	●
161-P+	16.1	9.30	3.47	5.83	0.81	16	●
162-P+	16.2	9.30	3.49	5.81	0.81	16	●
163-P+	16.3	9.30	3.50	5.80	0.81	16	●
164-P+	16.4	9.30	3.51	5.79	0.81	16	●
165-P+	16.5	9.30	3.53	5.77	0.81	16	●
166-P+	16.6	9.30	3.54	5.76	0.81	16	●
167-P+	16.7	9.30	3.55	5.75	0.81	16	●
168-P+	16.8	9.30	3.57	5.73	0.81	16	●
170-P+	17.0	9.90	3.63	6.27	0.81	17	●
171-P+	17.1	9.90	3.64	6.26	0.81	17	●
172-P+	17.2	9.90	3.66	6.24	0.81	17	●
173-P+	17.3	9.90	3.67	6.23	0.81	17	●
174-P+	17.4	9.90	3.68	6.22	0.81	17	●
175-P+	17.5	9.90	3.70	6.20	0.81	17	●
176-P+	17.6	9.90	3.71	6.19	0.81	17	●
177-P+	17.7	9.90	3.72	6.18	0.81	17	●
178-P+	17.8	9.90	3.74	6.16	0.81	17	●
179-P+	17.9	9.90	3.75	6.15	0.81	17	●
180-P+	18.0	10.50	3.81	6.69	0.81	18	●
181-P+	18.1	10.50	3.82	6.68	0.81	18	●
182-P+	18.2	10.50	3.84	6.66	0.81	18	●
183-P+	18.3	10.50	3.85	6.65	0.81	18	●
185-P+	18.5	10.50	3.88	6.62	0.81	18	●
186-P+	18.6	10.50	3.89	6.61	0.81	18	●
187-P+	18.7	10.50	3.90	6.60	0.81	18	●

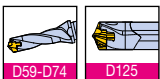

▶ SSC: Seat size code

●: Standard items

TCD-P+

Self-centering drill heads

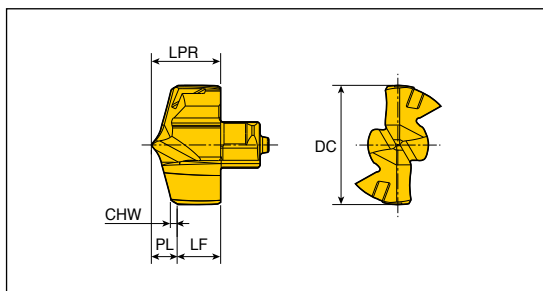

Designation	Dimension (mm)						Grade TT9080
	DC	LPR	PL	LF	CHW	SSC	
TCD-188-P+	18.8	10.50	3.92	6.58	0.81	18	●
190-P+	19.0	11.00	3.98	7.02	0.81	19	●
191-P+	19.1	11.00	3.99	7.01	0.81	19	●
192-P+	19.2	11.00	4.01	6.99	0.81	19	●
193-P+	19.3	11.00	4.02	6.98	0.81	19	●
194-P+	19.4	11.00	4.03	6.97	0.81	19	●
195-P+	19.5	11.00	4.05	6.95	0.81	19	●
196-P+	19.6	11.00	4.06	6.94	0.81	19	●
197-P+	19.7	11.00	4.07	6.93	0.81	19	●
198-P+	19.8	11.00	4.09	6.91	0.81	19	●
199-P+	19.9	11.00	4.10	6.90	0.81	19	●
200-P+	20.0	11.60	4.15	7.45	0.81	20	●
201-P+	20.1	11.60	4.16	7.44	0.81	20	●
202-P+	20.2	11.60	4.18	7.42	0.81	20	●
205-P+	20.5	11.60	4.22	7.38	0.81	20	●
206-P+	20.6	11.60	4.23	7.37	0.81	20	●
207-P+	20.7	11.60	4.24	7.36	0.81	20	●
210-P+	21.0	12.18	4.32	7.86	0.81	21	●
212-P+	21.2	12.18	4.35	7.83	0.81	21	●
213-P+	21.3	12.18	4.36	7.82	0.81	21	●
214-P+	21.4	12.18	4.37	7.81	0.81	21	●
215-P+	21.5	12.18	4.39	7.79	0.81	21	●
218-P+	21.8	12.18	4.43	7.75	0.81	21	●
220-P+	22.0	12.76	4.50	8.26	0.81	22	●
225-P+	22.5	12.76	4.57	8.19	0.81	22	●
229-P+	22.9	12.76	4.62	8.14	0.81	22	●
230-P+	23.0	13.33	4.67	8.66	0.81	23	●
235-P+	23.5	13.33	4.74	8.59	0.81	23	●
240-P+	24.0	13.90	4.84	9.06	0.81	24	●
245-P+	24.5	13.90	4.91	8.99	0.81	24	●
250-P+	25.0	14.50	5.01	9.49	0.81	25	●
254-P+	25.4	14.50	5.06	9.44	0.81	25	●
255-P+	25.5	14.50	5.08	9.42	0.81	25	●
256-P+	25.6	14.50	5.09	9.41	0.81	25	●
257-P+	25.7	14.50	5.10	9.40	0.81	25	●

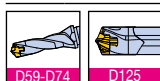

► SSC: Seat size code

●: Standard items

Drill heads for flat bottom hole

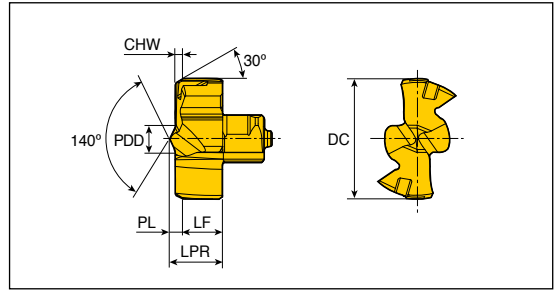

Designation	Dimension (mm)							Grade
	DC	PDD	LPR	PL	LF	CHW	SSC	TT9080
TCD - 080-F	8.0	2.33	4.4	1.09	3.3	0.7	8	●
085-F	8.5	2.33	4.4	1.09	3.3	0.7	8	●
090-F	9.0	2.29	4.6	1.11	3.5	0.7	9	●
095-F	9.5	2.29	4.6	1.11	3.5	0.7	9	●
100-F	10.0	2.44	4.9	1.17	3.7	0.7	10	●
105-F	10.5	2.44	4.9	1.17	3.7	0.7	10	●
110-F	11.0	3.09	5.1	1.25	3.8	0.7	11	●
115-F	11.5	3.09	5.1	1.25	3.8	0.7	11	●
120-F	12.0	2.95	5.4	1.26	4.1	0.7	12	●
125-F	12.5	2.95	5.4	1.26	4.1	0.7	12	●
130-F	13.0	3.04	5.7	1.30	4.4	0.7	13	●
135-F	13.5	3.04	5.7	1.30	4.4	0.7	13	●
140-F	14.0	3.30	6.1	1.31	4.8	0.7	14	●
145-F	14.5	3.30	6.1	1.31	4.8	0.7	14	●
150-F	15.0	3.54	6.6	1.35	5.23	0.7	15	●
155-F	15.5	3.54	6.6	1.35	5.23	0.7	15	●
160-F	16.0	3.74	7.0	1.39	5.6	0.7	16	●
165-F	16.5	3.74	7.0	1.39	5.6	0.7	16	●
170-F	17.0	3.75	7.3	1.40	5.9	0.7	17	●
175-F	17.5	3.75	7.3	1.40	5.9	0.7	17	●
180-F	18.0	3.85	7.6	1.42	6.18	0.7	18	●
185-F	18.5	3.85	7.6	1.42	6.18	0.7	18	●
190-F	19.0	3.86	7.9	1.44	6.5	0.7	19	●
195-F	19.5	3.86	7.9	1.44	6.5	0.7	19	●
200-F	20.0	6.76	9.3	1.77	7.5	0.7	20	●
205-F	20.5	6.76	9.3	1.77	7.5	0.7	20	●
210-F	21.0	6.98	9.7	1.79	7.9	0.7	21	●
215-F	21.5	6.98	9.7	1.79	7.9	0.7	21	●
220-F	22.0	7.42	10.0	1.81	8.2	0.7	22	●
225-F	22.5	7.42	10.0	1.81	8.2	0.7	22	●
230-F	23.0	7.60	10.4	1.83	8.6	0.7	23	●
235-F	23.5	7.60	10.4	1.83	8.6	0.7	23	●
240-F	24.0	8.13	10.9	1.86	9.0	0.7	24	●
245-F	24.5	8.13	10.9	1.86	9.0	0.7	24	●
250-F	25.0	8.16	11.3	1.89	9.4	0.7	25	●

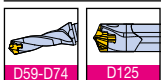

► SSC: Seat size code

●: Standard items

Chamfering inserts for pre-thread hole

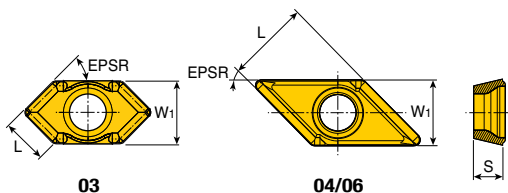

Size	Dimension (mm)			
	W1	L	S	EPSR
03-C30	4.0	4.00	1.59	30
03-C45	4.0	2.80	1.59	45
04-C45	3.6	5.20	1.80	45
06-C45	4.5	5.66	1.96	45

Insert	Designation	Coated						Uncoated	
		TT9080	TT9030	TT8020	TT6030	TT9300	TT7400		
	AOMT 030204-C30	●						K10	
	030204-C45	●							
	AOMT 040204-C45	●							
	060204-C45	●							



●: Standard items

CRNG 0802-45CD

Chamfering inserts for chamfering ring

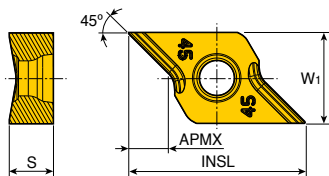

Size	Dimension (mm)			
	W1	INSL	S	APMX
08	7.5	14.80	3.65	3.3

Insert	Designation	Coated						Uncoated	
		TT9080	TT9030	TT8020	TT6030	TT9300	TT7400		
	CRNG 0802-45CD	●						K10	



●: Standard items

TCD...P-CO+

Drill heads

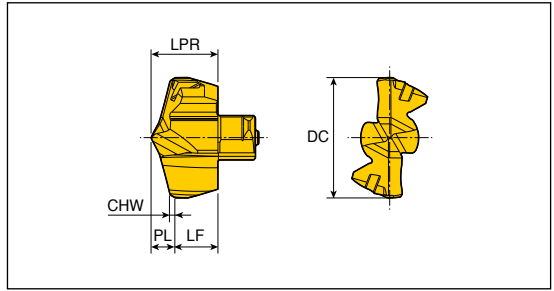

Designation	Dimension (mm)						Grade
	DC	LPR	PL	LF	CHW	SSC	TT9080
TCD-159-P-CO+	15.9	8.73	3.17	5.56	0.7	15	●
169-P-CO+	16.9	9.30	3.34	5.96	0.81	16	●
179-P-CO+	17.9	9.90	3.50	6.40	0.81	17	●
189-P-CO+	18.9	10.50	3.66	6.84	0.81	18	●
199-P-CO+	19.9	11.00	3.82	7.18	0.81	19	●
209-P-CO+	20.9	11.60	3.98	7.62	0.81	20	●
219-P-CO+	21.9	12.18	4.15	8.03	0.81	21	●
229-P-CO+	22.9	12.76	4.31	8.45	0.81	22	●
239-P-CO+	23.9	13.33	4.48	8.85	0.81	23	●
249-P-CO+	24.9	13.90	4.64	9.26	0.81	24	●
259-P-CO+	25.9	14.50	4.81	9.69	0.81	25	●



► SSC: Seat size code

●: Standard items

SPGX...DW

Inserts

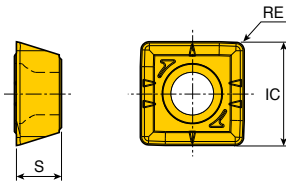

Size	Dimension (mm)			
	IC	S	RE	
06	6.07	2.38	0.4	
07	8.02	3.97	0.8	
09	9.91	4.30	0.8	
11	11.62	4.80	0.8	
14	14.41	5.20	1.2	

Insert	Designation	Coated						Uncoated	
		TT9080	TT8020	TT9300	TT9030	TT6030	TT7400	K10	
	SPGX 060204 DW	●							
	07T308 DW	●							
	090408 DW	●							
	110408 DW	●							
	140512 DW	●							



●: Standard items

Drill heads

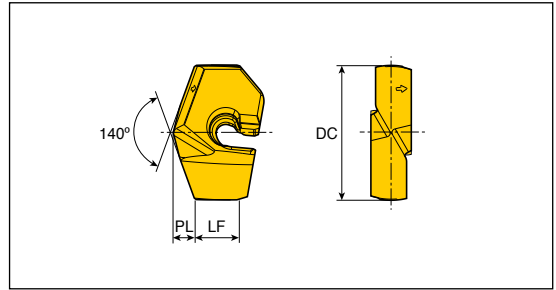

Designation	Dimension (mm)				Grade TT9080
	DC	PL	LF	SSC	
LCD- 200-P	20.0	3.11	6.54	20	●
205-P	20.5	3.20	6.45	20	●
210-P	21.0	3.29	6.36	21	●
215-P	21.5	3.38	6.27	21	●
220-P	22.0	3.42	7.12	22	●
225-P	22.5	3.51	7.03	22	●
230-P	23.0	3.60	6.94	23	●
235-P	23.5	3.69	6.85	23	●
240-P	24.0	3.73	7.03	24	●
245-P	24.5	3.82	6.94	24	●
250-P	25.0	3.91	6.85	25	●
255-P	25.5	4.00	6.76	25	●
260-P	26.0	4.04	7.51	26	●
265-P	26.5	4.13	7.42	26	●
270-P	27.0	4.22	7.33	27	●
275-P	27.5	4.31	7.24	27	●
280-P	28.0	4.35	7.39	28	●
285-P	28.5	4.44	7.30	28	●
290-P	29.0	4.53	7.21	29	●
295-P	29.5	4.62	7.12	29	●
300-P	30.0	4.67	9.47	30	●
305-P	30.5	4.76	9.38	30	●
310-P	31.0	4.85	9.29	31	●
315-P	31.5	4.94	9.20	31	●
320-P	32.0	4.98	9.55	32	●
325-P	32.5	5.07	9.46	32	●
330-P	33.0	5.16	9.37	33	●
335-P	33.5	5.25	9.28	33	●
340-P	34.0	5.34	9.19	34	●
345-P	34.5	5.44	9.10	34	●
350-P	35.0	5.44	11.12	35	●
355-P	35.5	5.53	11.03	35	●
360-P	36.0	5.62	10.94	36	●
365-P	36.5	5.71	10.85	36	●
370-P	37.0	5.80	10.76	37	●



► SSC: Seat size code

●: Standard items

LCD...-P+

Self-centering drill head

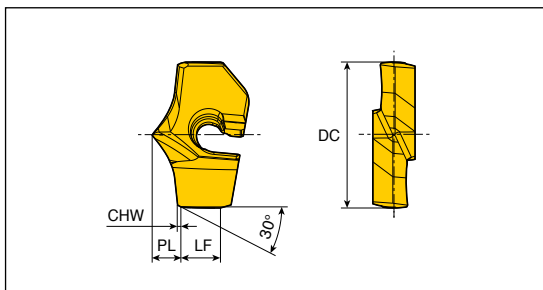

Designation	Dimension (mm)					Grade
	DC	PL	LF	CHW	SSC	
LCD- 200-P+	20.0	4.55	5.83	0.86	20	●
205-P+	20.5	4.58	5.60	0.86	20	●
210-P+	21.0	4.60	5.36	0.86	21	●
215-P+	21.5	4.63	5.13	0.86	21	●
220-P+	22.0	4.92	6.21	0.86	22	●
225-P+	22.5	4.95	5.98	0.86	22	●
230-P+	23.0	4.97	5.74	0.86	23	●
235-P+	23.5	5.00	5.51	0.86	23	●
240-P+	24.0	5.30	5.93	0.86	24	●
245-P+	24.5	5.33	5.70	0.86	24	●
250-P+	25.0	5.35	5.46	0.86	25	●
255-P+	25.5	5.38	5.23	0.86	25	●
260-P+	26.0	5.67	7.39	0.86	26	●
265-P+	26.5	5.70	7.16	0.86	26	●
270-P+	27.0	5.72	6.92	0.86	27	●
275-P+	27.5	5.75	6.69	0.86	27	●
280-P+	28.0	5.73	7.26	0.86	28	●
285-P+	28.5	5.76	7.03	0.86	28	●
290-P+	29.0	5.78	6.79	0.86	29	●
295-P+	29.5	5.81	6.56	0.86	29	●
300-P+	30.0	6.08	9.17	0.86	30	●
305-P+	30.5	6.11	8.94	0.86	30	●
310-P+	31.0	6.13	8.70	0.86	31	●
315-P+	31.5	6.16	8.47	0.86	31	●
320-P+	32.0	6.43	9.18	0.86	32	●
325-P+	32.5	6.46	8.95	0.86	32	●
330-P+	33.0	6.48	8.71	0.86	33	●
335-P+	33.5	6.51	8.48	0.86	33	●
340-P+	34.0	6.53	8.24	0.86	34	●
345-P+	34.5	6.56	8.01	0.86	34	●



► SSC: Seat size code

●: Standard items

Drill heads for flat bottom hole

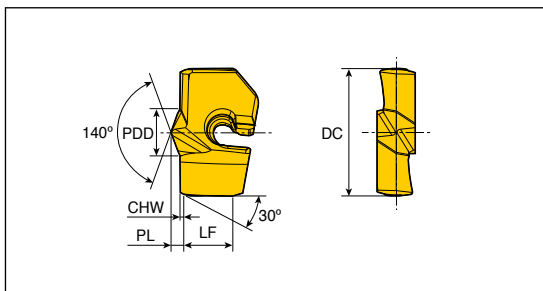

Designation	Dimension (mm)						Grade
	DC	PL	LF	CHW	SSC	PDD	TT9080
LCD - 200-F	20.0	2.18	7.63	0.7	20	8.3	●
205-F	20.5	2.18	7.63	0.7	20	8.3	●
210-F	21.0	2.18	7.63	0.7	21	8.3	●
215-F	21.5	2.18	7.63	0.7	21	8.3	●
220-F	22.0	2.38	8.17	0.7	22	9.0	●
225-F	22.5	2.38	8.17	0.7	22	9.0	●
230-F	23.0	2.38	8.17	0.7	23	9.0	●
235-F	23.5	2.38	8.17	0.7	23	9.0	●
240-F	24.0	2.52	8.10	0.7	24	10.0	●
245-F	24.5	2.52	8.10	0.7	24	10.0	●
250-F	25.0	2.52	8.10	0.7	25	10.0	●
255-F	25.5	2.52	8.10	0.7	25	10.0	●
260-F	26.0	2.48	9.84	0.7	26	10.5	●
265-F	26.5	2.48	9.84	0.7	26	10.5	●
270-F	27.0	2.48	9.84	0.7	27	10.5	●
275-F	27.5	2.48	9.84	0.7	27	10.5	●
280-F	28.0	2.72	9.50	0.7	28	11.6	●
285-F	28.5	2.72	9.50	0.7	28	11.6	●
290-F	29.0	2.72	9.50	0.7	29	11.6	●
295-F	29.5	2.72	9.50	0.7	29	11.6	●
300-F	30.0	2.80	11.63	0.7	30	12.4	●
305-F	30.5	2.80	11.63	0.7	30	12.4	●
310-F	31.0	2.80	11.63	0.7	31	12.4	●
315-F	31.5	2.80	11.63	0.7	31	12.4	●
320-F	32.0	3.13	11.59	0.7	32	13.6	●
325-F	32.5	3.13	11.59	0.7	32	13.6	●
330-F	33.0	3.13	11.59	0.7	33	13.6	●
335-F	33.5	3.13	11.59	0.7	33	13.6	●
340-F	34.0	3.13	11.59	0.7	34	13.6	●
345-F	34.5	3.13	11.59	0.7	34	13.6	●
350-F	35.0	3.31	13.20	0.7	35	14.6	●
355-F	35.5	3.31	13.20	0.7	35	14.6	●
360-F	36.0	3.31	13.20	0.7	36	14.6	●
365-F	36.5	3.31	13.20	0.7	36	14.6	●
370-F	37.0	3.31	13.20	0.7	37	14.6	●



▶ SSC: Seat size code

●: Standard items



XCGT ...-C

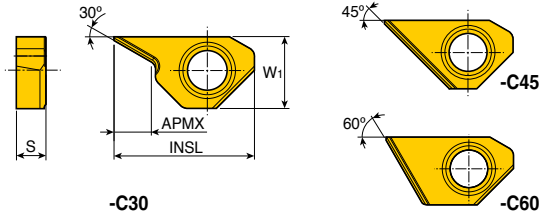

Chamfering inserts for T-CHAMFER holder



Size	Dimension (mm)			
	W1	INSL	S	APMX
06-C30	6.18	12.3	2.8	3.49
09-C30	8.50	16.0	3.3	4.43
06-C45	6.18	12.3	2.8	5.89
09-C45	8.50	16.0	3.3	8.07
06-C60	6.18	12.3	2.8	3.43
09-C60	8.50	16.0	3.3	4.78

Insert	Designation	Coated						Uncoated	
		TT9080	TT9030	TT8020	TT6030	TT9300	TT7400		K10
	XCGT 0603-C30	•							
	0903-C30	•							
	XCGT 0603-C45	•							
	0903-C45	•							
	XCGT 0603-C60	•							
	0903-C60	•							

• Standard items



XCGT...TA



Inserts

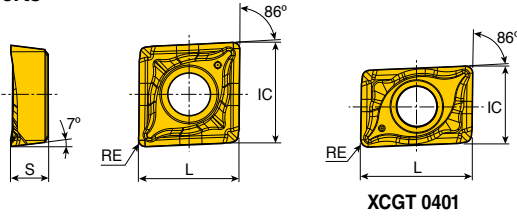

Size	Dimension (mm)			
	IC	L	S	RE
04	4.4	6.4	1.70	0.4
05	5.6	5.6	2.10	0.4
06	6.4	6.4	2.38	0.4
07	7.5	7.5	3.18	0.4
08	8.4	8.4	3.18	0.4
10	10.5	10.5	3.97	0.4
13	13.4	13.4	4.76	0.4
17	17.5	17.5	5.56	0.8

XCGT 0401

• For aluminum alloy

Insert	Designation	Turning		Drilling	Coated					Uncoated		
		ap (mm)	Feed (mm/rev)	Feed (mm/rev)	TT9080	TT8020	TT9300	TT9030	TT6030	TT7400	K10	
<p>Right hand shown (XCGT 0401)</p>	XCGT 040104R TA	0.2-1.8	0.02-0.15	0.02-0.09							•	
	040104L TA	0.2-1.8	0.02-0.15	0.02-0.09							•	
	050204 TA	0.2-2.2	0.03-0.18	0.02-0.11							•	
	060204 TA	0.3-2.5	0.03-0.20	0.03-0.12							•	
	070304 TA	0.4-2.8	0.05-0.22	0.03-0.13							•	
	080304 TA	0.4-3.2	0.06-0.25	0.03-0.13							•	
	10T304 TA	0.5-3.5	0.06-0.30	0.03-0.13							•	
	130404 TA	0.6-4.3	0.08-0.33	0.03-0.13							•	
	170508 TA	0.7-5.3	0.10-0.38	0.03-0.13							•	



•: Standard items

XCMT..R-GV



Inserts

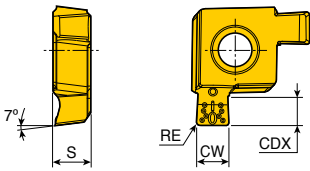

Size	Dimension (mm)			
	CW	CDX	S	RE
05	2.0	1.8	2.27	0.2
06	2.0	2.0	2.62	0.2
07	2.5	2.0	3.42	0.2
08	2.5	2.5	3.50	0.2
10	3.0	3.0	4.37	0.3
13	3.5	3.5	5.24	0.3
17	4.0	4.0	6.06	0.4

• For grooving

Insert	Designation	Coated						Uncoated	
		TT9080	TT8020	TT9300	TT9030	TT6030	TT7400	K10	
	XCMT 05R-200020GV	•	•						
	06R-200020GV	•	•						
	07R-250020GV	•	•						
	08R-250020GV	•	•						
	10R-300030GV	•	•						
	13R-350030GV	•	•						
	17R-400040GV	•	•						



► Grooving insert is available only for right handed type

•: Standard items

NPMX...R-B/R-G



Inserts for TBTA...3/5/7/9

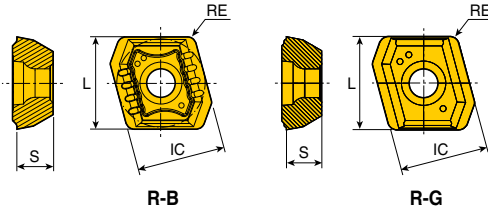

Size	Dimension (mm)			
	IC	L	S	RE
08	8.0	8.36	3.18	0.8

Insert	Designation	Pocket			Coated					Uncoated		
		Center	Inner	Outer	TT9030	TT8125	TT7200	TT6130	TT6020	TT5100	TT5030	K10
	NPMX 080308R-B	●	●	●	●	●		●				
	080308R-G	●	●	●	●	●			●	●		



●: Standard items

TPMX...R-B/R-G



Inserts for TBTA...3/5/7/9 & TBTA-R

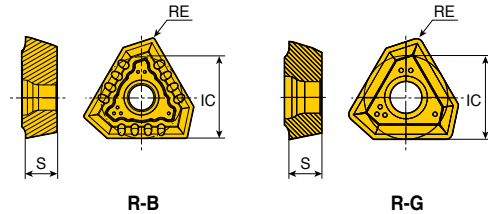

Size	Dimension (mm)		
	IC	S	RE
140304 R-B	8.45	3.5	0.4
140308 R-B/R-G	8.45	3.5	0.8
170404 R-B	10.30	4.0	0.4
170408 R-B/R-G	10.30	4.0	0.8
240504 R-B	14.20	5.5	0.4
240512 R-B/R-G	14.20	5.5	1.2
280708 R-B	17.00	7.5	0.8
280716 R-B/R-G	17.00	7.5	1.6

Insert	Designation	Pocket			Coated					Uncoated			
		Center	Inner	Outer	TT9030	TT9130	TT8125	TT7200	TT6130	TT6020	TT5100	TT5030	K10
	TPMX 140304R-B	●	●	●	●		●						
	140308R-B	●	●	●		●						●	
	140308R-G	●	●	●	●	●	●	●		●	●	●	
	170404R-B	●	●	●	●		●		●				
	170408R-B	●	●	●		●						●	
	170408R-G	●	●	●	●	●	●	●		●	●	●	
	240504R-B	●	●	●	●		●		●				
	240512R-B	●	●	●		●						●	
	240512R-G	●	●	●	●	●	●	●		●	●	●	
	280708R-B	●	●	●	●				●				
	280716R-B	●	●	●	●	●						●	
280716R-G	●	●	●	●	●	●	●		●	●	●		



●: Standard items

ZSGT



Deep drilling inserts with single chip splitting cutting edge and a wiper for high hole surface quality

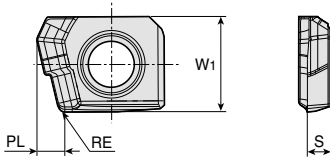

Size	Dimension (mm)			
	W1	RE	PL	S
06	6.00	0.40	1.80	1.50

Insert	Designation	Coated							Uncoated		
		TT9030	TT9130	TT8125	TT7200	TT6130	TT6020	TT5100	TT5030	K10	
	ZSGT 060204R-RS		●								



●: Standard items

LOGT



Deep drilling inserts with 2 chip splitting cutting edges, positive rake chipbreaker and a wiper for high hole surface quality

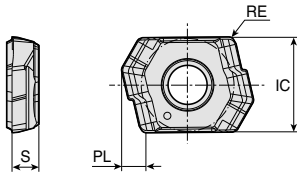

Size	Dimension (mm)			
	IC	RE	PL	S
06	7.00	0.40	1.80	2.00

Insert	Designation	Coated							Uncoated		
		TT9030	TT9130	TT8125	TT7200	TT6130	TT6020	TT5100	TT5030	K10	
	LOGT 060204R-RS		●	●							



●: Standard items

D127, D131

TPMX...LG



Inserts for TBTA-R

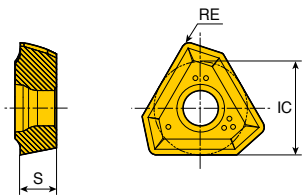

Size	Dimension (mm)			
	IC	S	RE	
14	8.45	3.5	0.8	
17	10.30	4.0	0.8	
24	14.20	5.5	1.2	

Insert	Designation	Pocket			Coated						Uncoated			
		Center	Inner	Outer	TT9030	TT9130	TT8125	TT7200	TT6130	TT6020	TT5100	TT5030	K10	
	TPMX 140308 LG			•	•						•			
	170408 LG			•	•	•				•	•			
	240512 LG			•	•	•				•	•			



•: Standard items

XPMT...-45



Inserts for TBTA-R

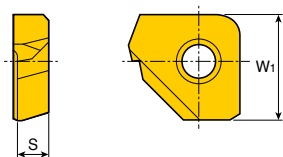

Size	Dimension (mm)		
	W1	S	
16	9.5	2.70	

Insert	Designation	Pocket			Coated						Uncoated		
		Center	Inner	Outer	TT9030	TT8125	TT7100	TT3500	TT6020	TT9300	TT7400	K10	
	XPMT 16002-45			•	•								



•: Standard items

Pad for TBTA 3.../5.../7.../9...

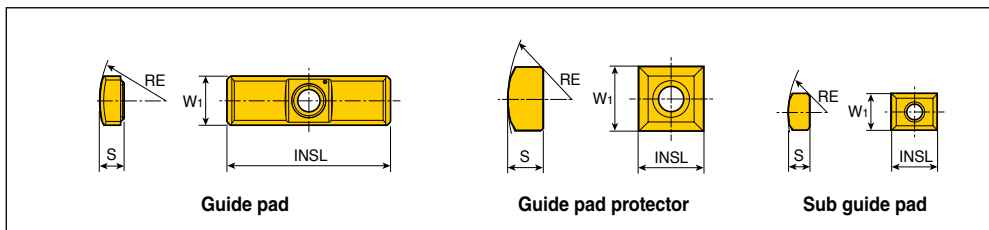

Designation	Dimension (mm)				Screw	
	W1	S	INSL	RE		
Guide pad	PAD - GP08-25-155-DC-SB	8	4.5	25	15.5	CSTB3S
	GP08-25-155-DC-SC	8	4.5	25	15.5	CSTB3S
	GP10-35-200-DC-SB	10	6.0	35	20.0	CSTB4S
	GP10-35-200-DC-SC	10	6.0	35	20.0	CSTB4S
	GP14-40-250-DC-SB/SC	14	7.5	40	25.0	CSTA5S
	GP18-40-300-DC-SB/SC	18	9.0	40	30.0	LS1206S
Guide pad protector	PAD - P08	8	4.5	8	17.5	CSTB3S
	P10	10	6.0	10	20.0	CSTB4S
	P14	14	7.5	14	25.0	CSTA5S
	P18	18	9.0	18	30.0	LS1206S
	Sub guide pad	PAD - S08	8	4.5	10	17.5
S10		10	5.0	10	29.0	CSTB3S
S14		14	7.0	20	45.0	CCSTA5S



Plus Guide Pad for TBTA 3.../5.../7.../9...

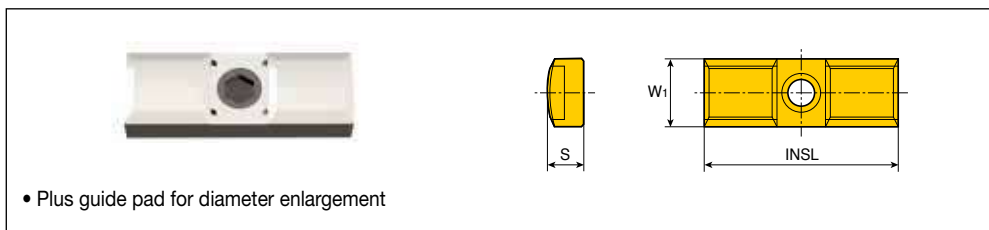

Designation								
DC	PAD-GC08	S	PAD-GC10	S	PAD-GC14	S	PAD-GC18	S
DC+1mm	PAD-GC08-DC+1	5.0	PAD-GC10-DC+1	6.5	PAD-GC14-DC+1	8.0	PAD-GC18-DC+1	9.5
DC+2mm	PAD-GC08-DC+2	5.5	PAD-GC10-DC+2	7.0	PAD-GC14-DC+2	8.5	PAD-GC18-DC+2	10.0
DC+3mm	PAD-GC08-DC+3	6.0	PAD-GC10-DC+3	7.5	PAD-GC14-DC+3	9.0	PAD-GC18-DC+3	10.5
DC+4mm	-	-	PAD-GC10-DC+4	8.0	PAD-GC14-DC+4	9.5	PAD-GC18-DC+4	11.0
DC+5mm	-	-	-	-	PAD-GC14-DC+5	10.0	PAD-GC18-DC+5	11.5



Cartridge for TBTA 3.../5.../7.../9

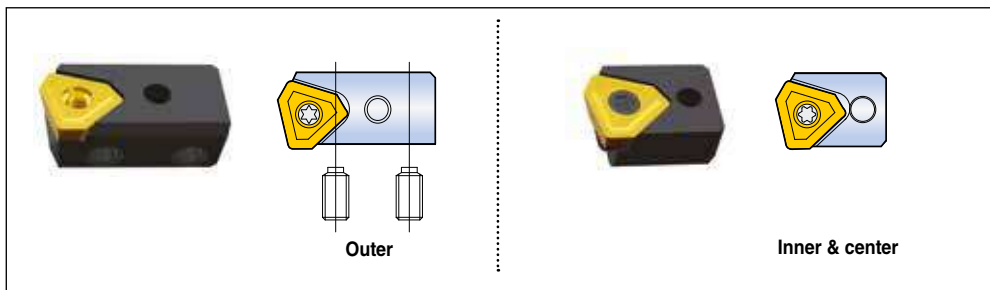

	Designation	Adjust screw	Wrench	Lock screw	Wrench	Insert
Outer	PERC 05R	AS0003-5	H1.5	LS1803RH	H2	NPMX0803..
	402-04	AS0004-8	H2	LS1803.5RH	H2.5	TPMX1403..
	402-32	AS0005-10	H2.5	LS1805RH	H3	TPMX1704..
	402-43	AS0005-15	H2.5	L1806RH	H4	TPMX2405..
	402-63	AS0006-15	H3	L1806RH	H4	TPMX2807..
Inner & center	CENC 05R	-	-	CSTB3	T9	NPMX0803..
	402-04	-	-	CSTB3.5	T15	TPMX1403..
	402-32	-	-	CSTA5	T15	TPMX1704..
	402-43	-	-	LS1206	H3	TPMX2405..
	402-63	-	-	LS1206	H3	TPMX2807..



Plus Cartridge for TBTA 3.../5.../7.../9



Designation					
DC	DC+1mm	DC+2mm	DC+3mm	DC+4mm	DC+5mm
PERC 05R	PERC 05R+1	PERC 05R+2	-	-	-
PERC 402-04	PERC 402-04+1	PERC 402-04+2	PERC 402-04+3	-	-
PERC 402-32	PERC 402-32+1	PERC 402-32+2	PERC 402-32+3	PERC 402-32+4	-
PERC 402-43	PERC 402-43+1	PERC 402-43+2	PERC 402-43+3	PERC 402-43+4	PERC 402-43+5
PERC 402-63	PERC 402-63+1	PERC 402-63+2	PERC 402-63+3	PERC 402-63+4	PERC 402-63+5



Cartridge for TBTA-R

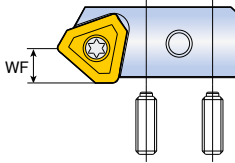

Accurate tolerance applications

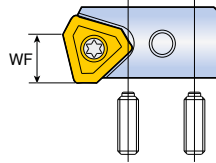

Open tolerance applications

Designation		WF (mm)	Adjust screw	Wrench	Lock screw	Wrench	Insert
Accurate tolerance applications	PERC P04R	5	AS0004-8	H2	LS1803.5RH	H2.5	TPMX1403..LG
	P32R	6	AS0005-10	H2.5	LS1805RH	H3	TPMX1704..LG
	P43R	8	AS0005-15	H2.5	LS1806RH	H4	TPMX2405..LG
Open tolerance applications	PERC 402-04	8	AS0004-8	H2	LS1803.5RH	H2.5	TPMX1403..RG
	402-32	9	AS0005-10	H2.5	LS1805RH	H3	TPMX1704..RG
	402-43	13	AS0005-15	H2.5	LS1806RH	H4	TPMX2405..RG



► PERC-P and PERC 402-□□ cartridges are interchangeable in the same pocket

D156-D161

Guide pad for TNDH-TP

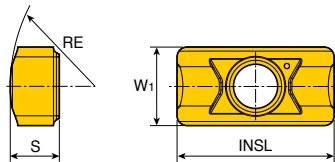

Designation	Dimension (mm)				Screw	Grade TT9030
	W1	S	INSL	RE		
PAD-G04-08	4	2.5	8	9	TS 20043I/HG-P	●



► Guide pad is sold separately from drill heads

●: Standard items

D75-D76

Recommended Cutting Conditions



Machining data for TOP-DRILL 2,3,4xD

ISO	Material	Condition	Tensile strength (N/mm ²)	Hardness HB	Material No.	Cutting speed Vc (m/min)	
P	Non-alloy steel, cast steel, free cutting steel	<0.25%C	Annealed	420	125	1	220-350
		>=0.25%C	Annealed	650	190	2	180-280
		<0.55%C	Quenched and tempered	850	250	3	140-240
		>=0.55%C	Annealed	750	220	4	140-240
			Quenched and tempered	1000	300	5	140-240
	Low alloy steel and cast steel (Less than 5% of alloying elements)	Quenched and tempered	Annealed	600	200	6	140-240
			930	275	7	100-180	
			1000	300	8	100-180	
			1200	350	9	100-180	
	High alloy steel, cast steel and tool steel	Annealed	680	200	10	140-200	
		Quenched and tempered	1100	325	11	100-160	
M	Stainless steel and cast steel	Ferritic / martensitic	680	200	12	150-250	
		Martensitic	820	240	13	150-250	
		Austenitic	600	180	14	150-250	
K	Gray cast iron (GG)	Ferritic		160	15	160-260	
		Pearlitic		250	16	160-260	
	Cast iron nodular (GGG)	Ferritic		180	17	160-260	
		Pearlitic		260	18	160-260	
	Malleable cast iron	Ferritic		130	19	120-220	
Pearlitic			230	20	120-220		
N	Aluminum - Wrought alloy	Not cureable		60	21	200-350	
		Cured		100	22	200-350	
	Aluminum-cast, alloyed	<=12% Si	Not cureable		75	23	200-350
			Cured		90	24	200-350
		>12% Si	High temp.		130	25	200-350
	Copper alloys	>1% Pb	Free cutting		110	26	150-250
		Brass			90	27	150-250
			Electrolytic copper		100	28	150-250
	Non-metallic		Duroplastics, fiber plastics		70 Shore D	29	150-250
			Hard rubber		55 Shore D	30	150-250
S	High temp. alloys	Fe based	Annealed		200	31	30-60
			Cured		280	32	30-60
		Ni or Co based	Annealed		250	33	30-60
			Cured		350	34	30-60
			Cast		320	35	30-60
	Titanium, Ti alloys	Pure	Rm 400	190	36	50-80	
Alpha+beta alloys cured		Rm 1050	310	37	50-80		
H	Hardened steel	Hardened		55HRC	38	30-60	
		Hardened		60HRC	39	30-60	
	Chilled cast iron	Cast		400	40	30-60	
	Cast iron nodular	Hardened		55HRC	41	30-60	

► For more information of material groups, see the materials & grades "material conversion table"

■ Steel
 ■ Stainless steel
 ■ Cast iron
 ■ Nonferrous
 ■ High temp. alloys
 ■ Hardened steel

Recommended Cutting Conditions



Machining data for TOP-DRILL 2,3,4xD

Feed (mm/rev) vs. drill diameter Drill length 2,3,4xD								
SOMT 04 Ø12 - Ø13.5	SOMT 05 Ø14 - Ø16	SOMT 06 Ø17 - Ø19	SOMT 07 Ø20 - Ø22	SOMT 08 Ø23 - Ø26	SOMT 09 Ø27 - Ø31	SOMT 11 Ø32 - Ø36	SOMT 13 Ø37 - Ø43	SOMT 15 Ø44 - Ø50
0.04-0.06	0.04-0.06	0.04-0.06	0.04-0.08	0.04-0.08	0.06-0.10	0.06-0.10	0.08-0.12	0.08-0.12
0.06-0.10	0.06-0.10	0.06-0.10	0.06-0.12	0.06-0.12	0.08-0.14	0.08-0.14	0.08-0.16	0.10-0.16
0.08-0.12	0.08-0.12	0.08-0.12	0.08-0.16	0.08-0.16	0.10-0.16	0.10-0.16	0.10-0.18	0.10-0.18
0.08-0.12	0.08-0.12	0.08-0.12	0.08-0.16	0.08-0.16	0.10-0.16	0.10-0.16	0.10-0.18	0.10-0.18
0.08-0.12	0.08-0.12	0.08-0.12	0.08-0.16	0.08-0.16	0.10-0.16	0.10-0.16	0.10-0.18	0.10-0.18
0.06-0.16	0.06-0.16	0.06-0.16	0.08-0.20	0.08-0.20	0.08-0.20	0.10-0.22	0.10-0.22	0.10-0.24
0.06-0.16	0.06-0.16	0.06-0.16	0.08-0.20	0.08-0.20	0.08-0.20	0.08-0.22	0.10-0.22	0.10-0.22
0.06-0.16	0.06-0.16	0.06-0.16	0.08-0.20	0.08-0.20	0.08-0.20	0.08-0.22	0.10-0.22	0.10-0.22
0.06-0.16	0.06-0.16	0.06-0.16	0.08-0.20	0.08-0.20	0.08-0.20	0.08-0.22	0.10-0.22	0.10-0.22
0.06-0.12	0.06-0.12	0.06-0.12	0.08-0.16	0.08-0.16	0.08-0.18	0.08-0.20	0.10-0.20	0.10-0.20
0.06-0.12	0.06-0.12	0.06-0.12	0.08-0.16	0.08-0.16	0.08-0.18	0.08-0.20	0.10-0.20	0.10-0.20
0.06-0.12	0.06-0.12	0.06-0.12	0.06-0.16	0.06-0.16	0.08-0.18	0.08-0.20	0.10-0.20	0.10-0.20
0.06-0.12	0.06-0.12	0.06-0.12	0.06-0.16	0.06-0.16	0.08-0.18	0.08-0.20	0.10-0.20	0.10-0.20
0.08-0.18	0.08-0.18	0.08-0.18	0.10-0.20	0.10-0.20	0.10-0.20	0.10-0.20	0.10-0.22	0.10-0.22
0.08-0.18	0.08-0.18	0.08-0.18	0.10-0.20	0.10-0.20	0.10-0.20	0.10-0.20	0.10-0.22	0.10-0.22
0.08-0.18	0.08-0.18	0.08-0.18	0.10-0.20	0.10-0.20	0.10-0.20	0.10-0.20	0.10-0.22	0.10-0.22
0.08-0.18	0.08-0.18	0.08-0.18	0.10-0.20	0.10-0.20	0.10-0.20	0.10-0.20	0.10-0.22	0.10-0.22
0.08-0.14	0.08-0.14	0.08-0.14	0.10-0.16	0.10-0.16	0.10-0.16	0.10-0.18	0.10-0.18	0.10-0.18
0.08-0.14	0.08-0.14	0.08-0.14	0.10-0.16	0.10-0.16	0.10-0.16	0.10-0.18	0.10-0.18	0.10-0.18
0.06-0.15	0.06-0.15	0.06-0.15	0.08-0.16	0.08-0.16	0.08-0.18	0.08-0.18	0.10-0.18	0.10-0.18
0.06-0.15	0.06-0.15	0.06-0.15	0.08-0.16	0.08-0.16	0.08-0.18	0.08-0.18	0.10-0.18	0.10-0.18
0.06-0.15	0.06-0.15	0.06-0.15	0.08-0.16	0.08-0.16	0.08-0.18	0.08-0.18	0.10-0.18	0.10-0.18
0.06-0.15	0.06-0.15	0.06-0.15	0.08-0.16	0.08-0.16	0.08-0.18	0.08-0.18	0.10-0.18	0.10-0.18
0.06-0.15	0.06-0.15	0.06-0.15	0.08-0.16	0.08-0.16	0.08-0.18	0.08-0.18	0.10-0.18	0.10-0.18
0.06-0.15	0.06-0.15	0.06-0.15	0.08-0.16	0.08-0.16	0.08-0.18	0.08-0.17	0.10-0.18	0.10-0.18
0.06-0.15	0.06-0.15	0.06-0.15	0.08-0.16	0.08-0.16	0.08-0.18	0.08-0.17	0.10-0.18	0.10-0.18
0.06-0.15	0.06-0.15	0.06-0.15	0.08-0.16	0.08-0.16	0.08-0.18	0.08-0.17	0.10-0.18	0.10-0.18
0.06-0.15	0.06-0.15	0.06-0.15	0.08-0.16	0.08-0.16	0.10-0.17	0.10-0.17	0.10-0.18	0.10-0.18
0.06-0.15	0.06-0.15	0.06-0.15	0.08-0.16	0.08-0.16	0.10-0.17	0.10-0.17	0.10-0.18	0.10-0.18
0.05-0.08	0.05-0.08	0.05-0.08	0.05-0.09	0.05-0.09	0.06-0.10	0.06-0.10	0.06-0.12	0.06-0.12
0.05-0.08	0.05-0.08	0.05-0.08	0.05-0.09	0.05-0.09	0.06-0.10	0.06-0.10	0.06-0.12	0.06-0.12
0.05-0.08	0.05-0.08	0.05-0.08	0.05-0.09	0.05-0.09	0.06-0.10	0.06-0.10	0.06-0.12	0.06-0.12
0.05-0.08	0.05-0.08	0.05-0.08	0.05-0.09	0.05-0.09	0.06-0.10	0.06-0.10	0.06-0.12	0.06-0.12
0.06-0.09	0.06-0.09	0.06-0.09	0.06-0.10	0.06-0.10	0.06-0.10	0.06-0.10	0.06-0.10	0.06-0.10
0.06-0.09	0.06-0.09	0.06-0.09	0.06-0.10	0.06-0.10	0.06-0.10	0.06-0.10	0.06-0.10	0.06-0.10
0.05-0.09	0.05-0.09	0.05-0.09	0.05-0.10	0.05-0.10	0.05-0.10	0.05-0.10	0.05-0.10	0.05-0.10
0.05-0.09	0.05-0.09	0.05-0.09	0.05-0.10	0.05-0.10	0.05-0.10	0.05-0.10	0.05-0.10	0.05-0.10
0.05-0.09	0.05-0.09	0.05-0.09	0.05-0.10	0.05-0.10	0.05-0.10	0.05-0.10	0.05-0.10	0.05-0.10
0.05-0.09	0.05-0.09	0.05-0.09	0.05-0.10	0.05-0.10	0.05-0.10	0.05-0.10	0.05-0.10	0.05-0.10

Recommended Cutting Conditions



Machining data for TOP-DRILL 5xD

ISO	Material	Condition	Tensile strength (N/mm ²)	Hardness HB	Material No.	Cutting speed Vc (m/min)	
P	Non-alloy steel, cast steel, free cutting steel	<0.25%C	Annealed	420	125	1	220-350
		>=0.25%C	Annealed	650	190	2	180-280
		<0.55%C	Quenched and tempered	850	250	3	140-240
		>=0.55%C	Annealed	750	220	4	140-240
			Quenched and tempered	1000	300	5	140-240
	Low alloy steel and cast steel (Less than 5% of alloying elements)	Quenched and tempered	Annealed	600	200	6	140-240
			930	275	7	100-180	
			1000	300	8	100-180	
			1200	350	9	100-180	
	High alloy steel, cast steel and tool steel	Annealed	680	200	10	140-200	
		Quenched and tempered	1100	325	11	100-160	
M	Stainless steel and cast steel	Ferritic / martensitic	680	200	12	150-250	
		Martensitic	820	240	13	150-250	
		Austenitic	600	180	14	150-250	
K	Gray cast iron (GG)	Ferritic		160	15	160-260	
		Pearlitic		250	16	160-260	
	Cast iron nodular (GGG)	Ferritic		180	17	160-260	
		Pearlitic		260	18	160-260	
	Malleable cast iron	Ferritic		130	19	120-220	
Pearlitic			230	20	120-220		
N	Aluminum - Wrought alloy	Not cureable		60	21	200-350	
		Cured		100	22	200-350	
	Aluminum-cast, alloyed	<=12% Si	Not cureable		75	23	200-350
			Cured		90	24	200-350
		>12% Si	High temp.		130	25	200-350
	Copper alloys	>1% Pb	Free cutting		110	26	150-250
		Brass			90	27	150-250
			Electrolytic copper		100	28	150-250
	Non-metallic		Duroplastics, fiber plastics		70 Shore D	29	150-250
			Hard rubber		55 Shore D	30	150-250
S	High temp. alloys	Fe based	Annealed		200	31	30-60
			Cured		280	32	30-60
		Ni or Co based	Annealed		250	33	30-60
			Cured		350	34	30-60
			Cast		320	35	30-60
	Titanium, Ti alloys	Pure	Rm 400	190	36	50-80	
Alpha+beta alloys cured		Rm 1050	310	37	50-80		
H	Hardened steel	Hardened		55HRC	38	30-60	
		Hardened		60HRC	39	30-60	
	Chilled cast iron	Cast		400	40	30-60	
	Cast iron nodular	Hardened		55HRC	41	30-60	

► For more information of material groups, see the materials & grades "material conversion table"

■ Steel
 ■ Stainless steel
 ■ Cast iron
 ■ Nonferrous
 ■ High temp. alloys
 ■ Hardened steel

Recommended Cutting Conditions



Machining data for TOP-DRILL 5xD

Feed (mm/rev) vs. drill diameter Drill length 5xD								
SOMT 04 Ø12 - Ø13.5	SOMT 05 Ø14 - Ø16	SOMT 06 Ø17 - Ø19	SOMT 07 Ø20 - Ø22	SOMT 08 Ø23 - Ø26	SOMT 09 Ø27 - Ø31	SOMT 11 Ø32 - Ø36	SOMT 13 Ø37 - Ø43	SOMT 15 Ø44 - Ø50
0.04-0.05	0.04-0.05	0.04-0.05	0.04-0.05	0.04-0.06	0.06-0.08	0.06-0.08	0.08-0.10	0.08-0.10
0.06-0.08	0.06-0.08	0.06-0.08	0.06-0.10	0.06-0.10	0.08-0.12	0.08-0.12	0.08-0.14	0.10-0.14
0.06-0.10	0.06-0.10	0.06-0.10	0.06-0.12	0.06-0.12	0.10-0.15	0.10-0.15	0.10-0.17	0.10-0.17
0.06-0.10	0.06-0.10	0.06-0.10	0.06-0.12	0.06-0.12	0.10-0.15	0.10-0.15	0.10-0.17	0.10-0.17
0.06-0.10	0.06-0.10	0.06-0.10	0.06-0.12	0.06-0.12	0.10-0.15	0.10-0.15	0.10-0.17	0.10-0.17
0.06-0.12	0.06-0.12	0.06-0.12	0.08-0.16	0.08-0.16	0.08-0.18	0.10-0.20	0.10-0.20	0.10-0.22
0.06-0.12	0.06-0.12	0.06-0.12	0.08-0.16	0.08-0.16	0.08-0.18	0.10-0.20	0.10-0.20	0.10-0.22
0.06-0.12	0.06-0.12	0.06-0.12	0.08-0.16	0.08-0.16	0.08-0.18	0.10-0.20	0.10-0.20	0.10-0.22
0.06-0.12	0.06-0.12	0.06-0.12	0.08-0.16	0.08-0.16	0.08-0.18	0.10-0.20	0.10-0.20	0.10-0.22
0.06-0.10	0.06-0.10	0.06-0.10	0.08-0.12	0.08-0.12	0.08-0.16	0.08-0.18	0.10-0.18	0.10-0.20
0.06-0.10	0.06-0.10	0.06-0.10	0.08-0.12	0.08-0.12	0.08-0.16	0.08-0.18	0.10-0.18	0.10-0.20
0.06-0.10	0.06-0.10	0.06-0.10	0.06-0.12	0.06-0.12	0.08-0.16	0.08-0.18	0.10-0.18	0.10-0.20
0.06-0.10	0.06-0.10	0.06-0.10	0.06-0.12	0.06-0.12	0.08-0.16	0.08-0.18	0.10-0.18	0.10-0.20
0.08-0.14	0.08-0.14	0.08-0.14	0.08-0.16	0.08-0.16	0.10-0.18	0.10-0.18	0.10-0.20	0.10-0.20
0.08-0.14	0.08-0.14	0.08-0.14	0.08-0.16	0.08-0.16	0.10-0.18	0.10-0.18	0.10-0.20	0.10-0.20
0.08-0.14	0.08-0.14	0.08-0.14	0.08-0.16	0.08-0.16	0.10-0.18	0.10-0.18	0.10-0.20	0.10-0.20
0.08-0.14	0.08-0.14	0.08-0.14	0.08-0.16	0.08-0.16	0.10-0.18	0.10-0.18	0.10-0.20	0.10-0.20
0.08-0.12	0.08-0.12	0.08-0.14	0.08-0.16	0.08-0.16	0.10-0.16	0.10-0.16	0.10-0.16	0.10-0.16
0.08-0.12	0.08-0.12	0.08-0.14	0.08-0.16	0.08-0.16	0.10-0.16	0.10-0.16	0.10-0.16	0.10-0.16
0.06-0.15	0.06-0.15	0.06-0.15	0.08-0.16	0.08-0.16	0.08-0.16	0.08-0.16	0.10-0.17	0.10-0.17
0.06-0.15	0.06-0.15	0.06-0.15	0.08-0.16	0.08-0.16	0.08-0.16	0.08-0.16	0.10-0.17	0.10-0.17
0.06-0.15	0.06-0.15	0.06-0.15	0.08-0.16	0.08-0.16	0.08-0.16	0.08-0.16	0.10-0.17	0.10-0.17
0.06-0.15	0.06-0.15	0.06-0.15	0.08-0.16	0.08-0.16	0.08-0.16	0.08-0.16	0.10-0.17	0.10-0.17
0.06-0.15	0.06-0.15	0.06-0.15	0.08-0.16	0.08-0.16	0.08-0.16	0.08-0.16	0.10-0.17	0.10-0.17
0.06-0.15	0.06-0.15	0.06-0.15	0.08-0.16	0.08-0.16	0.08-0.15	0.08-0.16	0.10-0.17	0.10-0.17
0.06-0.15	0.06-0.15	0.06-0.15	0.08-0.16	0.08-0.16	0.08-0.15	0.08-0.16	0.10-0.17	0.10-0.17
0.06-0.15	0.06-0.15	0.06-0.15	0.08-0.16	0.08-0.16	0.08-0.15	0.08-0.16	0.10-0.17	0.10-0.17
0.06-0.15	0.06-0.15	0.06-0.15	0.08-0.16	0.08-0.16	0.10-0.16	0.10-0.16	0.10-0.17	0.10-0.17
0.06-0.15	0.06-0.15	0.06-0.15	0.08-0.16	0.08-0.16	0.10-0.16	0.10-0.16	0.10-0.17	0.10-0.17
0.05-0.07	0.05-0.07	0.05-0.08	0.05-0.08	0.05-0.08	0.06-0.09	0.06-0.09	0.06-0.10	0.06-0.10
0.05-0.07	0.05-0.07	0.05-0.08	0.05-0.08	0.05-0.08	0.06-0.09	0.06-0.09	0.06-0.10	0.06-0.10
0.05-0.07	0.05-0.07	0.05-0.08	0.05-0.08	0.05-0.08	0.06-0.09	0.06-0.09	0.06-0.10	0.06-0.10
0.05-0.07	0.05-0.07	0.05-0.08	0.05-0.08	0.05-0.08	0.06-0.09	0.06-0.09	0.06-0.10	0.06-0.10
0.05-0.08	0.05-0.08	0.05-0.08	0.06-0.09	0.06-0.09	0.06-0.10	0.06-0.10	0.06-0.10	0.06-0.10
0.05-0.08	0.05-0.08	0.05-0.08	0.06-0.09	0.06-0.09	0.06-0.10	0.06-0.10	0.06-0.10	0.06-0.10
0.05-0.08	0.05-0.08	0.05-0.08	0.05-0.09	0.05-0.09	0.05-0.10	0.05-0.10	0.05-0.10	0.05-0.10
0.05-0.08	0.05-0.08	0.05-0.08	0.05-0.09	0.05-0.09	0.05-0.10	0.05-0.10	0.05-0.10	0.05-0.10
0.05-0.08	0.05-0.08	0.05-0.08	0.05-0.09	0.05-0.09	0.05-0.10	0.05-0.10	0.05-0.10	0.05-0.10

Recommended Cutting Conditions



Machining data for TOP-DRILL cartridge

ISO	Material	Condition	Tensile strength (N/mm ²)	Hardness HB	Material No.	Cutting speed Vc (m/min)	
P	Non-alloy steel, cast steel, free cutting steel	<0.25%C	Annealed	420	125	1	250-350
		>=0.25%C	Annealed	650	190	2	160-250
		<0.55%C	Quenched and tempered	850	250	3	140-240
		>=0.55%C	Annealed	750	220	4	140-240
			Quenched and tempered	1000	300	5	140-240
	Low alloy steel and cast steel (Less than 5% of alloying elements)	Quenched and tempered	Annealed	600	200	6	140-240
			930	275	7	100-180	
			1000	300	8	100-180	
			1200	350	9	100-180	
	High alloy steel, cast steel and tool steel	Annealed	680	200	10	140-200	
		Quenched and tempered	1100	325	11	100-160	
M	Stainless steel and cast steel	Ferritic / martensitic	680	200	12	150-250	
		Martensitic	820	240	13	150-250	
		Austenitic	600	180	14	150-250	
K	Gray cast iron (GG)	Ferritic		160	15	160-260	
		Pearlitic		250	16	160-260	
	Cast iron nodular (GGG)	Ferritic		180	17	160-260	
		Pearlitic		260	18	160-260	
	Malleable cast iron	Ferritic		130	19	120-220	
Pearlitic			230	20	120-220		
N	Aluminum - Wrought alloy	Not cureable		60	21	200-350	
		Cured		100	22	200-350	
	Aluminum-cast, alloyed	<=12% Si	Not cureable		75	23	200-350
			Cured		90	24	200-350
		>12% Si	High temp.		130	25	200-350
	Copper alloys	>1% Pb	Free cutting		110	26	150-250
		Brass			90	27	150-250
			Electrolytic copper		100	28	150-250
	Non-metallic		Duroplastics, fiber plastics		70 Shore D	29	150-250
			Hard rubber		55 Shore D	30	150-250
S	High temp. alloys	Fe based	Annealed		200	31	30-60
			Cured		280	32	30-60
		Ni or Co based	Annealed		250	33	30-60
			Cured		350	34	30-60
			Cast		320	35	30-60
	Titanium, Ti alloys	Pure	Rm 400	190	36	50-80	
Alpha+beta alloys cured		Rm 1050	310	37	50-80		
H	Hardened steel	Hardened		55HRC	38	30-60	
		Hardened		60HRC	39	30-60	
	Chilled cast iron	Cast		400	40	30-60	
	Cast iron nodular	Hardened		55HRC	41	30-60	

► For more information of material groups, see the materials & grades "material conversion table"

■ Steel
 ■ Stainless steel
 ■ Cast iron
 ■ Nonferrous
 ■ High temp. alloys
 ■ Hardened steel

Recommended Cutting Conditions



Machining data for TOP-DRILL cartridge

Feed (mm/rev) vs. drill diameter Drill length 2,3,4xD					
SOMT 09 Ø51 - Ø55	SOMT 11 Ø56 - Ø60	SOMT 11 Ø61 - Ø65	SOMT 11 Ø66 - Ø70	SOMT 13 Ø71 - Ø75	SOMT 13 Ø76 - Ø80
0.06-0.12	0.06-0.12	0.06-0.12	0.06-0.12	0.06-0.12	0.06-0.12
0.06-0.16	0.06-0.16	0.06-0.16	0.06-0.16	0.06-0.16	0.06-0.16
0.08-0.18	0.08-0.18	0.08-0.18	0.08-0.18	0.08-0.18	0.08-0.18
0.08-0.18	0.08-0.18	0.08-0.18	0.08-0.18	0.08-0.18	0.08-0.18
0.08-0.18	0.08-0.18	0.08-0.18	0.08-0.18	0.08-0.18	0.08-0.18
0.08-0.20	0.08-0.20	0.08-0.20	0.08-0.20	0.08-0.20	0.08-0.20
0.08-0.20	0.08-0.20	0.08-0.20	0.08-0.20	0.08-0.20	0.08-0.20
0.08-0.20	0.08-0.20	0.08-0.20	0.08-0.20	0.08-0.20	0.08-0.20
0.08-0.20	0.08-0.20	0.08-0.20	0.08-0.20	0.08-0.20	0.08-0.20
0.08-0.20	0.08-0.20	0.08-0.20	0.08-0.20	0.08-0.20	0.08-0.20
0.08-0.18	0.08-0.18	0.08-0.18	0.08-0.18	0.08-0.18	0.08-0.18
0.08-0.18	0.08-0.18	0.08-0.18	0.08-0.18	0.08-0.18	0.08-0.18
0.08-0.18	0.08-0.18	0.08-0.18	0.08-0.18	0.08-0.18	0.08-0.18
0.08-0.18	0.08-0.18	0.08-0.18	0.08-0.18	0.08-0.18	0.08-0.18
0.10-0.22	0.10-0.22	0.10-0.22	0.10-0.22	0.10-0.22	0.10-0.22
0.10-0.22	0.10-0.22	0.10-0.22	0.10-0.22	0.10-0.22	0.10-0.22
0.10-0.22	0.10-0.22	0.10-0.22	0.10-0.22	0.10-0.22	0.10-0.22
0.10-0.22	0.10-0.22	0.10-0.22	0.10-0.22	0.10-0.22	0.10-0.22
0.10-0.18	0.10-0.18	0.10-0.18	0.10-0.18	0.10-0.18	0.10-0.18
0.10-0.18	0.10-0.18	0.10-0.18	0.10-0.18	0.10-0.18	0.10-0.18
0.06-0.18	0.06-0.18	0.06-0.18	0.06-0.18	0.06-0.18	0.06-0.18
0.06-0.18	0.06-0.18	0.06-0.18	0.06-0.18	0.06-0.18	0.06-0.18
0.06-0.18	0.06-0.18	0.06-0.18	0.06-0.18	0.06-0.18	0.06-0.18
0.06-0.18	0.06-0.18	0.06-0.18	0.06-0.18	0.06-0.18	0.06-0.18
0.06-0.18	0.06-0.18	0.06-0.18	0.06-0.18	0.06-0.18	0.06-0.18
0.10-0.18	0.10-0.18	0.10-0.18	0.10-0.18	0.10-0.18	0.10-0.18
0.10-0.18	0.10-0.18	0.10-0.18	0.10-0.18	0.10-0.18	0.10-0.18
0.10-0.18	0.10-0.18	0.10-0.18	0.10-0.18	0.10-0.18	0.10-0.18
0.10-0.18	0.10-0.18	0.10-0.18	0.10-0.18	0.10-0.18	0.10-0.18
0.10-0.18	0.10-0.18	0.10-0.18	0.10-0.18	0.10-0.18	0.10-0.18
0.06-0.10	0.06-0.10	0.06-0.10	0.06-0.10	0.06-0.10	0.06-0.10
0.06-0.10	0.06-0.10	0.06-0.10	0.06-0.10	0.06-0.10	0.06-0.10
0.06-0.10	0.06-0.10	0.06-0.10	0.06-0.10	0.06-0.10	0.06-0.10
0.06-0.10	0.06-0.10	0.06-0.10	0.06-0.10	0.06-0.10	0.06-0.10
0.06-0.10	0.06-0.10	0.06-0.10	0.06-0.10	0.06-0.10	0.06-0.10
0.06-0.10	0.06-0.10	0.06-0.10	0.06-0.10	0.06-0.10	0.06-0.10
0.05-0.10	0.05-0.10	0.05-0.10	0.05-0.10	0.05-0.10	0.05-0.10
0.05-0.10	0.05-0.10	0.05-0.10	0.05-0.10	0.05-0.10	0.05-0.10
0.05-0.10	0.05-0.10	0.05-0.10	0.05-0.10	0.05-0.10	0.05-0.10
0.05-0.10	0.05-0.10	0.05-0.10	0.05-0.10	0.05-0.10	0.05-0.10

Recommended Cutting Conditions



Machining data for T-DRILL 2,3,4xD

ISO	Material	Condition	Tensile strength (N/mm ²)	Hardness HB	Material No.	Cutting speed Vc (m/min)	
P	Non-alloy steel, cast steel, free cutting steel	<0.25%C	Annealed	420	125	1	250-350
		>=0.25%C	Annealed	650	190	2	180-250
		<0.55%C	Quenched and tempered	850	250	3	160-220
		>=0.55%C	Annealed	750	220	4	160-220
			Quenched and tempered	1000	300	5	160-220
	Low alloy steel and cast steel (Less than 5% of alloying elements)	Quenched and tempered	Annealed	600	200	6	150-220
			930	275	7	120-160	
			1000	300	8	120-160	
			1200	350	9	120-160	
	High alloy steel, cast steel and tool steel	Annealed	680	200	10	140-180	
		Quenched and tempered	1100	325	11	130-180	
M	Stainless steel and cast steel	Ferritic / martensitic	680	200	12	170-240	
		Martensitic	820	240	13	170-240	
		Austenitic	600	180	14	170-240	
K	Gray cast iron (GG)	Ferritic		160	15	180-250	
		Pearlitic		250	16	180-250	
	Cast iron nodular (GGG)	Ferritic		180	17	180-250	
		Pearlitic		260	18	180-250	
	Malleable cast iron	Ferritic		130	19	130-200	
Pearlitic			230	20	130-200		
N	Aluminum - Wrought alloy	Not cureable		60	21	330-380	
		Cured		100	22	330-380	
	Aluminum-cast, alloyed	<=12% Si	Not cureable		75	23	330-380
			Cured		90	24	330-380
		>12% Si	High temp.		130	25	330-380
	Copper alloys	>1% Pb	Free cutting		110	26	150-230
		Brass			90	27	150-230
			Electrolytic copper		100	28	150-230
	Non-metallic		Duroplastics, fiber plastics		70 Shore D	29	150-230
			Hard rubber		55 Shore D	30	150-230
S	High temp. alloys	Fe based	Annealed		200	31	30-60
			Cured		280	32	30-60
		Ni or Co based	Annealed		250	33	30-60
			Cured		350	34	30-60
			Cast		320	35	30-60
	Titanium, Ti alloys	Pure	Rm 400	190	36	30-60	
Alpha+beta alloys cured		Rm 1050	310	37	30-60		
H	Hardened steel	Hardened		55HRC	38	30-60	
		Hardened		60HRC	39	30-60	
	Chilled cast iron	Cast		400	40	30-60	
	Cast iron nodular	Hardened		55HRC	41	30-60	

► For more information of material groups, see the materials & grades "material conversion table"

■ Steel
 ■ Stainless steel
 ■ Cast iron
 ■ Nonferrous
 ■ High temp. alloys
 ■ Hardened steel

Recommended Cutting Conditions



Machining data for T-DRILL 2,3,4xD

Feed (mm/rev) vs. drill diameter Drill length 2,3,4xD					
SPMG 05 Ø12.5 - Ø15	SPMG 06 Ø16 - Ø21	SPMG 07 Ø22 - Ø27	SPMG 09 Ø28 - Ø33	SPMG 11 Ø34 - Ø41	SPMG 14 Ø42 - Ø50
0.04-0.06	0.04-0.06	0.04-0.08	0.04-0.08	0.06-0.10	0.06-0.12
0.05-0.08	0.06-0.10	0.06-0.12	0.07-0.13	0.08-0.15	0.08-0.16
0.06-0.12	0.08-0.15	0.10-0.18	0.12-0.22	0.12-0.24	0.13-0.25
0.06-0.12	0.08-0.15	0.10-0.18	0.12-0.22	0.12-0.24	0.13-0.25
0.06-0.12	0.08-0.14	0.10-0.18	0.12-0.20	0.12-0.20	0.13-0.20
0.06-0.15	0.06-0.15	0.08-0.18	0.08-0.18	0.08-0.18	0.08-0.18
0.06-0.15	0.06-0.15	0.08-0.18	0.08-0.18	0.08-0.18	0.08-0.18
0.06-0.15	0.06-0.15	0.08-0.18	0.08-0.18	0.08-0.18	0.08-0.18
0.06-0.10	0.06-0.10	0.08-0.12	0.08-0.14	0.08-0.14	0.08-0.14
0.06-0.10	0.08-0.12	0.10-0.15	0.12-0.15	0.12-0.18	0.13-0.18
0.05-0.10	0.06-0.12	0.08-0.15	0.09-0.16	0.10-0.17	0.11-0.18
0.05-0.10	0.06-0.12	0.08-0.15	0.09-0.16	0.10-0.17	0.11-0.18
0.05-0.10	0.06-0.12	0.08-0.15	0.09-0.16	0.10-0.17	0.11-0.18
0.06-0.12	0.08-0.16	0.12-0.20	0.15-0.25	0.16-0.28	0.18-0.30
0.06-0.12	0.08-0.16	0.12-0.20	0.15-0.25	0.16-0.28	0.18-0.30
0.06-0.12	0.08-0.16	0.12-0.20	0.15-0.25	0.16-0.28	0.18-0.30
0.06-0.12	0.08-0.16	0.12-0.20	0.15-0.25	0.16-0.28	0.18-0.30
0.06-0.10	0.08-0.15	0.10-0.18	0.12-0.20	0.15-0.23	0.16-0.25
0.06-0.10	0.08-0.15	0.10-0.18	0.12-0.20	0.15-0.23	0.16-0.25
0.06-0.14	0.08-0.15	0.10-0.20	0.12-0.22	0.14-0.23	0.15-0.26
0.06-0.14	0.08-0.15	0.10-0.20	0.12-0.22	0.14-0.23	0.15-0.26
0.06-0.14	0.08-0.15	0.10-0.20	0.12-0.22	0.14-0.23	0.15-0.26
0.06-0.14	0.08-0.15	0.10-0.20	0.12-0.22	0.14-0.23	0.15-0.26
0.06-0.13	0.06-0.13	0.08-0.15	0.08-0.15	0.08-0.15	0.08-0.15
0.06-0.13	0.06-0.13	0.08-0.15	0.08-0.15	0.08-0.15	0.08-0.15
0.06-0.13	0.06-0.13	0.08-0.15	0.08-0.15	0.08-0.15	0.08-0.15
0.06-0.13	0.06-0.13	0.08-0.15	0.08-0.15	0.08-0.15	0.08-0.15
0.05-0.08	0.05-0.08	0.05-0.09	0.05-0.09	0.05-0.09	0.05-0.09
0.05-0.08	0.05-0.08	0.05-0.09	0.05-0.09	0.05-0.09	0.05-0.09
0.05-0.08	0.05-0.08	0.05-0.09	0.05-0.09	0.05-0.09	0.05-0.09
0.05-0.08	0.05-0.08	0.05-0.09	0.05-0.09	0.05-0.09	0.05-0.09
0.05-0.10	0.06-0.14	0.08-0.18	0.10-0.22	0.14-0.23	0.15-0.24
0.05-0.10	0.06-0.14	0.08-0.18	0.10-0.22	0.14-0.23	0.15-0.24
0.05-0.09	0.05-0.09	0.05-0.10	0.05-0.10	0.05-0.10	0.05-0.10
0.05-0.09	0.05-0.09	0.05-0.10	0.05-0.10	0.05-0.10	0.05-0.10
0.05-0.09	0.05-0.09	0.05-0.10	0.05-0.10	0.05-0.10	0.05-0.10

Recommended Cutting Conditions



Machining data for T-DRILL 5xD

ISO	Material	Condition	Tensile strength (N/mm ²)	Hardness HB	Material No.	Cutting speed Vc (m/min)	
P	Non-alloy steel, cast steel, free cutting steel	<0.25%C	Annealed	420	125	1	250-350
		>=0.25%C	Annealed	650	190	2	180-250
		<0.55%C	Quenched and tempered	850	250	3	160-220
		>=0.55%C	Annealed	750	220	4	160-220
			Quenched and tempered	1000	300	5	160-220
	Low alloy steel and cast steel (Less than 5% of alloying elements)	Quenched and tempered	Annealed	600	200	6	150-220
			930	275	7	120-160	
			1000	300	8	120-160	
			1200	350	9	120-160	
	High alloy steel, cast steel and tool steel	Annealed	680	200	10	140-180	
		Quenched and tempered	1100	325	11	130-180	
M	Stainless steel and cast steel	Ferritic / martensitic	680	200	12	170-240	
		Martensitic	820	240	13	170-240	
		Austenitic	600	180	14	170-240	
K	Gray cast iron (GG)	Ferritic		160	15	180-250	
		Pearlitic		250	16	180-250	
	Cast iron nodular (GGG)	Ferritic		180	17	180-250	
		Pearlitic		260	18	180-250	
	Malleable cast iron	Ferritic		130	19	130-200	
Pearlitic			230	20	130-200		
N	Aluminum - Wrought alloy	Not cureable		60	21	330-380	
		Cured		100	22	330-380	
	Aluminum-cast, alloyed	<=12% Si	Not cureable		75	23	330-380
			Cured		90	24	330-380
		>12% Si	High temp.		130	25	330-380
	Copper alloys	>1% Pb	Free cutting		110	26	150-230
		Brass			90	27	150-230
			Electrolytic copper		100	28	150-230
	Non-metallic		Duroplastics, fiber plastics		70 Shore D	29	150-230
			Hard rubber		55 Shore D	30	150-230
S	High temp. alloys	Fe based	Annealed		200	31	30-60
			Cured		280	32	30-60
		Ni or Co based	Annealed		250	33	30-60
			Cured		350	34	30-60
			Cast		320	35	30-60
	Titanium, Ti alloys	Pure	Rm 400	190	36	30-60	
Alpha+beta alloys cured		Rm 1050	310	37	30-60		
H	Hardened steel	Hardened		55HRC	38	30-60	
		Hardened		60HRC	39	30-60	
	Chilled cast iron	Cast		400	40	30-60	
	Cast iron nodular	Hardened		55HRC	41	30-60	

► For more information of material groups, see the materials & grades "material conversion table"

■ Steel
 ■ Stainless steel
 ■ Cast iron
 ■ Nonferrous
 ■ High temp. alloys
 ■ Hardened steel

Recommended Cutting Conditions



Machining data for T-DRILL 5xD

Feed (mm/rev) vs. drill diameter Drill length 5xD					
SPMG 05 Ø12.5 - Ø15	SPMG 06 Ø16 - Ø21	SPMG 07 Ø22 - Ø27	SPMG 09 Ø28 - Ø33	SPMG 11 Ø34 - Ø41	SPMG 14 Ø42 - Ø50
0.04-0.05	0.04-0.05	0.04-0.06	0.04-0.07	0.06-0.08	0.06-0.10
0.06-0.08	0.06-0.08	0.06-0.10	0.07-0.12	0.08-0.13	0.08-0.14
0.06-0.10	0.08-0.13	0.10-0.16	0.12-0.20	0.12-0.22	0.13-0.23
0.06-0.10	0.08-0.13	0.10-0.16	0.12-0.20	0.12-0.22	0.13-0.23
0.06-0.10	0.08-0.12	0.10-0.16	0.12-0.18	0.12-0.18	0.13-0.18
0.06-0.12	0.06-0.13	0.08-0.16	0.08-0.16	0.08-0.17	0.08-0.17
0.06-0.12	0.06-0.13	0.08-0.16	0.08-0.16	0.08-0.17	0.08-0.17
0.06-0.12	0.06-0.13	0.08-0.16	0.08-0.16	0.08-0.17	0.08-0.17
0.06-0.08	0.06-0.08	0.08-0.10	0.08-0.12	0.08-0.12	0.08-0.12
0.06-0.09	0.08-0.10	0.10-0.13	0.12-0.13	0.12-0.15	0.12-0.16
0.05-0.09	0.06-0.10	0.08-0.13	0.09-0.15	0.10-0.15	0.10-0.17
0.05-0.09	0.06-0.10	0.08-0.13	0.09-0.15	0.10-0.15	0.10-0.17
0.05-0.09	0.06-0.10	0.08-0.13	0.09-0.15	0.10-0.15	0.10-0.17
0.06-0.10	0.08-0.15	0.12-0.18	0.15-0.22	0.16-0.25	0.18-0.28
0.06-0.10	0.08-0.15	0.12-0.18	0.15-0.22	0.16-0.25	0.18-0.28
0.06-0.10	0.08-0.15	0.12-0.18	0.15-0.22	0.16-0.25	0.18-0.28
0.06-0.10	0.08-0.15	0.12-0.18	0.15-0.22	0.16-0.25	0.18-0.28
0.06-0.08	0.08-0.12	0.10-0.16	0.12-0.18	0.15-0.22	0.16-0.23
0.06-0.08	0.08-0.12	0.10-0.16	0.12-0.18	0.15-0.22	0.16-0.23
0.06-0.12	0.08-0.15	0.10-0.13	0.12-0.18	0.14-0.20	0.14-0.24
0.06-0.12	0.08-0.15	0.10-0.13	0.12-0.18	0.14-0.20	0.14-0.24
0.06-0.12	0.08-0.15	0.10-0.13	0.12-0.18	0.14-0.20	0.14-0.24
0.06-0.12	0.08-0.15	0.10-0.13	0.12-0.18	0.14-0.20	0.14-0.24
0.06-0.12	0.08-0.15	0.10-0.13	0.12-0.18	0.14-0.20	0.14-0.24
0.06-0.12	0.06-0.12	0.08-0.13	0.08-0.13	0.08-0.14	0.08-0.14
0.06-0.12	0.06-0.12	0.08-0.13	0.08-0.13	0.08-0.14	0.08-0.14
0.06-0.12	0.06-0.12	0.08-0.13	0.08-0.13	0.08-0.14	0.08-0.14
0.06-0.12	0.06-0.12	0.08-0.13	0.08-0.13	0.08-0.14	0.08-0.14
0.05-0.07	0.05-0.07	0.05-0.08	0.05-0.08	0.05-0.08	0.05-0.08
0.05-0.07	0.05-0.07	0.05-0.08	0.05-0.08	0.05-0.08	0.05-0.08
0.05-0.07	0.05-0.07	0.05-0.08	0.05-0.08	0.05-0.08	0.05-0.08
0.05-0.07	0.05-0.07	0.05-0.08	0.05-0.08	0.05-0.08	0.05-0.08
0.05-0.07	0.05-0.07	0.05-0.08	0.05-0.08	0.05-0.08	0.05-0.08
0.05-0.09	0.08-0.13	0.08-0.17	0.10-0.20	0.14-0.22	0.14-0.24
0.05-0.09	0.08-0.13	0.08-0.17	0.10-0.20	0.14-0.22	0.14-0.24
0.05-0.08	0.05-0.08	0.05-0.09	0.05-0.09	0.05-0.09	0.05-0.09
0.05-0.08	0.05-0.08	0.05-0.09	0.05-0.09	0.05-0.09	0.05-0.09
0.05-0.08	0.05-0.08	0.05-0.09	0.05-0.09	0.05-0.09	0.05-0.09
0.05-0.08	0.05-0.08	0.05-0.09	0.05-0.09	0.05-0.09	0.05-0.09

Recommended Cutting Conditions



Machining data for T-DRILL cartridge

ISO	Material	Condition	Tensile strength (N/mm ²)	Hardness HB	Material No.	Cutting speed Vc (m/min)	
P	Non-alloy steel, cast steel, free cutting steel	<0.25%C	Annealed	420	125	1	250-350
		>=0.25%C	Annealed	650	190	2	180-250
		<0.55%C	Quenched and tempered	850	250	3	160-220
		>=0.55%C	Annealed	750	220	4	160-220
			Quenched and tempered	1000	300	5	160-220
	Low alloy steel and cast steel (Less than 5% of alloying elements)	Quenched and tempered	Annealed	600	200	6	150-220
			930	275	7	120-160	
			1000	300	8	120-160	
			1200	350	9	120-160	
	High alloy steel, cast steel and tool steel	Annealed	680	200	10	140-180	
		Quenched and tempered	1100	325	11	130-180	
M	Stainless steel and cast steel	Ferritic / martensitic	680	200	12	170-240	
		Martensitic	820	240	13	170-240	
		Austenitic	600	180	14	170-240	
K	Gray cast iron (GG)	Ferritic		160	15	180-250	
		Pearlitic		250	16	180-250	
	Cast iron nodular (GGG)	Ferritic		180	17	180-250	
		Pearlitic		260	18	180-250	
	Malleable cast iron	Ferritic		130	19	130-200	
Pearlitic			230	20	130-200		
N	Aluminum - Wrought alloy	Not cureable		60	21	330-380	
		Cured		100	22	330-380	
	Aluminum-cast, alloyed	<=12% Si	Not cureable		75	23	330-380
			Cured		90	24	330-380
		>12% Si	High temp.		130	25	330-380
	Copper alloys	>1% Pb	Free cutting		110	26	150-230
		Brass			90	27	150-230
			Electrolitic copper		100	28	150-230
	Non-metallic		Duroplastics, fiber plastics		70 Shore D	29	150-230
Hard rubber				55 Shore D	30	150-230	
S	High temp. alloys	Fe based	Annealed		200	31	30-60
			Cured		280	32	30-60
		Ni or Co based	Annealed		250	33	30-60
			Cured		350	34	30-60
			Cast		320	35	30-60
	Titanium, Ti alloys	Pure	Rm 400	190	36	30-60	
Alpha+beta alloys cured		Rm 1050	310	37	30-60		
H	Hardened steel	Hardened		55HRC	38	30-60	
		Hardened		60HRC	39	30-60	
	Chilled cast iron	Cast		400	40	30-60	
	Cast iron nodular	Hardened		55HRC	41	30-60	

► For more information of material groups, see the materials & grades "material conversion table"

■ Steel
 ■ Stainless steel
 ■ Cast iron
 ■ Nonferrous
 ■ High temp. alloys
 ■ Hardened steel

Recommended Cutting Conditions



Machining data for T-DRILL cartridge

Feed (mm/rev) vs. drill diameter Drill length 5xD					
SPMG 07 Ø51 - Ø53	SPMG 07 Ø54 - Ø56	SPMG 09 Ø57 - Ø62	SPMG 09 Ø63- Ø66	SPMG 11 Ø67 - Ø73	SPMG 12 Ø74 - Ø80
0.06-0.12	0.06-0.12	0.06-0.12	0.06-0.12	0.06-0.12	0.06-0.12
0.06-0.16	0.06-0.12	0.06-0.16	0.06-0.16	0.06-0.16	0.06-0.16
0.08-0.16	0.08-0.16	0.08-0.16	0.08-0.16	0.08-0.18	0.08-0.18
0.08-0.16	0.08-0.16	0.08-0.16	0.08-0.16	0.08-0.18	0.08-0.18
0.08-0.16	0.08-0.16	0.08-0.16	0.08-0.16	0.08-0.18	0.08-0.18
0.08-0.18	0.08-0.18	0.08-0.18	0.08-0.18	0.08-0.18	0.08-0.18
0.08-0.18	0.08-0.18	0.08-0.18	0.08-0.18	0.08-0.18	0.08-0.18
0.08-0.18	0.08-0.18	0.08-0.18	0.08-0.18	0.08-0.18	0.08-0.18
0.08-0.18	0.08-0.18	0.08-0.18	0.08-0.18	0.08-0.18	0.08-0.18
0.08-0.16	0.08-0.16	0.08-0.16	0.08-0.16	0.08-0.16	0.08-0.16
0.06-0.12	0.06-0.12	0.08-0.15	0.08-0.15	0.08-0.15	0.08-0.15
0.06-0.12	0.06-0.12	0.08-0.15	0.08-0.15	0.08-0.15	0.08-0.15
0.06-0.12	0.06-0.12	0.08-0.15	0.08-0.15	0.08-0.15	0.08-0.15
0.12-0.20	0.12-0.20	0.12-0.20	0.12-0.20	0.15-0.22	0.15-0.22
0.12-0.20	0.12-0.20	0.12-0.20	0.12-0.20	0.15-0.22	0.15-0.22
0.12-0.20	0.12-0.20	0.12-0.20	0.12-0.20	0.15-0.22	0.15-0.22
0.12-0.20	0.12-0.20	0.12-0.20	0.12-0.20	0.15-0.22	0.15-0.22
0.10-0.18	0.10-0.18	0.10-0.18	0.10-0.18	0.12-0.20	0.12-0.20
0.10-0.18	0.10-0.18	0.10-0.18	0.10-0.18	0.12-0.20	0.12-0.20
0.06-0.18	0.06-0.18	0.06-0.18	0.06-0.18	0.06-0.18	0.06-0.18
0.06-0.18	0.06-0.18	0.06-0.18	0.06-0.18	0.06-0.18	0.06-0.18
0.06-0.18	0.06-0.18	0.06-0.18	0.06-0.18	0.06-0.18	0.06-0.18
0.06-0.18	0.06-0.18	0.06-0.18	0.06-0.18	0.06-0.18	0.06-0.18
0.06-0.18	0.06-0.18	0.06-0.18	0.06-0.18	0.06-0.18	0.06-0.18
0.10-0.18	0.10-0.18	0.10-0.18	0.10-0.18	0.10-0.18	0.10-0.18
0.10-0.18	0.10-0.18	0.10-0.18	0.10-0.18	0.10-0.18	0.10-0.18
0.10-0.18	0.10-0.18	0.10-0.18	0.10-0.18	0.10-0.18	0.10-0.18
0.10-0.18	0.10-0.18	0.10-0.18	0.10-0.18	0.10-0.18	0.10-0.18
0.10-0.18	0.10-0.18	0.10-0.18	0.10-0.18	0.10-0.18	0.10-0.18
0.06-0.10	0.06-0.10	0.06-0.10	0.06-0.10	0.06-0.10	0.06-0.10
0.06-0.10	0.06-0.10	0.06-0.10	0.06-0.10	0.06-0.10	0.06-0.10
0.06-0.10	0.06-0.10	0.06-0.10	0.06-0.10	0.06-0.10	0.06-0.10
0.06-0.10	0.06-0.10	0.06-0.10	0.06-0.10	0.06-0.10	0.06-0.10
0.06-0.10	0.06-0.10	0.06-0.10	0.06-0.10	0.06-0.10	0.06-0.10
0.06-0.10	0.06-0.10	0.06-0.10	0.06-0.10	0.06-0.10	0.06-0.10
0.06-0.10	0.06-0.10	0.06-0.10	0.06-0.10	0.06-0.10	0.06-0.10
0.05-0.10	0.05-0.10	0.05-0.10	0.05-0.10	0.05-0.10	0.05-0.10
0.05-0.10	0.05-0.10	0.05-0.10	0.05-0.10	0.05-0.10	0.05-0.10
0.05-0.10	0.05-0.10	0.05-0.10	0.05-0.10	0.05-0.10	0.05-0.10
0.05-0.10	0.05-0.10	0.05-0.10	0.05-0.10	0.05-0.10	0.05-0.10

Recommended Cutting Conditions



Machining data for TOP-CAP

ISO	Material	Condition	Tensile strength (N/mm ²)	Hardness HB	Material No.	
P	Non-alloy steel, cast steel, free cutting steel	<0.25%C	Annealed	420	125	1
		>=0.25%C	Annealed	650	190	2
		<0.55%C	Quenched and tempered	850	250	3
		>=0.55%C	Annealed	750	220	4
			Quenched and tempered	1000	300	5
	Low alloy steel and cast steel (Less than 5% of alloying elements)		Annealed	600	200	6
			Quenched and tempered	930	275	7
				1000	300	8
				1200	350	9
	High alloy steel, cast steel and tool steel		Annealed	680	200	10
			Quenched and tempered	1100	325	11
M	Stainless steel and cast steel	Ferritic / martensitic	680	200	12	
		Martensitic	820	240	13	
		Austenitic	600	180	14	
K	Gray cast iron (GG)	Ferritic		160	15	
		Pearlitic		250	16	
	Cast iron nodular (GGG)	Ferritic		180	17	
		Pearlitic		260	18	
	Malleable cast iron	Ferritic		130	19	
	Pearlitic		230	20		
N	Aluminum - Wrought alloy	Not cureable		60	21	
		Cured		100	22	
	Aluminum-cast, alloyed	<=12% Si	Not cureable		75	23
			Cured		90	24
		>12% Si	High temp.		130	25
	Copper alloys		>1% Pb	Free cutting	110	26
			Brass		90	27
			Electrolitic copper		100	28
	Non-metallic		Duroplastics, fiber plastics		70 Shore D	29
Hard rubber				55 Shore D	30	
S	High temp. alloys	Fe based	Annealed		200	31
			Cured		280	32
		Ni or Co based	Annealed		250	33
			Cured		350	34
			Cast		320	35
	Titanium, Ti alloys		Pure	Rm 400	190	36
Alpha+beta alloys cured			Rm 1050	310	37	
H	Hardened steel	Hardened		55HRC	38	
		Hardened		60HRC	39	
	Chilled cast iron	Cast		400	40	
	Cast iron nodular	Hardened		55HRC	41	

► For more information of material groups, see the materials & grades "material conversion table"

■ Steel
 ■ Stainless steel
 ■ Cast iron
 ■ Nonferrous
 ■ High temp. alloys
 ■ Hardened steel

Recommended Cutting Conditions



Machining data for TOP-CAP

Drilling		Turning & boring		Grooving	
Vc (m/min)	Feed (mm/rev)	Vc (m/min)	Feed (mm/rev)	Vc (m/min)	Feed (mm/rev)
120-260	0.05-0.06	140-280	0.04-0.14	120-250	0.04-0.25
80-190	0.05-0.15	90-200	0.04-0.12	80-180	0.04-0.25
100-280	0.06-0.18	100-200	0.04-0.15	80-180	0.04-0.25
100-280	0.06-0.18	100-200	0.04-0.15	80-180	0.04-0.25
100-280	0.06-0.18	100-200	0.04-0.15	80-180	0.04-0.25
100-280	0.06-0.18	100-200	0.04-0.15	80-180	0.04-0.25
60-180	0.04-0.15	80-180	0.07-0.12	60-160	0.04-0.25
60-180	0.04-0.15	80-180	0.07-0.12	60-160	0.04-0.25
60-180	0.04-0.15	80-180	0.07-0.12	60-160	0.04-0.25
80-190	0.05-0.15	80-200	0.04-0.12	80-160	0.04-0.25
50-150	0.04-0.14	60-150	0.04-0.12	50-120	0.04-0.25
50-210	0.04-0.15	60-230	0.07-0.12	50-200	0.04-0.25
50-210	0.04-0.15	60-230	0.07-0.12	50-200	0.04-0.25
50-210	0.04-0.15	60-230	0.07-0.12	50-200	0.04-0.25
100-300	0.06-0.23	120-230	0.07-0.2	100-200	0.04-0.25
100-300	0.06-0.23	120-230	0.07-0.2	100-200	0.04-0.25
100-300	0.06-0.23	120-230	0.07-0.2	100-200	0.04-0.25
100-300	0.06-0.23	120-230	0.07-0.2	100-200	0.04-0.25
100-200	0.06-0.15	120-230	0.04-0.13	100-200	0.04-0.25
100-200	0.06-0.15	120-230	0.04-0.13	100-200	0.04-0.25
120-500	0.05-0.3	120-700	0.04-0.25	100-700	0.04-0.25
120-500	0.05-0.3	120-700	0.04-0.25	100-700	0.04-0.25
120-500	0.05-0.3	120-700	0.04-0.25	100-700	0.04-0.25
120-500	0.05-0.3	120-700	0.04-0.25	100-700	0.04-0.25
120-500	0.05-0.3	120-700	0.04-0.25	100-700	0.04-0.25
80-380	0.05-0.23	80-500	0.04-0.2	80-350	0.04-0.25
80-380	0.05-0.23	80-500	0.04-0.2	80-350	0.04-0.25
80-380	0.05-0.23	80-500	0.04-0.2	80-350	0.04-0.25
50-140	0.04-0.14	50-160	0.04-0.12	50-140	0.04-0.25
50-140	0.04-0.14	50-160	0.04-0.12	50-140	0.04-0.25
20-50	0.04-0.05	20-80	0.04-0.05	20-50	0.04-0.05
20-50	0.04-0.05	20-80	0.04-0.05	20-50	0.04-0.05
20-50	0.04-0.05	20-80	0.04-0.05	20-50	0.04-0.05
20-50	0.04-0.05	20-80	0.04-0.05	20-50	0.04-0.05
20-50	0.04-0.05	20-80	0.04-0.05	20-50	0.04-0.05
20-50	0.04-0.05	20-80	0.04-0.05	20-50	0.04-0.05
30-60	0.04-0.05	30-100	0.04-0.05	30-80	0.04-0.05
30-60	0.04-0.05	30-100	0.04-0.05	30-80	0.04-0.05
20-40	0.04-0.05	20-70	0.04-0.05	20-50	0.04-0.05
20-40	0.04-0.05	20-70	0.04-0.05	20-50	0.04-0.05
20-40	0.04-0.05	20-70	0.04-0.05	20-50	0.04-0.05
20-40	0.04-0.05	20-70	0.04-0.05	20-50	0.04-0.05
20-40	0.04-0.05	20-70	0.04-0.05	20-50	0.04-0.05

Recommended Cutting Conditions

Machining data for DRILL-SFEED 3,5,8xD

ISO	Material	Condition	Tensile strength (N/mm ²)	Hardness HB	Material No.	
P	Non-alloy steel, cast steel, free cutting steel	<0.25%C	Annealed	420	125	1
		≥0.25%C	Annealed	650	190	2
		<0.55%C	Quenched and tempered	850	250	3
		≥0.55%C	Annealed	750	220	4
			Quenched and tempered	1000	300	5
	Low alloy steel and cast steel (Less than 5% of alloying elements)		Annealed	600	200	6
			Quenched and tempered	930	275	7
				1000	300	8
				1200	350	9
	High alloy steel, cast steel and tool steel		Annealed	680	200	10
			Quenched and tempered	1100	325	11
M	Stainless steel and cast steel	Ferritic / martensitic	680	200	12	
		Martensitic	820	240	13	
		Austenitic	600	180	14	
K	Gray cast iron (GG)	Ferritic		160	15	
		Pearlitic		250	16	
	Cast iron nodular (GGG)	Ferritic		180	17	
		Pearlitic		260	18	
	Malleable cast iron	Ferritic		130	19	
	Pearlitic		230	20		
N	Aluminum - Wrought alloy	Not cureable		60	21	
		Cured		100	22	
	Aluminum-cast, alloyed	≤12% Si	Not cureable		75	23
			Cured		90	24
		>12% Si	High temp.		130	25
	Copper alloys		>1% Pb	Free cutting	110	26
			Brass		90	27
			Electrolitic copper		100	28
Non-metallic		Duroplastics, fiber plastics		70 Shore D	29	
		Hard rubber		55 Shore D	30	
S	High temp. alloys	Fe based	Annealed	200	31	
			Cured	280	32	
		Ni or Co based	Annealed	250	33	
			Cured	350	34	
			Cast	320	35	
	Titanium, Ti alloys		Pure	Rm 400	190	36
Alpha+beta alloys cured			Rm 1050	310	37	
H	Hardened steel	Hardened		55HRC	38	
		Hardened		60HRC	39	
	Chilled cast iron	Cast		400	40	
Cast iron nodular	Hardened		55HRC	41		

► For more information of material groups, see the materials & grades "material conversion table"

■ Steel
 ■ Stainless steel
 ■ Cast iron
 ■ Nonferrous
 ■ High temp. alloys
 ■ Hardened steel

Recommended Cutting Conditions



Machining data for DRILL-RUSH

ISO	Material	Condition	Tensile strength (N/mm ²)	Hardness HB	Material No.	Cutting speed Vc (m/min)	
P	Non-alloy steel, cast steel, free cutting steel	<0.25%C	Annealed	420	125	1	80-140
		>=0.25%C	Annealed	650	190	2	80-130
		<0.55%C	Quenched and tempered	850	250	3	80-120
		>=0.55%C	Annealed	750	220	4	70-110
			Quenched and tempered	1000	300	5	50-90
	Low alloy steel and cast steel (Less than 5% of alloying elements)	Quenched and tempered	Annealed	600	200	6	70-120
			930	275	7	70-110	
			1000	300	8	50-90	
			1200	350	9	40-70	
	High alloy steel, cast steel and tool steel	Annealed	680	200	10	50-90	
		Quenched and tempered	1100	325	11	40-80	
M	Stainless steel and cast steel	Ferritic / martensitic	680	200	12	40-70	
		Martensitic	820	240	13	40-70	
		Austenitic	600	180	14	30-70	
K	Gray cast iron (GG)	Ferritic		160	15	90-160	
		Pearlitic		250	16	80-140	
	Cast iron nodular (GGG)	Ferritic		180	17	90-180	
		Pearlitic		260	18	80-140	
	Malleable cast iron	Ferritic		130	19	90-160	
Pearlitic			230	20	80-140		
N	Aluminum - Wrought alloy	Not cureable		60	21	90-220	
		Cured		100	22	90-220	
	Aluminum-cast, alloyed	<=12% Si	Not cureable		75	23	90-220
			Cured		90	24	90-220
		>12% Si	High temp.		130	25	80-160
	Copper alloys	>1% Pb	Free cutting		110	26	90-220
		Brass			90	27	90-220
			Electrolitic copper		100	28	90-220
	Non-metallic		Duroplastics, fiber plastics		70 Shore D	29	
Hard rubber				55 Shore D	30		
S	High temp. alloys	Fe based	Annealed		200	31	30-60
			Cured		280	32	20-50
		Ni or Co based	Annealed		250	33	20-50
			Cured		350	34	20-50
			Cast		320	35	20-50
	Titanium, Ti alloys	Pure	Rm 400	190	36	20-50	
Alpha+beta alloys cured		Rm 1050	310	37	20-50		
H	Hardened steel	Hardened		55HRC	38	20-50	
		Hardened		60HRC	39	20-50	
	Chilled cast iron	Cast		400	40		
	Cast iron nodular	Hardened		55HRC	41		

► For more information of material groups, see the materials & grades "material conversion table"

■ Steel
 ■ Stainless steel
 ■ Cast iron
 ■ Nonferrous
 ■ High temp. alloys
 ■ Hardened steel

Recommended Cutting Conditions



Machining data for MODU-R-DRILL

ISO	Material	Condition	Tensile strength (N/mm ²)	Hardness HB	Material No.	Cutting speed Vc (m/min)	
P	Non-alloy steel, cast steel, free cutting steel	<0.25%C	Annealed	420	125	1	120-200
		>=0.25%C	Annealed	650	190	2	120-200
		<0.55%C	Quenched and tempered	850	250	3	130-190
		>=0.55%C	Annealed	750	220	4	130-190
			Quenched and tempered	1000	300	5	130-190
	Low alloy steel and cast steel (Less than 5% of alloying elements)	Quenched and tempered	Annealed	600	200	6	100-200
			930	275	7	100-200	
			1000	300	8	100-200	
			1200	350	9	100-200	
	High alloy steel, cast steel and tool steel	Annealed	680	200	10	100-160	
		Quenched and tempered	1100	325	11	100-160	
M	Stainless steel and cast steel	Ferritic / martensitic	680	200	12	80-140	
		Martensitic	820	240	13	80-140	
		Austenitic	600	180	14	80-140	
K	Gray cast iron (GG)	Ferritic		160	15	100-250	
		Pearlitic		250	16	100-250	
	Cast iron nodular (GGG)	Ferritic		180	17	100-250	
		Pearlitic		260	18	100-250	
	Malleable cast iron	Ferritic		130	19	100-250	
Pearlitic			230	20	100-250		
N	Aluminum - Wrought alloy	Not cureable		60	21	160-260	
		Cured		100	22	160-260	
	Aluminum-cast, alloyed	<=12% Si	Not cureable		75	23	160-260
			Cured		90	24	160-260
		>12% Si	High temp.		130	25	160-260
	Copper alloys	>1% Pb	Free cutting		110	26	160-260
		Brass			90	27	160-260
			Electrolitic copper		100	28	160-260
	Non-metallic		Duroplastics, fiber plastics		70 Shore D	29	
			Hard rubber		55 Shore D	30	
S	High temp. alloys	Fe based	Annealed		200	31	30-60
			Cured		280	32	30-80
		Ni or Co based	Annealed		250	33	30-80
			Cured		350	34	30-80
			Cast		320	35	30-80
	Titanium, Ti alloys	Pure	Rm 400	190	36	30-80	
		Alpha+beta alloys cured	Rm 1050	310	37	30-80	
H	Hardened steel	Hardened		55HRC	38	20-50	
		Hardened		60HRC	39	20-50	
	Chilled cast iron	Cast		400	40		
	Cast iron nodular	Hardened		55HRC	41		

► For more information of material groups, see the materials & grades "material conversion table"

■ Steel
 ■ Stainless steel
 ■ Cast iron
 ■ Nonferrous
 ■ High temp. alloys
 ■ Hardened steel

Recommended Cutting Conditions



Machining data for SPADE-RUSH

ISO	Material	Condition	Tensile strength (N/mm ²)	Hardness HB	Material No.	Cutting speed Vc (m/min)		
P	Non-alloy steel, cast steel, free cutting steel	<0.25%C	Annealed	420	125	1	80-140	
		>=0.25%C	Annealed	650	190	2	80-130	
		<0.55%C	Quenched and tempered	850	250	3	80-120	
		>=0.55%C	Annealed	750	220	4	70-110	
			Quenched and tempered	1000	300	5	50-90	
	Low alloy steel and cast steel (Less than 5% of alloying elements)		Annealed		600	200	6	80-120
					930	275	7	70-110
			Quenched and tempered		1000	300	8	50-90
					1200	350	9	40-70
	High alloy steel, cast steel and tool steel		Annealed	680	200	10	50-90	
			Quenched and tempered	1100	325	11	40-80	
M	Stainless steel and cast steel	Ferritic / martensitic	680	200	12	40-70		
		Martensitic	820	240	13	40-70		
		Austenitic	600	180	14	30-70		
K	Gray cast iron (GG)	Ferritic		160	15	90-180		
		Pearlitic		250	16	80-140		
	Cast iron nodular (GGG)	Ferritic		180	17	90-165		
		Pearlitic		260	18	80-140		
	Malleable cast iron	Ferritic		130	19	90-160		
Pearlitic			230	20	80-140			
N	Aluminum - Wrought alloy	Not cureable		60	21	90-220		
		Cured		100	22	90-220		
	Aluminum-cast, alloyed	<=12% Si	Not cureable		75	23	90-220	
			Cured		90	24	90-220	
		>12% Si	High temp.		130	25	80-160	
	Copper alloys	>1% Pb	Free cutting		110	26	90-220	
			Brass		90	27	90-220	
			Electrolitic copper		100	28	90-220	
Non-metallic		Duroplastics, fiber plastics		70 Shore D	29			
		Hard rubber		55 Shore D	30			
S	High temp. alloys	Fe based	Annealed		200	31	30-60	
			Cured		280	32	20-50	
		Ni or Co based	Annealed		250	33	20-50	
			Cured		350	34	20-50	
			Cast		320	35	20-50	
	Titanium, Ti alloys	Pure	Rm 400	190	36	20-50		
Alpha+beta alloys cured		Rm 1050	310	37	20-50			
H	Hardened steel	Hardened		55HRC	38	20-50		
		Hardened		60HRC	39	20-50		
	Chilled cast iron	Cast		400	40			
	Cast iron nodular	Hardened		55HRC	41			

► For more information of material groups, see the materials & grades "material conversion table"

■ Steel
 ■ Stainless steel
 ■ Cast iron
 ■ Nonferrous
 ■ High temp. alloys
 ■ Hardened steel

Recommended Cutting Conditions



Machining data for SPADE-RUSH

Feed (mm/rev) vs. drill diameter						
Ø20 - Ø25.9		Ø26 - Ø29.9		Ø30 - Ø34.9		Ø35 - Ø41
LCD...-P	LCD...-P+	LCD...-P	LCD...-P+	LCD...-P	LCD...-P+	
0.30-0.50	0.25-0.45	0.30-0.50	0.30-0.50	0.30-0.50	0.30-0.50	0.35-0.55
0.30-0.50	0.25-0.45	0.30-0.50	0.30-0.50	0.30-0.50	0.30-0.50	0.35-0.55
0.30-0.50	0.25-0.45	0.30-0.50	0.30-0.50	0.30-0.50	0.30-0.50	0.35-0.55
0.30-0.50	0.25-0.45	0.30-0.50	0.30-0.50	0.30-0.50	0.30-0.50	0.35-0.55
0.30-0.50	0.25-0.45	0.30-0.50	0.30-0.50	0.30-0.50	0.30-0.50	0.35-0.55
0.25-0.45	0.20-0.40	0.25-0.45	0.25-0.45	0.25-0.45	0.25-0.45	0.30-0.50
0.25-0.45	0.20-0.40	0.25-0.45	0.25-0.45	0.25-0.45	0.25-0.45	0.30-0.50
0.25-0.45	0.20-0.40	0.25-0.45	0.25-0.45	0.25-0.45	0.25-0.45	0.30-0.50
0.25-0.45	0.20-0.40	0.25-0.45	0.25-0.45	0.25-0.45	0.25-0.45	0.30-0.50
0.25-0.35	0.20-0.30	0.25-0.35	0.25-0.35	0.25-0.35	0.25-0.35	0.30-0.40
0.25-0.35	0.20-0.30	0.25-0.35	0.25-0.35	0.25-0.35	0.25-0.35	0.30-0.40
0.15-0.30		0.15-0.30		0.15-0.30		0.20-0.35
0.15-0.30		0.15-0.30		0.15-0.30		0.20-0.35
0.15-0.30		0.15-0.30		0.15-0.30		0.20-0.35
0.35-0.55	0.30-0.50	0.35-0.55	0.35-0.55	0.35-0.55	0.35-0.55	0.40-0.60
0.35-0.55	0.30-0.50	0.35-0.55	0.35-0.55	0.35-0.55	0.35-0.55	0.40-0.60
0.35-0.55	0.30-0.50	0.35-0.55	0.35-0.55	0.35-0.55	0.35-0.55	0.40-0.60
0.35-0.55	0.30-0.50	0.35-0.55	0.35-0.55	0.35-0.55	0.35-0.55	0.40-0.60
0.35-0.55	0.30-0.50	0.35-0.55	0.35-0.55	0.35-0.55	0.35-0.55	0.40-0.60
0.35-0.55	0.30-0.50	0.35-0.55	0.35-0.55	0.35-0.55	0.35-0.55	0.40-0.60
0.40-0.60		0.40-0.60		0.40-0.60		0.50-0.70
0.40-0.60		0.40-0.60		0.40-0.60		0.50-0.70
0.40-0.60		0.40-0.60		0.40-0.60		0.50-0.70
0.40-0.60		0.40-0.60		0.40-0.60		0.50-0.70
0.40-0.60		0.40-0.60		0.40-0.60		0.50-0.70
0.40-0.60		0.40-0.60		0.40-0.60		0.50-0.70
0.40-0.60		0.40-0.60		0.40-0.60		0.50-0.70
0.40-0.60		0.40-0.60		0.40-0.60		0.50-0.70
0.10-0.20		0.10-0.20		0.15-0.25		0.15-0.25
0.10-0.20		0.10-0.20		0.15-0.25		0.15-0.25
0.10-0.20		0.10-0.20		0.15-0.25		0.15-0.25
0.10-0.20		0.10-0.20		0.15-0.25		0.15-0.25
0.10-0.20		0.10-0.20		0.15-0.25		0.15-0.25
0.10-0.20		0.10-0.20		0.15-0.25		0.15-0.25
0.10-0.20		0.10-0.20		0.15-0.25		0.15-0.25
0.10-0.20		0.10-0.20		0.15-0.25		0.15-0.25
0.10-0.20		0.10-0.20		0.15-0.25		0.15-0.25

Recommended Cutting Conditions



Machining data for SOLID-3-DRILL

ISO	Material	Condition	Tensile strength (N/mm ²)	Hardness HB	Material No.	Cutting speed Vc (m/min)	
P	Non-alloy steel, cast steel, free cutting steel	<0.25%C	Annealed	420	125	1	80-140
		>=0.25%C	Annealed	650	190	2	80-130
		<0.55%C	Quenched and tempered	850	250	3	80-120
		>=0.55%C	Annealed	750	220	4	70-110
			Quenched and tempered	1000	300	5	50-90
	Low alloy steel and cast steel (Less than 5% of alloying elements)		Annealed	600	200	6	80-120
			Quenched and tempered	930	275	7	70-110
				1000	300	8	50-90
				1200	350	9	40-70
	High alloy steel, cast steel and tool steel		Annealed	680	200	10	50-90
			Quenched and tempered	1100	325	11	40-80
M	Stainless steel and cast steel	Ferritic / martensitic	680	200	12		
		Martensitic	820	240	13		
		Austenitic	600	180	14		
K	Gray cast iron (GG)	Ferritic		160	15	80-140	
		Pearlitic		250	16	70-120	
	Cast iron nodular (GGG)	Ferritic		180	17	80-120	
		Pearlitic		260	18	70-110	
	Malleable cast iron	Ferritic		130	19	80-120	
Pearlitic			230	20	70-110		
N	Aluminum - Wrought alloy	Not cureable		60	21		
		Cured		100	22		
	Aluminum-cast, alloyed	<=12% Si	Not cureable		75	23	
			Cured		90	24	
		>12% Si	High temp.		130	25	
	Copper alloys	>1% Pb	Free cutting		110	26	
			Brass		90	27	
			Electrolitic copper		100	28	
Non-metallic		Duroplastics, fiber plastics		70 Shore D	29		
		Hard rubber		55 Shore D	30		
S	High temp. alloys	Fe based	Annealed		200	31	
			Cured		280	32	
		Ni or Co based	Annealed		250	33	
			Cured		350	34	
			Cast		320	35	
	Titanium, Ti alloys	Pure	Rm 400	190	36		
Alpha+beta alloys cured		Rm 1050	310	37			
H	Hardened steel	Hardened		55HRC	38		
		Hardened		60HRC	39		
	Chilled cast iron	Cast		400	40		
	Cast iron nodular	Hardened		55HRC	41		

► For more information of material groups, see the materials & grades "material conversion table"

■ Steel
 ■ Stainless steel
 ■ Cast iron
 ■ Nonferrous
 ■ High temp. alloys
 ■ Hardened steel

Recommended Cutting Conditions



Machining data for H-DRILL

ISO	Material	Condition	Tensile strength (N/mm ²)	Hardness HB	Material No.	Cutting speed Vc (m/min)	
P	Non-alloy steel, cast steel, free cutting steel	<0.25%C	Annealed	420	125	1	80-120
		>=0.25%C	Annealed	650	190	2	80-110
		<0.55%C	Quenched and tempered	850	250	3	70-100
		>=0.55%C	Annealed	750	220	4	70-100
			Quenched and tempered	1000	300	5	70-100
	Low alloy steel and cast steel (Less than 5% of alloying elements)	Quenched and tempered	Annealed	600	200	6	70-90
			930	275	7	70-90	
			1000	300	8	50-80	
			1200	350	9	40-70	
	High alloy steel, cast steel and tool steel	Annealed	680	200	10	50-80	
		Quenched and tempered	1100	325	11	40-70	
M	Stainless steel and cast steel	Ferritic / martensitic	680	200	12	30-60	
		Martensitic	820	240	13	30-60	
		Austenitic	600	180	14	30-60	
K	Gray cast iron (GG)	Ferritic		160	15	65-80	
		Pearlitic		250	16	65-80	
	Cast iron nodular (GGG)	Ferritic		180	17	85-105	
		Pearlitic		260	18	75-90	
	Malleable cast iron	Ferritic		130	19	65-80	
Pearlitic			230	20	65-80		
N	Aluminum - Wrought alloy	Not cureable		60	21	70-200	
		Cured		100	22	70-200	
	Aluminum-cast, alloyed	<=12% Si	Not cureable		75	23	70-200
			Cured		90	24	70-200
		>12% Si	High temp.		130	25	70-150
	Copper alloys	>1% Pb	Free cutting		110	26	70-200
		Brass			90	27	70-200
			Electrolytic copper		100	28	70-200
	Non-metallic		Duroplastics, fiber plastics		70 Shore D	29	
Hard rubber				55 Shore D	30		
S	High temp. alloys	Fe based	Annealed		200	31	15-40
			Cured		280	32	15-40
		Ni or Co based	Annealed		250	33	15-40
			Cured		350	34	15-40
			Cast		320	35	15-40
	Titanium, Ti alloys	Pure	Rm 400	190	36		
Alpha+beta alloys cured		Rm 1050	310	37			
H	Hardened steel	Hardened		55HRC	38	10-40	
		Hardened		60HRC	39	10-40	
	Chilled cast iron	Cast		400	40		
	Cast iron nodular	Hardened		55HRC	41		

► For more information of material groups, see the materials & grades "material conversion table"

■ Steel
 ■ Stainless steel
 ■ Cast iron
 ■ Nonferrous
 ■ High temp. alloys
 ■ Hardened steel

Recommended Cutting Conditions



Machining data for H-DRILL

Feed (mm/rev) vs. drill diameter		
Ø3 - Ø5	Ø5.1 - Ø8	Ø8.1 - Ø12
0.10-0.20	0.15-0.25	0.20-0.30
0.10-0.20	0.15-0.25	0.20-0.30
0.10-0.20	0.15-0.25	0.20-0.30
0.10-0.20	0.15-0.25	0.20-0.30
0.10-0.20	0.15-0.25	0.20-0.30
0.10-0.20	0.15-0.25	0.20-0.30
0.10-0.20	0.15-0.25	0.20-0.30
0.10-0.20	0.15-0.25	0.20-0.30
0.10-0.20	0.15-0.25	0.20-0.30
0.08-0.18	0.10-0.20	0.15-0.25
0.08-0.18	0.10-0.20	0.15-0.25
0.06-0.12	0.10-0.15	0.12-0.18
0.06-0.12	0.10-0.15	0.12-0.18
0.06-0.12	0.10-0.15	0.12-0.18
0.10-0.20	0.15-0.25	0.20-0.30
0.10-0.20	0.15-0.25	0.20-0.30
0.10-0.20	0.15-0.25	0.20-0.30
0.10-0.20	0.15-0.25	0.20-0.30
0.10-0.20	0.15-0.25	0.20-0.30
0.10-0.20	0.15-0.25	0.20-0.30
0.10-0.25	0.15-0.35	0.25-0.45
0.10-0.25	0.15-0.35	0.25-0.45
0.10-0.25	0.15-0.35	0.25-0.45
0.10-0.25	0.15-0.35	0.25-0.45
0.10-0.25	0.15-0.35	0.25-0.45
0.08-0.18	0.15-0.25	0.20-0.35
0.08-0.18	0.15-0.25	0.20-0.35
0.08-0.18	0.15-0.25	0.20-0.35
0.02-0.08	0.04-0.10	0.06-0.12
0.02-0.08	0.04-0.10	0.06-0.12
0.02-0.08	0.04-0.10	0.06-0.12
0.02-0.08	0.04-0.10	0.06-0.12
0.02-0.08	0.04-0.10	0.06-0.12
0.02-0.08	0.04-0.10	0.06-0.12
0.02-0.08	0.04-0.10	0.06-0.12

Recommended Cutting Conditions



Machining data for TBTA 3/5/7/9 & TBTA-R

ISO	Material	Condition	Tensile strength (N/mm ²)	Hardness HB	Material No.	Cutting speed Vc (m/min)	
P	Non-alloy steel, cast steel, free cutting steel	<0.25%C	Annealed	420	125	1	60-120
		>=0.25%C	Annealed	650	190	2	60-120
		<0.55%C	Quenched and tempered	850	250	3	60-120
		>=0.55%C	Annealed	750	220	4	60-120
			Quenched and tempered	1000	300	5	50-100
	Low alloy steel and cast steel (Less than 5% of alloying elements)		Annealed	600	200	6	50-100
			Quenched and tempered	930	275	7	50-100
				1000	300	8	50-100
				1200	350	9	50-100
	High alloy steel, cast steel and tool steel		Annealed	680	200	10	60-120
			Quenched and tempered	1100	325	11	60-120
M	Stainless steel and cast steel	Ferritic / martensitic	680	200	12	60-110	
		Martensitic	820	240	13	60-110	
		Austenitic	600	180	14	60-110	
K	Gray cast iron (GG)	Ferritic		160	15	60-100	
		Pearlitic		250	16	60-100	
	Cast iron nodular (GGG)	Ferritic		180	17	60-100	
		Pearlitic		260	18	60-100	
	Malleable cast iron	Ferritic		130	19	60-100	
Pearlitic			230	20	60-100		
N	Aluminum - Wrought alloy	Not cureable		60	21	60-130	
		Cured		100	22	60-130	
	Aluminum-cast, alloyed	<=12% Si	Not cureable		75	23	60-130
			Cured		90	24	60-130
		>12% Si	High temp.		130	25	60-130
	Copper alloys	>1% Pb	Free cutting		110	26	60-130
			Brass		90	27	60-130
			Electrolitic copper		100	28	60-130
	Non-metallic		Duroplastics, fiber plastics		70 Shore D	29	
Hard rubber				55 Shore D	30		
S	High temp. alloys	Fe based	Annealed		200	31	20-65
			Cured		280	32	20-65
		Ni or Co based	Annealed		250	33	20-65
			Cured		350	34	20-65
			Cast		320	35	20-65
	Titanium, Ti alloys		Pure	Rm 400	190	36	30-100
			Alpha+beta alloys cured	Rm 1050	310	37	30-100
H	Hardened steel	Hardened		55HRC	38		
		Hardened		60HRC	39		
	Chilled cast iron	Cast		400	40		
	Cast iron nodular	Hardened		55HRC	41		

► For more information of material groups, see the materials & grades "material conversion table"

■ Steel
 ■ Stainless steel
 ■ Cast iron
 ■ Nonferrous
 ■ High temp. alloys
 ■ Hardened steel

Recommended Cutting Conditions



Machining data for TBTA-FB

ISO	Material	Condition	Tensile strength (N/mm ²)	Hardness HB	Material No.	Cutting speed Vc (m/min)	
P	Non-alloy steel, cast steel, free cutting steel	<0.25%C	Annealed	420	125	1	70-130
		>=0.25%C	Annealed	650	190	2	70-130
		<0.55%C	Quenched and tempered	850	250	3	70-130
		>=0.55%C	Annealed	750	220	4	70-130
			Quenched and tempered	1000	300	5	70-130
	Low alloy steel and cast steel (Less than 5% of alloying elements)	Quenched and tempered	Annealed	600	200	6	70-120
			930	275	7	60-120	
			1000	300	8	60-120	
			1200	350	9	60-120	
	High alloy steel, cast steel and tool steel	Annealed	680	200	10	70-130	
		Quenched and tempered	1100	325	11	70-130	
M	Stainless steel and cast steel	Ferritic / martensitic	680	200	12	70-130	
		Martensitic	820	240	13	70-130	
		Austenitic	600	180	14	70-130	
K	Gray cast iron (GG)	Ferritic		160	15	60-110	
		Pearlitic		250	16	60-110	
	Cast iron nodular (GGG)	Ferritic		180	17	50-110	
		Pearlitic		260	18	50-110	
	Malleable cast iron	Ferritic		130	19	70-110	
Pearlitic			230	20	70-110		
N	Aluminum - Wrought alloy	Not cureable		60	21	65-130	
		Cured		100	22	65-130	
	Aluminum-cast, alloyed	<=12% Si	Not cureable		75	23	65-130
			Cured		90	24	65-130
		>12% Si	High temp.		130	25	65-130
	Copper alloys	>1% Pb	Free cutting		110	26	65-130
		Brass			90	27	65-130
			Electrolitic copper		100	28	65-130
	Non-metallic		Duroplastics, fiber plastics		70 Shore D	29	
Hard rubber				55 Shore D	30		
S	High temp. alloys	Fe based	Annealed		200	31	20-50
			Cured		280	32	20-50
		Ni or Co based	Annealed		250	33	20-50
			Cured		350	34	20-50
			Cast		320	35	20-50
	Titanium, Ti alloys	Pure	Rm 400	190	36	30-60	
		Alpha+beta alloys cured	Rm 1050	310	37	30-60	
H	Hardened steel	Hardened		55HRC	38		
		Hardened		60HRC	39		
	Chilled cast iron	Cast		400	40		
	Cast iron nodular	Hardened		55HRC	41		

► For more information of material groups, see the materials & grades "material conversion table"

■ Steel
 ■ Stainless steel
 ■ Cast iron
 ■ Nonferrous
 ■ High temp. alloys
 ■ Hardened steel

Recommended Cutting Conditions



Machining data for BTA & BTS

ISO	Material	Condition	Tensile strength (N/mm ²)	Hardness HB	Material No.	Cutting speed Vc (m/min)		
P	Non-alloy steel, cast steel, free cutting steel	<0.25%C	Annealed	420	125	1	70-120	
		>=0.25%C	Annealed	650	190	2	70-120	
		<0.55%C	Quenched and tempered	850	250	3	40-70	
		>=0.55%C	Annealed	750	220	4	70-120	
			Quenched and tempered	1000	300	5	55-100	
	Low alloy steel and cast steel (Less than 5% of alloying elements)		Annealed		600	200	6	70-100
					930	275	7	55-100
			Quenched and tempered		1000	300	8	55-100
					1200	350	9	55-100
	High alloy steel, cast steel and tool steel		Annealed	680	200	10	50-85	
			Quenched and tempered	1100	325	11	55-100	
M	Stainless steel and cast steel	Ferritic / martensitic	680	200	12	60-100		
		Martensitic	820	240	13	60-100		
		Austenitic	600	180	14	60-100		
K	Gray cast iron (GG)	Ferritic		160	15	60-100		
		Pearlitic		250	16	60-100		
	Cast iron nodular (GGG)	Ferritic		180	17	80-100		
		Pearlitic		260	18	80-100		
	Malleable cast iron	Ferritic		130	19	50-100		
Pearlitic			230	20	50-100			
N	Aluminum - Wrought alloy	Not cureable		60	21	65-130		
		Cured		100	22	65-100		
	Aluminum-cast, alloyed	<=12% Si	Not cureable		75	23	65-130	
			Cured		90	24	65-130	
		>12% Si	High temp.		130	25	65-130	
	Copper alloys	>1% Pb	Free cutting		110	26	65-130	
			Brass		90	27	65-130	
			Electrolitic copper		100	28	65-130	
	Non-metallic		Duroplastics, fiber plastics		70 Shore D	29		
			Hard rubber		55 Shore D	30		
S	High temp. alloys	Fe based	Annealed		200	31	10-50	
			Cured		280	32	10-50	
		Ni or Co based	Annealed		250	33	10-50	
			Cured		350	34	10-50	
			Cast		320	35	10-50	
	Titanium, Ti alloys	Pure	Rm 400	190	36	30-50		
Alpha+beta alloys cured		Rm 1050	310	37	30-50			
H	Hardened steel	Hardened		55HRC	38			
		Hardened		60HRC	39			
	Chilled cast iron	Cast		400	40			
	Cast iron nodular	Hardened		55HRC	41			

► For more information of material groups, see the materials & grades "material conversion table"

■ Steel
 ■ Stainless steel
 ■ Cast iron
 ■ Nonferrous
 ■ High temp. alloys
 ■ Hardened steel

Recommended Cutting Conditions



Machining data for WIN-GUN

ISO	Material	Condition	Tensile strength (N/mm ²)	Hardness HB	Material No.	Cutting speed Vc (m/min)	
P	Non-alloy steel, cast steel, free cutting steel	<0.25%C	Annealed	420	125	1	80-110-140
		>=0.25%C	Annealed	650	190	2	80-105-130
		<0.55%C	Quenched and tempered	850	250	3	80-100-120
		>=0.55%C	Annealed	750	220	4	70-90-110
			Quenched and tempered	1000	300	5	50-70-90
	Low alloy steel and cast steel (Less than 5% of alloying elements)	Quenched and tempered	Annealed	600	200	6	80-100-120
			930	275	7	70-90-110	
			1000	300	8	50-70-90	
			1200	350	9	40-55-70	
	High alloy steel, cast steel and tool steel	Annealed	680	200	10	50-70-90	
		Quenched and tempered	1100	325	11	40-60-80	
M	Stainless steel and cast steel	Ferritic / martensitic	680	200	12	40-55-70	
		Martensitic	820	240	13		
K	Gray cast iron (GG)	Ferritic		160	15	90-125-160	
		Pearlitic		250	16	80-110-140	
	Cast iron nodular (GGG)	Ferritic		180	17	90-135-180	
		Pearlitic		260	18	80-110-140	
	Malleable cast iron	Ferritic		130	19	90-125-160	
		Pearlitic		230	20	80-110-140	
N	Aluminum - Wrought alloy	Not cureable		60	21	90-155-220	
		Cured		100	22		
	Aluminum-cast, alloyed	<=12% Si	Not cureable		75		23
			Cured		90		24
		>12% Si	High temp.		130		25

► For more information of material groups, see the materials & grades "material conversion table"

■ Steel
 ■ Stainless steel
 ■ Cast iron
 ■ Nonferrous

Pressure and Coolant Flow Rate for WIN-GUN

Pressure (Bar)

Coolant Flow Rate (l/min)

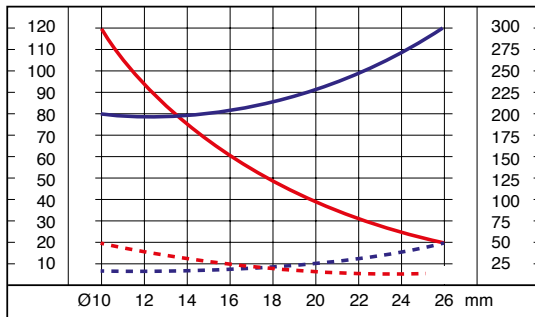

Drilling Diameter (mm)

Q (l/min) **P (bar)**
— — GUN-DRILL Machines
····· ····· Milling and Turning Machines

Recommended Cutting Conditions



Machining data for WIN-GUN

Feed (mm/rev) vs. drill diameter				
Ø10 - Ø11.9	Ø12 - Ø13.9	Ø14 - Ø15.9	Ø16 - Ø19.9	Ø20 - Ø25.9
0.15 0.18 0.21	0.18 0.21 0.24	0.20 0.23 0.27	0.25 0.30 0.35	0.25 0.30 0.35
0.14 0.17 0.21	0.16 0.20 0.24	0.18 0.22 0.26	0.23 0.27 0.31	0.25 0.30 0.35
0.12 0.14 0.17	0.15 0.17 0.20	0.18 0.20 0.23	0.20 0.22 0.25	0.22 0.24 0.27
0.12 0.13 0.15	0.14 0.15 0.17	0.16 0.18 0.20	0.16 0.19 0.21	0.18 0.21 0.24
0.20 0.23 0.27	0.25 0.28 0.32	0.30 0.33 0.37	0.35 0.40 0.45	0.35 0.42 0.47
0.25 0.28 0.32	0.30 0.33 0.37	0.35 0.38 0.42	0.40 0.45 0.50	0.45 0.50 0.57

- ▶ **Red text:** Recommended cutting data
- ▶ Mandatory use of emulsion or oil when drilling
- ▶ For the 400 mm long tools, please reduce the cutting speed by 20%

Recommended Cutting Conditions



Machining data for TRGD / TRGD3 / TRGDL / TBTA-TR

ISO	Material	Condition	Tensile strength (N/mm ²)	Hardness HB	Material No.		
P	Non-alloy steel, cast steel, free cutting steel	<0.25%C	Annealed	420	125	1	
		≥0.25%C	Annealed	650	190	2	
		<0.55%C	Quenched and tempered	850	250	3	
		≥0.55%C	Annealed	750	220	4	
			Quenched and tempered	1000	300	5	
	Low alloy steel and cast steel (Less than 5% of alloying elements)		Annealed	600	200	6	
			Quenched and tempered	930	275	7	
				1000	300	8	
				1200	350	9	
	High alloy steel, cast steel and tool steel		Annealed	680	200	10	
			Quenched and tempered	1100	325	11	
M	Stainless steel and cast steel	Ferritic / martensitic	680	200	12		
		Martensitic	820	240	13		
		Austenitic	600	180	14		
K	Gray cast iron (GG)	Ferritic		160	15		
		Pearlitic		250	16		
	Cast iron nodular (GGG)	Ferritic		180	17		
		Pearlitic		260	18		
	Malleable cast iron	Ferritic		130	19		
	Pearlitic		230	20			
N	Aluminum - Wrought alloy	Not cureable		60	21		
		Cured		100	22		
	Aluminum-cast, alloyed	≤12% Si	Not cureable		75	23	
			Cured		90	24	
		>12% Si	High temp.		130	25	
	Copper alloys		>1% Pb	Free cutting		110	26
				Brass		90	27
				Electrolitic copper		100	28
Non-metallic		Duroplastics, fiber plastics		70 Shore D	29		
		Hard rubber		55 Shore D	30		
S	High temp. alloys	Fe based	Annealed		200	31	
			Cured		280	32	
		Ni or Co based	Annealed		250	33	
			Cured		350	34	
	Titanium, Ti alloys		Cast		320	35	
			Pure	Rm 400	190	36	
		Alpha+beta alloys cured	Rm 1050	310	37		
H	Hardened steel		Hardened		55 HRC	38	
			Hardened		60 HRC	39	
	Chilled cast iron	Cast		400	40		
Cast iron nodular	Hardened			55 HRC	41		

► For more information of material groups, see the materials & grades "material conversion table"

■ Steel
 ■ Stainless steel
 ■ Cast iron
 ■ Nonferrous
 ■ High temp. alloys
 ■ Hardened steel

Recommended Cutting Conditions



Machining data for TRGD / TRGD3 / TRGD L / TBTA-TR

Feed (mm/rev) vs. drill diameter							
TRGD / TRGD3 / TRGD L						TBTA-TR	
Cutting speed Vc (m/min)	Ø10.00-Ø11.80	Ø12.00-Ø13.99	Ø14.00-Ø15.99	Ø16.00-Ø28.00	Ø28.01-Ø40.00	Cutting speed Vc (m/min)	Ø16.00-Ø28.00
80-140	0.05-0.08	0.05-0.10	0.05-0.10	0.05-0.10	0.05-0.15	90-130	0.15-0.20
80-140	0.05-0.14	0.05-0.16	0.05-0.10	0.05-0.10	0.05-0.15	90-130	0.15-0.20
80-140	0.05-0.14	0.05-0.16	0.05-0.16	0.05-0.20	0.05-0.20	90-130	0.15-0.20
80-140	0.05-0.14	0.05-0.16	0.05-0.16	0.05-0.20	0.05-0.20	70-130	0.10-0.25
80-140	0.05-0.14	0.05-0.16	0.05-0.16	0.05-0.20	0.05-0.20	70-130	0.10-0.25
80-140	0.05-0.14	0.05-0.16	0.05-0.10	0.05-0.10	0.05-0.15	70-120	0.10-0.25
80-120	0.05-0.14	0.05-0.16	0.05-0.16	0.05-0.20	0.05-0.20	60-120	0.10-0.25
80-120			0.05-0.16	0.05-0.20	0.05-0.20	60-120	0.10-0.25
80-120			0.05-0.16	0.05-0.20	0.05-0.20	60-120	0.10-0.25
80-140			0.05-0.10	0.05-0.10	0.05-0.15	70-130	0.10-0.25
80-120			0.05-0.16	0.05-0.20	0.05-0.20	70-130	0.10-0.25
60-100	0.05-0.08	0.05-0.10	0.05-0.10	0.05-0.10	0.05-0.15	80-130	0.06-0.10
60-100	0.05-0.08	0.05-0.10	0.05-0.10	0.05-0.10	0.05-0.15	80-130	0.06-0.10
60-100	0.05-0.08	0.05-0.10	0.05-0.10	0.05-0.10	0.05-0.15	80-130	0.06-0.10
80-140	0.05-0.20	0.05-0.25	0.05-0.25	0.05-0.30	0.05-0.30	50-110	0.10-0.20
80-140	0.05-0.20	0.05-0.25	0.05-0.25	0.05-0.30	0.05-0.30	50-110	0.10-0.20
80-140	0.05-0.20	0.05-0.25	0.05-0.25	0.05-0.30	0.05-0.30	60-110	0.10-0.20
80-140	0.05-0.20	0.05-0.25	0.05-0.25	0.05-0.30	0.05-0.30	60-110	0.10-0.20
80-140			0.05-0.25	0.05-0.30	0.05-0.30	70-110	0.10-0.20
80-140			0.05-0.25	0.05-0.30	0.05-0.30	70-110	0.10-0.20
100-200	0.05-0.18	0.05-0.20	0.05-0.20	0.05-0.20	0.05-0.25	65-130	0.08-0.18
100-200	0.05-0.18	0.05-0.20	0.05-0.20	0.05-0.20	0.05-0.25	65-130	0.08-0.18
100-200	0.05-0.18	0.05-0.20	0.05-0.20	0.05-0.20	0.05-0.25	65-130	0.08-0.18
100-200	0.05-0.18	0.05-0.20	0.05-0.20	0.05-0.20	0.05-0.25	65-130	0.08-0.18
						65-130	0.08-0.18
						65-130	0.08-0.18
						65-130	0.08-0.18
						65-130	0.08-0.18
						65-130	0.08-0.18
						65-130	0.08-0.18
20-50	0.04-0.06	0.04-0.08	0.04-0.08	0.04-0.10	0.04-0.13	20-50	0.08-0.18
20-50	0.04-0.06	0.04-0.08	0.04-0.08	0.04-0.10	0.04-0.13	20-50	0.08-0.18
20-50	0.04-0.06	0.04-0.08	0.04-0.08	0.04-0.10	0.04-0.13	20-50	0.08-0.18
20-50	0.04-0.06	0.04-0.08	0.04-0.08	0.04-0.10	0.04-0.13	20-50	0.08-0.18
20-50	0.04-0.06	0.04-0.08	0.04-0.08	0.04-0.10	0.04-0.13	20-50	0.08-0.18
30-60	0.04-0.10	0.05-0.13	0.05-0.13	0.05-0.15	0.05-0.18	30-60	0.08-0.18
30-60	0.04-0.10	0.05-0.13	0.05-0.13	0.05-0.15	0.05-0.18	30-60	0.08-0.18
50-100	0.04-0.06	0.04-0.08	0.04-0.08	0.04-0.10	0.04-0.13		
50-100	0.04-0.06	0.04-0.08	0.04-0.08	0.04-0.10	0.04-0.13		
50-100	0.04-0.06	0.04-0.08	0.04-0.08	0.04-0.10	0.04-0.13		
50-100	0.04-0.06	0.04-0.08	0.04-0.08	0.04-0.10	0.04-0.13		

Recommended Cutting Conditions



Machining data for XM-REAM

ISO	Material	Condition	Tensile strength (N/mm ²)	Hardness HB	Material No.	Cutting speed Vc (m/min)	Feed (mm/rev) vs. reamer diameter			
							Ø8-9.99	Ø10-11.99	Ø12-12.99	
P	Non-alloy steel, cast steel, free cutting steel	<0.25%C	Annealed	420	125	1	50-150	0.25-0.50	0.30-0.60	0.35-0.80
		>=0.25%C	Annealed	650	190	2	50-150	0.25-0.50	0.30-0.60	0.35-0.80
		<0.55%C	Quenched and tempered	850	250	3	50-150	0.25-0.50	0.30-0.60	0.35-0.80
		>=0.55%C	Annealed	750	220	4	50-150	0.25-0.50	0.30-0.60	0.35-0.80
			Quenched and tempered	1000	300	5	50-150	0.25-0.50	0.30-0.60	0.35-0.80
	Low alloy steel and cast steel (Less than 5% of alloying elements)	Annealed	600	200	6	50-150	0.25-0.50	0.30-0.60	0.35-0.80	
			930	275	7	50-150	0.25-0.50	0.30-0.60	0.35-0.80	
		Quenched and tempered	1000	300	8	50-150	0.25-0.50	0.30-0.60	0.35-0.80	
			1200	350	9	50-150	0.25-0.50	0.30-0.60	0.35-0.80	
	High alloy steel, cast steel and tool steel	Annealed	680	200	10	20-60	0.20-0.30	0.25-0.40	0.30-0.50	
		Quenched and tempered	1100	325	11	20-60	0.20-0.30	0.25-0.40	0.30-0.50	
M	Stainless steel and cast steel	Ferritic / martensitic	680	200	12	20-40	0.20-0.30	0.25-0.40	0.30-0.50	
		Martensitic	820	240	13	20-40	0.20-0.30	0.25-0.40	0.30-0.50	
		Austenitic	600	180	14	20-40	0.20-0.30	0.25-0.40	0.30-0.50	
K	Gray cast iron (GG)	Ferritic		160	15	50-200	0.30-0.60	0.35-0.80	0.40-1.00	
		Pearlitic		250	16	50-200	0.30-0.60	0.35-0.80	0.40-1.00	
	Cast iron nodular (GGG)	Ferritic		180	17	50-200	0.30-0.60	0.35-0.80	0.40-1.00	
		Pearlitic		260	18	50-200	0.30-0.60	0.35-0.80	0.40-1.00	
	Malleable cast iron	Ferritic		130	19	50-200	0.30-0.60	0.35-0.80	0.40-1.00	
Pearlitic			230	20	50-200	0.30-0.60	0.35-0.80	0.40-1.00		
N	Aluminum - Wrought alloy	Not cureable		60	21	100-250	0.30-0.60	0.35-0.80	0.40-1.00	
		Cured		100	22	100-250	0.30-0.60	0.35-0.80	0.40-1.00	
	Aluminum-cast, alloyed	<=12% Si	Not cureable		75	23	100-250	0.30-0.60	0.35-0.80	0.40-1.00
		Cured		90	24	100-250	0.30-0.60	0.35-0.80	0.40-1.00	
	>12% Si	High temp.		130	25	100-250	0.30-0.60	0.35-0.80	0.40-1.00	
	Copper alloys	>1% Pb	Free cutting		110	26	100-250	0.30-0.60	0.35-0.80	0.40-1.00
		Brass			90	27	100-250	0.30-0.60	0.35-0.80	0.40-1.00
			Electrolitic copper		100	28	100-250	0.30-0.60	0.35-0.80	0.40-1.00
	Non-metallic	Duroplastics, fiber plastics		70 Shore D	29					
		Hard rubber		55 Shore D	30					
S	High temp. alloys	Fe based	Annealed		200	31				
			Cured		280	32				
		Ni or Co based	Annealed		250	33				
			Cured		350	34				
			Cast		320	35				
	Titanium, Ti alloys	Pure	Rm 400	190	36					
Alpha+beta alloys cured		Rm 1050	310	37						
H	Hardened steel	Hardened		55 HRC	38					
		Hardened		60 HRC	39					
	Chilled cast iron	Cast		400	40					
	Cast iron nodular	Hardened		55 HRC	41					

► For more information of material groups, see the materials & grades "material conversion table"

■ Steel
 ■ Stainless steel
 ■ Cast iron
 ■ Nonferrous
 ■ High temp. alloys
 ■ Hardened steel

Recommended Cutting Conditions



Machining data for TM-REAM - Through hole

ISO	Material	Condition	Material No.	Through hole		Interrupted through Hole		
P	Non-alloy steel, cast steel, free cutting steel	<0.25%C	Annealed	1	TT9030	BL	TT9030	BL
		>=0.25%C	Annealed	2	Vc = 80 - 200		Vc = 60 - 120	
		<0.55%C	Quenched and tempered	3	B4 - B6	fz = 0.08 - 0.21	B4 - B6	fz = 0.08 - 0.21
		>=0.55%C	Annealed	4				
		Quenched and tempered	5	B7 - B9	fz = 0.12 - 0.27	B7 - B9	fz = 0.09 - 0.21	
	Low alloy steel and cast steel (Less than 5% of alloying elements)	Annealed	6	TT9030	BL	TT9030	BL	
		Quenched and tempered	7	Vc = 80 - 200		Vc = 60 - 120		
			8	B4 - B6	fz = 0.08 - 0.21	B4 - B6	fz = 0.08 - 0.21	
			9	B7 - B9	fz = 0.12 - 0.27	B7 - B9	fz = 0.09 - 0.21	
	High alloy steel, cast steel and tool steel	Annealed	10	TT9030	BL	TT9030	BL	
		Quenched and tempered	11	Vc = 20 - 60		Vc = 20 - 60		
			B4 - B6	fz = 0.05 - 0.13	B4 - B6	fz = 0.04 - 0.11		
			B7 - B9	fz = 0.07 - 0.17	B7 - B9	fz = 0.05 - 0.14		
M	Stainless steel and cast steel	Ferritic / martensitic	12	TT9030	BL	TT9030	BL	
				Vc = 20 - 40		Vc = 20 - 40		
		Martensitic	13	B4 - B6	fz = 0.05 - 0.13	B4 - B6	fz = 0.04 - 0.11	
	Austenitic	14	B7 - B9	fz = 0.07 - 0.17	B7 - B9	fz = 0.05 - 0.14		
K	Gray cast iron (GG)	Ferritic	15	TT9030	BL	TT9030	BL	
				Vc = 120 - 220		Vc = 80 - 200		
	Pearlitic	16	B4 - B6	fz = 0.08 - 0.18	B4 - B6	fz = 0.05 - 0.13		
			B7 - B9	fz = 0.10 - 0.24	B7 - B9	fz = 0.07 - 0.17		
	Cast iron nodular (GGG)	Ferritic	17	TT9030	AS or BL	TT9030	BL	
				Vc = 160 - 280		Vc = 150 - 250		
	Pearlitic	18	B4 - B6	fz = 0.11 - 0.20	B4 - B6	fz = 0.06 - 0.15		
			B7 - B9	fz = 0.11 - 0.24	B7 - B9	fz = 0.08 - 0.19		
Malleable cast iron	Ferritic	19	TT9030	AS or BL	TT9030	BL		
			Vc = 100 - 220		Vc = 100 - 220			
	Pearlitic	20	B4 - B6	fz = 0.11 - 0.20	B4 - B6	fz = 0.06 - 0.15		
			B7 - B9	fz = 0.11 - 0.24	B7 - B9	fz = 0.08 - 0.20		

► For more information of material groups, see the materials & grades "material conversion table"

■ Steel
 ■ Stainless steel
 ■ Cast iron
 ■ Nonferrous
 ■ High temp. alloys
 ■ Hardened steel

Recommended Cutting Conditions



Machining data for TM-REAM - Through hole

ISO	Material	Condition	Material No.	Through hole		Interrupted through Hole		
N	Aluminum - Wrought alloy	Not cureable	21	B7 - B9	BL or GS	UF10	BL	
		Cured	22	Vc = 150 - 400		Vc = 150 - 400		
	Aluminum-cast, alloyed	<=12% Si	Not cureable	23	B4 - B6	fz = 0.08 - 0.16	B4 - B6	fz = 0.08 - 0.16
			Cured	24				
		>12% Si	High temp.	25	B7 - B9	fz = 0.10 - 0.20	B7 - B9	fz = 0.10 - 0.20
	Copper alloys	>1% Pb	Free cutting	26	TT9030	BL	TT9030	BL
					Vc = 50 - 200		Vc = 50 - 200	
		Brass	27	B4 - B6	fz = 0.08 - 0.18	B4 - B6	fz = 0.05 - 0.13	
	Electrolytic copper		28	B7 - B9	fz = 0.10 - 0.23	B7 - B9	fz = 0.07 - 0.16	
	Non-metallic	Duroplastics, fiber plastics	29	TT9030	AS	TT9030	AS	
Vc = 25 - 80				Vc = 25 - 80				
Hard rubber			30	B4 - B6	fz = 0.05 - 0.10	B4 - B6	fz = 0.05 - 0.10	
S	High temp. alloys	Fe based	Annealed	31	TT9030	L *	TT9030	L *
			Cured	32	Vc = 15 - 50		Vc = 15 - 50	
		Ni or Co based	Annealed	33	B4 - B6	fz = 0.04 - 0.10	B4 - B6	fz = 0.03 - 0.08
	Cured		34					
	Cast		35					
	Titanium, Ti alloys	Pure	36	B7 - B9	fz = 0.05 - 0.13	B4 - B6	fz = 0.04 - 0.11	
Alpha+beta alloys cured		37						
H	Hardened steel	Hardened	38	TT9030	BL	TT9030	BL	
		Hardened	39	Vc = 25 - 50		Vc = 25 - 50		
	Chilled cast iron	Cast	40	B4 - B6	fz = 0.06 - 0.15	B4 - B6	fz = 0.06 - 0.15	
Cast iron nodular	Hardened	41	B7 - B9	fz = 0.10 - 0.20	B7 - B9	fz = 0.10 - 0.20		

* Standard edge geometries are not suitable for reaming titanium and high temperature alloys. In order to choose a proper geometry, please ask for our recommendations.

- ▶ The given cutting data recommendations refer to the short holders (3xD effective reaming overhang). For longer holders, the cutting speed to be reduced proportionally.
- ▶ For relatively large leading angles (spot-facing geometries), the feed to be reduced up to 30%.
- ▶ All the given cutting data recommendations refer to the machines with spindle through coolant supply.

Legend:

Grade	→	TT9030	BL	←	Cutting geometry
Cutting speed (m/min)	→	Vc = 10 - 20		←	Feed (mm/tooth)
TM-REAM head size	→	B4-B6	fz = 0.04 - 0.15	←	
		B7-B9	fz = 0.05 - 0.20		

Recommended Cutting Conditions



Machining data for TM-REAM - Blind hole

ISO	Material	Condition	Material No.	Blind hole		Interrupted blind hole		
P	Non-alloy steel, cast steel, free cutting steel	<0.25%C	Annealed	1	TT9030	AS	TT9030	AS
		>=0.25%C	Annealed	2	Vc = 60-160		Vc = 60 - 120	
		<0.55%C	Quenched and tempered	3	B4 - B6	fz = 0.06 - 0.18	B4 - B6	fz = 0.05 - 0.15
		>=0.55%C	Annealed	4				
			Quenched and tempered	5	B7 - B9	fz = 0.08 - 0.20	B7 - B9	fz = 0.07 - 0.16
	Low alloy steel and cast steel (Less than 5% of alloying elements)	Annealed	6	TT9030	AS	TT9030	AS	
		Quenched and tempered	7	Vc = 60-160		Vc = 60 - 120		
			8	B4 - B6	fz = 0.06 - 0.18	B4 - B6	fz = 0.05 - 0.15	
			9	B7 - B9	fz = 0.08 - 0.20	B7 - B9	fz = 0.07 - 0.16	
	High alloy steel, cast steel and tool steel	Annealed	10	TT9030	AS	TT9030	AS	
		Quenched and tempered	11	Vc = 20 - 60		Vc = 20 - 60		
			B4 - B6	fz = 0.04 - 0.10	B4 - B6	fz = 0.03 - 0.08		
M	Stainless steel and cast steel	Ferritic / martensitic	12	TT9030	AS	TT9030	AS	
				Vc = 20 - 40		Vc = 20 - 40		
		Martensitic	13	B4 - B6	fz = 0.04 - 0.10	B4 - B6	fz = 0.03 - 0.08	
		Austenitic	14	B7 - B9	fz = 0.05 - 0.13	B7 - B9	fz = 0.05 - 0.10	
K	Gray cast iron (GG)	Ferritic	15	TT9030	AS	TT9030	AS	
			Vc = 80 - 200		Vc = 60 - 120			
	Pearlitic	16	B4 - B6	fz = 0.06 - 0.18	B4 - B6	fz = 0.05 - 0.13		
			B7 - B9	fz = 0.08 - 0.23	B7 - B9	fz = 0.08 - 0.18		
	Cast iron nodular (GGG)	Ferritic	17	TT9030	AS	TT9030	AS	
			Vc = 160 - 280		Vc = 160 - 240			
	Pearlitic	18	B4 - B6	fz = 0.06 - 0.18	B4 - B6	fz = 0.06 - 0.16		
			B7 - B9	fz = 0.08 - 0.23	B7 - B9	fz = 0.08 - 0.18		
Malleable cast iron	Ferritic	19	TT9030	AS	TT9030	AS		
		Vc = 100 - 220		Vc = 100 - 220				
Pearlitic	20	B4 - B6	fz = 0.06 - 0.18	B4 - B6	fz = 0.05 - 0.15			
		B7 - B9	fz = 0.08 - 0.23	B7 - B9	fz = 0.08 - 0.20			

► For more information of material groups, see the materials & grades "material conversion table"

■ Steel
 ■ Stainless steel
 ■ Cast iron
 ■ Nonferrous
 ■ High temp. alloys
 ■ Hardened steel

Recommended Cutting Conditions



Machining data for TM-REAM - Blind hole

ISO	Material	Condition	Material No.	Blind hole		Interrupted blind hole		
N	Aluminum - Wrought alloy	Not cureable	21	UF10	GS or AS	UF10	GS or AS	
		Cured	22	Vc = 150 - 400		Vc = 150 - 300		
	Aluminum-cast, alloyed	<=12% Si	Not cureable	23	B4 - B6	fz = 0.08 - 0.16	B4 - B6	fz = 0.07 - 0.15
			Cured	24				
		>12% Si	High temp.	25	B7 - B9	fz = 0.11 - 0.20	B7 - B9	fz = 0.11 - 0.20
	Copper alloys	>1% Pb	Free cutting	26	TT9030	AS	TT9030	AS
					Vc = 50 - 200		Vc = 50 - 200	
		Brass	27	B4 - B6	fz = 0.08 - 0.16	B4 - B6	fz = 0.08 - 0.16	
	Electrolytic copper		28	B7 - B9	fz = 0.10 - 0.20	B7 - B9	fz = 0.10 - 0.20	
	Non-metallic	Duroplastics, fiber plastics	29	TT9030	AS	TT9030	AS	
				Vc = 25 - 80		Vc = 25 - 80		
			Hard rubber	30	B4 - B6	fz = 0.05 - 0.10	B4 - B6	fz = 0.05 - 0.10
S	High temp. alloys	Fe based	Annealed	31	TT9030	L *	TT9030	L *
			Cured	32	Vc = 15 - 50		Vc = 15 - 50	
		Ni or Co based	Annealed	33	B4 - B6	fz = 0.03 - 0.08	B4 - B6	fz = 0.03 - 0.08
	Cured		34					
	Cast		35					
	Titanium, Ti alloys	Pure	36	B7 - B9	fz = 0.04 - 0.11	B7 - B9	fz = 0.04 - 0.11	
Alpha+beta alloys cured		37						
H	Hardened steel	Hardened	38	TT9030	AS	TT9030	AS	
		Hardened	39	Vc = 25 - 50		Vc = 25 - 50		
	Chilled cast iron	Cast	40	B4 - B6	fz = 0.05 - 0.13	B4 - B6	fz = 0.05 - 0.13	
Cast iron nodular	Hardened	41	B7 - B9	fz = 0.10 - 0.20	B7 - B9	fz = 0.10 - 0.20		

* Standard edge geometries are not suitable for reaming titanium and high temperature alloys. In order to choose a proper geometry, please ask for our recommendations.

- ▶ The given cutting data recommendations refer to the short holders (3xD effective reaming overhang). For longer holders, the cutting speed to be reduced proportionally.
- ▶ For relatively large leading angles (spot-facing geometries), the feed to be reduced up to 30%.
- ▶ All the given cutting data recommendations refer to the machines with spindle through coolant supply.

Legend:

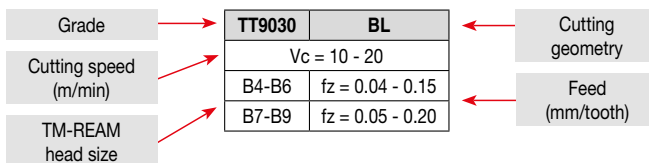

Recommended Cutting Conditions



Machining data for TB-REAM

			Lead A (15°/3°) (Reaming allowance: 0.1 ~ 0.3)						
			Feed (mm/rev)	Rake (°)	Cutting speed Vc (m/min)				
ISO	Material	Material No.			Carbide	Coated carbide	Cermet	PCD	CBN
P	Non-alloy steel and cast steel, free cutting steel	1 - 5	0.1-0.4	6	40-60	60-80	110-160		
	Low alloy steel and cast steel (Less than 5% of alloying elements)	6 - 9	0.1-0.4	6	20-40	40-60	110-160		
	High alloyed steel, cast steel and tool steel	10 - 11	0.1-0.4	6	20-40	20-60	20-60		
M	Stainless steel, cast steel	12 - 14	0.1-0.3	12	20-40	40-60	20-60		
K	Grey cast iron (GG)	15 - 16	0.1-0.3	0 / 6	40-60	60-100			Please ask
	Cast iron nodular (GGG)	17 - 18	0.1-0.3	0 / 6	40-60	60-100			
	Malleable cast iron	19 - 20	0.1-0.3	0 / 6	40-60	60-100			
N	Aluminum wrought alloy	21 - 22						Please ask	
	Aluminum-cast, alloyed	23 - 25							
	Copper alloys	26 - 28							
	Non-metallic	29 - 30							

			Lead C (75°) (Reaming allowance: 0.2 ~ 0.4)						
			Feed (mm/rev)	Rake (°)	Cutting speed Vc (m/min)				
ISO	Material	Material No.			Carbide	Coated carbide	Cermet	PCD	CBN
P	Non-alloy steel and cast steel, free cutting steel	1 - 5							
	Low alloy steel and cast steel (Less than 5% of alloying elements)	6 - 9							
	High alloyed steel, cast steel and tool steel	10 - 11							
M	Stainless steel, cast steel	12 - 14							
K	Grey cast iron (GG)	15 - 16							Please ask
	Cast iron nodular (GGG)	17 - 18							
	Malleable cast iron	19 - 20							
N	Aluminum wrought alloy	21 - 22	0.15-0.3	12	150-250			Please ask	
	Aluminum-cast, alloyed	23 - 25	0.15-0.3	12	150-250				
	Copper alloys	26 - 28							
	Non-metallic	29 - 30							

▶ The cutting conditions in the table below should be used to start a new application. Optimal conditions for a specific application should be evaluated by examining the results and changing the machining conditions accordingly.

▶ For more information of material groups, see the materials & grades "material conversion table"

■ Steel
 ■ Stainless steel
 ■ Cast iron
 ■ Nonferrous

Recommended Cutting Conditions



Machining data for TB-REAM

			Lead B (30°/3°) (Reaming allowance: 0.1 ~ 0.3)						
			Feed (mm/rev)	Rake (°)	Cutting speed Vc (m/min)				PCD
ISO	Material	Material No.			Carbide	Coated carbide	Cermet		
P	Non-alloy steel and cast steel, free cutting steel	1 - 5	0.1-0.4	6	60-80	80-120	110-160		
	Low alloy steel and cast steel (Less than 5% of alloying elements)	6 - 9	0.1-0.4	6	60-80	80-120	110-160		
	High alloyed steel, cast steel and tool steel	10 - 11	0.1-0.4	6	40-60	40-80	40-80		
M	Stainless steel, cast steel	12 - 14	0.1-0.3	12	40-60	60-80	60-80		
K	Grey cast iron (GG)	15 - 16	0.1-0.3	0 / 6	60-80	80-120			Please ask
	Cast iron nodular (GGG)	17 - 18	0.1-0.3	0 / 6	60-80	80-120			
	Malleable cast iron	19 - 20	0.1-0.3	0 / 6	60-80	80-120			
N	Aluminum wrought alloy	21 - 22		12	160-200			Please ask	
	Aluminum-cast, alloyed	23 - 25		12	160-200				
	Copper alloys	26 - 28		0	80-100				
	Non-metallic	29 - 30		0	10-70				

			Lead D (30°/3°) (Reaming allowance: 0.1 ~ 0.2)						
			Feed (mm/rev)	Rake (°)	Cutting speed Vc (m/min)				PCD
ISO	Material	Material No.			Carbide	Coated carbide	Cermet		
P	Non-alloy steel and cast steel, free cutting steel	1 - 5	0.1-0.4	6	60-80	80-120	110-160		
	Low alloy steel and cast steel (Less than 5% of alloying elements)	6 - 9	0.1-0.4	6	60-80	80-120	110-160		
	High alloyed steel, cast steel and tool steel	10 - 11	0.1-0.4	6	40-60	40-80	40-80		
M	Stainless steel, cast steel	12 - 14	0.1-0.3	12	40-60	60-80	60-80		
K	Grey cast iron (GG)	15 - 16	0.1-0.3	0 / 6	60-80	80-120			Please ask
	Cast iron nodular (GGG)	17 - 18	0.1-0.3	0 / 6	60-80	80-120			
	Malleable cast iron	19 - 20	0.1-0.3	0 / 6	60-80	80-120			
N	Aluminum wrought alloy	21 - 22		12	110-200			Please ask	
	Aluminum-cast, alloyed	23 - 25		12	160-200				
	Copper alloys	26 - 28		0	80-100				
	Non-metallic	29 - 30							

▶ The cutting conditions in the table below should be used to start a new application. Optimal conditions for a specific application should be evaluated by examining the results and changing the machining conditions accordingly.

▶ For more information of material groups, see the materials & grades "material conversion table"

■ Steel
 ■ Stainless steel
 ■ Cast iron
 ■ Nonferrous

Recommended Cutting Conditions



Machining data for TS-REAM

ISO	Material	Condition	Tensile strength (N/mm ²)	Hardness HB	Material No.	Cutting speed Vc (m/min)	
P	Non-alloy steel, cast steel, free cutting steel	<0.25%C	Annealed	420	125	1	120-250
		>=0.25%C	Annealed	650	190	2	120-250
		<0.55%C	Quenched and tempered	850	250	3	120-250
		>=0.55%C	Annealed	750	220	4	
			Quenched and tempered	1000	300	5	
	Low alloy steel and cast steel (Less than 5% of alloying elements)	Quenched and tempered	Annealed	600	200	6	120-250
			930	275	7	120-250	
			1000	300	8	120-250	
			1200	350	9	120-250	
	High alloy steel, cast steel and tool steel	Annealed	680	200	10	120-250	
		Quenched and tempered	1100	325	11	120-250	
M	Stainless steel and cast steel	Ferritic / martensitic	680	200	12	60-120	
		Martensitic	820	240	13	60-120	
		Austenitic	600	180	14	60-120	
K	Gray cast iron (GG)	Ferritic		160	15	60-120	
		Pearlitic		250	16	60-120	
	Cast iron nodular (GGG)	Ferritic		180	17	60-120	
		Pearlitic		260	18	60-120	
	Malleable cast iron	Ferritic		130	19	60-120	
Pearlitic			230	20	60-120		
N	Aluminum - Wrought alloy	Not cureable		60	21	250-500	
		Cured		100	22	250-500	
	Aluminum-cast, alloyed	<=12% Si	Not cureable		75	23	250-500
			Cured		90	24	250-500
		>12% Si	High temp.		130	25	
	Copper alloys	>1% Pb	Free cutting		110	26	
		Brass			90	27	
			Electrolitic copper		100	28	
Non-metallic		Duroplastics, fiber plastics		70 Shore D	29		
		Hard rubber		55 Shore D	30		
S	High temp. alloys	Fe based	Annealed		200	31	
			Cured		280	32	
		Ni or Co based	Annealed		250	33	25-50
			Cured		350	34	25-50
			Cast		320	35	
	Titanium, Ti alloys	Pure	Rm 400	190	36	30-80	
Alpha+beta alloys cured		Rm 1050	310	37	30-80		
H	Hardened steel	Hardened		55HRC	38	25-60	
		Hardened		60HRC	39		
	Chilled cast iron	Cast		400	40		
	Cast iron nodular	Hardened		55HRC	41		

► For more information of material groups, see the materials & grades "material conversion table"

■ Steel
 ■ Stainless steel
 ■ Cast iron
 ■ Nonferrous
 ■ High temp. alloys
 ■ Hardened steel

► Chamfering ring design - DRILL-RUSH

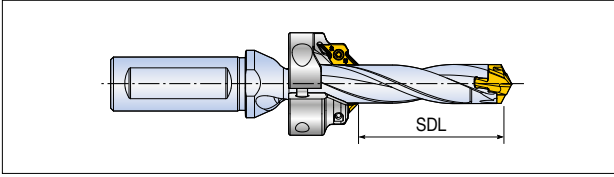

	Designation	CFR designation	SDL	
			min	max
3D	TCD 130-134-16T3/S0-3D	CFR D130-A45	19	19
	135-139-16T3/S0-3D	CFR D135-A45	19	20
	140-144-16T3/S0-3D	CFR D140-A45	21	22
	145-149-16T3/S0-3D	CFR D145-A45	22	23
	150-159-20T3/S0-3D	CFR D150-A45	23	23
	160-169-20T3/S0-3D	CFR D160-A45	24	25
	170-179-20T3/S0-3D	CFR D170-A45	26	28
	180-189-25T2/S0-3D	CFR D180-A45	27	30
	190-199-25T2/S0-3D	CFR D190-A45	29	33
	200-209-25T2/S0-3D	CFR D200-A45	30	36
	210-219-25T2/S0-3D	CFR D210-A45	32	39
	220-229-25T2/S0-3D	CFR D220-A45	33	42
	230-239-32T2/S0-3D	CFR D230-A45	35	45
240-249-32T2/S0-3D	CFR D240-A45	36	48	
250-259-32T2/S0-3D	CFR D250-A45	38	51	
5D	TCD 100-104-16T3/S0-5D	CFR D100-A45	28	28
	105-109-16T3/S0-5D	CFR D105-A45	29	30
	110-114-16T3/S0-5D	CFR D110-A45	31	33
	115-119-16T3/S0-5D	CFR D115-A45	32	35
	120-124-16T3/S0-5D	CFR D120-A45	33	45
	125-129-16T3/S0-5D	CFR D125-A45	34	40
	130-134-16T3/S0-5D	CFR D130-A45	36	43
	135-139-16T3/S0-5D	CFR D135-A45	37	43
	140-144-16T3/S0-5D	CFR D140-A45	38	48
	145-149-16T3/S0-5D	CFR D145-A45	39	48
	150-159-20T3/S0-5D	CFR D150-A45	41	53
	160-169-20T3/S0-5D	CFR D160-A45	43	58
	170-179-20T3/S0-5D	CFR D170-A45	46	63
	180-189-25T2/S0-5D	CFR D180-A45	48	68
	190-199-25T2/S0-5D	CFR D190-A45	51	73
200-209-25T2/S0-5D	CFR D200-A45	53	78	
210-219-25T2/S0-5D	CFR D210-A45	56	79	
220-229-25T2/S0-5D	CFR D220-A45	58	84	
230-239-32T2/S0-5D	CFR D230-A45	61	89	
240-249-32T2/S0-5D	CFR D240-A45	63	94	
250-259-32T2/S0-5D	CFR D250-A45	66	99	

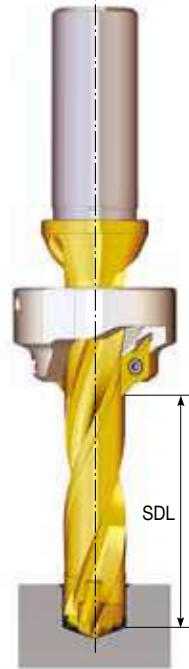

► Chamfering ring designation - DRILL-RUSH

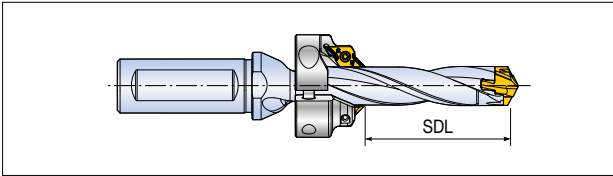

	Designation	CFR designation	SDL	
			min	max
8D	TCD 100-104-16T3/S0-8D	CFR D100-A45	45	58
	105-109-16T3/S0-8D	CFR D105-A45	49	62
	110-114-16T3/S0-8D	CFR D110-A45	49	66
	115-119-16T3/S0-8D	CFR D115-A45	53	70
	120-124-16T3/S0-8D	CFR D120-A45	53	74
	125-129-16T3/S0-8D	CFR D125-A45	57	78
	130-134-16T3/S0-8D	CFR D130-A45	57	82
	135-139-16T3/S0-8D	CFR D135-A45	61	84
	140-144-16T3/S0-8D	CFR D140-A45	61	88
	145-149-16T3/S0-8D	CFR D145-A45	65	92
	150-159-20T3/S0-8D	CFR D150-A45	65	96
	160-169-20T3/S0-8D	CFR D160-A45	69	103
	170-179-20T3/S0-8D	CFR D170-A45	73	111
	180-189-25T2/S0-8D	CFR D180-A45	77	118
	190-199-25T2/S0-8D	CFR D190-A45	81	126
	200-209-25T2/S0-8D	CFR D200-A45	85	134
	210-219-25T2/S0-8D	CFR D210-A45	89	142
	220-229-25T2/S0-8D	CFR D220-A45	93	150
230-239-32T2/S0-8D	CFR D230-A45	97	158	
240-249-32T2/S0-8D	CFR D240-A45	101	166	
250-259-32T2/S0-8D	CFR D250-A45	105	174	
12D	TCD 120-124-16S0-12D	CFR D120-A45	87	121
	125-129-16S0-12D	CFR D125-A45	90	127
	130-134-16S0-12D	CFR D130-A45	93	133
	135-139-16S0-12D	CFR D135-A45	96	137
	140-144-16S0-12D	CFR D140-A45	99	143
	145-149-16S0-12D	CFR D145-A45	102	149
	150-159-20S0-12D	CFR D150-A45	105	155
	160-169-20S0-12D	CFR D160-A45	111	166
	170-179-20S0-12D	CFR D170-A45	117	178
	180-189-25S0-12D	CFR D180-A45	123	189
	190-199-25S0-12D	CFR D190-A45	129	201
	200-209-25S0-12D	CFR D200-A45	135	213
210-219-25S0-12D	CFR D210-A45	141	225	
220-229-25S0-12D	CFR D220-A45	147	237	

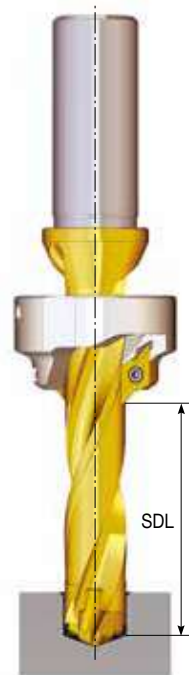

► Modular head replacement instructions

1. Remove both outer inserts, then remove the center drill head.
(When clamping, go in the reverse order)
2. Use a wrench to turn the screw counter-clock-wise to remove the modular head.
3. Insert the setting gauge into the bottom of the disconnected modular head.

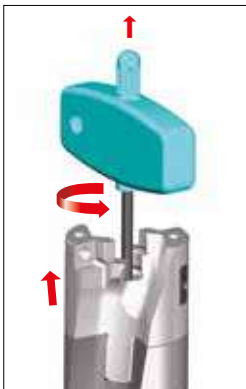

4. Rotate the screw to adjust to the same height with the setting gauge.

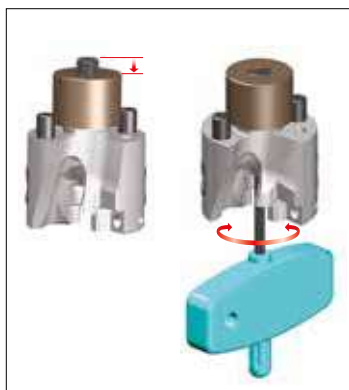

Setting gauge

Drill dia.	Designation
D26-D29	SG TNDH D26-29-TP
D30-D35	SG TNDH D30-35-TP
D36-D39	SG TNDH D36-39-TP
D40-D43	SG TNDH D40-43-TP
D44-D50	SG TNDH D44-50-TP

5. Remove the height adjusted modular head from the setting gauge and attach it to the holder.

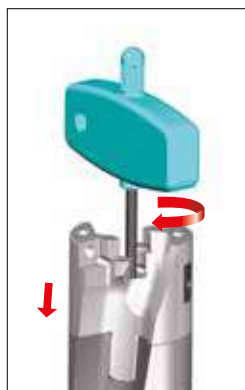

► Modular head disassembly in the event of center drill damage

If the modular head cannot be unclamped due to center drill damage, insert the wrench into the rear section of the shank. Then, turn it clock-wise to disassemble the modular head.

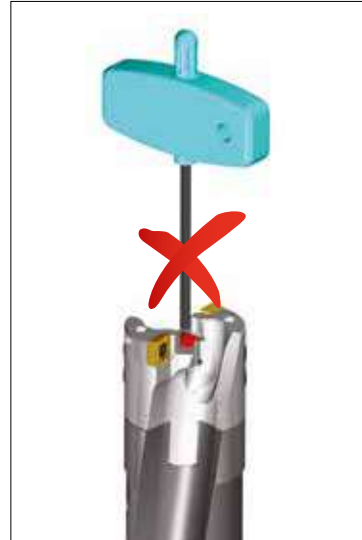

Damaged center drill



► Disassembling wrench and handle are included with the modular drill holder. (MDB Dxx/xx...)

► XM-REAM user guide and notice

How to check reamer diameter

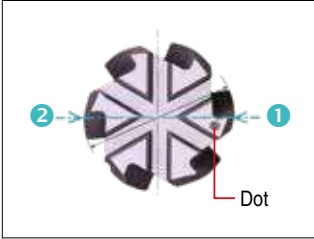

Measure the dot side edge **1** and opposite side edge **2**.

Reaming allowance

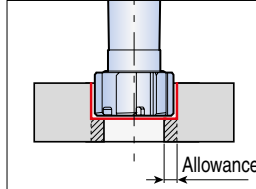

Material	Diameter	
	< Ø10	Ø10-12
Steel & Cast iron	0.07-0.10	0.07-0.15
Aluminum & brass	0.07-0.10	0.10-0.15

* Based on diameter

Ex) Ø9.85-9.93 mm pre-hole is recommended for Ø10H7 reaming in cast iron.

Caution

- To ensure smooth coolant flow, the dot and slot orientation of the head must be aligned as illustrated.

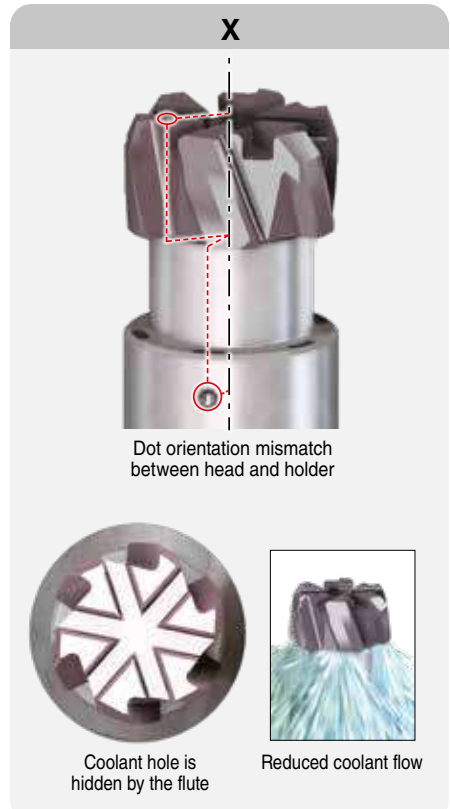
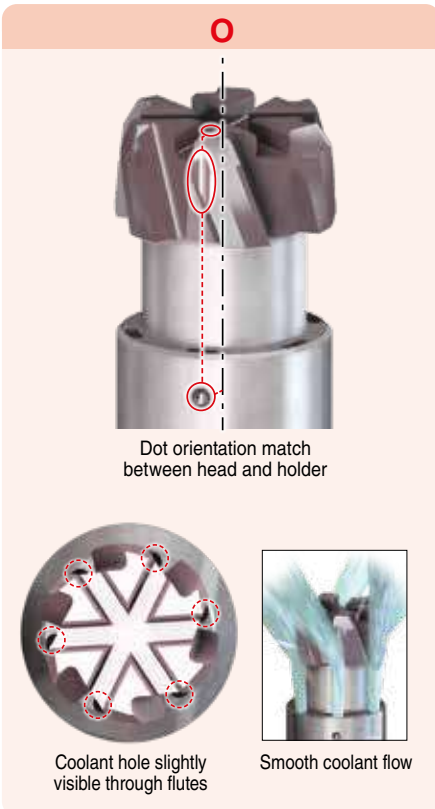

► Screw torque

For SPADE-RUSH

Designation	Thread	Length	Torx	Tightening Torque
TS 30138D33	M3	13.8	Torx 10	2.0 Nm
TS 40178D25	M4	17.8	Torx 20	4.5 Nm
TS 40198D28	M4	19.8	Torx 20	4.5 Nm
TS 40210D3	M4	21	Torx 20	5.0 Nm
TS 50230D3	M5	23	Torx 20	5.0 Nm
TS 50250D35	M5	25	Torx 25	5.5 Nm
TS 60265D4	M6	26.5	Torx 25	6.0 Nm
TS 60285D42	M6	28.5	Torx 25	6.0 Nm
TS 60320D5	M6	31	Torx 25	6.0 Nm
TS 80340D6	M8	34	Torx 25	7.0 Nm

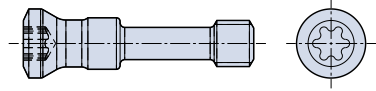

For MODU-R-DRILL

Designation	Thread	Length	Torx	Tightening Torque
TDPS 0512-T7	M5	12	Torx 7	1.0 Nm
TDPS 0618-T8	M6	18	Torx 8	2.0 Nm

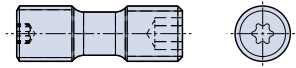

For MODU-R-DRILL

Designation	Thread	Length	Torx	Tightening Torque
TDPS 0722-W3.0	M7	22	Hexa 3.0 mm	5.0 Nm

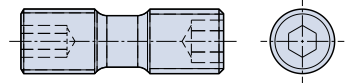

Technical Data

► Hole tolerance

Diameter D(mm)		Tolerance (µm)															
>D	≤D	B10	C9	C10	D8	D9	D10	E7	E8	E9	F6	F7	F8	G6	G7	H6	H7
-	3	+180 +140	+85 +60	+100 +60	+34 +20	+45 +20	+60 +20	+24 +14	+28 +14	+39 +14	+12 +6	+16 +6	+20 +6	+8 +2	+12 +2	+6 0	+10 0
3	6	+180 +140	+100 +70	+118 +70	+48 +30	+60 +30	+78 +30	+32 +20	+38 +20	+50 +20	+18 +10	+22 +10	+28 +10	+12 +4	+16 +4	+8 0	+12 0
6	10	+208 +150	+116 +80	+138 +80	+62 +40	+76 +40	+98 +40	+40 +25	+47 +25	+61 +25	+22 +13	+28 +13	+35 +13	+14 +5	+20 +5	+9 0	+15 0
10	14	+220 +150	+138 +95	+165 +95	+77 +50	+93 +50	+120 +50	+50 +32	+59 +32	+75 +32	+27 +16	+34 +16	+43 +16	+17 +6	+24 +6	+11 0	+18 0
14	18																
18	24	+244 +160	+162 +110	+194 +110	+98 +65	+117 +65	+149 +65	+61 +40	+73 +40	+92 +40	+33 +20	+41 +20	+53 +20	+20 +7	+28 +7	+13 0	+21 0
24	30																
30	40	+270 +170	+182 +120	+220 +120	+119 +80	+142 +80	+180 +80	+75 +50	+89 +50	+112 +50	+41 +25	+50 +25	+64 +25	+25 +9	+34 +9	+16 0	+25 0
40	50	+280 +180	+192 +130	+230 +130													
50	65	+310 +190	+214 +140	+260 +140	+146 +100	+174 +100	+220 +146	+90 +60	+106 +60	+134 +60	+49 +30	+60 +30	+76 +30	+29 +10	+40 +10	+19 0	+30 0
65	80	+320 +200	+224 +150	+270 +150													



Technical Data

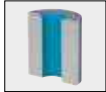
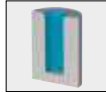

► Hole tolerance

Tolerance (µm)																		
H8	H9	H10	JS6	JS7	K6	K7	M6	M7	N6	N7	P6	P7	R7	S7	T7	U7	X7	
+14 0	+25 0	+40 0	±3	±5	0 -6	0 -10	-2 -8	-2 -12	-4 -10	-4 -14	-6 -12	-6 -16	-10 -20	-14 -24	-	-18 -28	-20 -30	
+18 0	+30 0	+48 0	±4	±6	+2 -6	+3 -9	-1 -9	0 -12	-5 -13	-4 -16	-9 -17	-8 -20	-11 -23	-15 -27	-	-19 -31	-24 -36	
+22 0	+36 0	+58 0	±4.5	±7.5	+2 -7	+5 -10	-3 -12	0 -15	-7 -16	-4 -19	-12 -21	-9 -24	-13 -28	-17 -32	-	-22 -37	-28 -43	
+27 0	+43 0	+70 0	±5.5	±9	+2 -9	+6 -12	-4 -15	0 -18	-9 -20	-5 -23	-15 -26	-11 -29	-16 -34	-21 -39	-	-26 -44	-33 -51 -38 -56	
+33 0	+52 0	+84 0	±6.5	±10.5	+2 -11	+6 -15	-4 -17	0 -21	-11 -24	-7 -28	-18 -31	-14 -35	-20 -41	-27 -48	-	-33 -54 -40 -61	-46 -67 -56 -77	
+39 0	+62 0	+100 0	±8	±12.5	+3 -13	+7 -18	-4 -20	0 -25	-12 -28	-8 -33	-21 -37	-17 -42	-25 -50	-34 -59	-39 -64 -45 -70	-51 -76 -61 -86	-	
+46 0	+74 0	+120 0	±9.5	±15	+4 -15	+9 -21	-5 -24	0 -30	-14 -33	-9 -39	-26 -45	-21 -51	-30 -60 -32 -62	-42 -72 -48 -78	-55 -85 -64 -94	-76 -106 -91 -121	-	

► Specific dimensions

	<div style="display: flex; justify-content: space-around;"> <div style="text-align: center;">  </div> <div style="text-align: center;">  </div> </div> <p>Through <input type="checkbox"/> Blind <input type="checkbox"/></p> <p>ØD1 _____ L1 _____</p> <p>α1 _____ S _____</p> <p>•Hole tolerance _____</p>
--	--

	<div style="display: flex; justify-content: space-around;"> <div style="text-align: center;">  </div> <div style="text-align: center;">  </div> </div> <p>Through <input type="checkbox"/> Blind <input type="checkbox"/></p> <p>ØD1 _____ ØD2 _____</p> <p>L1 _____ L2 _____</p> <p>α1 _____</p> <p>•Hole tolerance _____</p>
--	--

	<div style="display: flex; justify-content: space-around;"> <div style="text-align: center;">  </div> <div style="text-align: center;">  </div> </div> <p>Through <input type="checkbox"/> Blind <input type="checkbox"/></p> <p>ØD1 _____ ØD2 _____</p> <p>L1 _____ L2 _____</p> <p>α1 _____ α2 _____</p> <p>S _____</p> <p>•Hole tolerance _____</p>
--	--

<div style="border: 1px solid black; padding: 5px; margin-bottom: 5px;"> <p>Comment</p> </div> <div style="border: 1px solid black; height: 150px; width: 100%;"></div>

Drill type

- TOPDRILL _____
- T-DRILL _____

Technical data





- Machine type
- MCT Lathe
- Vertical Horizontal
- Machine name _____
- Power _____ kW

- Coolant supply
- Internal External
- Coolant pressure _____ bar
- Coolant type _____

Workpiece

- Part _____
- Material _____
- Hardness _____

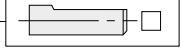
Shank type

- 
Cylindrical shank (ISO 9766)
- 
Whistle notch shank
- 
Cylindrical with flat type
- 
Weldon shank

► Specific dimensions

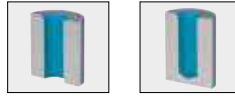
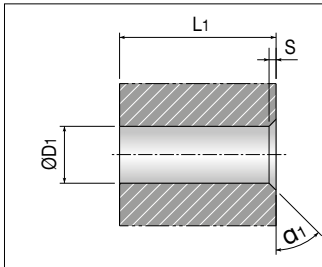

Through Blind
 ØD1 _____ L1 _____
 Q1 _____ S _____
 •Hole tolerance _____

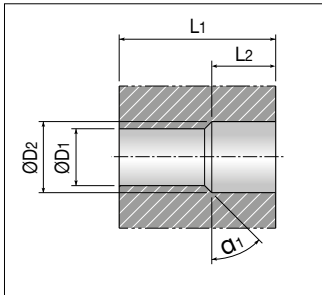

Through Blind
 ØD1 _____ ØD2 _____
 L1 _____ L2 _____
 Q1 _____
 •Hole tolerance _____

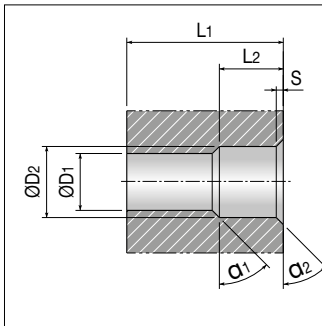

Through Blind
 ØD1 _____ ØD2 _____
 L1 _____ L2 _____
 Q1 _____ Q2 _____
 S _____
 •Hole tolerance _____

Comment

Technical data

- Machine type
 MCT Lathe
 Vertical Horizontal
 Machine name _____
 Power _____ kW
- Coolant supply
 Internal External
 Coolant pressure _____ bar
 Coolant type _____

Workpiece

- Part _____
- Material _____
- Hardness _____

Shank type

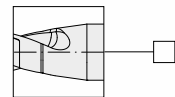
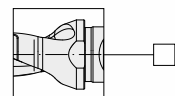
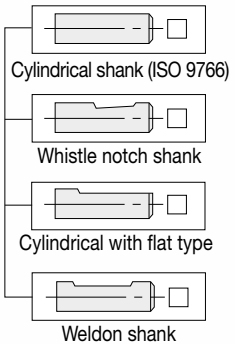

- Shank dia: _____
- Shank length: _____

► Specific dimensions

• DC, DC_2 would be hole dimensions and please note hole tolerance if possible

Technical data

- Machine type
 - MCT Lathe
 - Vertical Horizontal
 - Machine name _____
 - Power _____ kW
- Coolant supply
 - Internal External
 - Coolant pressure _____ bar
 - Coolant type _____

Workpiece

- Part _____
- Material _____
- Hardness _____

Hole type

- Blind hole
- Through hole

Coating

- TiAlN
- Non-coated

Shank type

- Cylindrical shank
- Whistle notch shank
- Cylindrical with flat type
- Weldon shank

Comment

Tailor-made Order Form



► Deep hole drilling order form

★: Mandatory data field

Company name :	Inquiry number :
Address :	Inquiry date :
Contact person :	Customer No. :

Workpiece (If possible, please attach a drawing)	
Product name	
Hole diameter (ø)	(mm)
Hole depth (drilling length)	(mm)
No. of holes	
Tolerance (of hole)	
Surface finish (Rz, Ra...)	
Deviation (mm/100)	
Straightness (mm/100)	
Material	
Material (DIN, AISI, JIS...)	
Hardness (HB, HS, HRC...)	
Condition★	<input type="checkbox"/> Annealed <input type="checkbox"/> Quenched <input type="checkbox"/> Tempered <input type="checkbox"/> Cast <input type="checkbox"/> <input type="checkbox"/> Other <input type="checkbox"/>

Machine	
Machine supplier name	
Machine type/model	
Rigidity	<input type="checkbox"/> Good <input type="checkbox"/> Normal <input type="checkbox"/> Bad
Date of manufacture	
Retrofitted	<input type="checkbox"/> NC lathe <input type="checkbox"/> M/C <input type="checkbox"/> Other
Double rotation (TR/WR)	<input type="checkbox"/> Tool and workpiece
Rotating workpiece (WR)	<input type="checkbox"/>
Rotating tool (TR)	<input type="checkbox"/>
Safety devices	
Motor power	(kW)

Type of coolant	
Coolant supplier name	
Water based	<input type="checkbox"/> Soluble <input type="checkbox"/> Emulsion %
Oil based	<input type="checkbox"/>
Coolant pressure	(bar)
Coolant volume	(L/min)

Tailor-made Order Form



► Deep hole drilling order form

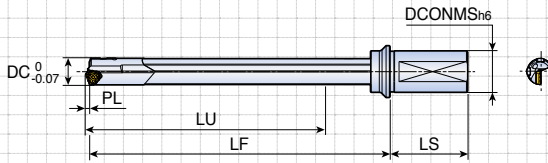

Sketch of drilling application

• Note: It may be necessary to change several of the parameters that you indicated based on our experience with your application.

Tool	
Quantity	
Nominal diameter and tolerance	
- Please fill in dimensions on the sketch above.	
Driver	
Code No	

- For standard drivers, please use codes from next pages and for special drivers, please attach sketch and specifications.

Workpiece (If possible, please attach a drawing)	
Material description (DIN material number or any other standard)	
Hardness and properties	
Hole type	<input type="checkbox"/> Blind hole <input type="checkbox"/> Through hole <input type="checkbox"/> Drilling into pre-hole
	<input type="checkbox"/> Angled entry <input type="checkbox"/> Drilling into solid <input type="checkbox"/> Boring
	<input type="checkbox"/> Angled exit
Drilling depth	mm
Hole tolerance	
Application	Workpiece <input type="checkbox"/> Stationary <input type="checkbox"/> Rotating
	Tool <input type="checkbox"/> Stationary <input type="checkbox"/> Rotating

Machine	
Machine type	
Power kW	
Cutting data	Cutting speed (Vc) m/min
	Revolutions Nmin : RPM Nmax : RPM
	Feed Fmin : mm/rev Fmin : mm/rev
	Feed rate (VF) mm/min
Coolant	Coolant type <input type="checkbox"/> Oil <input type="checkbox"/> Soluble oil <input type="checkbox"/> Other
	Coolant pressure Bar
	Coolant volume liter/min

► Standard gundrill drivers for machining centers and lathes

Drivers

Drivers are available for dedicated and CNC machines as well as any specified diameter or length. Please note that the driver codes and technical data can be found in the chart below.

Driver type	Drawing	DCONMS x LS	Driver code
Cylindrical DIN1835A DIN6535HA		20x50	10
		25x56	11
		32x60	12
		40x70	13
		.75x2.03"	95
		1.00x2.28"	96
		1.25x2.28"	97
Weldon DIN1835B DIN6535HB		20x50	22
		25x56	23
		32x60	24
		40x70	25
		.75x2.03"	99
		1.00x2.28"	100
Whistle notch DIN1835E		20x50	34
		25x56	35
		32x60	36
		40x70	37

► Standard drivers for gundrill machines









Driver type	Drawing	DCONMS x LS	Driver code
DIN228AK		CM2	46
		CM3	47
		CM4	48
DIN228BK		CM2	50
		CM3	51
		CM4	52
Central clamping surface 15°		.750x2.75"	56
		25x70	57
		1.00x2.75"	58
		1.25x2.75"	59
		1.50x2.75"	60
Frontal clamping surface 15°		16x50	61
Cylindrical with thread		25x100 M16x1.5	66
		36x120 M24x1.5	67
VDI design		25x112 M16x1.5	70
		36x135 M24x1.5	71
Central clamping hexagonal		25x70	72
		32x70	73
Central clamping tapered		.75x2.75"	76
		20x70	77
Frontal clamping surface 2°		1.00x2.75"	80
		1.00x3.94"	81
		1.25x2.75"	82
		1.25x3.94"	83
		1.50x2.75"	84
		1.50x3.94"	85
Trapezoidal thread		28x126 Tr 28x2	88
		36x162 Tr 36x2	89
Spraymist driver		25x50	91
		35x60	92

► Reamer order form

★: Mandatory data field

Date:	Subsidiary:
Company★ :	Enquiry dead line:
Contact person:	
Address:	

Request reason	
New tool <input type="checkbox"/>	Problem <input type="checkbox"/>
Quality	
Cycle time	
Alternative supplier	
Other	

Workpiece	
Description★	
Hardness★	
Pre-hole size★	(Tolerance :)
Depth★	
Bore type	
<input type="checkbox"/>  <input type="checkbox"/>  <input type="checkbox"/>  <input type="checkbox"/>  <input type="checkbox"/> 	
<input type="checkbox"/>  <input type="checkbox"/>  <input type="checkbox"/>  <input type="checkbox"/> 	
Clamping information	

Existing tool	
Maker	
Tool type	
Speed & Feed	
Tool life	
No of teeth	
Coolant type	

Machine	
Model	
Type★	vertical <input type="checkbox"/>
	horizontal <input type="checkbox"/>
	multi-spindle <input type="checkbox"/>
Adaption★	
Max RPM	
Power	
Spindle accuracy	
Coolant	

Lubricant	
Oil	<input type="checkbox"/>
MQL	<input type="checkbox"/>
Emulsion	<input type="checkbox"/>
Ratio of mixture	
Coolant pressure	

Quality requirement	
Tolerance★	
Surface finish(Ra)★	
Roundness	
Straightness	
Cylindricity	
Concentricity	

Tool	
Type★	TM(Index multi-edge) <input type="checkbox"/> TB(Single blade) <input type="checkbox"/> TS(Solid) <input type="checkbox"/> Other <input type="checkbox"/> ()
Diameter★	
Depth of cut★	
Coolant★	Internal <input type="checkbox"/> External <input type="checkbox"/>
Shank type★	
Holder type	Collet <input type="checkbox"/> Hydraulic <input type="checkbox"/> Other <input type="checkbox"/>
Adjustable adaptor	Yes <input type="checkbox"/> No <input type="checkbox"/>

MATERIALS & GRADES

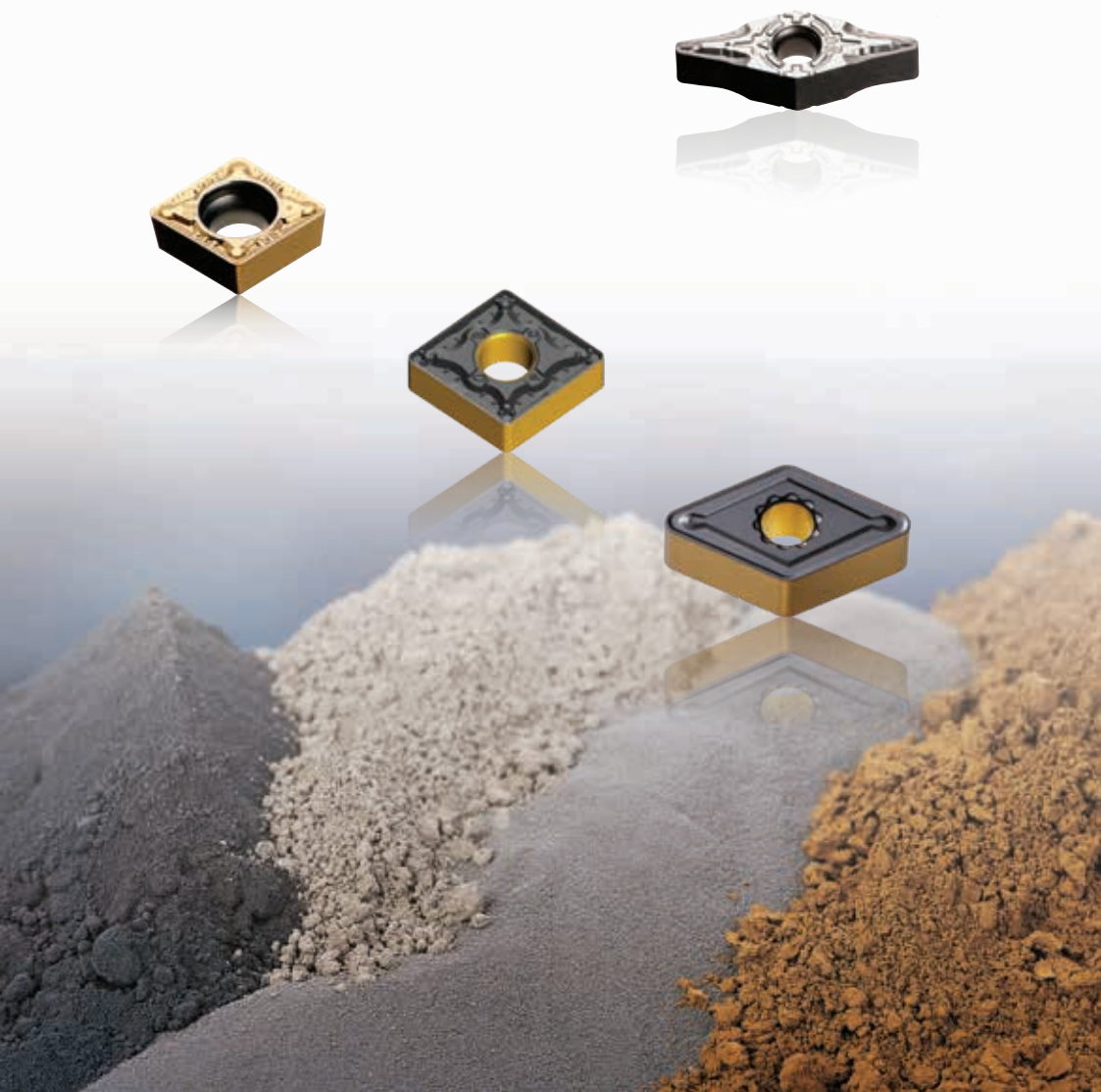

Grade Comparison Table

▶ Turning grades

ISO class	TaeguTec	Sandvik	Walter	Seco	Kennametal	MMC	Sumitomo	Tungaloy	Kyocera	Korloy	Iscar
P	TT8105B TT8105	GC4305 GC4205	WKP01G WPP05S WPP05	TP0501 TP0500	KCP05	UE6105 UE6005	AC810P	T9205 T9105 T9005	CA510 CA5505		
	TT8115B TT8115	GC4415 GC4315	WKP10G WEP10C WPP10S WPP10 WPV10	TP1501 TP1500	KCP10 KCP10B	MC6115 MC6015 UE6110	AC8015P AC820 AC1000	T9215 T9115 T9015	VP5115 CA515 CA5515 PR1705	NC3215 NC3010	IC807 IC8150 IC9150
	TT8125B TT8125 TT5100 TT9080	GC4425 GC4325	WNN10 WPP20G WPP20S WMP20S WPV20	TP2501 TP2500 TP25	KCU10B KCP25 KCP25B	MC6125 MC6025 UE6020 VP10RT MS7025 VP15TF	AC8025P AC2000 AC1030U ACZ150 AC5005S AC5025S AC520U	T9225 T9125 T9025 AH7025 AH730	CA025P VP5125 CA525 CA5525 PR930 PR1025 PR1725	NC3225 NC3220 NC5330 NC3120 PC5300	IC8250 IC9250
	TT8135B TT8135 TT7100 TT8080 TT8020	GC4335 GC4235 GC2135	WPP30G WPP30S WPP30	TP3501 TP3500	KCP30 KCP30B KCP40	MC6035 UH6400	AC8035P AC830P AC3000	T9235 T9135 T9035	CA530 CA5535 PR1535	NC500H NC5340 NC5350 NC3030 PC5400	IC8350 IC9350 IC830
M	TT9215 TT5080 TT3020	GC2015 GC1115	WNN10 WSM01 WSM10 WSM10S WAM10	TM1501 TM2000 TH1000 TS2000 TS2050 CP200	KCM15B KCM15 KCU10 KCU10B KCS10 KC5510 KC5010	MC7015 US7020 VP10RT MS6015	AC6020M AC610M AC5005S AC5015S AC510U ACZ150 AC520U	T6120 AH110 AH120 AH8005 AH8015	KX409 CA6515 PR930	NC9115 NC9020 PC8105 PC8110	IC6015 IC807 IC804
	TT9225 TT9080	GC2025 GC2220 GC1125	WMP20S WSM20 WSM21	TM2501 TS2500 CP500	KCM25B KCM25 KCU25 KC5525 KC5025	MC7025 US735 MH515 MS7025 MS9025 VP15TF VP20MF VP20RT UP20M	AC6030M AC630M AC5025S AC6040M AC1030U AC530U	T6130 AH630 AH725 AH7025 GH110	CA6525 PR1025 PR1125 PR1225 PR1425 PR1725 PR120S	NC9125 NC5330 NC5340 NC8115 PC5300 PC9030 PC9035	IC6025
	TT9235 TT8080 TT8020	GC2135 GC2035 GC30	WSM30 WAM30	TM3501 TM4000 CP600	KCM35B KCM35	MP7035 UH6400 MP7035	AC6040M	AH6030 T6030 AH645	PR1325 PR1535	NC9135 NC5350 PC5400	IC5400 IC3028 IC830
K	TT7005	GC3205 GC3005	WKK10S WAK10	TK0501 TK1001 TK1000	KCK05	MC5005 UC5105	AC405K	T5105 T5010	CA310 CA4505 CA4010	NC6205 NC6105	IC5005 IC4028
	TT7015	GC3210 GC3015	WKK20S WAK20	TK1501 TK2001 TK2000	KCK15 KCK15B	MC5015 UC5115	AC410K AC415K	T5115 T5020 T515	CA315 CA4515 CA4115	NC6315 NC6210 NC6110	IC5010
	TT7025	GC3215 GC3225	WAK30		KCK20B KCK20	MH515	AC420K	T5125	CA320 CA4120	NC6215	IC8150
S H	TT3005 TT5080 TT3010	GCS05F GC1105 GC1115	WNN10 WSM01	CP200 CP250 TH1000 TH1500 TS2000 TS2050 TS2500	KCU10 KCU10B KCS10 KCS10B KC5510 KC5010	MV9005 US905 MP9005 MP9015 VP05RT VP10RT	AC5005S AC5015S AC510U ACZ1500	AH8005 AH110 AH905 AH8015	PR1305 PR115S	PC8105 PC8110	IC804 IC807 IC806 IC1007 IC907
	TT3020 TT9080 TT8080	GC15 GC1125 GC1135 GC1515 GC1525 S205	WSM10 WSM10S WSM21 WSM20 WSM20S WSM30 WSM30S	TS2500 CP500 CP600	KCU25 KCU30 KC5525 KC5025	MS6015 VP15TF VP20RT MP9025 MS9025 MS7025	AC520U AC5025S AC6040M AC1030U AC530U	AH9030 AH120 AH725 AH7025 SH730 AH7025 AH6030	PR1310 PR005S PR015S PR115S PR120S PR1125 PR1325 PR1535	PC8115 PC5300 PC5400 PC9035	IC808 IC908 IC830

Grade Comparison Table

► Miniature turning grades

ISO class	TaeguTec	ARNO	Diametal	Kyocera	NTK	Tungaloy	Sumitomo	Horn
P	TT4410 TT4430 TT9020	AM5015 AM5025 AM5020 AM5120 AM5120+ AP7220 AP5030 AM5040	D60 D30 D10	PR1705 PR1725 PR1425 PR1005 PR1025 PR1115 PR1225 PR930 PR1535	VM1 DM4 DT4 TM4 ZM3 QM3 CP7	AH710 SH725 SH730 AH725 AH7025 AH730 AH9030 AH120 AH130 AH3135	ACZ150 AC5015S AC5025S AC530U AC1030U	TH35 (TiAlN) Ti25(TiCN) TN35(TiN)
M	TT4410 TT4430 TT9020	AM5110 AN5015 AM5025 AM5020 AM5120 AM5120+ AM5220 AM5130 AP7220 AP5030 AM5040	D60 D30 D20 D10	PR1705 PR1725 PR1425 PR1025 PR1125 PR1225 PR930 PR1535	ST4 VM1 DM4 DT4 TM4 ZM3 QM3	AH710 SH725 AH725 AH120 AH130	ACZ150 AC5015S AC5025S AC530U AC1030U	TH35 (TiAlN) Ti25(TiCN) TN35(TiN)
S	TT4410 TT4430 TT9020	AM5110 AM5015 AM5025 AM5120 AM5120+ AM5220 AM5130 AP7220 AP5030	D60 D30 D20	PR1305 PR1310 PR1325 PR1125 PR1535	DM4 DT4 TM4 QM3 ZM3	AH905 AH8005 AH8015 AH110 SH730 AH725 AH120	ACZ150 AC5015S AC5025S AC530U AC1030U	TH35 (TiAlN) Ti25(TiCN) TN35(TiN)

Grade Comparison Table

▶ Parting & Grooving Grades

ISO class	TaeguTec	Sandvik	Walter	Seco	Kennametal	MMC	Sumitomo	Tunggaloy	Kyocera	Korloy	Iscar
P	TT5100 TT9080 TT9030 TT4430 TT9010 TT7220 TT8020	CT525 GC3115 GC5015 GC4325 GC4225 GC1125 GC1225 GC2135 GC1135 GC1145	WSM13S WKP23S WSM23S WKP33S WSM33G WSM33S WSM43S	CP200 TGP25 TGP35 TGP45 CP30 T25M T350M CP500 CP600	KCP10 KCP10B KCP25 KCP25B KT315 KC9110 KC9125 KC5010 KC5025 KCU10 KCU25 KCM35B	NX2525 NY5015 VP10RT VP20RT RT9010 RT9020	AC8025P AC830P AC8035P AC530U ACZ150 AC510U AC520U AC5025S AC530U AC1030U T2500A	AH8005 GH130 AH725 T9215 TN620 AH725 AH7025 T9225 ACZ150 SH730 GH730 SH730 NS9530 T9530 AH6235 AH710 J740 TX10S UX30	PV7040 PR915 PR1115 PR1215 TN620 TN60 TN90 TC40 CR9025 PR1025 PR1225 PR1625 PR930 PR630 PR660 PR1535	CN20 A30 NC3020 NC3120 NC3225 NC3030 NC5330 NC9025 PC8110 PC3535 PC5300 PC9030 PC3035 PC230	IC20N IC907, IC507 IC1007 IC9015, IC9025, IC9054 IC807(907) IC808(908) IC1008 IC8250 IC250(950) IC5400 IC354, IC328 IC830(928) IC228
M	TT5100 TT3010 TT9080 TT9030 TT4430 TT3020 TT7220 TT8020	H13A GC1005 GC1105 GC5015 GC1125 GC1225 GC2135 GC1135 GC1145	WSM13S WSM23S WSM33G WSM33S WSM43S	CP200 TGP25 TGP35 TGP45 TGS2050 T25M T350M 890 CP500 HX 883 CP600	K313 KCU10 KC5010 KCU25 KC5025 KCM35B	VP10RT VP20RT	AC8035P ACZ150 AC510U AC5015S AC520U AC5025S AC530U AC1030U AC6040M	AH8005 GH130 AH725 SH725 SH7025 AH6235 SH730 GH730 J740 AH710	PV7040 PR915 PR1115 PR1215 TN620 TN60 TN90 TC40 CR9025 PR1025 PR1225 PR930 PR630 PR660 PR1535	NC9025 NC5330 PC8110 PC9030 PC3035 PC5300	IC1007 IC907 IC808(908) IC1008 IC8250 IC5400 IC1028(830, 928) IC354, IC328 IC228
K	K10 TT7505 TT6080 TT9080 TT9030	H13A GC3115 GC4225 GC4425 GC1125 GC1225 GC1025 GC1125 GC1135	WTA33 WKP13S WAK20 WKP23S WAK30 WKP33S WSM33G WSM33S WPP23	TGH1050 TKG1500 CBN200 CP200 890 HX TGP25 TGP35 TGP45 TGS2050 883 CP500 CP600	K313 KCU10 KCP25B KCU25 KC5010 KC5025	MY5015 VP10RT VP20RT	G10E AC510U AC8025P AC5015S AC520U AC5025S AC530U AC1030U AC425K	AH8005 GH130 AH725 AH710 SH730 GH730 AH6235 T515 TH10	A65 A66N PT600M PV7040 PR905 TN60 TC40 KW10 GW15 PR1215	NC5330 PC5300 A30 NC6110 PC9030 PC215K PC6510	IC20 IC1007 IC5010 IC428, IC418 IC807, IC907 IC9015 IC808(908) IC8250 IC250(950) IC228
N	K10 TT9080 TT9030	H13A GC1005 GC1105 GC1115 GC1025 GC1225	WK1	890 883 HX	K313 KCU10 KC5010 KC5025 KCU25 KCM35B	RT9010 RT9020	ACZ150 G10E AC530U	TH10 KC05F KS05F TH10 SH725 SH730	KPD001 KPD010 KW10 GW15 PDL025	G10E H01 A30 PC215K	ID5 IC20 IC08 IC228 IC28
S	K10 TT3010 TT9080 TT9030 TT4430 TT3020 TT8020	GC1005 GC1105 S205 GC1115 GC1025 GC1225 GC1145	WSM13S WSM23S WSM33G WSM33S WSM43S	TGH1050 890 CP200 TGS2050 HX CP500 883 CP600 CBN010 CBN170 CBN170C	K313 KCU10 KC5010 KCU25 KC5025	RT9010 MP9015 RT9020 MP9025 VP10RT VP20RT	AC425K G10E AC5015S AC5025S AC1030U	AH8005 AH905 GH130 AH725 AH7025 SH725 SH730 TH10	KPD001 KPD010 KW10 GW15	PC5300 PC3035	IC804 IC806 IC1007 IC807, IC907 IC07 IC20 IC08 IC808(908) IC1008 IC830(928)
H	TT6080	CB7015 CB7115	WAK20	CBN10 TGH1050 T350M TGS2050 HX CBN200 CP200 890 883	KCU10 KC5010 KCU25	BC8110	H10	BXA10 BX360	KBN510 KBN525 A65 A66N PT600M		IB50 IC428 IC1007 IC807, IC907 IC808(908)

Grade Comparison Table

► Cermet grades

ISO class	TaeguTec	Sandvik	Kennametal	Sumitomo	Kyocera	Tungaloy	Mitsubishi	Korloy	Seco	NTK	Ceramtec
P01	"PV3010 PV3030"		KT315	T110A T1000A T1500Z	PV720 PV710 PV7040 CCX	NS520	AP25N NX1010 NX2525	CC1500		T3N	SC35
P10	CT3000	CT5005 CT5015 CT525 GC1525	KT5020 KT125 KT150	T1500A T1200A T2000Z	TN60 TN610 TN620 TN6020 TC40N	AT9530 GT9530 J9530	MP3025 UP35N	CC2500 CN1500 CN2000	TP1030 CMP CM	T15 C30 Q50	SC15 SC8015 SC7035 SC40
M01	PV3010 PV3030		KT315		PV30 TN30 PV7010	NS520	AP25N NX2525	CC1500		T3N	SC35
M10	CT3000	CT5005 CT5015 CT525 GC1525	KT5020 KT125 KT150	T1500A	PV7020 PV60 TN6010 TN6020 TN60	AT9530 GT9530 J9530	MP3025 UP35N	CC2500 CN1500 CN2000	TP1030 CMP CM	T15 C30 Q50	SC15 SC8015 SC7035 SC40
K01	PV3030		KT315	T1000A	PV30 PV7005 PV7020 PV60	NS520	AP25 NX2525	CN1500	CM	T3N Q15	SC8015
K10	CT3000	CT5015	KT125		TN60 TN6020	AT9530 GT9530 J9530 NS9530		CN2500	C15M	T15 Z15 C7Z	SC7015

Grade Comparison Table

► Ceramic grades

ISO class	Composition	TaeguTec	Sandvik	Kennametal	Ceramtec	NTK	Kyocera	Sumitomo	Tungaloy
K	Al ₂ O ₃ , ZrO ₂	AW120	CC620		SN60 SN80	HC1 HW2	KA30		TZ120
	Al ₂ O ₃ , TiC	AB30	CC650	KY1615	SH2 SH4	HC2 HC5 HC6	A65	NB90S NB90M	LX21
	Si ₃ N ₄ , Al ₂ O ₃ , Y ₂ O ₃ , AlN	AS500		KY1310 KY3000	SL506 SL508 SL606 SL608	SX9			
	S ₃ N ₄ , ZrO ₂ , Al ₂ O ₃ , Y ₂ O ₃	AS10	CC6090 CC6190	KY1320 KY3500 KYK10	SL500 SL808	SX1 SX6 SX8	KS6000 KS6050	SN2000K SN2100K NS260	FX105 CX710
	CVD coated	SC10	CC1690	KY3400 KYK25	SL550C SL554C SL654C SL658C SL854C SL858C	SP2 SP9	CS7050	NS260C	CXC73
H	Al ₂ O ₃ , TiCN	AB20	CC6050		SH2 SH4	HC2 HC5 HC7			LX10
	PVD coated	AB2010	CC670	KY4400		ZC4 ZC7	A66N PT600M	NB100C	LX11
S	Al ₂ O ₃ , SiC whisker	TC430	CC6060 CC6065 CC6160	KY4300		WA1 WA5		WX2000	
	Si ₃ N ₄ , TiN	TC3020 TC3030	CC6220 CC6230	KY2100 KY1540 KYS30 KYS25 KYS30P		SX3 SX5 SX7 SX9	KS6030 KS6040	SN1000S SN2000S	TS200 TS300

Grade Comparison Table

► CBN grades

ISO class	TaeguTec	Iscar	Tungaloy	Sumitomo	Sandvik	Kennametal	Mitsubishi	Kyocera	Seco
H	TB610	IB10H IB50	BX310	BN1000 BNX10	CB7105 CB7015	KB1610	MBC010	KBN510	CBN010
		IB10HC	BXC30 BXA30	BNC80 BNC100 BNC2010		KB5610 KB9610	MB8025 BC8105 BC8210	KBN10M KBN10C KBN25C	CBN050C CH0550
	TB2015 TB650	IB20H IB55	BX330 BX530	BN250 BN2000 BNX20	CB7115 CB7025	KB1625	MB810	KBN525	CBN100
		IB25HA	BXM10 BXC30 BXA40	BNC160 BNC2020		KB5625	MB820 BC8110 BC8220	KBN05M KBN25M	CBN160C CH2540
	TB670	IB25HC	BX360 BX380	BNX25 BN350	CB7125 CB7135 CB50 CB7525 CB7925		MB825 MB8025 BC8120 BC8220		CBN150 CBN170
			BXM20 BXA20 BXA40 BXC50	BNC200 BNC300			MB835 BC8020 BC8130		KBN30M
K	TB7015 TB730	IB90	BX930 BX850 BX950	BN500 BN7500 BN7000	CB50 CB7525	KB1630 KB1345	MB4020 MB710	KBN475 KBN60M KBN65B	CBN200
		IB05S IB10S	BX470 BX480	BN700 BNC500	CB7050	KB5630 KB9640	MB730	KBN65M KBN70M KBN570	CH3515
	KB90A TB7020		BX90S BXC90	BNS800	CB7925		MBS140	KBN900	CBN200 CBN300 CBN300P CBN350 CBN400C

Grade Comparison Table

► PCD grades

ISO class	TaeguTec	Iscar	Tungaloy	Sumitomo	Sandvik	Kennametal	Mitsubishi	Kyocera	Seco	NTK
N01-N10	TC1010	ID8	DX180 DX160	DA90		KD1405	MD203	KPD230	PCD30M PCD30	
N05-N20	TC1020	ID5	DX140	DA150	CD10	KD1400	MD220	KPD010	PCD20	PD1
N15-N30	TC1030		DX120 DX110	DA2200 DA1000		KD1425	MD205	KPD001	PCD10 PCD05	PD2

SFEED-RUSH Grades

► Turning SFEED-RUSH grades

SFEED-RUSH grades have upgraded toughness and chipping resistance through special post-coating treatment process of CVD grades. Through the post-coating treatment process, single color inserts have been transformed into two different colors, on the side and the top (see the illustrations below).

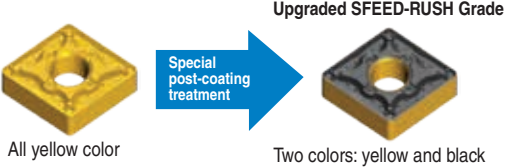
ISO class	Grade	ISO Range	Insert color
P	TT8105B	P05-P15	 <p>All yellow color</p> <p>Special post-coating treatment</p> <p>Upgraded SFEED-RUSH Grade</p> <p>Two colors: yellow and black</p>
	TT8115B	P05-P20	
	TT8125B	P15-P30	
	TT8135B	P25-P40	

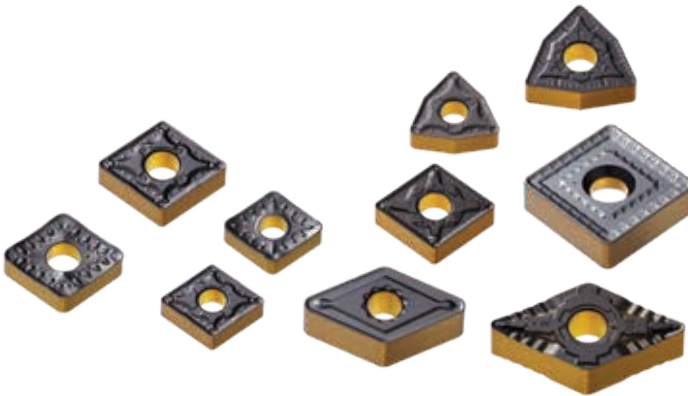

Turning Chip Breaker Comparison Table

► Negative insert

ISO classification		Cutting mode	TaeguTec	Sandvik	Kennametal	Seco	
P	Double sided	Finishing with wiper	WS, WA	WF	FW	W-MF2	
		Medium with wiper	WT	WMX, WM	MW, RW	W-M3, W-M6, W-MF5	
		Finishing	FLP, FA, FS, GG-FU FX			FF, FS	FF1, FF2
			FLP, FG FM	QF	MP-K, LF, FN	MF2	
		Semi-finishing	MLP, FC, FT	PF, XF			
		Medium	VF, DNUX	K		UX	
			MLP, MC		MN	MR3	
			MGP, PC MM	PM, XM QM	P	MF3 MF5, M3	
			MGP, MT	HM, XMR	MP RP, RM		
	Roughing	RGP, RT	PR	RN	M5 MR7, M6		
	Low carbon steel	FLP, FS, GG-FU MLP, FC	WL, LC				
	Single sided	Heavy	RX	PR	RM		
			RH	QR MR	MR, RP	R6, RR9 R4, R5, 37 RR6	
HT, HD HY, HZ			HR, 31	RH	R8, 56, 57 R7		
M	Double sided	Finishing	EA, SF	MF	FP	MF1	
		Medium	EM, ML	MM	MP, UP, MR	MF4	
		Roughing	ET	MR MM-MR	RP	MR6, MF5 MM-RR6	
K	Double sided	Finishing-medium	MT	KF KM	FN	MF5 M4	
		Medium	MG-		MG-, RN	M5	
		Roughing	KT RT	KR	UN	MR7	
N	Double sided	Medium	ML	QM, 23	MS, MP		
S	Double sided	Finishing	EA, SF	SF	GG-FS	MF1	
		Medium	GG-ML MGS, MP, MK	SGF, GP- QM, SM, 23	MS, GP-K UP, P	M1 MF4, MF5	
		Roughing	ET	SR, SMR	RP	M5, MR3, MR4	

Walter	Mitsubishi	Sumitomo	Kyocera	Tungaloy	Korloy	Iscar
FW5, NF	SW	LU-W, SE-W	WP	FW, AFW	VW	WF
MW5, NM	MW	GU-W	WQ, WE	SW, ASW	LW	WG
FP5	FH, FP	FA	DP, GP, PP	TF, 01, CB	VL	SF
FV5	FS, FY	FL	VF	ZF		
NF3, NF4	LP SH	SP, SU, FE		NS, 11 TS, AS, TSF, TQ	VF VQ	NF, F3P
NS6	SA	LU SE, SX	HQ CQ, PQ CJ	SS, NM ZM	VB, VC, LP, CP	
MV5	ES	GX, HM		S		
MP3			GS			
MP5	MP, MV	GU	PG	PM	MP, VM	M3P
MM5, NM4	MA	UG	PS	TM, AM		TF
MU5, NM6 NM9	MH	UX, GE	HS CS		HM, GM	GN
MG-	MG-	UZ	MG- C	33, 37, 38 DM, MG-	B25	MG-
NR4, RP5 RP7	RP GH	ME MU, MX	PT, GT PH, HT	TH	GR	NR, R3P
	FS, FY SY	FL	XF, XP, XP-T XQ, XS	17	VL	
NRF			PX			
NR6	HZ	MP HG HP	HX	THS TRS 57	GH	R3P NM
NRR	HCS HX, HBS, HL	HF HU		65 TU	VT	
	HV, HDS, HXD, HM	HW			VH	T3P
FM5, NF4	FS, LM	SU	MQ, GU	SF	MP, VM	SF, F3M
MM5, NM4	MS, GM, MA	EX, UP, GU	MS, MU, SK	SS, S	MM	TF, VL, M3M
RM5, NR4 NRS	RM	MU, HM	HU	SM, SH	RM	NR, R3M
NM, MK5	LK MA, MK	UZ	KQ MG-	CF CM	MP	M3P, GN
NM5, RK5	MG-, GK		KG, C	MG-		MG-
MV7, RK7	GH, RK	GZ	KH ZS, GC	CH	B25, MK, VR RK, -MA	
MN3	MJ	UP, GX, AG	A3, AH	P, 28	HA	PP
NF4	FJ, LS	EF	MQ	HRF	VP1	SF, F3S
NFT	MJ	SU, UP	TK		VP2	PP
NMS, MS3, NMT	MA, MS	EG, EX	MS, MU, SQ	HRM, HMM, SDM	VP3	TF, VL
RM5, NRS, NRT	GJ, RS	MU			VP4	MR

Turning Chip Breaker Comparison Table

► Positive insert

ISO classification	Cutting mode	TaeguTec	Sandvik	Kennametal	Seco
P	Medium with wiper	WT	WM	MW	W-F2, W-M3
	Finishing	FA FX	PF, UF	UF, 11, GM	FF1
		GT-SL GT-SA, GT-SM			
		FG	UM XF	FP LF	F1
	Medium	PC, GT-SH FM	PM	MP	
		GT-SH MT	XM PR, UR XR	MF	F2, MF2, M5
		PMR-	PMR-	PMR-	
N	Finishing - Medium - G Tol.	GT-SA, FL	AL	HP	AL
S	Finishing - G Tol.	GT-FGS, SA	GT-UM	GT-HP, LF	GT-F1
	Finishing	FG	MF, UM	FP, LF	F1, F2
	Medium	PC	MM		MF2

Walter	Mitsubishi	Sumitomo	Kyocera	Tungaloy	Korloy	Iscar
MW4, PM	MW					WG
PF4, FP4	FV FP	LU FB, FP	XP GK, GP, DP VF	01, PSF	VL, FP	F3P PF
FV4	SMG	FC	CF GF CK	JS	FS VP1	
PS5	LP, SV SQ, SV	FK LB, SU SC, SK	XQ GK		VF HMP	SM 16, GT-
MP4, FP6, MV4		GU UG	GQ HQ	PSS PS	MP	
PM5 MP6, E47, MT-	MQ, MV MT- G	SF, MU	MT-	PM	C25	14, 17 19, M3P
PMR-	PMR-	UJ	G, PMR-	23		
FN2, MN2, GW-FS-1	AZ	AW, AG, AY	AH	AL	AK, AM, AR	AF, AS
GT-FM2, FM4, FM6, PF2	GT-FJ, LS, FS	GT-SI			GT-VP1, MS	
MM4, PF4, PS5	FM, LM, SV	SU	MQ	PSF	VL	PF, F3M
RM4, PM5	MM, MV	MU		PSS, PS, PM	MP	

Hardness Conversion Table

Vickers 50kg HV	Brinell HB10mm ball LOAD 3000kgf		Rockwell				Shore's HS	Tensile strength N/mm ² (kgf/mm ²)
	Standard ball	Tungsten carbide ball	A scale 60kgf diamond brale HRA	B scale 100kgf 1/16in ball HRB	C scale 150kgf diamond brale HRC	D scale 100kgf diamond brale HRD		
1900			93.1		80.5			
1800			92.6		79.2			
1700			91.9		77.9			
1600			91.3		76.6			
1500			90.5		75.3			
1450			90.1		74.6			
1400			89.6		74.0			
1350			89.1		73.4			
1300			88.7		72.7			
1250			88.3		72.1			
1200			87.9		71.5			
1150			87.5		70.9			
1100			87.1		70.3			
1050			86.6		69.6			
1000			86.2		68.9			
940			85.6		68.0	76.9	97	
920			85.3		67.5	76.5	96	
900			85.0		67.0	76.1	95	
880		(767)	84.7		66.4	75.7	93	
860		(757)	84.4		65.9	75.3	92	
840		(745)	84.1		65.3	74.8	91	
820		(733)	83.8		64.7	74.3	90	
800		(722)	83.4		64.0	74.8	88	
780		(710)	83.0		63.3	73.3	87	
760		(698)	82.6		62.5	72.6	86	
740		(684)	82.2		61.8	72.1	84	
720		(670)	81.8		61.0	71.5	83	
700		(656)	81.3		60.1	70.8	81	
690		(647)	81.1		59.7	70.5		
680		(638)	80.8		59.2	70.1	80	
670		630	80.6		58.8	69.8		
660		620	80.3		58.3	69.4	79	
650		611	80.0		57.8	69.0		
640		601	79.8		57.3	68.7	77	2205(210)
630		591	79.5		56.8	68.3		2020(206)
620		582	79.2		56.3	67.9	75	1985(202)
610		573	78.9		55.7	67.5		1950(199)
600		564	78.6		55.2	67.0	74	1905(194)
590		554	78.4		54.7	66.7		1860(190)
580		515	78.0		54.1	66.2	72	1825(186)
570		535	77.8		53.6	65.8		1795(183)
560		525	77.4		53.0	65.4	71	1750(179)
550	(505)	517	77.0		52.3	64.8		1750(174)
540	(496)	507	76.7		51.7	64.4	69	1660(169)
530	(488)	497	76.4		51.1	64.0		1620(165)
520	(480)	488	76.1		50.5	63.5	67	1570(160)
510	(473)	479	75.7		49.8	62.9		1530(156)
500	(465)	471	75.3		49.1	62.2	66	1459(153)
490	(456)	460	74.9		48.4	61.6		1460(149)
480	488	452	74.5		47.7	61.3	64	1410(144)





► Note: Gray figures come from ASTM E 140 table (Calculated by SAE-ASM-ASTM together)







Vickers 50kg HV	Brinell HB10mm ball LOAD 3000kgf		Rockwell				Shore's HS	Tensile strength N/mm ² (kgf/mm ²)
	Standard ball	Tungsten carbide ball	A scale 60kgf diamond brale HRA	B scale 100kgf 1/16in ball HRB	C scale 150kgf diamond brale HRC	D scale 100kgf diamond brale HRD		
470	441	442	74.1		46.9	60.7		1570(160)
460	433	433	73.6		46.1	60.1	62	1530(156)
450	425	425	73.3		45.3	59.4		1459(153)
440	415	415	72.8		44.5	58.8	59	1460(149)
430	405	405	72.3		43.6	58.2		1410(144)
420	397	397	71.8		42.7	57.5	57	1370(140)
410	388	388	71.4		41.8	56.8		1330(136)
400	379	379	70.8		40.8	56.0	55	1290(131)
390	369	369	70.3		39.8	55.2		1240(127)
380	360	360	69.8	(110.0)	38.8	54.4	52	1250(123)
370	350	350	69.2		37.7	53.6		1170(120)
360	341	341	68.7	(109.0)	36.6	52.8	50	1130(115)
350	331	331	68.1		35.5	51.9		1095(112)
340	322	322	67.6	(108.0)	34.4	51.1	47	1070(109)
330	313	313	67.0		33.3	50.2		1035(105)
320	303	303	66.4	(107.0)	32.2	49.4	45	1005(103)
310	294	294	65.8		31.0	48.4		980(100)
300	284	284	65.2	(105.5)	29.8	47.5	42	950(97)
295	280	280	64.8		29.2	47.1		935(96)
290	275	275	64.5	(104.5)	28.5	46.5	41	915(94)
285	270	270	64.2		27.8	46.0		905(92)
280	265	265	63.8	(103.5)	27.1	45.3	40	890(91)
275	261	261	63.5		26.4	44.9		875(89)
270	256	256	63.1	(102.0)	25.6	44.3	38	855(87)
265	252	252	62.7		24.8	43.7		840(86)
260	247	247	62.4	(101.0)	24.0	43.1	37	825(84)
255	243	243	62.0		23.1	42.2		805(82)
250	238	238	61.6	99.5	22.2	41.7	36	795(81)
245	233	233	61.2		21.3	41.1		780(79)
240	228	228	60.7	98.1	20.3	40.3	34	765(78)
230	219	219		96.7	(18.0)		33	730(75)
220	209	209		95.0	(15.7)		32	695(71)
210	200	200		93.4	(13.4)		30	670(68)
200	190	190		91.5	(11.0)		29	635(65)
190	181	181		89.5	(8.5)		28	605(62)
180	171	171		87.1	(6.0)		26	580(59)
170	162	162		85.0	(3.0)		25	545(56)
160	152	152		81.7	(0.0)		24	515(53)
150	143	143		78.7			22	490(50)
140	133	133		75.0			21	455(45)
130	124	124		71.2			20	425(44)
127	121			69.8			19	(42)
122	116			67.6			18	(41)
117	111			65.7			15	(39)

▶ Note: Gray figures come from ASTM E 140 table (Calculated by SAE-ASM-ASTM together)

Material Conversion Table





► According to VDI 3323 standard







Material group					
	AISI/SAE	Material No. DIN	BS	EN	AFNOR
1	A 366 (1012) 1008	0.0030 C10	040 A 10 045 M 10 1449 10 CS		AF 34 C 10 XC 10
1		1.0028 Ust 34-2 (S250G1T)			A 34-2
1		1.0034 RSt 34-2 (S250G2T)	1449 34/20 HR, HS, CR, CS		A 34-2 NE
1		1.0035 St185 (Fe 310-0) St 33	Fe 310-0 1449 15 HR, HS		A 33
1	A 570 Gr. 33,36	1.0036 S235JRG1 (Fe 360 B) Ust 37-2	Fe 360 B 4360-40 B		
1		1.0037 S235JR (Fe 360 B) St 37-2	Fe 360 B 4360-40 B		E 24-2
1	1115	1.0038 GS-CK16	030A04	1A	
1	A 570 Gr. 40	1.0044 S275JR (Fe 430 B) St44-2	Fe 430 B FN 1449 43/25 HR, HS 4360-43 B		E 28-2
1		1.0045 S355JR	4360-50 B		E 36-2
1	A 570 Gr.50 A 572 Gr.50	1.0050 E295 (Fe 490-2) St 50-2	Fe 490-2 FN 4360-50 B		A 50-2
1	A 572 Gr. 65	1.0060 E335 (Fe 590-2) St 60-2	Fe 60-2 4360-55 E; 55 C		A 60-2
1		1.0060 St 60-2			
1		1.0070 E360 (Fe 690-2) St 70-2	Fe 690-2 FN		A 70-2
1		1.0112 P235S	1501-164-360B LT20		A37AP
1		1.0114 S235JU;St 37-3 U	4360-40C		E 24-3
1	A 284 Gr.D A 573 Gr.58 A 570 Gr 36;C A 611 Gr. C	1.0116 S235J2G3 (Fe 360 D 1) St 37-3	Fe 360 D1 FF 1449 37/23 CR 4360-40 D		E 24-3 E 24-4
1		1.0130 P265S	1501-164-400B LT 20		A 42 AP
1		1.0143 S275J0; St 44-3 U	4360-43C		E 28-3

					
SS	UNI	UNE	JIS	KS	GOST
	C 10 1 C 10	F.1511 F.151A	S 10C	SM 10C	10
	Fe 330, Fe 330 B FU		SS 330	SS 330	
	Fe 330 B FU				St2sp
1300	Fe 320	Fe 310-0			St0
1311	FE37BFU	AE 235 B			16D, 18Kp
1312		Fe 360 B			St3Kp
1311	Fe 360 B 1449 37/23 HR	AE 235 B Fe 360 B	STKM 12A;C	STKM 12A;C	
1325	Fe 330, Fe 330 B FU		SS 330	SS 330	
1412	Fe 430 B Fe 430 B FN	AE 275 B Fe 430 B FN	SM 400 A;B;C	SM 400 A;B;C	St4ps; sp
2172	Fe 510 B	AE 355 B			
1550	Fe 490	a 490-2	SS 490	SS 490	ST5ps; sp
2172		Fe 490-2 FN			
1650	Fe 60-2 Fe 590	A 590-2 Fe 590-2 FN	SM 570	SM 570	St6ps; sp
	Fe 60-2				
1655	Fe 70-2 Fe 690	A 690-2 Fe 690-2 FN			
	Fe 360 C	AE 235 C			
	Fe 360 C	AE 235 C			
1312	Fe 360 D1 FF				
1313	Fe 360 C FN Fe 360 D FF Fe 37-2	AE 235 D Fe 360 D1 FF			St3kp; ps; sp 16D
		SPH 265			
1414-01	Fe 430 D	AE 275 D			

Material Conversion Table





► According to VDI 3323 standard







Material group					
	AISI/SAE	Material No. DIN	BS	EN	AFNOR
1	A 573 Gr. 70	1.0144 S275J2G3 (Fe 430 D 1)	Fe 430 D1 FF		E 28-3
	A 611 Gr.D	St 44-3	4360-43 C; 43 D		E 28-4
1		1.0149 S275JOH; RoSt 44-2	4360-43C		
1		1.0226 DX51D; St 02 Z	Z2		GC
1	M 1010	1.0301 C10	040 A 10		AF 34 C 10
			045 M 10		XC 10
			1449 10 CS		
1	A 621 (1008)	1.0330 DC 01 St 2; St 12	1449 4 CR		TE
			1449 3 CS		
1	A 619 (1008)	1.0333 Ust 3 (DC03G1) Ust 13	1449 2 CR;3 CR		E
1	A 621 (1008)	1.0334 UStW 23 (DD12G1)			SC
1	A 622 (1008)	1.0335 DD13; StW 24	1449 1 HR		3C
1	A 620 (1008)	1.0338 DC04 St4; St 14	1449 1 CR;2 CR		ES
			1.0345 P235GH HI	1501 Gr. 141-360	A 37 CP;AP
				1501 Gr. 161-360; 151-360	
				1501 Gr. 161-400; 154-360	
				1501 Gr. 164-360; 161-360	
1	(M) 1020 M 1023	1.0402 C22	055 M 15, 070 M 20 2C/2D		AF 42 C 20;
			1499 22 HS, CS		XC 25;1 C 22
1	1020	1.0402 C22	050A20	2C/2D	CC20
1	1020;1023	1.0402 C22	055 M 15, 070 M 20 2C		AF 42 C 20;
					XC 25;1 C 22
1		1.0425 P265GH H II	1501 Gr. 161-400;151-400 1501 Gr. 164-360; 161-400 1501 Gr. 164-400;154-400		A 42 CP; AP
1	A27 65-35	1.0443 GS-45	A1		E 23-45 M
1		1.0539 S355NH;StE 335			TSE 355-4
1		1.0545 S355N; StE 355	4360-50E		E 355 R
1		1.0546 S355NL;TStE 355	4360-50EE		E 355 FP
1		1.0547 S355JOH	4360-50C		TSE 355-3
1		1.0549 S355 NLH;TStE 355			
1		1.0553 S355JO;St 52-3U	4360-50C		E 36-3

					
SS	UNI	UNE	JIS	KS	GOST
1411, 1412 1414	Fe 430 B, Fe 430 C (FN) Fe 430 D (FF)	AE 275 D Fe 430 D1 FF	SM 400 A;B;C	SM 400 A;B;C	St4kp> ps; sp
1412-04	Fe 430 C	Fe 430 C			
1151 10	FeP 02 G C 10 1 C 10	FeP 02 G F.1511 F.151.A	S 10C	SM 10C	10
1142	FeP 00 FeP 01 FeP 02	AP 11 AP 02	SPHD SPCD	SPHD SPCD	15kp
	FeP 12 FeP 13	AP 12 AP 13	SPHE SPHE	SPHE SPHE	10kp 08kp
1147	FeP 04	AP 04	SPCE	SPCE	08jU; JUA
1331 1330	FeE235, Fe 360 1 KW;KG Fe 360 2 KW;KG	A 37 RC I RA II	SGV 410, SGV 450, SGV 48, SPV 450;SPV 480	SGV 410, SGV 450, SGV 480, SPPV 450;SPPV 480	
1450	C 20 C 21, C 25	1 C 22 F.112	S20C	SM 20C	20
1450	C20, C21	F.112	S22C	SM 22C	20
1450	C 20; C 21;C 25	1 C 22F.112	S 20 C;S 22 C	SM 20 C;SM 22C	
1431 1430 1432 1305	Fe 410 1 KW; KG; KT Fe 410 2 KW; KG	A 42 RC I A 42 RC II	SPV 315; SPV 355 SG 295; SGV 410 SGV 450; SGV 480	SPPV 315; SPPV 355 SG 295; SGV 410 SGV 450; SGV 480	16K 20K
2134-04	Fe 510 B	Fe 355 KGN			
2334-01	FeE 355 KG	AE 355 KG			
2135-01	FeE 355 KT	AE 355 KT			
2172-04	Fe 510 C	Fe 510 C			
2135	Fe 510 D Fe 510 C	FeE 355 KTM			

Material Conversion Table





► According to VDI 3323 standard







Material group				
	AISI/SAE	Material No. DIN	BS EN	AFNOR
1	A 633 Gr.C A 588	1.0562 P355N StE 355	1501 Gr.225-490A LT 20	FeE 355 KG N E 355 R/FP; A 510 AP
1		1.0565 P355NH; WStE 355	1501-225-490B LT 20	A 510 AP
1		1.0566 P355NL1; TStE 355	1501-225-490A LT 50	A 510 FP
1	1	1.0570 S355J2G3 St 52-3	Fe 510 D1 FF 1449 50/35 HR>HS 4360-50 D	E 36-3 E 36-4
1	1213	1.0715 9 SMn 28 (1SMn30)	230 M 07	S 250
1	1213	1.0715 9 SMn 28	230 M 07	S 250
1	12 L 13	1.0718 9 SMnPb 28 (11SMnPb30)		S 250 Pb
1	1108 1109	1.0721 10 S 20	(210 M 15)	10S20 10F 2
1	11 L 08	1.0722 10 SPb 20		10PbF 2
1	11 L 08	1.0722 10 SPb 20		10PbF 2
1	1215	1.0736 9 SMn 36 11SMn37)		S 300
1	12 L 14	1.0737 9 SMnPb 36 (11SMnPb37)		
1		1.0972 S315MC; QStE 300 TM	1501-40F30	E 315 D
1		1.0976 S355MC; QStE 360 TM	1501-43F35	E 355 D
1		1.0982 S460MC; QStE 460 TM	1501-50F45	
1		1.0984 S500MC; QStE 500 TM		E 490 D
1		1.0986 S500MC; QStE 500 TM	1501 - 60F55	E 560 D
1	1010	1.1121 CK 10 (C10E)	040 A 10	XC 10
1		1.1121 St 37-1	4360 40 A	
1	1015	1.1141 CK 15 (C15E)	040 A 15 080 M 15	32C XC 12 XC 15 XC 18
1	1020 1023	1.1151 C22E CK 22	055 M 15 (070 M 20)	2 C 22 XC 18 XC 25
1	D 3	1.2080 X 210 Cr 12	BD 3	Z 200 C 12

					
SS	UNI	UNE	JIS	KS	GOST
2106	FeE 355 KG;KW	AEE 355 KG;DD	SM 490 A;B;C; YA;YB	SM 490 A;B;C; YA;YB	15GF
2106	FeE 355-2				
2107-01	FeE 355-3				
2132, 2133	17GS	AE 355 D	SM 490 A;B;C;	SM 490 A;B;C;	17GS
2134,	17G1S	Fe 510, D1 FF	YA;YB	YA;YB	17G1S
2174					
1912	CF SMn 28	F.2111 - 11 SMn 28	SUM 22	SUM 22	
1912	CF 9 SMn 28	11 SMn 28	SUM 22	SUM 22	
1914	CF 9 SMnPb 28	F.2112-11 SMnPb 28	SUM 22 L SUM 23 L, SUM 24 L	SUM 22 L SUM 23 L, SUM 24 L	
	CF 10 S 20	F. 2121 - 10 S 20			
	CF 10 SPb 20	F.2122-10 SPb 20			
	CF 10 SPb 20	10 SPb 20			
	CF 9 Mn 36	F.2113 - 12 SMn 35	SUM25	SUM25	
2642	FeE 355TM				
2662	FeE 490 TM				
	FeE 560 TM				
1265	C 10, 2 C 10 2 C 15	F-1510-C 10 K	S 9 CK S 10 C	S 9 CK S 10 C	08;10
1300					
1370	C 15	C 16 F.1110-C 15 F.1511-C 16 K	S 15 S 15 CK	SM 15C SM 15CK	15
1450	C 20	C 25 F.1120-C 25 K	S 20 C, S 20 CK S 22 C	SM 20 C, SM20 CK SM22 C	20
2642					

Material Conversion Table





► According to VDI 3323 standard







Material group					
	AISI/SAE	Material No. DIN	BS	EN	AFNOR
1	A36	St 44-2	4360 43 A		NFA 35-501 E 28
1		StE 320-3Z	1 501 160		
1	A572-60	1.8900 StE 380	4360 55 E		
2	(M) 1025	1.0406 C 25	070 M 26		1 C 25
2		1.0416 GS-38			20-400 M
2	A 537 Cl.1 A 414 Gr. G A 612	1.0473 P355GH	19 Mn 6		A 52 CP
2	1035	1.0501 C 35	080 A 32, 080 A 35 080 M 36, 1449 40 CS		1 C 35 AF 55 C 35 XC 38
2	1045	1.0503 CF 45 (C45G)	060 A 47 080 M 46		XC 42 H 1 TS
2	1040	1.0511 C 40	080 M 40		1 C 40 AF 60 C 40
2		1.0540 C 50			
2	A27 70-36	1.0551 GS-52	A2		280-480 M
2	A148 80-40	1.0553 GS-60	A3		320-560 M
2	A738	1.0577 S355J2G4 (Fe 510 D 2)	Fe 510 D2 FF 1501 Gr.224-460 1501 Gr. 224-490		A 52 FP
2	1140	1.0726 35 S 20	212 M 36	8M	35MF 6
2	1146	1.0727 45 S 20 (46S20)			45 MF 4
2	1035 1041	1.1157 40Mn4	150 M 36	15	35 M 5 40 M 5
2	1025	1.1158 C25E CK 25	(070 M 25)		2 C 25 XC 25
2	1536	1.1166 34Mn5			
2	1330	1.1170 28Mn6	(150 M 28), (150 M 18)		20 M 5, 28 Mn 6
2	1330	1.1170 28Mn6	150 M 5		20 M 5
2	1330	1.1170 28Mn6		14A	20 M 5
2		1.1178 C30E; CK 30	080M30		XC 32

					
SS	UNI	UNE	JIS	KS	GOST
1411					
1421					
2145	FeE390KG		S 25C	SM 25C	
	C 25 1 C 25				
1306					
2101	Fe E 355-2	A 52 RC I RA II	SGV 410	SGV 410	
2102			SGV 450	SGV 450	
			SGV 480	SGV 480	
1572	C 35	F.113	S35C	SM35C	35
1550	1 C 35				
1672	C 43		S 45 C	SM 45 C	45
	C 46				
	C 40	1 C 40	S 40 C	SM 40 C	
1674	C 50	1 C 50			
1505					
1606					
2107		A 52 RB II AE 355 D			
1957		F.210.G			
1973			S 09CK	SMn 433	
C 25	F.1120 - C 25 K	S 25 C S 28 C	S 25 C	SM 25 C	
	TO.B	SMn 433 H			
1421	C 28 Mn	28 Mn 6	SCMn 1	SCMn 1	30G
2145					
	C 28 Mn		SCMn 1	SCMn 1	
	C 30	2 C 30			

Material Conversion Table





► According to VDI 3323 standard







Material group					
	AISI/SAE	Material No. DIN	BS	EN	AFNOR
2	1035	1.1180 C35R Cm 35	080 A 35		3 C 35 XC 32
2	1035	1.1181 C35E	080 A 35		2 C 35, XC 32
	1038	CK 35	(080 M 36)		XC 38 H 1
2	1035	1.1181 C35E CK 35	080 A 35 (080 M 36)		
2	1042	1.1191 GS- Ck 45	080 A 46		XC 45
2	1049	1.1206 C50E	080 M 50		2 C 50
	1050	CK 50			XC 48 H 1; XC 50 H 1
2	1050	1.1213 Cf 53 (C53G)	070 M 55		XC 48 H TS
	1055				
2	4520	1.5423 22Mo4	1503-245-420		
3		1.0050 St50-2			
3	A 516 Gr.70 A 515 Gr. 70 A 414 Gr.F; G	1.0481 P295GH 17 Mn 4	1501 Gr. 224		a 48 Cp;AP
3	1043	1.0503 C35	060 A 47 080 M 46 1449 50 HS, CS		1 C 45 AF 65 C 45
3	1074	1.0614 C 76 D; D 75-2			XC 75
3	1086	1.0616 C 86 D; D 85-2			XC 80
3	1095	1.0618 C 92 D;D 95-2			XC 90
3	1036 1330	1.1165 30Mn5	120 M 36 (150 M 28)		35 M 5
3	1335	1.1167 30Mn5	150 M 36		40 M 5
3	1040	1.1186 C40E CK 40	060 A 40, 080 A 40 080 M 40		2 C 40 XC 42 H 1
3	1045	1.1191 C45E CK 45	080 M 46 060 A 47		2 C 45 XC 42 H 1 XC 45 XC 48 H 1

 SS	 UNI	 UNE	 JIS	 KS	 GOST
1572		F.1130-C 35 K-1			
1550	C35	F.1130-C 35 K	S 35 C	SM 35 C	35
1572					
1572	C36		S 35 C	SM 35 C	
1660	C45	F-1140			
1674	C 50				50
1674	C 53		S 50 C	SM 50 C	50
	16 Mo 5 KG; KW	F.2602- 16 Mo 5	SB 450 M	SB 450 M	SB 480 M
	FE50				
	Fe 510 KG;KT;KW	A 47 RC I RA II	SG 365, SGV 410	SG 365, SGV 410	14G2
	Fe 510-2 KG;KT;KW		SGV 450	SGV 450	
	FeE 295		SGV 480	SGV 480	
1672	C 45	F.114	S 45 C	SM 45 C	45
1650	1 C 45				
C 85					
		F.8211-30 Mn 5	SMn 433 H	SMn 433 H	27ChGSNMDTL
		f.8311-AM 30 Mn 5	SCMn 2	SCMn 2	30GSL
2120		F. 1203-36 Mn 6	SMn 438 (H)	SMn 438 (H)	35G2
		F. 8212-36 Mn 5	SCMn 3	SCMn 3	35GL
	C 40		S 40 C	SM 40 C	
1672	C 45	F.1140-C 45 K	S 45 C	S 45 C	45
	C 46	F.1142-C48 K	S 48 C	S 48 C	

Material Conversion Table





► According to VDI 3323 standard







Material group					
	AISI/SAE	Material No. DIN	BS	EN	AFNOR
3	1049	1.1201 C45R Cm 45	080 M 46		3 C 45 XC 42 H 1 XC 48 H 1
3		1.7242 18 CrMo 4			
3	A 387 Gr. 12 Cl	1.7337 16 CrMo 4 4			
3	A 387 Gr. 12 Cl	1.7337 16 CrMo 4 4			
3		1.7362 12 CrMo 19 5	3606-625		Z 10 CD 5.05
3	A572-60	17 MnV 6	436055 E		NFA 35-501 E 36
4	1055	1.0535 C55	070 M 55		1 C 55 AF 70 C 55
4	1060	1.0601 C60	060 A 62 1449 HS,CS	43D	1 C 60 AF 70 C 55
4	1070	1.0603 C67	080 A 67 1449 70HS		XC65
4	1074 1075	1.0605 C75	1449 80 HS		
4	1055	1.1203 C55E CK 55	060 A 57 070 M 55		2 C 5 XC 55 H 1
4	1055	1.1209 C55R Cm 55	070 M 55		3 C 55 XC 55 H 1
4	1060 1064	1.1221 C60E CK 60	060 A 62	43D	2 C 60 XC 60 H 1
4	1070	1.1231 CK 67 (C67E)	060 A 67		XC 68
4	1074 1075 1078	1.1248 CK 75 (C75E)	060 A 78		XC 75
4	1086	1.1269 CK 85 (C85E)			XC 90
4	1095	1.1274 Ck 101 (C101E)			XC 100
4	W 112	1.1663 C 125 W			Y2 120
4					
5		1.0070 St70-2			
5		1.7238 49 CrMo 4			
5		1.7701 51 CrMoV 4			

					
SS	UNI	UNE	JIS	KS	GOST
1660	C 45	F.1145-C 45K-1 F.1147C 48 K-1	S 50 C	SM 50 C	
18 CrMo 4	A 18 CrMo 4 5 KW A 18 CrMo 4 5 KW 16 CrMo 20 5				
2142					
1655	C 55 1 C 55		S 55 C	SM 55 C	55
	C 60 1 C 60		S 58 C	SM 58 C	60(G)
	C 67				
	C 75				75
1655	C 55	F.1150-C 55 K	S 55 C	SM 55 C	55
	C 55	F.1155-C 55 K-1			
1655	C 60		S 58 C	SM 58 C	60
1678					60G, 60GA
1770	C 70				65GA 68GA , 70
774	C 75				75(A)
	C 90				85(A)
	C 100	F-5117	SUP 4	SPS 4	
1870					
2223	FE70-2				
	51 CrMoV 4				

Material Conversion Table

► According to VDI 3323 standard







Material group					
	AISI/SAE	Material No. DIN	BS	EN	AFNOR
6	A573-81 65	1.0116 St 37-3	4360 40 B		E 24-U
6	A515 65	1.0345 H1	1 501 161		A 37 CP
6	5120	1.0841 St 52-3	150 M 19		20 MC 5
6	9255	1.0904 55 Si 7	250A53	45	55S7
6	9254	1.0904 55 Si 7	250 A 53		55 S 7
6	9262	1.0961 60SiCr7	1 501 161		60SC6
6	L3	1.2067 100Cr6	BL3		Y100C6
6	L1	1.2108 90 CrSi 5			
6	L2	1.2210 115CrV3			100C3
6		1.2241 51CrV4			
6		1.2311 40 CrMnMo 7			
6	4135	1.2330 35 CrMo 4	708 A 37		34 CD 4
6		1.2419 105WCr6	BO1		105WC13
6	0 1	1.2510 100 MnCrW 4	BS1		8 MO 8
6	S1	1.2542 45 WCrV7			
6	S1	1.255 60WCrV7			55WC20
6	L6	1.2713 55NiCrMoV6			55NCDV7
6	L6	1.2721 50NiCr13			55 NCV 6
6	O2	1.2842 90MnCrV8	BO2		90 MV8
6	E 50100	1.3501 100 Cr 2			55WC20
6	52100	1.3505 100Cr6	2 S 135 535 A 99	31	100 C 6
6		1.5024 46Si7			45 S 7; Y 46 7;46 SI 7
6	9255	1.5025 51Si7			51 S 7 51 Si 7
6	9255	1.5026 55Si7	251 a 58		55 S 7
6	9260	1.5027 60Si7	251 A 60 251 H 60		60 S 7
6	9260 H	1.5028 65Si7			60 S 7
6		1.5120 38 MnSi 4			

					
SS	UNI	UNE	JIS	KS	GOST
1312	Fe37-3				
1330					
2172	Fe 52	F-431			
2085	55Si8	56Si7			
2090		F-431			
60SiCr8	60SiCr8				
	100Cr6				
2092	105WCR 5				
	107CrV3KU				
	35 cRmO 8 KU				
2234	35CrMo4	34CrMo4	SCM435TK	SCM435TK	
2140	10WCr6	105WCr5			
2140	10WCr6	105WCr5	SKS 31	STS 31	
2710	45 WCrV8 KU	45WCrSi8			
2710	58WCr9KU				
		F.520.S	SKT 4	STF 4	
2550		f-528			
2258	100Cr6	F.1310 - 100 Cr 6	SUJ2	STB 2	SchCh 15
		F. 1451 - 46 Si 7			
2090	48 Si 7	F.1450-50 Si 7			
	50 Si 7				
2085 2090	55 Si 7	F.1440 - 56 Si 7			55S2
	60 Si 7	F. 1441 - 60 Si 7			60S2
			50 P 7 SUP 6	SPS 6	

Material Conversion Table

► According to VDI 3323 standard







Material group					
	AISI/SAE	Material No. DIN	BS	EN	AFNOR
6	A 204 Gr.A 4017	1.5415 16Mo3 15 Mo 3	1503-243 B		15 D 3
6	4419	1.5419 20Mo4	1503-243-430		
6	A 350-LF 5	1.5622 14Ni6			16N6
6	3415	1.5732 1 NiCr10			14 NC 11
6	3310; 3314	1.5752 14NiCr14	655M13	36A	12NC15
6		1.6587 17CrNiMo6	820A16		18NCD6
6		1.6657 14NiCrMo134			
6	5515	1.7015 15 Cr 3	523 M 15		12 C 3
6	5132	1.7033 34Cr4	530A32	18B	32C4
6	5140	1.7035 41C r4	530M40	18	42C4
6	5140	1.7045 42Cr41	530 A 40		42 C 4 TS
6	5115	1.7131 16MnCr5	527 M 17		16 MC 5
6		1.7139 16MnCr5			
6	5515	1.7176 55Cr3	527 A 60	48	55 C 3
6	4135; 4137	1.7220 34CrMo4	708 Aa 37		35 CD 4
6	4142	1.7223 41CrMo4			
6	4140	1.7225 42CrMo4	708 M 0		42 CD 4
6		1.7228 55NiCrMoV6G	823M30	33	
6		1.7262 15CrMo5			12 CD 4
6		1.7321 20 mOcR 4			
6	ASTM A182 F-12	1.7335 13CrMo4 4	1501-620Gr27		
6	A 182-F11;12	1.7335 13 CrMo 4 4	1 501 620 Gr. 27		15 CD 4.5
6	ASTM A 182 F.22	1.7380 10CrMo9 10	1501-622gR31; 45		
6	A182 F-22	1.7380 10 CrMo 9 10	1501-622		12 CD 9.10
6		1.7715 14MoV6 3	1503-660-440		
6	A355A	1.8509 41CrAlMo 7	905 M 39	41B	40 CAD 6.12
7	A570.36	1.0038 S235JRG2 (Fe 360 B) RSt 37-2	Fe 360 B FU 1449 27/23 CR 4360-40 B		E 24-2NE
7	3135	1.5710 36NiCr6	640A35		35NC6

					
SS	UNI	UNE	JIS	KS	GOST
2912	16Mo3(KG;KW)	F. 2601 - 16 Mo 3			
-2512	G 20 Mo 5 G 22 Mo5		SCPH 11	SCPH 11	
14 Ni 6 KG;KT	F.2641 - 15 Ni 6				
16NiCr11	15NiCr11	SNC415(H) SNC815(H)			
	14NiCrMo13				
	14NiCrMo131				
			SCr415(H)	SCr415(H)	
	34Cr4(KB)	35Cr4	SCr430(H)	SCr430(H)	
	41Cr4	42Cr4	SCr440(H)	SCr440(H)	
2245	41Cr4	42Cr4	SCr440	SCr440	
2511	16MnCr5	16MnCr5			
2127					
2253			SUP9(A)	SPS 9(A)	
2234					
	41CrMo4	42CrMo4	SNB 22-1	SNB 22-1	
2244					
2512	653M31				
2216		12CrMo4			
2625					
	14CrMo4 5	14CrMo45			
2216		12CrMo4	SCM415(H)	SCM415(H)	
2218	12CrMo9,10	TU.H 13MoCrV6			
2940	41CrAlMo7	41CrAlMo7			
1312	Fe 360 B FN	AE 235 B FN;FU Fe 360 B FN; FU			St3ps; sp

Material Conversion Table





► According to VDI 3323 standard

Material group					
	AISI/SAE	Material No. DIN	BS	EN	AFNOR
7		1.5755 31 NiCr 14	653 M 31		18 NC 13
7	8620	1.6523 2 NiCrMo2	805M20	362	20 NCD 2
7	8740	1.6546 40 NiCrMo 22	311-Tyre 7		
7	4130	1.7218 25CrMo4	CDS 110		25 CD 4
7		1.7733 24 CrMoV 5 5			20 CDV 6
7		1.7755 GS-45 CrMOV 10 4			
7		1.8070 21 CrMoV 5 11			
8	4142	1.2332 47 CrMo 4	708 M 40	19A	42 CD 4
8	A128 (A)	1.3401 G-X120 Mn 12			Z 120 M 12
8	3435	1.5736 36 NiCr 10			30 NC 11
8	9840	1.6511 36CrNiMo4	816M40	110	40NCD3
8	4340	1.6582 35CrNiM 6	817 M 40	24	35 NCD 6
8		1.7361 32 CeMo12	722 M 24	40B	30 CD 12
8	6150	1.8159 50 CrV 4	735 A 50	47	50CrV4
8		1.8161 58 CrV 4			
8		1.8515 32 CrMo 12	722 M 24	40B	30 CD 12
8		1.8523 39CrMoV13 9	897M39	40C	
9		1.4882 X 50 CrMnNiNbN 21 9			Z 50 CMNNb 21.09
9	3135	1.5710 36NiCr6	640A35	111A	35NC6
9		1.5864 35 niCr 18			
9		31 NiCrMo 13 4	830 m 31		
10	A573-81	1.0144 ST 44-3	4360 43 C		E 28-3
10	A 619	1.0347 DCO3 RSt;RRSt 13	1449 3 CR 1449 2 CR		E
10	M 1015 M 1016 M 1017	1.0401 C15	080 M 15 080 M 15 1449 17 CS		AF 37 C12 XC 18
10		1.0570 ST 52-3	4360 50 B		E 36-3
10	12L13	1.0718 9SMnPb28			S250Pb
10	(12L13)	1.0718 9 SMnPb 28			S 250 Pb

					
SS	UNI	UNE	JIS	KS	GOST
2506	20NiCrMo2	20NiCrMo2	SNM220(H)	SNM220(H)	
	40NiCrMo2(KB)	40NiCrMo2	SNM240	SNM240	
2225	25CrMo4(KB)	55Cr3	SCM420/430	SCM420/430	
	21 CrMoV 5 11				
	35 NiCr 9				
2244	42CrMo4	42CrMo4	SCM (440)	SCM (440)	
2183	GX120Mn12	F. 8251-AM-X120Mn12	SCMnH 1, SCMn H 11	SCMnH 1, SCMn H 11	110G13L
	36NiCrMo4(KB)	35NiCrMo4	SUP 10	SPS 10	
2541	35NiCrMo6(KB)		SNM 447	SNM 447	
2240	30CrMo12	F.124.A			
2230	50CrV4	51CrV4			
2240	32CrMo12	F.124.A			
	36CrMoV12				
			SNC236	SNC236	
2534		f-1270			
1412			SM 400A;B;C	SM 400A;B;C	
	Fep 02	AP 02			08JU
1350	C15				
	C16	F.111	S 15 C	SM 15 C	
	1 C 15				
2132	Fe52BFN/Fe52CFN		SM490A;B;C;YA;YB	SM490A;B;C;YA;YB	
1914	CF9SMnPb28	11SMnPb28			
1914	CF 9 SMnPb 28	11 SMnPb 28	SUM 22L	SUM 22L	

Material Conversion Table





► According to VDI 3323 standard







Material group					
	AISI/SAE	Material No. DIN	BS	EN	AFNOR
10		1.0723 15 S 22 15 S 20	210 A 15 210 M 15		
10		1.2083			
10	H 11	1.2343 x 38 CrMoV 5 1	BH 11		Z 38 CDV 5
10	H 13	1.2344 X 40 CrMoV 5 1	BH 13		Z 40 CDV 5
10	A 2	1.2363 X100 CrMoV 5 1	BA 2		Z 100 CDV 5
10	D 2	1.2379 X 155 CrVMo 12 1	BD2		Z 160 CDV 12
10	HNV3	1.2379 X210Cr12G	BD2		Z160CDV12
10	D 4 (D 6)	1.2436 X 210 CrW 12	BD6		Z 200 CD 12
10	H 21	1.2581 X 30 WCrV 9 3	BH 21		Z 30 WCV 9
10		1.2601 X 165 CrMoV 12			
10	H 12	1.2606 X 37 CrMoW 5 1	BH 12		Z 35 CWDV 5
10	D3	1.3343 S 6-5-2	BM2		Z200C12
10	N08028	1.4563			Z1NCDU31-27-03
10	ASTM A353	1.5662 X8Ni9	1501-509;510		
10	ASM A353	1.5662 X8Ni9	502-650		9 Ni
10	2517	1.5680 12Ni19	12Ni19		Z18N5
10	2515	1.5680 12 Ni 19			Z 18 N 5
11		1.3202 S 12-1-4-5	BT 15		
11		1.3207 S 10-4-3-10	BT 42		Z130WKCDV
11	T15	1.3243 S 6-5-2-5			KCV 06-05-05-04-02
11		1.3246 S 7-4-2-5			Z110 WKCDV 07-05-04
11		1.3247 S 2-10-1-8	BM 42		Z110 DKCWV 09-08-04
11	M 42	1.3249 S 2-9-2-8	BM 34		
11	T 4	1.3255 S 18-1-2-5	BT 4		Z 80 WKCV 18-05-04-0
11	M 2	1.3343 S6-5-2	BM2		Z 85 WDCV
11	M 7	1.3348 S2-9-2			Z 100 DCWV 09-04-02-

 SS	 UNI	 UNE	 JIS	 KS	 GOST
1922		F.210.F	SUM 32	SUM 32	
2314	X 37 CrMoV 5 1 KU				
2242	X40CrMoV511KU	F-5318	SKD61	STD61	
2260	X100CrMoV51KU	F-5227	SKD12	STD12	
2310	X165CrMoW12KU	X160CrMoW12KU			
2736					
2312	X215CrW 12 1 KU	F-5213			
	X30WCv 9 3 KU	F-526	SKD5	STD5	
2310	X 35 CrMoW 05 KU	F.537			
2715	X210Cr13KU	X210Cr12	SUH3	STR3	
2584	14 Ni 6 KG;KT	XBNI09			
	X10Ni9	F-2645	SL9N60(53)	SL9N590(520)	
	HS 12-1-5-5	12-1-5-5			
2723	HS 6-5-2-5	6-5-2-5	SKH55	SKH55	
7-4-2-5	HS 7-4-2-5	M 35			
2-10-1-8	HS 2-9-1-8 2-9-2-8	M 41			
2722	HS 652	F-5604	SKH 51	SKH 51	
2782	HS 292	F-5607			

Material Conversion Table





► According to VDI 3323 standard

Material group					
	AISI/SAE	Material No. DIN	BS	EN	AFNOR
11	T 1	1.3355 S 18-0-1	BT 1		Z 80 WCV 18-4-01
11	630	1.4548			Z7CNU17-04
11	HNV 3	1.4718 X45CrSi 9 3	401S45	52	Z45CS9
11	422	1.4935 x20 CrMoWV 12 1			
12	403	1.4000 X6Cr13	403 S 17		Z 6 C 13
12		1.4001 X6Cr14			
12	(410S)	1.4001 X7 Cr 13	(403 S 7)		Z 8 C 13
12	405	1.4002 X6CrA12	405S17		Z8CA12
12	405	1.4002 X6 CrAl 13	405 S 17		Z6CA13
12	416	1.4005 X12CrS 13	416 S 21		Z11 CF 13
12	410; CA-15	1.4006 (G-)X10 Cr 13	410S21	56A	Z10 C 13
12	430	1.4016 X8Cr17	Z8C17		430S15
12	430	1.4016 X6 Cr 17	430 S 15	60	Z 8 C 17
12		1.4027 G-X20Cr14	420 C 29		Z20 C 13M
12		1.4027 G-X 20 Cr 14	420 C 29		Z 20 C 13M
12	420	1.4028 X30 Cr 13	420 S 45		Z 30 C 13
12		1.4086 G-X120Cr29	452C11		
12	430 F	1.4104 X12CrMoS17	420 S 37		Z 10 CF 17
12	440B	1.4112 X90 CrMoV 18			
12	434	1.4113 X6CrMo 17	434 S 17		Z 8 CD 17.01
12		1.4340 G-X40CrNi27 4			
12	S31500	1.4417 X2CrNiMoSi19 5			
12	S31500	1.4417 X2 CrNoMoSi 18 5 3			
12		1.4418 X4 CrNiMo16 5			Z6CND16-04-01
12	XM 8	1.4510			Z 4 CT 17
	430 Ti				
	439				
12	430tl	1.4510 X6 CrTi 17			Z 4 CT 17
12		1.4511 X 6 CrNb 17(X 6 CrNb 17			Z 4 C Nb 17
12	409	1.4512 X 6 CrTi 12 (X2CrTi12)	LW 19 409 S 19		Z 3 CT 12
12		1.4720 X20CrMo13			

					
SS	UNI	UNE	JIS	KS	GOST
	X45CrSi8	F322	SUH1	STR1	
2301	X6Cr13	F.3110 F8401	SUS403	STS 403	
2301	X6CrAl13				
2302	X6CrAl13				
2380	X12 CrSC13	F-3411	SUS 416	SUS 416	
2302	X12Cr13	F.3401	SUS 410	SUS 410	
2320	X8Cr17	F.3113			
2320	X8Cr17	F.3113	SUS 430	SUS 430	
2304					
2383	X10CrS17	F.3117	SUS430F	STS 430F	
2325	X8CrMo17		SUS434	STS 434	
2376					
2376					
2387	X 6 CrTi 17	F.3115-X 5 CrTi 17	SUS 430 LK	STS 430 LX	08 Ch17T
	X 6 CrNb 17	F.3122-X 5 CrNb 17	SUS 430 LK	STS 430 LX	
	X 6 CrTi 17		SUH 409	STR 409	

Material Conversion Table





► According to VDI 3323 standard







Material group					
	AISI/SAE	Material No. DIN	BS	EN	AFNOR
12	405	1.4724 X10CrA113	403S17		Z10C13
12	430	1.4742 X10CrA118	439S15	60	Z10CAS18
12	HNV6	1.4747 X80CrNiSi20	443S65	59	Z80CSN20.02
12	446	1.4749 x18 cRn 28			
12	446	1.4762 X10CrA124			Z10CAS24
12	EV 8	1.4871 X 53 CrMnNiN 21 9	349 S 54		Z 52 CMN 21.09
12	302	x12 CrNi 18 9	302 S 31		Z 10 CN 18-09
12	429	X10 CrNi 15			
13	420	1.4021 X20Cr13	420S37		Z 20 C 13
13	420	1.4031 X40 Cr 13			Z 40 C 14
13		1.4034 X46Cr13	420 S 45		Z40 C 14
13	431	1.4057 X20CrNi172	431 S 29	57	Z 15 CN 16.02
13		1.4125 X 105 CrMo 17			Z 100 CD 17
13	CA6-NM	1.4313 G-X4 CrNi 13 4	425 C 11		Z 4 CND 13-04 M
13	630	1.4542 X 5 CrNiCuNb 17 4 (X5CrNiCuNb 16-4)			
13		1.4544	S. 524 S. 526		
13	348	1.4546 X5CrNiNb 18-10	347 S 31 2 S. 130 2 S. 143/144/145 S.525/527		
13		1.4922 x20cRmV12-1			
13		1.4923 X22 CrMoV12 1			
14	304	1.4301 X 5 CrNi 18 9	304 S 15		Z 5 CN 18.09
14	303	1.4305 X10 CrNiS 18 9	303 S 21	58M	Z 8 CNF 18-09
14	304L	1.4306 X2CrNi18 9	304S12		Z2CrNi18 10
14	304L	1.4306 X2 CrNi 18 10	304 S 11		Z 3 CN 19-11
14	CF-8	1.4308 X6 CrNi 18 9	304 C 15	58E	Z 6 CN 18-10 M
14	301	1.4310 X12CrN i17 7	301 S 21		Z 12 CN 17.07

					
SS	UNI	UNE	JIS	KS	GOST
	X10CrA112	F.311			
	X8Cr17	F.3113	SUS430	STS430	
	X80CrSiNi20	F.320B	SUH4	STR4	
2322	X16Cr26		SUH446	STR446	
	X53CrMnNiN21 9		SUH35,SUH36	STR35,STR36	
2330					
2303	14210				
-2304					
	X40Cr14	F.3405	SUS420J2	STS420J2	
2321	X16CrNi16	F.3427	SUS431	STS431	
	X 105 CrMo 17				
2385	(G)X6CrNi304		SCS5	SSC5	
	X 6 CrNiTi 18 11				08Ch 18N12T
	X 6 CrNiNb 18 11				
2317	x20cRmOnl 12 01				
2332;2333					
2346	X10CrNiS18.09	F.3508	SUS303	STS303	
2352	x2cRnI18 11	F.3503	SCS19	SSC19	
2352	X2CrNi18 11				
2333			SUS304L	STS304L	
2331	X2CrNi18 07	F.3517			

Material Conversion Table





► According to VDI 3323 standard







Material group					
	AISI/SAE	Material No. DIN	BS	EN	AFNOR
14	304 LN	1.4311 X2 CrNiN 18 10	304 S 62		Z 2 CN18.10
14		1.4312 G-X10CrNi18 8	302C25		Z10CN18.9M
14	305	1.4312 X8 CrNi 18 12	305 S 19		
14		1.4332 X2 CrNi 18-8			
14	304	1.4350 X5CrNi18 9	304S15	58E	Z6CN18.09
14	S32304	1.4362 X2 CrNiN 23 4			Z 2 CN 23-04 AZ
14	202	1.4371 X3 CrMnNiN 188 8 7	284 S 16		Z 8 CMN 18- 08-05
14	316	1.4401 X 5 CrNiMo 17 12 2 (X4 CrNiMo 17 -12-2)	316 S 13 316 S 17 316 S 19 316 S 31 316 S 33		Z 3 CND 17 -11-01 Z 6 CND 17-11 Z 6 CND 17-11-02 Z 7 CND 17-11-02 Z 7 CND 17-12-02
14	316L	1.4404 X2 CrNiMo 17 13 2 (X2 CrNiMo 17-12-2) GX 2 CrNiMoN 18-10	316 S 11, 316 S 13 316 S 14, 316 S 31; 316 S 42, S.537;316 C 12, T.75, S. 161		Z 2 CND 17-12 Z 2 CND 18-13 Z 3 CND 17-11-02 Z 3 CND 17-12-02 FF Z 3 CND 18-12-03 Z 3 CND 19.10 M
14	316LN	1.4406 X2 CrNiMoN 17 12 2 (X2CrNiMoN 18-10)	316 S 61 316 S 63		Z2 CND 17-12 AZ
14	CF-8M	1.4408 GX 5 CrNiMoN 7 12 2 G-X 6 CrNiMo 18 10	316 C 16 (LT 196) ANC 4 B		
14		1.4410 G-X10CrNiMo18 9			Z5CNaD20.12M
14	316 Ln	1.4429 X2 CrNiMo 17 -13-3	316 S 62		Z 2 CND 17-13 Az
14	316L	1.4435 X2 CrNiMo18 14 3	316 S 11;316 S 13 316 S 14;316 S 31 LW 22 LWCF 22		Z 3 CND 17-12-03 Z 3 CND 18-14-03
14	316	1.4436 X 5 CrNiMo 17 13 3 (X4CRNIMO 17-13-3)	316 S 19;316 S 31 316 S 33 LW 23 LWCF 23		Z 6 CND 18-12-03 Z 7 CND 18-12-03

					
SS	UNI	UNE	JIS	KS	GOST
2371	X2CrNi18 10		SUS304LN	STS304LN	
2332	X5CrNi18 10	F.3551	SUS304	STS304	
2347	X 5 CrNiMo 17 12	F.3534-X 5 CrNiMo 17 12 2	SUS 316	STS 316	
2348	X 2 CrNiMo 17 12	F.3533 - X 2 CrNiMo 17 13 2			
	G-X 2 CrNiMo 19 11	F.3537 - X 2 CrNiMo 17 13 3	SUS 316 L	STS 316 L	
	X 2 CrNiMoN 17 12	F.3542-X 2 CrNiMoN 17 12 2	SUS316LN	STS316LN	
2343		F.8414-AM-X 7 CrNiMo 20 10	SCS 14	SSC 14	07 Ch 18N10G2S2MSL
2328					
2375	X 2 CrNiMoN 17 13	F.3543-X 2 CrNiMoN 17 13 3	SUS 316 LN	STS 316 LN	
2375	X 2 CrNiMoN 17 13	F.3533-X 2 CrNiMo 17 13 2	SUS 316 L	STS 316 L	O3 Ch 17N14M3
2343	X 5 CrNiMo 117 13	F.3543-X 5 CrNiMo 17 12 2	SUS 316	STS 316	
	X 8 cRnImO 17 13	F.3538-X 5 CrNiMo 17 13			

Material Conversion Table

► According to VDI 3323 standard







Material group	 AISI/SAE	 Material No. DIN	 BS	 EN	 AFNOR
14	317L	1.4438 X2 CrNiMo 18 16 4 (X2CrNiMo 18-15-4)	317 S 12		Z 2 CND 19-15-04 z 3 cnd 19-15-04
14	(s31726)	1.4439 X2 CrNiMoN 17 13 5			Z 3 CND 18-14-06 AZ
14		1.4440 X 2 CrNiMo 18 13			
14	317	1.4449 X5 CrNiMo 17 13 3	317 S 16		
14	329	1.4449 X 4 CrNiMo 27 5 2 1.4460 (X3CrNiMo27-5-2)			(Z 3 CND 25-07 Az) Z 5 CND 27-05 Az
14	329	1.4460 X8CrNiMo27 5			
14		1.4462 X2CrNiMoN22 5 3	318 S 13		Z 3 CND 22-05 Az (Z 2 CND 24 -08 Az) (Z 3 CND 25-06-03 Az)
14		1.4500 G-X7NiCrMoCuNb25 20			Z3NCDU25.20M
14	17-7PH	1.4504	316S111		
14	443 444	1.4521 X2CrMoTi18-2	317 S 16		
14	UNS N 08904	1.4539 X1NiCrMoCuN25-20-5			Z 2 NCDU 25-20
14	CN-7M	1.4539 (G-)X1 NiCrMoCu 25 20 5			Z1 NCDU 25-02 M
14	321	1.4541 Z 6 CrNiTi 18-10	321 S 31 321 S 51 (1010;1105) LW 24 LWCF 24		Z 6 CNT 18-10
14	630	1.4542 X5 CrNiCuNb 17 4 (X5 CrNiChNb 16-4)			Z 7 CNU 15-05 Z 7 CNU 17-04
14	17-4PH	1.4542			Z7CNU17-04
14	S31254	1.4547 X1 CrNiMoN 20 18 7			
14	17-4PH	1.4548			Z7CNU17-04
14	347	1.4550 X6 CrNiNb 18 10	347 S 17	58F	Z 6 CNNb 18.10
14		1.4552 G-X7CrNiNb18 9			Z4CNNb19.10M
14	17-7PH	1.4568	316S111		
14	316Ti	1.4571 X6 CrNiMoTi 17 12 2	320 S 31		Z 6 CNDT 17-12002
14		1.4581 G-X 5 CrNiMoNb	318 C 17		Z 4 CNDNb 18.12 M
14	318	1.4583 X 10CrNiMoNb 18 12	303 S 21		Z15CNS20.12

 SS	 UNI	 UNE	 JIS	 KS	 GOST
2367	X2CrNiMo18 16	f.3539-x 2 cRnlmO 18 16 4	SUS317L	STS317L	
	X 5 CrNiMo 18 15		SUS 317	STS 317	
2324		F.3309-X 8 CrNiMo 17 12 2 F.3552-X 8 CrNiMo 18 16 4	SUS 329 J 1	STS 329 J 1	
2377			SUS 329 J3L	STS 329 J3L	
	Z8CNA17-07	X2CrNiMo1712			
2326		F.3123-X 2 CrMoTiNb 18 2	SUS 444	STS 444	
2562					
2564					
2337	X 6 CrNiTi 18 11	F.3523 - X 6 CrNiTi 18 10	SUS 321	STS 321	06Ch18N10T 08Ch18N10T 09Ch18N10T 12Ch18N10T
			SCS 24 SUS 630	SSC 24 STS 630	
2378					
2338	X6CrNiNb18 11	F.3552	SUS347	STS347	
	Z8CNA17-07	X2CrNiMo1712			
2350					
	x15cRnIsl2 12				

Material Conversion Table





► According to VDI 3323 standard







Material group					
	AISI/SAE	Material No. DIN	BS	EN	AFNOR
14		1.4585 G-X7CrNiMoCuNb18 18			
14		1.4821 X20CrNiSi25 4			Z20CNS25.04
14		1.4823 G-X40CrNiSi27 4			
14	309	1.4828 X15CrNiSi20 12	309 S 24	58C	Z15CNS20.12
14	309S	1.4833 X6 CrNi 22 13	309 S 13		Z 15 CN 24-13
14	310 S	1.4845 X12 CrNi 25 21	310S24		Z 12 CN 25-20
14	321	1.4878 X6 CrNiTi 18 9	32 1 S 20	58B	Z 6 CNT 18-12 (B)
14	Ss30415	1.4891 X5 CrNiNb 18 10			Z20CNS25.04
14	S30815	1.4893 X8 CrNiNb 11			
14	304H	1.4948 X6 CrNi 18 11	304 S 51		Z 5 CN 18-09
14	660	1.498 X5 NiCrTi 25 15			Zz 8 nctv 25-15 b ff
14		X5 NiCrN 35 25			
14	S31753	X2 CrNiMoN 18 13 4			
14		X2 CrNiMoN 25 22 7			
15	CLASS20	0.6010 GG10			Ft10D
15	A48-20B	0.6010 GG-10			Ft 10 D
15	NO 25 B	0.6015 GG 15	Grade 150		Ft 15 D
15	CLASS25	0.6015 GG 15	Grade 150		Ft 15D
15	A48 25 B	0.6015 GG 15	Grade 150		Ft 15 D
15	A48-30B	0.6020 GG-20	Grade 220		Ft 20 D
15	NO 30 B	0.6020 GG 20	Grade 220		Ft 20 D
15	A436 Type 2	0.6660 GGL-NiCr202	L-NiCuCr202		L-NC 202
15	60-40-18	0.7040 GGG 40	SNG 420/12		FCS 400-12
15	No 20 B	GG 10			Ft 10 D
16	CLASS30	0.6020 GG 20	Grade 220		Ft 20D
16	CLASS45	0.6030 GG 30	Grade 300		Ft 30D
16	A48-45 B	0.6030	Grade 350		Ft 30D
16	A48-50	0.6035 GG-35	Grade 350		Ft 35 D
16	A48-60 B	0.6040 GG40	Grade 400		Ft 40 D
16	100/70/03	0.7070 GGG-70	SNG700/2		FGS 700-2

 SS	 UNI	 UNE	 JIS	 KS	 GOST
	X6CrNiMoTi17 12				
		F.8414	SCS17	SSC17	
2361	X6CrNi25 20	F.331	SUH310	STR310	
2337	X6CrNiTi18 11	F.3553	SUS321	STS321	
2372					
2368					
2333					
2570					
110	G 10				
0110-00					
0115-00	G 15	FG 15	FC150	GC150	
115	G 15	FG 15			
01 15-00	G 14	FG 15			
0120-00					
120	G 20		FC200	GC200	
0523-00					
0717-02	GS 370-17	FGE 38-17	FCD400	GCD400-18,15	
110			FC100	GC100	
120	G 20	FG 20			
130	G 30	FG 30	FC300	GC300	
01 30-00					
135	G 35	FG 35	FC350	GC350	
140					
07 37-01	GGG 70	GGG 70	FCD700	GCD700-2	

Material Conversion Table





► According to VDI 3323 standard







Material group					
	AISI/SAE	Material No. DIN	BS	EN	AFNOR
16		1.4829 X 12 CrNi 22 12			
17		0.7033 GGG35.3			
17		0.7033 GGG-35.3	350/22 L 40		FGS 370/17
17	60-40-18	0.7040 GGG-40	SNG 420/12		FGS 400-12
17	60/40/18	0.7043 GGG-40.3	370/7		FGS 370/17
17	80-55-06	0.7050 GGG50	SNG500/7		FGS 500/7
17	65-45-12	0.7050 GGG-50	SNG 500/7		FGS 500-7
17		0.7652 GGG-NiMn 13 7	S-NiMn 137		S-Mn 137
17	A43D2	0.7660 GGG-NiCr 20 2	Grade S6		S-NC 202
17		GGG 40.3	SNG 370/17		FGS 370-17
18	A48-40 B	0.6025 GG25	Grade260		Ft 25 D
18		0.7060 GGG60	SNG600/3		FGS600-3
18	80/55/06	0.7060 GGG-60	600/3		FGS 600/3
18	A48 40 B				
19		0.8055 GTW55			
19	32510	0.8135 GTS-35-10	B 340/12		MN35-10
19	A47-32510	0.8135 GTS-35-10	B 340/2		Mn 35-10
19	A220-40010	0.8145 GTS-45-06	P 440/7		Mn 450-6
19		GTS-35	B 340/12		
19			8 290/6		MN 32-8
19	32510	GTS-35	B340/12		MN 35-10
20		0.8035 GTM-35	W340/3		MB35-7
20		0.8040 GTW-40	W410/4		MB40-10
20		0.8045			
20		0.8065 GTMW-65			
20	A220-50005	0.8155 GTS-55-04	P 510/4		Mn 550-4
20	50005	0.8155 GTS-55-04	P 510/4		MP 50-5
20	70003	0.8165 GTS-65-02	P 570/3		Mn 650-3
20	90001	0.8170 GTS-70-02	P 690/2		Mn 700-2
20	A220-90001	0.8170 GTS-70-02			Mn 700-2

					
SS	UNI	UNE	JIS	KS	GOST
0717-15					
0717-15					
0717-02					
0717-15					
0727-02	GGG 50				
	0727-02		FCD 500	GCD 500-7	
0772-00					
0776-00					
0717-12					
125	G 25	FG 25	FC250	GC250	
07 32-03	GGG 60	GGG 60			
0727-03			FCD600	GCD600-3	
		GTW 55			
810		GTS 35			
0815-00					
	0852-00	GMN 45			FCMW370
0810-00					
814			AC4A	AC4A	
08 15			FCMW330	FCMW330	
852		GTM 35			
	GTB40	GTM 40			
	GMB45	GTM 45			
		GTM 65			
0854-00					
0854-00	GMN 55		FCMP490	PMC 490	
0856-00	GMN 65		FCMP590	PMC 590	

Material Conversion Table





► According to VDI 3323 standard

Material group					
	AISI/SAE	Material No. DIN	BS	EN	AFNOR
20		0.8170 GTS-70-02	IP 70-2		
20	1022				
	1518	1.1133 20Mn5	120 M 19		20 M 5
20	1035	1.1183 Cf 35 (C35G)	080 A 35		XC 38 H 1 TS
20	400 10	GTS-45	P440/7		
20	70003	GTS-65	P 570/3		MP 60-3
21	Al99	3.0205			
21	1000	3.0255 Al99.5	L31/34/36		A59050C
21		3.3315 AlMg1			
22		3.1325 AlCuMg 1			
22		3.1655 AlCuSiPb			
22		3.2315 AlMgSi1			
21	7050	3.4345 AlZnMgCuO,5	L 86		AZ 4 GU/9051
23		3.2381 G-AlSi 10 Mg			
23		3.2382 GD-AlSi10Mg			
23		3.2581 G-AlSi12			
23		3.3561 G-ALMg 5			
23	ZE 41	3.5101 G-MgZn4sE1Zr1	MAG 5		
23	EZ 33	3.5103 MgSE3Zn27r1	MAG 6		G-TR3Z2
23	AZ 81	3.5812 G-MgAl8Zn1	NMAG 1		
23	AZ 91	3.5912 G-MgAl9Zn1	MAG 7		
24		2.1871 G-AlCu 4 TiMg			
24		3.1754 G-AlCu5Ni1,5			
24		3.2163 G-AlSi9Cu3			
24	4218 B	3.2371 G-AlSi 7 Mg			
24	SC64D	3.2373 G-AlSi9MGWA			A-S7G
24		3.2373 G-AlSi 9 Mg			
24	QE 22	3.5106 G-MgAg3SE2Zr1	mag 12		
24	GD-AlSi12	G-ALMG5	LM5		A-SU12
23-24	A360.2	3.2383 G-AlSi0Mg(Cu)	LM9		

 SS	 UNI	 UNE	 JIS	 KS	 GOST
0862-00	GMN 70		FCMP690	PMC 690	
0864-00					
2132	G 22 Mn 3				
	20 Mn 7	F.1515-20 Mn 6	SMnC 420	SMnC 420	
1572	C 36; C 38		S 35 C	SM 35 C	35
08 52					
858			FCMP540	PMC 540	
811-04					
4231			C4BS	C4BS	
4252					
4253					





Material Conversion Table

► According to VDI 3323 standard

				
Material group	AISI/SAE	Material No. DIN	BS	EN
				AFNOR
23-24	A356-72		2789;1973	NF A32-201
23-24	356.1		LM25	
23-24	A413.2	G-AISi12	LM6	
23-24	A413.1	G-AISi 12 (Cu)	LM20	
23-24	A413.0	GD-AISi12		
23-24	A380.1	GD-AISi8Cu3	LM24	
26	C93200	2.1090 G-CuSn 7 5 pb		U-E 7 Z 5 pb 4
26	C83600	2.1096 G-CuSn5ZnPb	LG 2	
26	C83600	2.1098 G-CuSn 2 Znpb		
26	C23000	2.1182 G-CuPb15Sn	LB1	U-pb 15 E 8
26	C93800	2.1182 G-CuPb15Sn		Uu-PB 15e 8
27		2.0240 CuZn 15		
27	C27200	2.0321 CuZn 37	cz 108	CuZn 36, CuZn 37
27	C27700	2.0321 CuZn 37	cz 108	CuZn 36, CuZn 37
27		2.0590 G-CuZn40Fe		
27	C 86500	2.0592 G-CuZn 35 Al 1	U-Z 36 N 3	HTB 1
27	C 86200	2.0596 G-CuZn 34 Al 2	HTB 1	U-Z 36 N 3
27	C 18200	2.1293 CuCrZr	CC 102	U-Cr 0.8 Zr
28		2.0060 E-Cu57		
28		2.0375 CuZn36Pb3		
28	C 94100	2.0596 G-CuZn 34 Al 2	HTB 1	U-Z 36 N 3
28	C 63000	2.0966 CuAl 10 Ni 5 Fe 4	Ca 104	U-A 10 N
28	B-148-52	2.0975 G-CuAl 10 Ni		
28	C 90700	2.105 G-CuSn 10	CT1	
28	C 90800	2.1052 G-CuSn 12	pb 2	UE 12 P
28	C 81500	2.1292 G-CuCrF 35	CC1-FF	
28		2.4764 CoCr20W15Ni		
31	N 08800	1.4558 X 2 NiCrAlTi 32 20	NA 15	
31	N 08031	1.4562 X 1 NiCrMoCu 32 28 7		





Material Conversion Table







► According to VDI 3323 standard

Material group					
	AISI/SAE	Material No. DIN	BS	EN	AFNOR
31	N 08028	1.4563 X 1 NiCrMoCuN 32 27 4			
31	N 08330	1.4564 X 12 NiCrSi 36 16	NA 17		Z 12 NCS 35.16
31	330	1.4564 X12 NiCrSi 36 16	NA 17		Z 12 NCS 37.18
31		1.4865 G-X40NiCrSi38 18	330 C 40		
31		1.4958 X 5 NiCrAlTi 31 20			
31	AMS 5544	LW2.4668 NiCr19NbMo			NC20K14
32		1.4977 X 40 CoCrNi 20 20			Z 42 CNKDOWNb
33	Monel 400	2.4360 NiCu30Fe	NA 13		NU 30
33	5390A	2.4603			NC22FeD
33	Hastelloy C-4	2.4610 NiMo16Cr16Ti			
33	Nimonic75	2.4630 NiCr20Ti	HR 5,203-4		NC 20 T
33		2.4630 NiCr20Ti	HR5,203-4		NC20T
33	Inconel 690	2.4642 NiCr29Fe			Nnc 30 Fe
33	Inconel 625	2.4856 NiCr22Mo9Nb	NA 21		NC 22 FeDNb
33	5666	2.4856 NiCr22Mo9Nb			Inconel 625
33	Incoloy 825	2.4858 NiCr21Mo	NA 16		NC 21 Fe DU
34	Monel k-500	2.4375 NiCu30 Al	NA 18		NU 30 AT
34	4676	2.4375 NiCu30Al	3072-76		
34		2.4631 NiCr20TiAl	Hr40;601		NC20TA
34	Inconel 718	2.4668 NiCr19FeNbMo			NC 19 Fe Nb
34	Inconel	2.4694 NiCr16fE7TiAl			
34		2.4955 NiFe25Cr20NbTi			
34	5383	LM2.4668 NiCr19Fe19NbMo	HR8		NC19eNB
34	5391	LW2 4670 S-NiCr13A16MoNb	3146-3		NC12AD
34	5660	LW2.4662 NiFe35Cr14MoTi			ZSNCDT42
34	5537C	LW2.4964 CoCr20W15Ni			KC20WN
34	AMS 5772	C0Cr22W14Ni			KC22WN
35	Inconel X-750	2.4669 NiCr15Fe7TiAl			NC 15 TNb A
35	Hastelloy B	2.4685 G-NiMo28			
35	Hastelloy C	2.4810 G-NiMo30			

Material Conversion Table

► According to VDI 3323 standard

Material group				
	AISI/SAE	Material No. DIN	BS	EN AFNOR
35	AMS 5399	2.4973 NiCr19Co11MoTi		NC19KDT
35		3.7115 TiAl5Sn2		
36	R 50250	3.7025 Ti 1	2 TA 1	
36	R 52250	3.7225 Ti 1 pd	TP 1	
36	AMS 5397	LW2 4674 NiCo15Cr10MoAlTi		
37		3.7124 TiCu2	2 TA 21-24	
37	R 54620	3.7145 TiAl6Sn2Zr4Mo2Si		
37		3.7165 TiAl6V4	TA 10-13;TA 28	T-A 6 V
37		3.7185 TiAl4Mo4Sn2	TA 45-51; TA 57	
37		3.7195 TiAl 3 V 2.5		
37		TiAl4Mo4Sn4Si0.5		
37	AMS R54520	TiAl5Sn2.5	TA14/17	T-A5E
37	AMS R56400	TiAl6V4	TA10-13/TA28	T-A6V
37	AMS R56401	TiAl6V4ELI	TA11	
38	W 1	1.1545 C105W1	BW 1A	Y1105
38	W210	1.1545 C105W1	BW2	Y120
38		1.2762 75 CrMoNiW 6 7		
38	440C	1.4125 X105 CrMo 17		Z 100 CD 17
38		1.6746 32 nlcRmO 14 5	832 M 31	35 NCD 14
40	Ni- Hard 2	0.9620 G-X 260 NiCr 4 2	Grade 2 A	
40	Ni- Hard 1	0.9625 G-X 330 Ni Cr 4 2	Grade 2 B	
40	Ni- Hard 4	0.9630 G-X 300 CrNiSi 9 5 2		
40		0.9640 G-X 300 CrMoNi 15 2 1		
40	A 532 III A 25% Cr	0.9650 G-X 260 Cr 27	Grade 3 D	
40	A 532 III A 25% Cr	0.9655 G-X 300 CrNMo 27 1	Grade 3 E	
40		1.2419 105 WCr 6	105WC 13	
40	310	1.4841 X15 CrNiSi 25 20	314 S31	Z 15 CNS 25-20
41		0.9635 G-X 300 CrMo 15 3		
41		0.9645 G-X 260 CrMoNi 20 2 1		
41		0.9655 G-X 300 CrNMo 27 1		

 SS	 UNI	 UNE	 JIS	 KS	 GOST
1880	C100KU	F-5118	SK3	STC 105(STC3)	
2900	C120KU	CF.515	SUP4	SPS 4	
	0512-00				
	0513-00				
	0466-00				
		107 WCr 5 KU			

TaeguTec Supply Network

World Headquarters

TaeguTec Ltd.

1040 Gachang-ro, Gachang-myeon,
Dalseong-gun, Daegu, 42936, Korea
Tel: +82-53-760-7639
Web: <http://www.taegutec.com>

Argentina

TaeguTec Argentina SA

11 de septiembre 4237- Piso 7
(C1429BJC) Ciudad Autónoma
Buenos Aires, Argentina
Tel: +54-11-4702-6222
E-mail: ventas@taegutec.com.ar

Australia

TaeguTec Australia Pty Ltd.

14/345 Plummer Street,
Port Melbourne, VIC 3207, Australia
Tel: +61-1300-811-080
E-mail: sales@taegutec.com.au

Belarus Rep.

Twing-M ALC

Slutskaia str 3, Minsk Area, 223056,
Village Senitsa, Republic of Belarus
Tel: +375-17-506-3238
E-mail: info@twing.by

Brazil

TaeguTec Do Brasil LTDA.

Rua Francisco Foga 500, 13288166
Dist Ind Benedito Storani, Vinhedo, Brazil
Tel: +55-11-3868-6032
E-mail: vendas@taegubrasil.com.br

Bulgaria

Tekotek BG Ltd.

Alexander Stamboliyski No 31,
7700 Targovishte, Bulgaria
Tel: +359-878-05-1818
E-mail: tekotekbg@gmail.com

Chile

Cutting Tools Chile SpA

Alcalde Pedro Alarcón N° 765,
San Miguel, Santiago - Chile
Tel: +56-2-553 6944
E-mail: ventas@cuttingtools.cl

China

TaeguTec Cutting Tools Trading

(Shanghai) Co., Ltd.

RM 1706, T1 Building, Global Creative
Center, No. 166 Minghong RD, Minhang
District, Shanghai, China
Zip Code : 201102
Tel: +86-21-5106-1260
E-mail: mail@taegutec.com.cn

Croatia

Intehna Zagreb D.O.O.

Samoborska cesta 255, 10090
Zagreb-Susedgrad, Croatia
Tel: + 385-1-3436-919
E-mail: info@intehna.hr

Czech Rep.

TaeguTec CR S.R.O.

Domažlická 180a, CZ-31800 Plzeň,
Czech Rep.
Tel: +420-373-720-999
E-mail: top@taegutec.cz

Denmark

TaeguTec Scandinavia A/S.

Hollandsvej 12, Room 206
DK-2800 Kgs. Lyngby, Denmark
Tel: +45-7022-0103
E-mail: tts@taegutec.dk

Finland

Knorrung OY AB

Mestarintie 4 FI-01730 Vantaa, Finland
Tel: +358-9-560-41
E-mail: knorrung@knorrung.fi

France

Ingersoll France S.A.R.L

22 Rue Albert Einstein -BAT.3
F-77420 Champs Sur Marne, France
Tel: +33 (0)1-64-68-45-36
E-mail: info@ingersoll-ipc.fr

Germany

Ingersoll Werkzeuge GmbH

Kalteiche Ring 21-25, D-35708
Haiger, Germany
Tel: +49-2773-742 146
E-mail: info@Ingersoll-IMC.de

Greece

Technotools Monoprosopi I.K.E

25th Martiou & Thrakis 15, 15235 Vrilissia,
Athens, Greece
Tel: +30-2-10-832-0752
E-mail: Giorgos@technotools.gr

Hungary

TaeguTec Hungary KFT.

1142 Budapest, Kassai u.151.
Tel: +36-1-273-29-55
E-mail: info@taegutec.hu

India

TaeguTec India Pvt. Ltd.

No.120, Bommasandra Industrial Area,
Phase IV, Bangalore-560 099, India
Tel: +91-80-4901-3000
E-mail: sales@taegutec-india.com

Indonesia

PT. TaeguTec Indonesia

Easton Commercial Center
Jl. Gunung Panderman Blok B no. 12
Cikarang Selatan-Bekasi 17550, Indonesia
Tel: +62-21-29093176/78
E-mail: sales@taegutec.co.id

Ireland

Hardmetal Machine Tools Ireland Ltd.

Dargan House, Duncairn Terrace,
Bray Co. Wicklow, Ireland
Tel: +353-1-286-2466
E-mail: sales@hardmetal.ie

Italy

Ingersoll TaeguTec Italia S.R.L.

Via Monte grappa N.78, 20020 Arese (MI), Italy
Tel: +39 02.99.76.6700
E-mail: taegutec@taegutec.it

Japan

TaeguTec Japan Ltd.

Senri Asahi Hankyu Bldg. 20F
1-5-3 Shinsenri-Higashimachi
Toyonaka-shi Osaka 560-0082, Japan
Tel: +81-6-6835-7731
E-mail: taegutec@taegutec.co.jp

Lithuania

UAB TTMT

Panerių Str. 5 LT-48337 Kaunas, Lithuania
Tel: +370-37-328487
E-mail: giedre@ttmt.lt

Malaysia

TaeguTec Tooling Systems

Malaysia Sdn. Bhd

No.23-1&2, Jalan Anggerik Vanilla
BF 31/BF Kota Kemuning, Seksyen 31
40460 Shah Alam Selangor D.E., Malaysia
Tel: +603-5131-7514
E-mail: info@taegutec.com.my

The Netherlands

TCE Tools

Kennedylaan 14, 5466 AA, Veghel,
The Netherlands
Tel: +31 (413) 38 83 10
E-mail: info@tce-tools.nl

New Zealand

TaeguTec Pacific Ltd.

1/501 Mt. Wellington Highway
Sylvia Park, Auckland, New Zealand 1060
Tel: +64-0800-808-477
E-mail: sales@iscar.co.nz

Norway

Svea Service AS

Graaterudveien 20 No-3036 Drammen,
Norway
Tel: +47-32-277-750
E-mail: per.martin.bakken@svea.no

Pakistan

Dynamic Tooling Services

Office No. 304, 3rd Floor, Azeem
Mansion, Fazal-ul-Haque Road,
Blue Area, Islamabad-44000, Pakistan
Tel: +92-51-2150382/383
E-mail: info@dts.com.pk

Peru

Trade Tools Cia. S.A.C.

Av. Guillermo Dansey No 774
Urb. Lima Industrial, Lima Peru 4000.
Tel: +51-01-433-6999
E-mail: purchases@tradetoolscia.com.pe

Philippines

Colt Commercial Inc.

No.52B Baleate Drive, Brgy Mariana
NCR, 2nd District Quezon City
Philippines 1112
Tel: +63-2-8244-9757
E-mail: cyrus@colt.com.ph

Poland

TaeguTec Polska Sp. z o.o.

Ul.Nenckiego 136
52-223 Wrocław, Poland
Tel: +48 71 785 40 85
E-mail: sales@taegutec.pl

Portugal

Hexatool, S.A.

Rua Casal Galego, N°70A
2430-084 Casal Galego
Marinha Grande, Portugal
Tel: +351-244-550424/5
E-mail: hexatool@hexatool.com

Romania

SC TaeguTec Tools SRL

Splaiul Unirii, nr. 4, Bl. B3, 5th Floor,
Office 5.1, District 4., Bucharest,
Romania, 040031
Tel: +4021 210 3108
E-mail: marian.luca@taegutec.ro

Russia

TaeguTec Russia

123290, Russia, Moscow,
2nd Magistralnaya str, 8A, building 5
Tel: +7-495-221-7617
E-mail: sales@taegutec.ru

Serbia

Intehna Beo D.O.O.

Autoput 22, 11080 Zemun, Serbia
Tel: +381-11-3149-092
E-mail: info@intehna.rs

Singapore

TT Tooling Systems

BK502, #03-823, Jurong West Avenue 1,
Singapore 640502
Tel: +65-6-4254918
E-mail: kltan@sinotool.com.sg

Slovakia

TaeguTec Slovakia, s.r.o.

Bytčická 2/44 010 01 Žilina Slovak
Republic
Tel: +421 41 7000056
E-mail: info@taegutec.sk

Slovenia

Intehna D.O.O.

Špruha 40, Si-1236, Trzin, Slovenia
Tel: +386-1-580-9260
E-mail: info@intehna.si

South Africa

TaeguTec South Africa (Pty) Ltd.

Block F, Clearwater Office Park,
Corner of Atlas and Park Roads,
Parkhaven, Boksburg 1459, South Africa
Tel: +2711-362-1500
E-mail: info@taegutec.co.za

Spain

TaeguTec Spain S.L.U

Miquel Servet, 35 P.I.Bufalvent
08243 Manresa (Barcelona), Spain
Tel: +34-93-878-7309/7310
E-mail: info@taegutec.es

Sweden

SMV Verktyg AB

Parkgatan 6
SE-333 31 Smalandsstenar, Sweden
Tel: +46-371-343-40
E-mail: verktyg@smv.se

Taiwan

Qunling International Trading Co.,Ltd.

RM B, 7F, No. 801 of Zhongzheng Road,
Zhonghe District, New Taipei City 23552,
Taiwan
Tel: +886-2-2223-0851
E-mail: qunling.service@qunling.url.tw

Thailand

TaeguTec(Thailand) Co.,Ltd.

6/177 M.7 Srinakarin Rd.,
T.Bangmuang, A.Muangsamutprakarn,
Samutprakarn 10270, Thailand
Tel: +66-2-759-9300
E-mail: info@taegutecthai.co.th

Turkey

TaeguTec Kesici Takimler A.S.

TOSB Otomotiv Yan Sanayi Ihtisas
Organize Sanayi Bolgesi
1.Cad. 15.Sokak No:9 41420 Şekerpınar
Çayırova/KOCAELI, Türkiye
Tel: +90-850-201-6900
E-mail: info@taegutec.com.tr

Ukraine

TaeguTec Ukraine LLC

40-b, Lesya Ukrainka avenue, Dnipro,
Ukraine, 49006
Tel: +38-056-790-84-09
E-mail: td@taegutec.com.ua

United Arab Emirates

Varycarb Tools Trading LLC

Office BC-53
European Business Centre, DIP-1
Dubai, U.A.E
Tel: +971561610359
E-mail: santosh.gawade@varycarb.com

United Kingdom

TaeguTec UK Ltd.

Waterside, Grange Park, Wetherby,
Leeds, LS22 5NB, United Kingdom
Tel: +44-1937-589-828
E-mail: info@taegutec.co.uk

U.S.A.

Ingersoll Cutting Tools

845 S Lyford Road Rockford,
IL 61108-2749, U.S.A.
Tel: +1-815-387-6600
E-mail: info@ingersoll-imc.com

Vietnam

TaeguTec Vietnam Limited Liability

3rd Floor, Intan Building, 97 Nguyen
Van Troi Street, Ward 12, Phu Nhuan Dist,
HCMC, Vietnam.
Tel: +84-28-3999-1835
E-mail: info@taegutec.vn



ADVANCE*e***CUTTING**
TaeguTec



6 2 6 6 7 5 0

- Cat. no.: 6266750
- English version: CT 02/2024
- ©TaeguTec LTD.