

14D-F45XN-06

Face mills

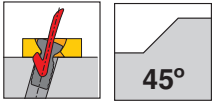
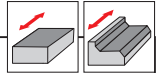
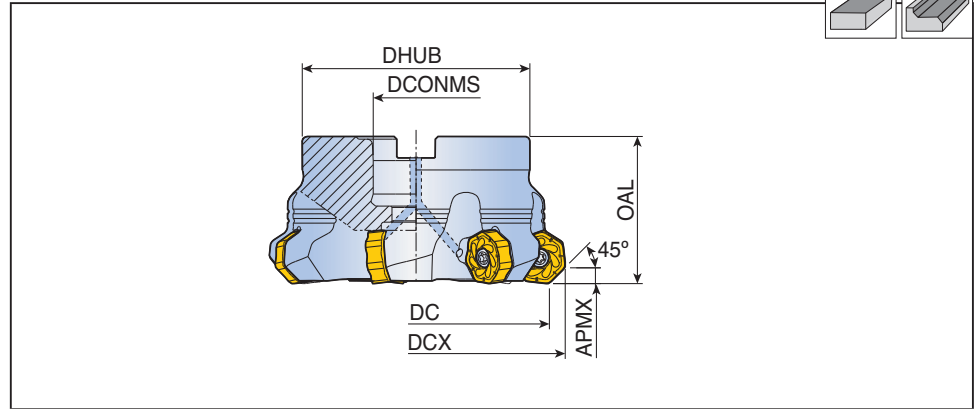

Designation		Dimension (mm)						Coolant hole	Arbor style	Kg	Mounting bolt	Insert
		DC	DCX	DCONMS	DHUB	OAL	APMX					
14D-F45XN550-22R-06	5	50	59.1	22	45	40	3.5	●	A	0.4	LH M10x25	XNM(H)U 0605... E281
563-22R-06	5	63	72.1	22	47	50	3.5	●	A	0.8	SH M10x25	
763-22R-06	7	63	72.1	22	47	50	3.5	●	A	0.8	SH M10x25	
680-27R-06	6	80	89.1	27	70	50	3.5	●	A	1.4	SH M12x35	
980-27R-06	9	80	89.1	27	70	50	3.5	●	A	1.4	SH M12x35	
7100-32R-06	7	100	109.1	32	85	50	3.5	●	A	2.1	SH M16x35	
11100-32R-06	11	100	109.1	32	85	50	3.5	●	A	2.1	SH M16x35	
10125-40R-06	10	125	134.1	40	85	63	3.5	●	A	3.6	SH M20x40	
14125-40R-06	14	125	134.1	40	85	63	3.5	●	A	3.6	SH M20x40	
12160-40R-06	12	160	169.1	40	110	63	3.5	x	C	4.7	-	
16160-40R-06	16	160	169.1	40	110	63	3.5	x	C	4.9	-	
18160-40R-06	18	160	169.1	40	110	63	3.5	x	C	5.0	-	
14D-F45XN763-25.4R-06	7	63	72.1	25.4	47	50	3.5	●	A	0.8	SH M12x30	
980-25.4R-06	9	80	89.1	25.4	70	50	3.5	●	A	1.4	SH M12x35	
11100-31.75R-06	11	100	109.1	31.75	80	50	3.5	●	A	1.9	LH M16x35	
14125-38.1R-06	14	125	134.1	38.1	80	63	3.5	x	B	3.9	-	
16160-50.8R-06	16	160	169.1	50.8	100	63	3.5	x	B	5.0	-	

• Mounting bolt with coolant through hole is available on request (ordering example: SH M10x1.5x30-C)

Spare parts

Designation	Screw	Wrench			
14D-F45XN-06	TS 40B100I	T-T15			

